

## Introduction

This manual provides information needed to operate and understand the vehicle and its components. More detailed information is contained in the *Owner's Warranty Information for North America* booklet, and in the vehicle's workshop and maintenance manuals.

Custom-built Sterling vehicles are equipped with various chassis and cab components. Not all of the information contained in this manual applies to every vehicle. For details about components in your vehicle, refer to the chassis specification pages included in all new vehicles and to the vehicle specification decal, located inside the vehicle.

For your reference, keep this manual in the vehicle at all times.

**IMPORTANT:** Descriptions and specifications in this manual were in effect at the time of printing. Sterling Truck Corporation reserves the right to discontinue models and to change specifications or design at any time without notice and without incurring obligation. Descriptions and specifications contained in this publication provide no warranty, expressed or implied, and are subject to revisions and editions without notice.

## Environmental Concerns and Recommendations

Whenever you see instructions in this manual to discard materials, you should first attempt to reclaim and recycle them. To preserve our environment, follow appropriate environmental rules and regulations when disposing of materials.

## Event Data Recorder

This vehicle is equipped with one or more devices that record specific vehicle data. The type and amount of data recorded varies depending on how the vehicle is equipped (such as the brand of engine, if an air bag is installed, or if the vehicle features a collision avoidance system, etc.).

## Customer Assistance Center

Having trouble finding service? Call the Customer Assistance Center at 1-800-STL-HELP or 1-800-785-4357. Call night or day, weekdays or weekends, for dealer referral, vehicle information, breakdown

coordination, or Fleetpack assistance. Our people are knowledgeable, professional, and committed to following through to help you keep your truck moving.

## Reporting Safety Defects

If you believe that your vehicle has a defect which could cause a crash or could cause injury or death, you should immediately inform the National Highway Traffic Safety Administration (NHTSA) in addition to notifying Sterling Truck Corporation.

If the NHTSA receives similar complaints, it may open an investigation, and if it finds that a safety defect exists in a group of vehicles, it may order a recall and remedy campaign. However, NHTSA cannot become involved in individual problems between you, your dealer, or Sterling Truck Corporation.

To contact NHTSA, you may call the Vehicle Safety Hotline toll-free at 1-888-327-4236 (TTY: 1-800-424-9153); go to [www.safercar.gov](http://www.safercar.gov); or write to: Administrator, NHTSA, 1200 New Jersey Avenue, SE, Washington, DC 20590. You can also obtain other information about motor vehicle safety from [www.safercar.gov](http://www.safercar.gov).

Canadian customers who wish to report a safety-related defect to Transport Canada, Defect Investigations and Recalls, may telephone the toll-free hotline 1-800-333-0510, or contact Transport Canada by mail at: Transport Canada, ASFAD, Place de Ville Tower C, 330 Sparks Street, Ottawa, Ontario, Canada K1A 0N5.

For additional road safety information, please visit the Road Safety website at: [www.tc.gc.ca/roadsafety/menu.htm](http://www.tc.gc.ca/roadsafety/menu.htm).

# Foreword

---

© 1998–2009 Daimler Trucks North America LLC. All rights reserved. Daimler Trucks North America LLC is a Daimler company.

No part of this publication, in whole or part, may be translated, reproduced, stored in a retrieval system, or transmitted in any form by any means, electronic, mechanical, photocopying, recording, or otherwise, without the prior written permission of Daimler Trucks North America LLC. For additional information, please contact Daimler Trucks North America LLC, Service Systems and Documentation, P.O. Box 3849, Portland, OR 97208–3849 U.S.A. or refer to [www.Daimler-TrucksNorthAmerica.com](http://www.Daimler-TrucksNorthAmerica.com) and [www.SterlingTrucks.com](http://www.SterlingTrucks.com).

# Contents

---

Chapter		Page
	Introduction, Environmental Concerns and Recommendations, Event Data Recorder, Customer Assistance Center, Reporting Safety Defects .....	Foreword
1	Vehicle Identification .....	1.1
2	Instruments and Controls Identification .....	2.1
3	Vehicle Access .....	3.1
4	Heater and Air Conditioner .....	4.1
5	Seats and Seat Belts .....	5.1
6	Steering and Brake Systems .....	6.1
7	Engines and Clutches .....	7.1
8	Transmissions .....	8.1
9	Rear Axles .....	9.1
10	Fifth Wheels .....	10.1
11	Pretrip and Post-Trip Inspections and Maintenance .....	11.1
12	Cab Appearance .....	12.1
13	In an Emergency .....	13.1
	Index .....	I.1

# 1

## Vehicle Identification

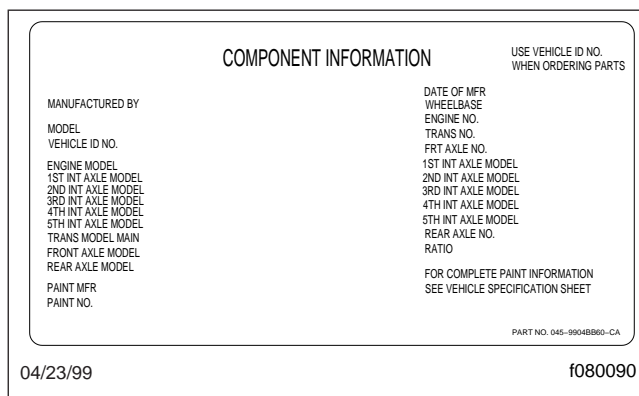
---

Vehicle Specification Decal .....	1.1
Federal Motor Vehicle Safety Standard (FMVSS) Labels .....	1.1
Canadian Motor Vehicle Safety Standard (CMVSS) Labels .....	1.2
Tire and Rim Labels .....	1.2
EPA Emission Control .....	1.2

# Vehicle Identification

## Vehicle Specification Decal

The vehicle specification decal lists the vehicle model, identification number, and major component models. It also recaps the major assemblies and installations shown on the chassis specification sheet. The specification decal is inside the rear cover of the *Owner's Warranty Information for North America* booklet. An illustration of the decal is shown in **Fig. 1.1**.



**Fig. 1.1, Vehicle Specification Decal, Canadian-Built Vehicle Shown**

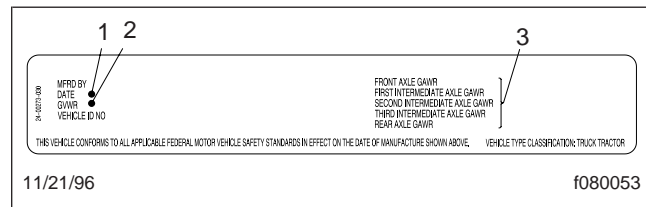
NOTE: Labels shown in this chapter are examples only. Actual specifications may vary from vehicle to vehicle.

## Federal Motor Vehicle Safety Standard (FMVSS) Labels

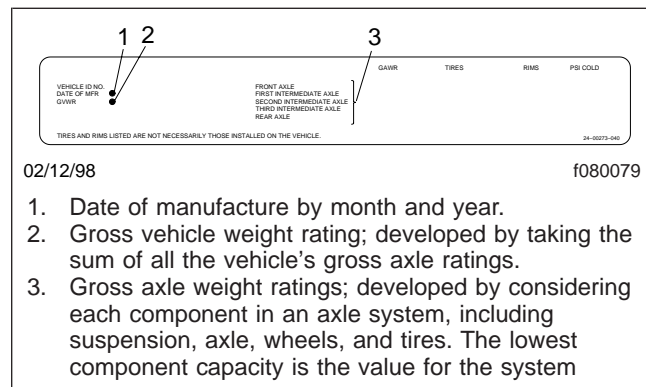
NOTE: Due to the variety of FMVSS certification requirements, not all of the labels shown will apply to your vehicle.

Tractors with or without fifth wheels purchased in the U.S. are certified by means of a certification label (**Fig. 1.2**) and the tire and rim labels (**Fig. 1.3**). These labels are attached to the driver's side rear door post, as shown in **Fig. 1.4**.

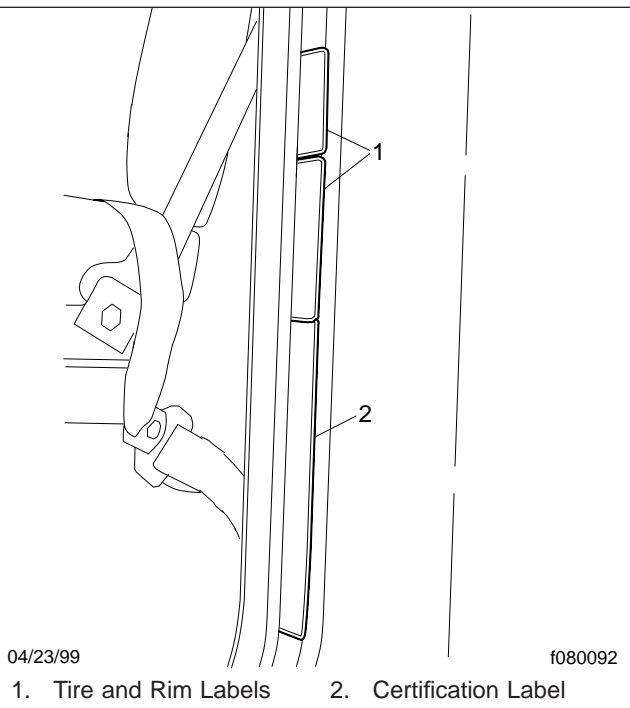
If purchased for service in the U.S., trucks built without a cargo body have a certification label (**Fig. 1.5**) attached to the driver's side rear door post. See **Fig. 1.4**. In addition, after completion of the vehicle, a certification label similar to that shown in **Fig. 1.2** must be attached by the final-stage manufacturer. This label will be located on the driver's side rear door post and certifies that the vehicle conforms to



**Fig. 1.2, Certification Label, U.S.**



**Fig. 1.3, Tire and Rim Label**



**Fig. 1.4, Labels Location (left-hand drive shown)**



# Vehicle Identification







EXHAUST AFTERTREATMENT SYSTEM INFORMATION					
INDICATOR LAMP(S)	 (Solid) Level 1	 (Flashing) Level 2	 (Flashing) CHECK Level 3	 (Flashing) CHECK STOP Level 4	 WARNING 
Indicator Lamp Message(s)	Filter Regeneration Recommended	Filter Regeneration Necessary	Parked Regeneration Required – Engine Derate	Parked Regeneration Required – Engine Shut Down	HEST (High Exhaust System Temperature)
Diesel Particulate Filter Condition	Filter is reaching capacity.	Filter is now reaching maximum capacity.	Filter has reached maximum capacity.	Filter has exceeded maximum capacity.	<b>Flashing</b> A regeneration is in progress.
Required Action	Bring vehicle to highway speeds to allow for an Automatic Regeneration or perform a Parked Regeneration.	To avoid engine derate bring vehicle to highway speeds to allow for an Automatic Regeneration or perform a Parked Regeneration as soon as possible.	Vehicle must be parked and a Parked Regeneration must be performed – engine will begin derate.	Vehicle must be parked and a Parked Regeneration or Service Regeneration must be performed. Check engine operator's manual for details –engine will shut down.	<b>Solid</b> Exhaust Components and exhaust gas are operating at high temperature. When stationary, keep away from people and flammable materials, vapors, or structures.
For a driver performed Parked Regeneration, vehicle must be equipped with a dash mounted Regeneration Switch.					
<b>See Engine Operator's Manual for complete Regeneration Instructions.</b>					24-01583-0008

Fig. 1.8, Sunvisor Warning Label

# 2

## Instruments and Controls Identification

---

Controls .....	2.1
Instruments .....	2.10
Warning and Indicator Lights .....	2.13
Instrumentation Control Unit 4 (ICU4) .....	2.16
Instrumentation Control Unit 3 (ICU3) .....	2.19
NGI Instrument Cluster .....	2.23
Eaton Vorad .....	2.25
Roll Stability Control .....	2.30



# Instruments and Controls Identification

## Controls

**Figure 2.1** represents a typical dash equipped with all of the standard and many of the optional instruments and accessories.

The instrumentation control unit (ICU) houses most warning and indicator lights, most gauges, and a message display screen. Warning messages and diagnostic fault codes will appear in the message display screen. For more information, see the appropriate heading in this chapter, depending on the type of ICU installed in the vehicle.

## Ignition Switch

The ignition switch may have three or four positions: OFF, ACCESSORY, ON, and START (if equipped). See **Fig. 2.1**.

In the OFF position, the key slot is vertical; the key can be inserted and removed only in this position.

In the ACCESSORY position, the key is turned counterclockwise.

In the ON position, the key is turned clockwise.

In the START position (if equipped), the engine will crank until you release the key. The key will return to the ON position.

The engine start button (if equipped), is used to start the engine after the key is in the ON position. See **Fig. 2.2**. Turn the key to the ON position, then push the engine start button.

## Power Windows

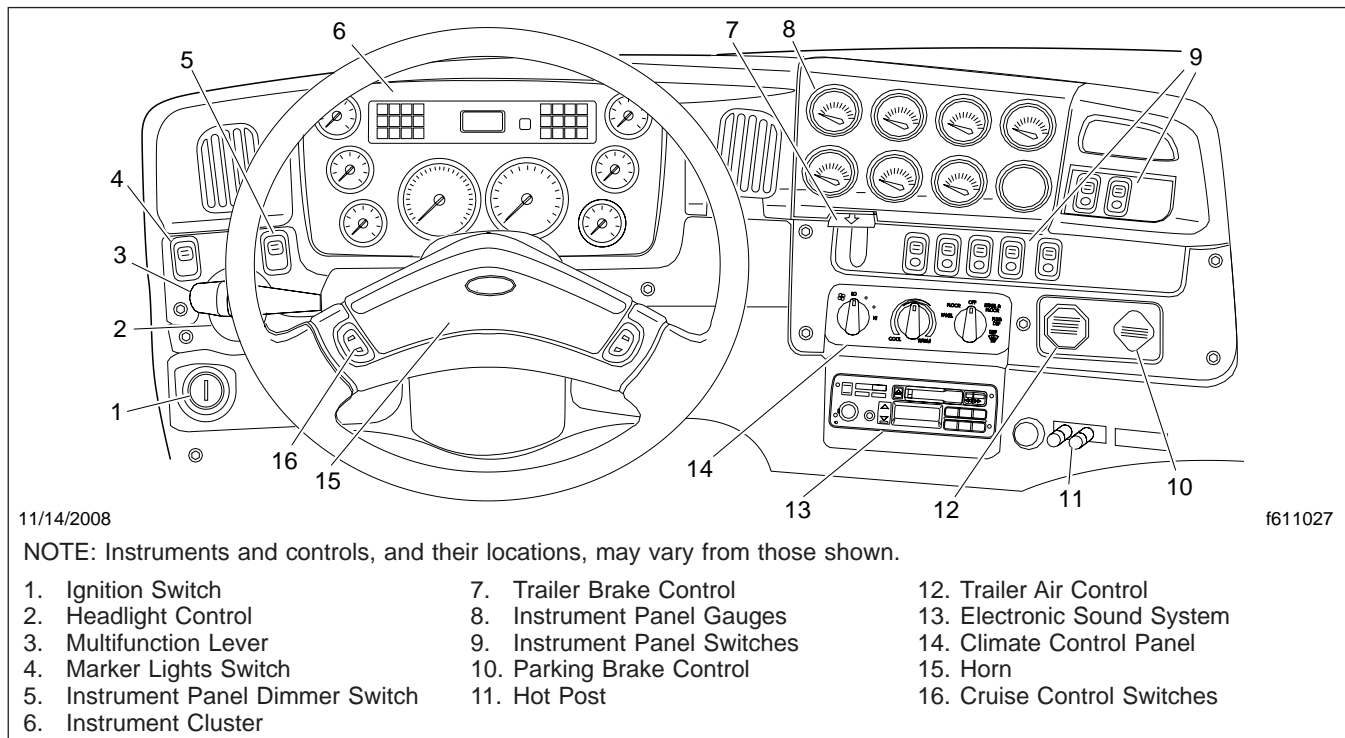
The driver's door has the master controls that operate both windows. See **Fig. 2.3**.

- Press the top of the switch to close the window.
- Press the bottom of the switch to open the window.

## Power Locks

Press the U to unlock all doors. Press the L to lock all doors. See **Fig. 2.4**.

**IMPORTANT:** Remove the ignition key and lock all doors when leaving your vehicle unattended.



**Fig. 2.1, Instrument and Control Panel Layout**

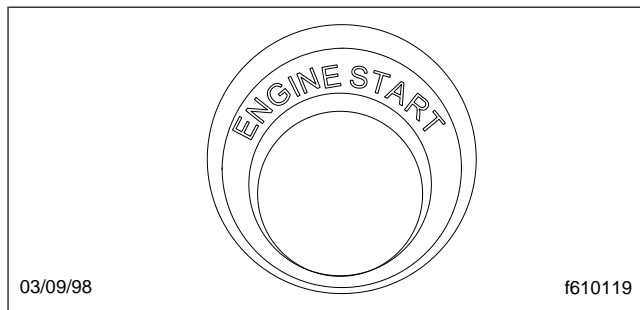


Fig. 2.2, Engine Start Button

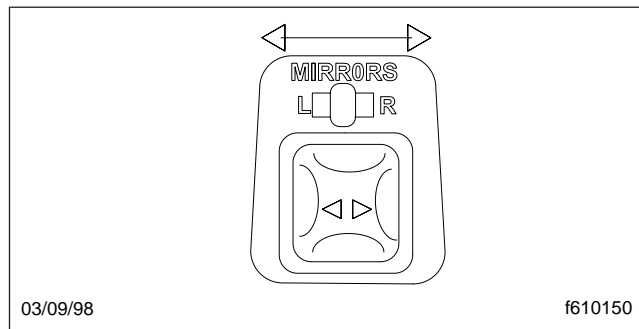


Fig. 2.5, Power Mirror Control

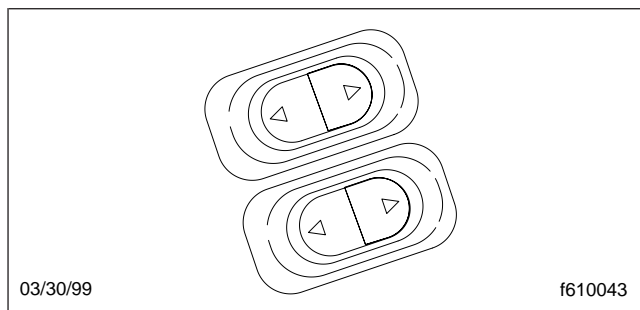


Fig. 2.3, Power Window Controls

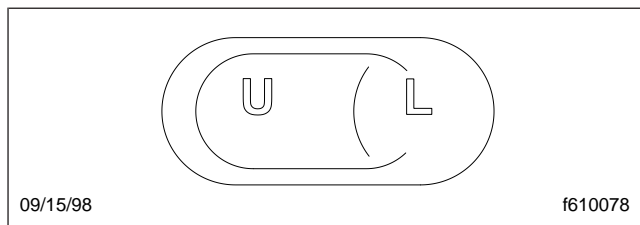


Fig. 2.4, Power Lock Control

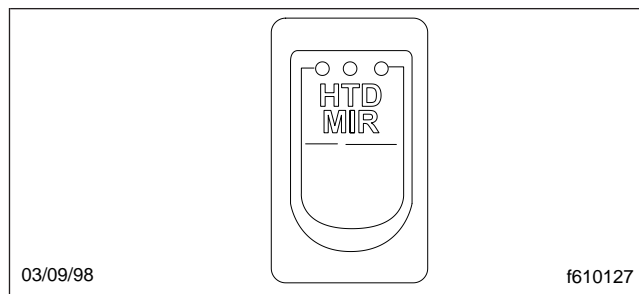


Fig. 2.6, Heated Mirror Switch, Optional

## Mirror Controls

### Power Mirrors

The remote control mirrors are controlled by one switch located on the driver door panel by the door handle. Use the switch to select which mirror (left or right) is adjusted and to control the left/right movement of the large mirrors. See [Fig. 2.5](#).

### Lighted Mirrors, Optional

These lights act like marker lights. The mirror lights will come on when the marker lights are turned on.

## Heated Mirrors, Optional

Press the top part of the heated mirror switch to heat the mirrors. See [Fig. 2.6](#). An indicator light will illuminate above the switch when it is activated.

## Aero Side-View Mirrors, Optional

The heated, dual-axis mirrors are controlled by two switches located on the driver door panel near the door handle.

- The L-R control on each switch selects which mirror (left or right) is adjusted.
- The upper control controls the large flat mirror.
- The lower control controls the convex mirror.

## Instrument Panel Dimmer Switch

The instrument panel dimmer switch is located to the left of the instrument cluster. The instrument panel lights can be brightened or dimmed by moving the switch up or down. The dome light can be turned ON by moving the switch all the way up.

# Instruments and Controls Identification

## Headlight/Parking Light Switch

Turn the control clockwise to the first notch to turn ON the parking lights. Turn the control completely to the right to turn ON the headlights.

## Daytime-Running Lights



**The daytime-running-light system does not illuminate the taillights or parking lights. Turn on the headlight switch at dusk. Failure to do so may result in a collision.**

Vehicles equipped with daytime-running lights (DRL) have the headlights illuminated at a reduced intensity during daytime driving. These lights are not to be used in place of normal headlights needed for reduced visibility and nighttime driving conditions.

The lights are automatically turned on when:

- the vehicle is started;
- the parking brake is released;
- the headlight system is in the OFF position.

When daytime-running lights are actuated (the headlight switch is OFF) only the headlights are illuminated, and at lower intensity. Marker lights, taillights, and trailer lights are not illuminated.

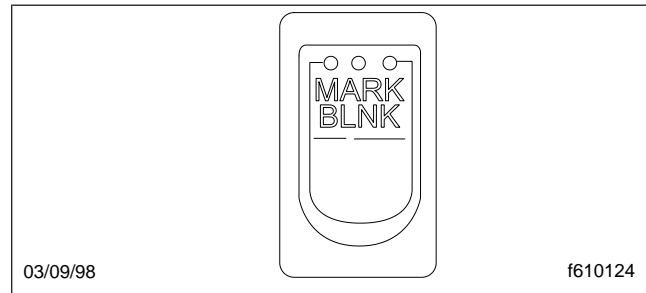
**NOTE:** A warning light is illuminated to alert you that you are driving with reduced intensity headlights.

## Clearance Lights/Blink Switch

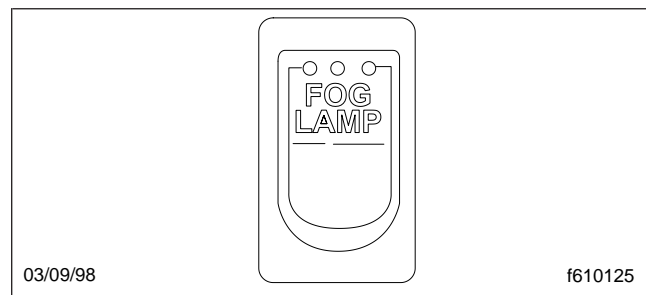
To turn on the clearance lights, flip the switch up from the OFF position to the ON position. To blink the clearance lights, flip the switch up past the ON position. The switch will return to the ON position. See [Fig. 2.7](#).

## Fog Lights Switch

The fog lights may be used for hazardous or low visibility driving conditions. Turn the low-beam headlights on. Press the top part of the switch to turn the fog lights ON. See [Fig. 2.8](#).



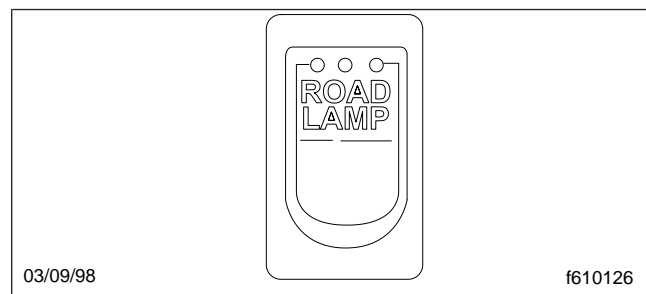
**Fig. 2.7, Clearance Lights and Blink Switch**



**Fig. 2.8, Fog Light Switch, Optional**

## Road Lights Switch

The road lights may be used for hazardous or low visibility driving conditions. Turn the low-beam headlights on. Press the top part of the switch to turn the road lights ON. See [Fig. 2.9](#).



**Fig. 2.9, Road Light Switch, Optional**

## Idle-Speed Control, Optional

On electronically controlled engines, adjust the low idle speed in 25 rpm increments by pressing the top part of the engine idle switch.

When the key is turned OFF, the new low engine idle speed is saved. Low idle specifications are provided in the engine operation manual for your vehicle.

# Instruments and Controls Identification

## Hot Post, Optional

A hot post is provided as a source of power within the cab to operate 12-volt electrical accessories. A power and ground jack are included in the hot post. See [Fig. 2.10](#).

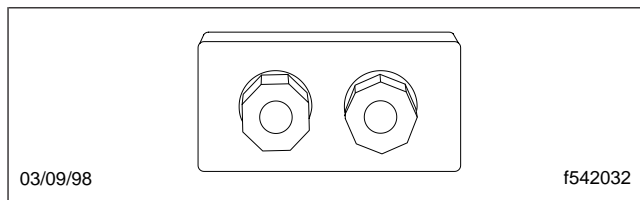


Fig. 2.10, Hot Post, Optional

## Heater/Air-Conditioner Controls

See [Chapter 4](#) for detailed operating instructions of the heater/air conditioner.

## Engine Brake Controls

### Jacobs or Cummins C-Brake Switch, Optional

The engine brake is controlled by a dash-mounted paddle switch that controls the degree of engine braking. See [Fig. 2.11](#). See [Chapter 7](#) under the heading "Engine Braking System, Optional" for additional information.

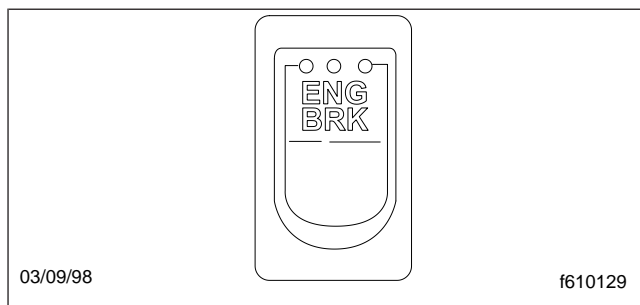


Fig. 2.11, Engine Brake Switch, Optional

### Min/Max Switch, Optional

This switch increases or decreases the amount of braking effort the Jacobs or Cummins C-Brake will apply. See [Chapter 7](#) under the heading "Engine Braking System, Optional" for additional information.

## Exhaust Brake, Optional

The exhaust brake restricts the flow of exhaust gases, which retards the engine. See [Chapter 7](#) under the heading "Engine Braking System, Optional" for additional information. See [Fig. 2.12](#).

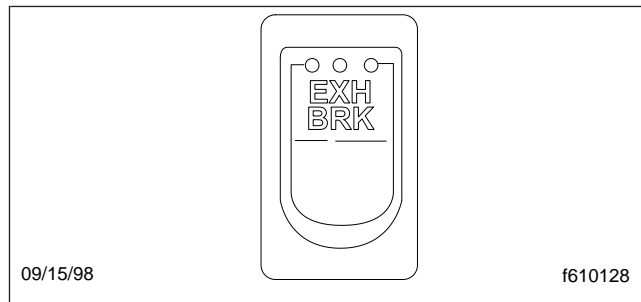


Fig. 2.12, Exhaust Brake Switch, Optional

## Axle Controls

### Interaxle Differential Lockout Control Valve Switch

Differential lockout, standard on all dual-drive vehicles, is driver-actuated by means of a control switch mounted on the control panel. See [Fig. 2.13](#). A red indicator light comes on whenever the interaxle differential is locked out (switch is in the lock position; no differential action between the drive axles).

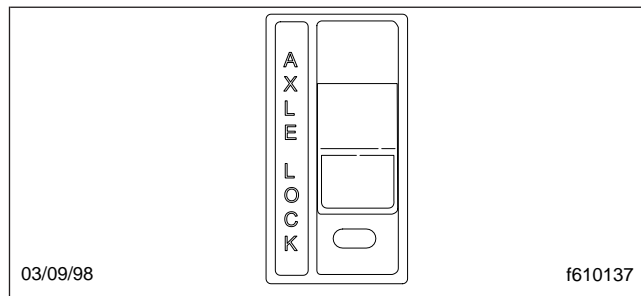


Fig. 2.13, Axle Lock Switch

### Wheel Lock Switch

A controlled-traction-differential feature is included or available as an option on some rear axles. A switch engages and disengages the controlled-traction feature. See [Fig. 2.14](#). See [Chapter 9](#) for complete operating instructions.

# Instruments and Controls Identification

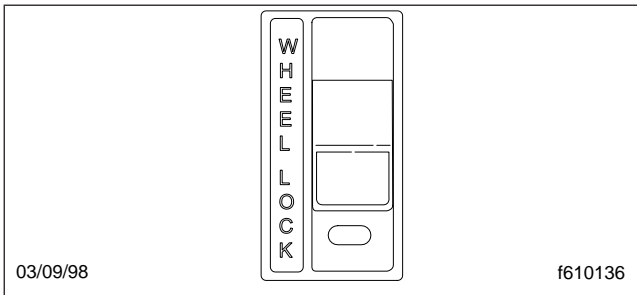


Fig. 2.14, Wheel Lock Switch

## 2-Speed Axle, Optional

The 2-speed axle switch allows you to put the axle in HI or LO range. This feature is only available with automatic transmissions. See Fig. 2.15.

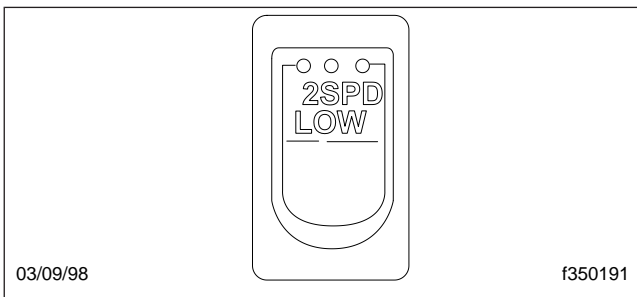


Fig. 2.15, 2-Speed Axle Switch, Optional

## Fifth Wheel Air Slide Control Valve Switch



**CAUTION**

Do not activate the fifth wheel slide control valve while the vehicle is in motion. To do so could cause damage to the fifth wheel member, the kingpin, the cab or trailer, and ultimately to the drivetrain.

The fifth wheel air slide valve permits repositioning of the sliding fifth wheel from inside the cab. Moving the air slide control switch to the center position deactivates the control valve and locks the fifth wheel to the baseplate. Moving the switch up from the center position activates the control valve and unlocks the fifth wheel slide mechanism, allowing changes to the total length of the tractor-trailer and changes to axle loads to comply with varying state or provincial laws. See Fig. 2.16. A red indicator light, if equipped, is

illuminated whenever the fifth wheel slide is unlocked.

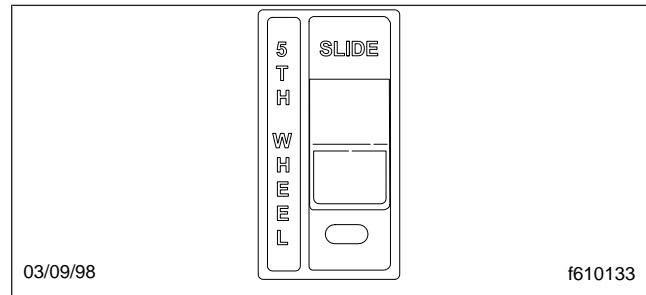


Fig. 2.16, Fifth Wheel Air Slide Switch

## Parking Brake Valve

The yellow diamond-shaped knob operates the parking brake valve. See Fig. 2.17. Pull out the knob to apply both the tractor and the trailer spring brakes. Push in the knob to release the tractor spring brakes. Before the spring brakes can be released, the air pressure in either air brake system must be at least 65 psi (447 kPa).

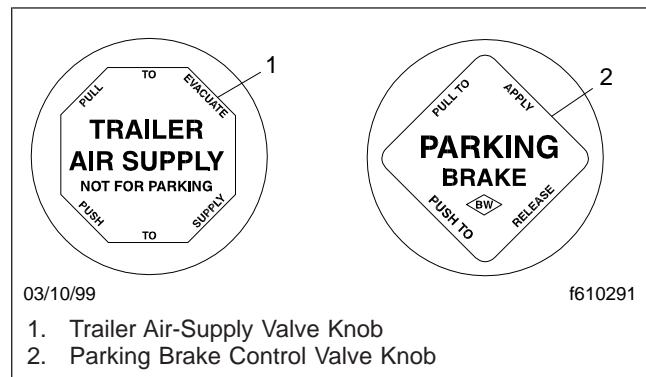


Fig. 2.17, Brake Valves

See Chapter 6 under the heading "Brake System" for instructions regarding use of the trailer air-supply valve and parking brake valve.

## Trailer Air-Supply Valve

The red octagonal-shaped knob operates the trailer air-supply valve. See Fig. 2.17. After the vehicle air hoses are connected to a trailer, and the pressure in the air system is at least 65 psi (447 kPa), push in the trailer air-supply valve knob (it should stay in) to charge the trailer air supply system, and release the trailer spring brakes. Before disconnecting a trailer,

# Instruments and Controls Identification

or when operating a vehicle without a trailer, pull out the trailer air-supply valve knob.

See [Chapter 6](#) under the heading "Brake System" for instructions regarding use of the trailer air-supply valve and parking brake valve.

## Air-Suspension Switch, Optional

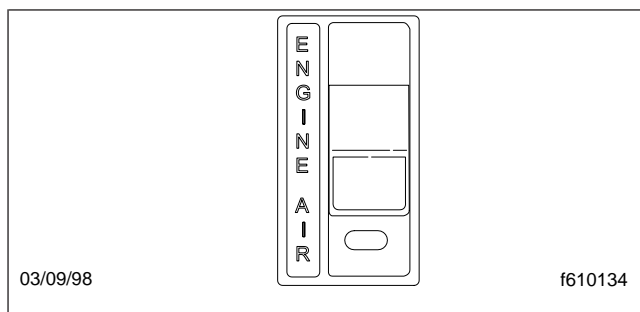


**Never exhaust air from the suspension while driving. If the air is exhausted, the suspension will not absorb road shocks and could be damaged.**

The air-suspension dump valve allows the air in the suspension to be quickly exhausted, lowering the rear of the vehicle. This makes it easier to connect to or disconnect from a trailer. A control-valve switch exhausts and fills the air suspension. To exhaust air from the suspension, move the switch up to the exhaust position.

## Engine-Air Switch, Optional

When there is a risk of airborne snow plugging the air cleaner, the engine-air switch closes the fresh-air-intake openings in both sides of the hood, and draws air from the engine compartment. See [Fig. 2.18](#).



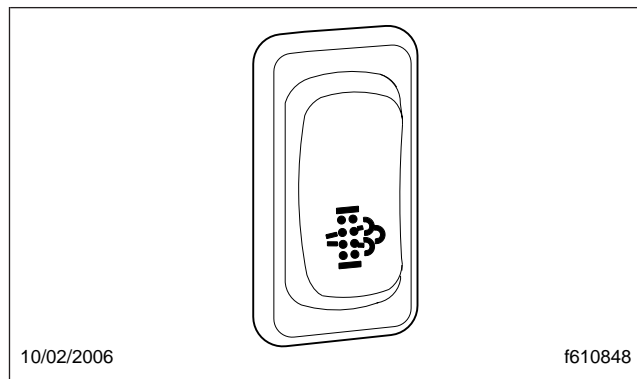
**Fig. 2.18, Engine-Air Switch, Optional**

The system is activated by moving the switch from the NORMAL position to the UNDERHOOD position.

## Aftertreatment System (ATS) Request/Inhibit Regen Switch

A parked regen of the ATS can be initiated with the request/inhibit regen switch. It may also be used to inhibit the vehicle from performing an automatic regen. See [Fig. 2.19](#).

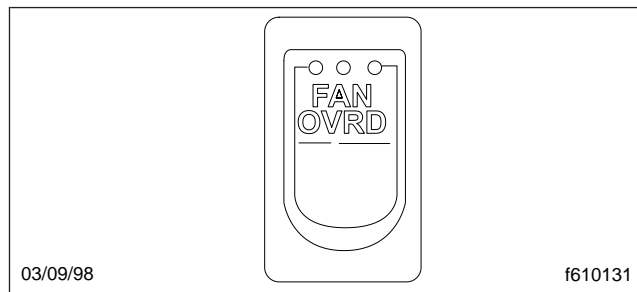
The style and function of switch will vary with the engine make and model. See the engine operation manual for details.



**Fig. 2.19, Request/Inhibit Regen Switch**

## Fan Override Switch

The fan override allows the cooling fan cycle to be overridden so that the fan will run at all times. This feature can only be activated when the engine is running and the parking brake is ON. See [Fig. 2.20](#).



**Fig. 2.20, Cooling Fan Override Switch**

## Tilt/Telescoping Steering Wheel

To tilt the steering wheel, push the control down while tilting the column to the desired position by gripping the steering wheel at a location closest to your body. Release the lever to lock the column in place. See [Fig. 2.21](#).

To telescope the steering wheel, pull the control up while pulling the steering wheel closer or pushing the steering wheel further away. Release the lever to lock the column in place.

# Instruments and Controls Identification

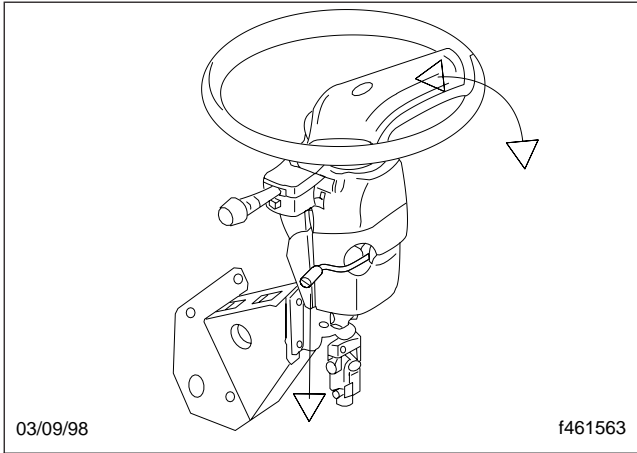


Fig. 2.21, Tilt/Telescoping Steering Wheel

## Windshield Wiper/Washer Controls

### **WARNING**

Do not use the windshield washer in freezing weather without first warming the windshield using the defroster. Otherwise the washer solution may freeze on the windshield and obscure your vision. This could cause an accident, possibly resulting in personal injury or property damage.

### **CAUTION**

Do not operate the windshield washer when the fluid reservoir is empty. Operating the windshield washer system when the reservoir is empty could damage the system.

Place the ignition key in either the ON or Accessory position.

Turn the knob on the end of the turn-signal control toward the front of the vehicle. See Fig. 2.22. The control can be turned to LO, HI, or to an interval speed. Rotate the control to adjust the interval and speed.

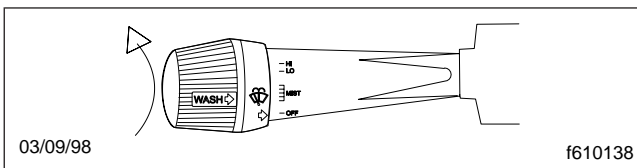


Fig. 2.22, Windshield Wiper Controls

Push in the wiper/washer control knob to activate the windshield washers. Fluid will continue to spray as long as the control is pushed in. Upon release of the control, the wipers will cycle an additional two or three times.

## Turn Signals

The turn-signal controls are located in the multifunction lever. Push the control down to activate the left turn signal. Push the control up to activate the right turn signal. If equipped with a self-canceling turn signal control, the control will cancel after the turn has been completed.

## Headlight High/Low Beam Control

To change the headlights from low to high beam, push the turn-signal control away from you. An indicator light will illuminate on the instrument cluster when the high beams are activated.

To activate the low beams, pull the turn signal control toward you until it clicks into position.

## Headlight High/Low Beam Control (Signal-Stat)

To change the headlights from low to high beam, pull the turn signal lever toward you. An indicator light will illuminate on the instrument cluster when the high beams are activated.

## Flash-to-Pass

To momentarily flash the high beams with the headlights OFF, slightly pull the turn signal lever toward the steering wheel, then release it.

To momentarily flash the high beams with the headlights on, pull the turn signal lever toward the steering wheel through the high beam detent, then release it.

## Cruise Control, Optional

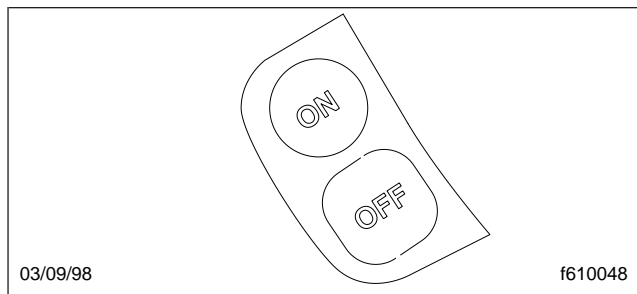
### **WARNING**

Do not use the cruise control system when driving conditions do not permit maintaining a constant speed, such as in heavy traffic or on roads that are winding, icy, snow covered, slippery, or roads with a loose driving surface. Failure to follow this precaution could cause a collision or

**loss of vehicle control, possibly resulting in personal injury or property damage.**

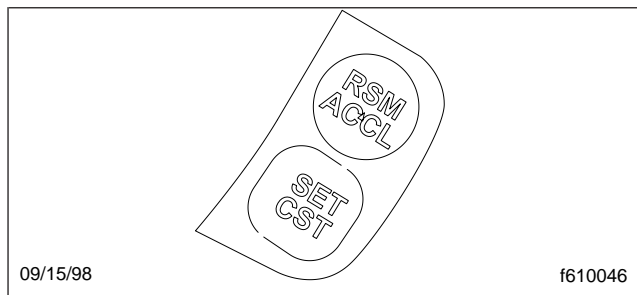
See the engine operation manual for complete details of the cruise control. To turn cruise control on, press the ON button located in the steering wheel. See [Fig. 2.23](#). Cruise control may not operate until a minimum vehicle speed is reached.

To turn the cruise control off, press the OFF button located in the steering wheel. See [Fig. 2.23](#). Also, cruise control will be turned off when the vehicle ignition is turned off. Once cruise control is switched off, the previously programmed set speed will be erased.



**Fig. 2.23, Cruise Control ON/OFF Switch, Optional**

**To Set a Speed** — press SET/CST. See [Fig. 2.24](#).



**Fig. 2.24, Cruise Control RSM/ACCL and SET/CST Switch, Optional**

For the cruise control to operate, the cruise control must be ON. Cruise control may not operate until a minimum vehicle speed is reached. See the manufacturer's engine operation manual for specifics.

If you drive up or down a steep hill, the vehicle speed may vary momentarily slower or faster than the set speed. This is normal.

In mountainous areas, at higher elevations, or when pulling a trailer, the cruise control may not be able to maintain the preset speed in the transmission gear position selected. To maintain a preset speed under

these conditions, downshift the transmission to a lower gear.

**To Raise the Set Speed** — press and hold RSM/ACCL. See [Fig. 2.24](#). Release the control when the desired vehicle speed is reached, or press and release RSM/ACCL. Each press will increase the set speed by 1 mph (1.6 km/h). Or accelerate with your accelerator pedal, then press and release SET/CST.

You can accelerate with the accelerator pedal at any time during speed control usage. Releasing the accelerator pedal will return your vehicle to the previously programmed set speed.

**To Lower the Set Speed** — press and hold SET/CST. See [Fig. 2.24](#). Release the control when the desired speed is reached, or press and release SET/CST. Each press will decrease the set speed by 1 mph (1.6 km/h). Or depress the brake pedal and when the desired vehicle speed is reached, press SET/CST.

**To Disengage the Cruise Control** — depress the brake pedal or depress the clutch (if equipped). Disengaging the cruise control will not erase the previously programmed set speed. Pressing OFF will erase the previously programmed set speed.

**To Return to a Set Speed** — press RSM/ACCL for approximately three seconds. See [Fig. 2.24](#).

Use of radio transmitting equipment that is not FCC approved may cause the cruise control to malfunction. Therefore, use only properly installed FCC approved radio transmitting equipment in your vehicle.

## Stationary Throttle Control

**NOTE:** The following applies to all engines except the Caterpillar 3126.

The cruise control may also be used as a throttle control for PTO applications under the following conditions—

- the parking brake must be set; and
- the clutch and accelerator pedals released.

To operate the control feature:

- Press ON;
- Press and hold the SET/CST button until the desired rpm has been reached;
- Adjust rpm by alternately pressing the SET/CST and RSM/ACCL controls.



# Instruments and Controls Identification

The cruise control now functions as a throttle control.

To turn off the throttle control:

- Press OFF or press the clutch (if equipped) or accelerator pedal.

On the Caterpillar 3126 engine, the PTO will only operate if the vehicle is in neutral. This feature can be overridden by a special service tool; see your dealer or service representative for more information.

## Horn

Your vehicle is equipped with an electric horn and may have an optional air horn. To activate the electric horn, press on the horn pad located in the center of the steering wheel. To activate the air horn, pull the cable located on the ceiling above the driver's seat. Use either horn sparingly. Sound it only when necessary.

## Hazard-Warning-Light Switch

The hazard-warning-light switch is located below the lever on the turn signal switch, and is operated by pulling the tab out. When the tab is pulled out, all of the turn-signal lights and both of the indicator lights on the control panel will flash. To cancel the warning lights, move the turn-signal lever up or down.

## Trailer-Brake Hand Control Valve

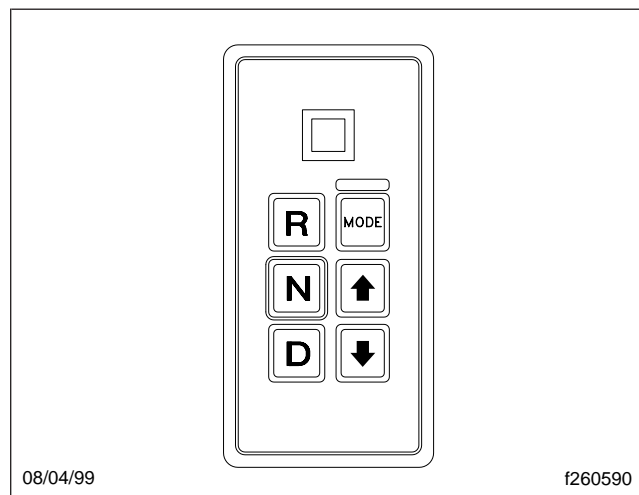
Use this lever for applying the trailer brakes without applying the truck or tractor brakes. The lever is mounted on the dash.

## Transmission Controls

If equipped, the transmission range-control valve and splitter valve are attached to the gearshift knob. Transmission shift-pattern labels are located inside the cab. See [Chapter 8](#) for complete transmission operating instructions.

## Allison Automatic-Transmission Controls

Allison HD-series automatic-transmission models are controlled by an electronic control unit (ECU). The ECU processes information from sensors, pressure switches, and the shift selector to automatically control the transmission according to programmed specifications. See [Fig. 2.25](#).



**Fig. 2.25, Allison Push-Button-Shift Selector**

Vehicles with these transmissions have a red do-not-shift light in the lens and bezel assembly. Also, there is a service light in the indicator panel on the shift selector. With the ignition switch on, both lights come on for a few seconds; then, if there is no problem with the transmission system, the lights will go out. Whenever there is a problem with the transmission system, the lights will come on and stay on as long as the problem exists.

If "Service" is displayed in the indicator panel, some features may not work, but the vehicle can still be driven. If the do-not-shift light comes on while driving (accompanied by eight short beeps from the shift selector), operating limits will be placed on the transmission, such as restricting upshifts and downshifts. However, the vehicle can still be driven to reach service assistance. In either situation, have the problem repaired as soon as possible. See the *Allison Transmission Service Manual* for troubleshooting procedures.

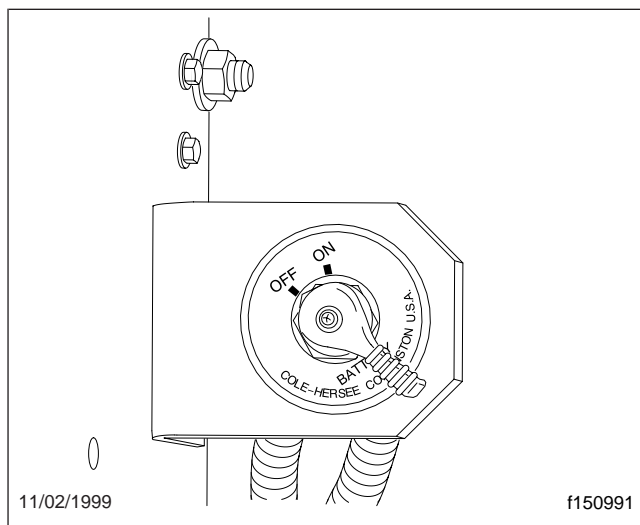
See [Chapter 8](#) for transmission operating instructions.

## Suspension Seat Adjustment Controls

All adjustment controls for a suspension seat are located on the seat base. See [Chapter 5](#) for instructions.

## Battery-Isolation Switch

The battery-isolation switch (see [Fig. 2.26](#)) is located on the cab floor at the left of the driver's seat, or inside the battery box. The battery-isolation switch reduces the power to the cab and engine power wiring. Use it whenever the vehicle is to be put out of service for extended periods.



**Fig. 2.26, Cab (Battery) Isolation Switch**

**IMPORTANT:** The battery isolation switch does not completely isolate the batteries from the electrical system. For service operations that require that the batteries be disconnected, always shut down the engine and remove the negative battery cables.

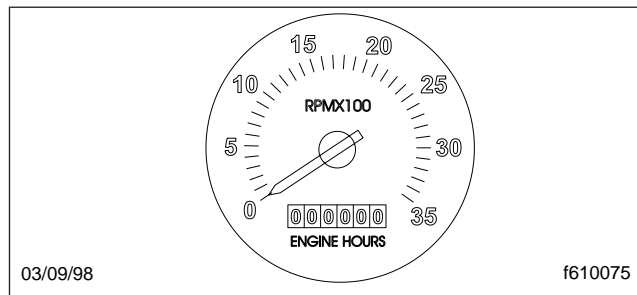
**NOTE:** Whenever battery power is disconnected, clocks and electronically tuned radios must be reset.

## Instruments

### Tachometer/Engine Hours Meter

The tachometer indicates engine speed in hundreds of revolutions per minute (rpm) and serves as a guide for shifting the transmission and for keeping the engine in the appropriate rpm range. See [Fig. 2.27](#).

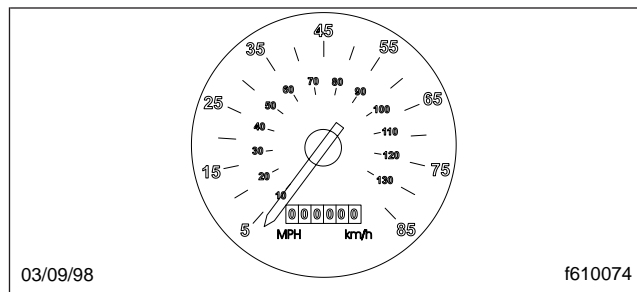
The engine hours meter indicates the total hours the engine has been run.



**Fig. 2.27, Tachometer/Engine Hours Meter**

### Speedometer/Odometer

The speedometer registers speed in both miles per hour (mph) and kilometers per hour (km/h). The odometer indicates the total distance that the vehicle has been driven. See [Fig. 2.28](#).



**Fig. 2.28, Speedometer/Odometer**

### Engine Oil Pressure Gauge



**A sudden decrease or absence of engine oil pressure may indicate mechanical failure. Bring the vehicle to a safe stop, and investigate the cause to prevent further damage. Do not operate the engine until the cause has been determined and corrected.**

Refer to the engine operation manual for the specific safe-operating range for your vehicle. See [Fig. 2.29](#).

### Coolant Temperature Gauge

During normal operation, the coolant temperature gauge should read 180 to 210°F (82 to 99°C). See [Fig. 2.30](#). Refer to the engine operation manual for the specific safe-operating range for your vehicle. If the temperature remains below normal or exceeds

# Instruments and Controls Identification

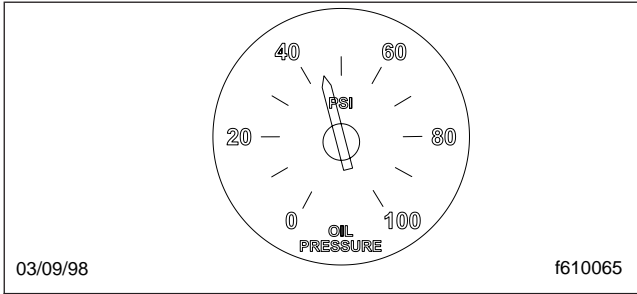


Fig. 2.29, Engine Oil Pressure Gauge

the maximum, inspect the cooling system to determine the cause. See **Group 20** of the *Sterling L-Line and A-Line Workshop Manual* for troubleshooting and repair procedures.

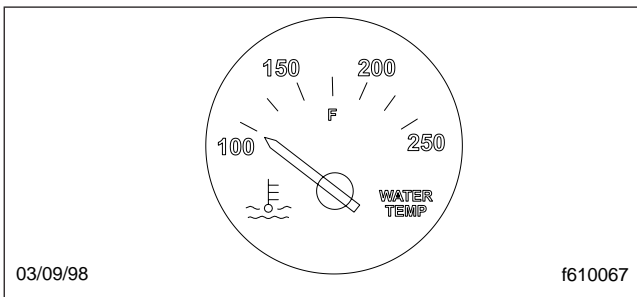


Fig. 2.30, Coolant Temperature Gauge

## Engine Oil Temperature Gauge, Optional



**A sudden increase in engine oil temperature that is not caused by a load increase may indicate mechanical failure. Bring the vehicle to a safe stop, and investigate the cause to prevent further damage. Do not operate the engine until the cause has been determined and corrected.**

During normal operation, the engine oil temperature gauge should read 140 to 230°F (60 to 110°C). See [Fig. 2.31](#).

Under heavy loads, such as when climbing steep grades, temperatures that exceed the normal oil temperature range for a short period are not unusual.

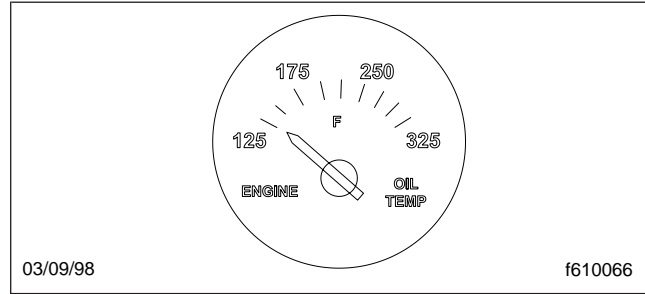


Fig. 2.31, Engine Oil Temperature Gauge, Optional

## Voltmeter



**Gel cell batteries can be damaged if the battery voltage is allowed to drop below 12.0 volts or if the charging voltage is more than 14.1 volts. Start the engine to recharge the gel cell before the battery becomes fully discharged. If an external charger is needed, disconnect the gel cell battery and use only an external battery charger that has been approved for gel cell batteries.**

The voltmeter indicates the vehicle charging system voltage when the engine is running, and the battery voltage when the engine is stopped. See [Fig. 2.32](#). By monitoring the voltmeter, the driver can be aware of potential charging system problems and have them fixed before the batteries discharge enough to create starting difficulties.

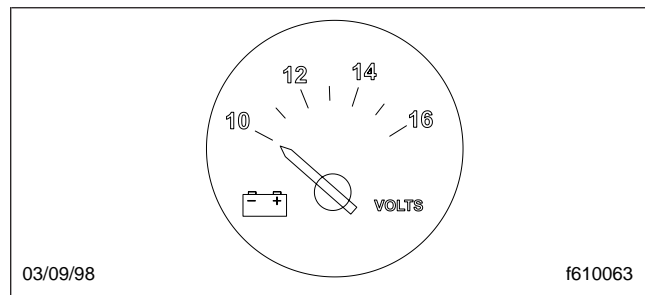


Fig. 2.32, Voltmeter

The voltmeter will normally show approximately 13.7 to 14.1 volts when the engine is running. The voltage of a fully charged battery is 12.7 to 12.8 volts when the engine is stopped. A completely discharged battery will produce only about 12.0 volts. The voltmeter will indicate lower voltage as the vehicle is being

# Instruments and Controls Identification

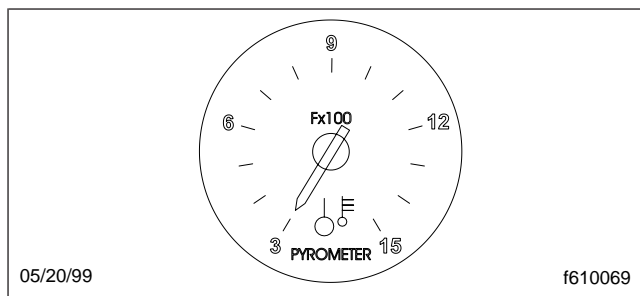
started or when electrical devices in the vehicle are being used.

If the voltmeter shows an undercharged or overcharged condition for an extended period, have the charging system and batteries checked at a repair facility.

On a vehicle equipped with a battery isolator system, the voltmeter measures the average voltage of all of the batteries when the engine is running. When the engine is stopped, the voltmeter shows only the gel cell battery voltage and does not indicate the voltage of the engine-starting batteries.

## Pyrometer, Optional

A pyrometer registers the exhaust temperature near the turbocharger. See [Fig. 2.33](#).

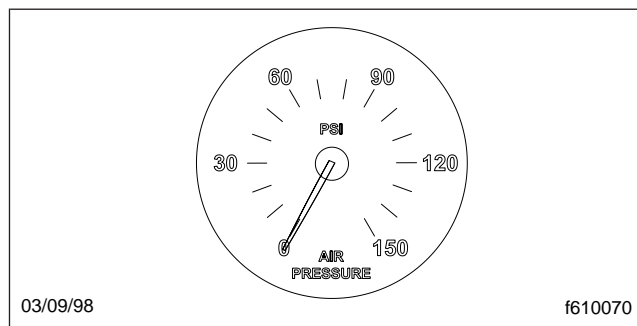


**Fig. 2.33, Pyrometer, Optional**

Variations in engine load can cause exhaust temperatures to vary. If the pyrometer reading shows that exhaust temperature exceeds normal, reduce fuel to the engine until the exhaust temperature is reduced. Shift to a lower gear if the engine is overloaded.

## Primary and Secondary Air Pressure Gauges

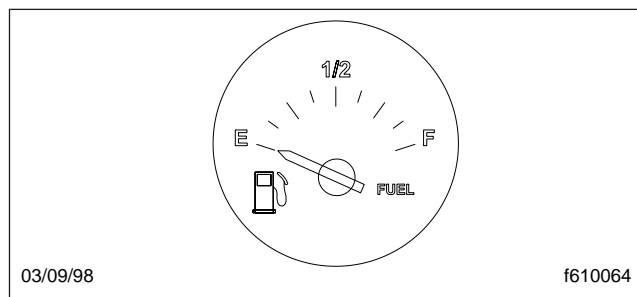
Air pressure gauges register the pressure in the primary (green) and secondary (red) air systems. See [Fig. 2.34](#). Normal pressure, with the engine running, is 100 to 120 psi (689 to 827 kPa) in both systems. A low-air-pressure warning light and buzzer, connected to both the primary and secondary systems, activate when air pressure in either system drops below a minimum pressure of 60 psi (414 kPa). When the engine is started, the warning light and buzzer remain on until air pressure in both systems exceeds minimum pressure.



**Fig. 2.34, Air Pressure Gauges**

## Fuel Gauge

The fuel gauge indicates the level of fuel in the fuel tank(s). See [Fig. 2.35](#).



**Fig. 2.35, Fuel Gauge**

## Transmission Oil Temperature Gauge, Optional



**A sudden increase in transmission oil temperature that is not caused by a load increase may indicate mechanical failure. Bring the vehicle to a safe stop, and investigate the cause to prevent further damage. Do not operate the vehicle until the cause has been determined and corrected.**

During normal operation, the transmission oil temperature gauge reading should not exceed 250°F (121°C). See [Fig. 2.36](#).

# Instruments and Controls Identification

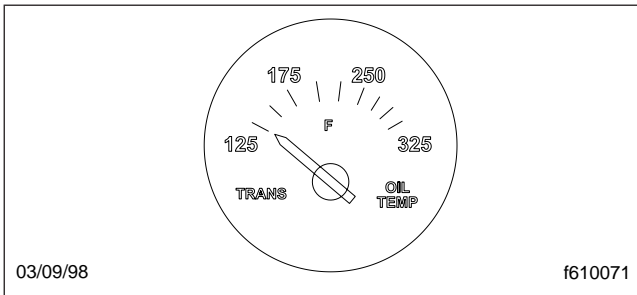


Fig. 2.36, Transmission Oil Temperature Gauge, Optional

## Forward and Rear Axle Oil Temperature Gauges, Optional



A sudden increase in axle oil temperature that is not caused by a load increase may indicate mechanical failure. Bring the vehicle to a safe stop, and investigate the cause to prevent further damage. Do not operate the vehicle until the cause has been determined and corrected.

During normal operation, forward and rear axle oil temperature gauges should read between 150 and 230°F (65 and 110°C). Under heavy loads, such as when climbing steep grades, temperatures up to a maximum of 250°F (121°C) are not unusual. See Fig. 2.37.

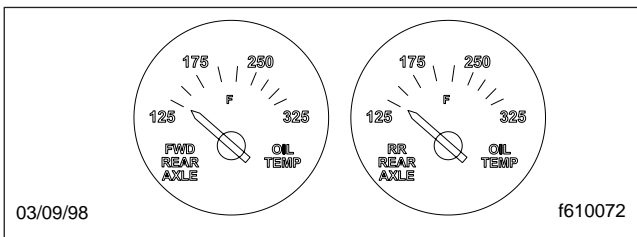


Fig. 2.37, Tandem Axle Oil Temperature Gauges, Optional

## Application Air Pressure Gauge, Optional

An application air pressure gauge registers the air pressure being used to apply the brakes and should be used for reference only. The gauge will not register air pressure until the foot brake pedal is depressed or the trailer hand brake is applied.

## Intake-Air Restriction Gauge, Optional

An intake-air restriction gauge measures the vacuum on the engine side of the air cleaner at the air cleaner outlet. See Fig. 2.38. If the gauge stays locked at or above the service reading in Table 2.1 after the engine is shut down, the air cleaner needs to be serviced. After the air cleaner has been serviced, press the reset button on the gauge.

NOTE: Rain or snow can wet the air filter, which can temporarily cause a higher than normal reading.

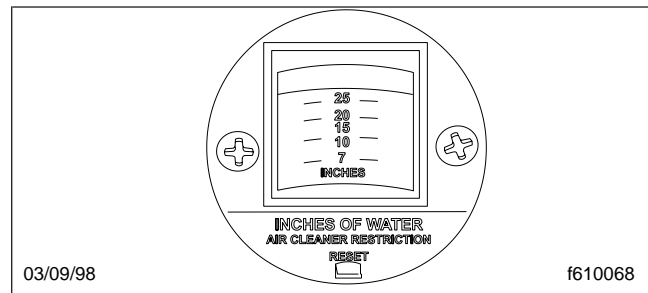


Fig. 2.38, Intake-Air Restriction Gauge, Optional

Intake-Air Restriction Vacuum Readings		
Engine Type*	Initial inH <sub>2</sub> O	Service inH <sub>2</sub> O
Cummins	12	25
Detroit Diesel	12	20
Caterpillar	15	25
Mercedes-Benz	10	22










\* Turbocharged engines must be checked at full load and governed engine speed.

Table 2.1, Intake-Air Restriction Vacuum Readings

## Warning and Indicator Lights

Dash lightbars have warning and indicator lights that may be lettering or icons. Up until December 31, 2006, the warning and indicator lights were a mixture of ISO icons and lettering. Since January 2007, ISO icons are used for all standard warning and indicator lights on the dash lightbar. See Table 2.2 for descriptions of the icons.

# Instruments and Controls Identification

Warning and Indicator Light Icons		
	Check Engine (amber)	Indicates an undesirable engine condition is detected or recorded. The vehicle can still be driven. If the condition gets worse, the stop engine or engine protection light will illuminate.
	Stop Engine or Engine Protect (red)	Indicates a serious fault that requires the engine shut down immediately. The engine ECU will reduce the maximum engine torque and speed, and, if the condition does not improve, will shut down the engine within 30 seconds of the light illuminating. The driver must safely bring the vehicle to a stop on the side of the road and shut down the engine as soon as the red light is seen. If the engine shuts down while the vehicle is in a hazardous location, the engine can be restarted after turning the key to the OFF position for a few seconds.
	High Exhaust System Temperature (HEST) Lamp (amber)	Slow (10-second) flash indicates a regeneration is in progress, and the driver is not controlling the engine idle speed.  Steadily illuminated indicates a regeneration is in progress, with high exhaust temperatures at the outlet of the tail pipe, if the speed is below 5 mph (8 km/h). It does not signify the need for service; it only alerts the vehicle operator of high exhaust temperatures. See the engine operation manual for details.
	Diesel Particulate Filter (DPF) Lamp (amber)	Steadily illuminated indicates a regeneration is required. Change to a more challenging duty cycle, such as highway driving, to raise exhaust temperatures for at least 20 minutes, or perform a parked regeneration. See the engine operation manual for details.  Blinking indicates that a parked regeneration is required immediately. An engine derate and shutdown will occur. See the engine operation manual for details on how to perform a stationary regeneration.
	Malfunction Indicator Lamp (MIL) (amber)	Indicates an engine emissions-related fault, including, but not limited to the aftertreatment system. See the engine operation manual for details.
	Tractor ABS Lamp (amber)	Indicates a problem with the ABS is detected. Repair the tractor ABS immediately to ensure full antilock braking capability.
	Trailer ABS Lamp (amber)	Indicates a fault is detected with the trailer ABS.
	Left-Turn Signal (green)	Flashes on and off whenever the outside turn signal lights are flashing.
	Right-Turn Signal (green)	Flashes on and off whenever the outside turn signal lights are flashing.

# Instruments and Controls Identification











Warning and Indicator Light Icons		
	High-Beam Indicator (blue)	Indicates the headlights are on high beam.
	Low Air Pressure Warning Lamp (red)	Activates with a buzzer when air pressure in the primary or secondary air reservoir falls below 64 to 76 psi (440 to 525 kPa).
	High Coolant Temperature Warning Lamp (red)	Activates with a buzzer when the coolant temperature goes above a maximum level specified by the engine manufacturer (see the engine manual).
	Low Engine Oil Pressure Warning Lamp (red)	Activates with a buzzer when engine oil pressure goes below a minimum level specified by the engine manufacturer (see the engine manual).
	Parking/Emergency Brake Lamp (BRAKE!) (Red)	Indicates the parking brake is engaged, or hydraulic brake fluid pressure is low. A buzzer activates when the vehicle is moving over 2 mph (3 km/h) with the parking brake set.
	Fasten Seat Belt Lamp (red)	Illuminates for 15 seconds when the ignition key is turned to the ON position.
	Intake Heater Lamp (amber)	Indicates the intake air heater is active.
	Water in Fuel Lamp (amber)	Indicates that the fuel could contain water.
	Low Battery Voltage Lamp (red)	Indicates battery voltage is 11.9 volts or less.
	No Charge Lamp (amber)	Indicates an alternator charge output failure.

Table 2.2, Warning and Indicator Light Icons

## Engine Protection

**IMPORTANT:** Drivers of electronically controlled engines should know the extent of the warning/warning-shutdown system before operating the vehicle. This information can be obtained from your dealer.

### Amber Check Engine Warning Lamp

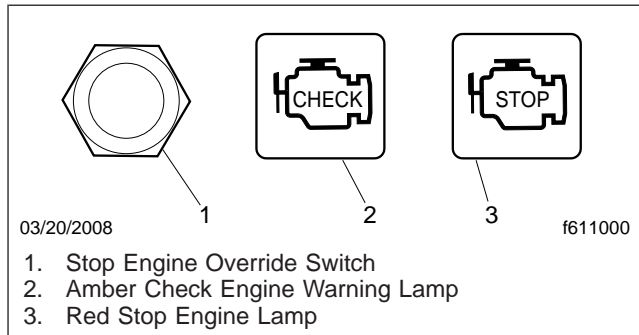
When the amber Check Engine warning lamp comes on for any reason, the vehicle can still be operated, and the driver can proceed to the required destina-

tion. This condition should be reported to an authorized service center as soon as possible. Refer to the engine operation manual for details of the engine protection system in your vehicle. See [Fig. 2.39](#).

### Red Stop Engine Lamp

When the red Stop Engine lamp comes on, the computer has detected a major malfunction in the engine that requires immediate attention. **It is the operator's responsibility to shut down the engine to avoid serious damage. Refer to the engine operation manual for details of the engine protection system in your vehicle.**

# Instruments and Controls Identification



**Fig. 2.39, Engine Protection Warning Lights**

If the engine shuts down while the vehicle is in a hazardous location, the engine can be restarted after turning the key to the OFF position for a few seconds, to allow the driver to move the vehicle to a safe location.

## Stop Engine Override Switch



Using the override button so the engine operates for an extended period may result in engine damage. The operator has the responsibility to take action to avoid engine damage.

The vehicle may be equipped with a Stop Engine Override (SEO) switch, that can be used to override the shutdown sequence. This override resets the shutdown timer, restoring power to the level when the red stop engine lamp was illuminated. The switch must be recycled after five seconds to obtain a subsequent override.

## Instrumentation Control Unit 4 (ICU4)

The ICU4 instrument cluster is an individual gauge cluster, with a lightbar with a driver message display screen, and integrated warning and indicator lights. See [Fig. 2.40](#) for a typical layout of the gauges.

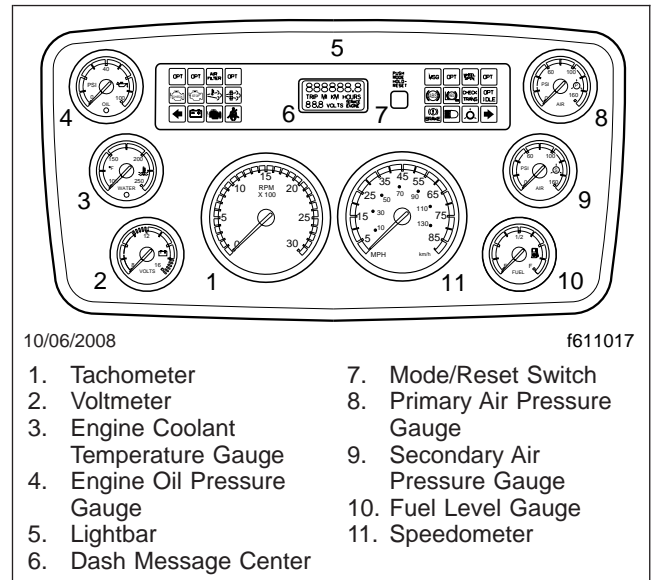
Standard gauges are:

- speedometer
- engine coolant temperature gauge
- engine oil pressure gauge
- voltmeter

- fuel gauge
- air gauges

The following gauges have a warning light on the gauge:

- engine coolant temperature (high)
- engine oil pressure (low)
- fuel level (low)



**Fig. 2.40, ICU4 Instrument Cluster**

## Buzzer and Chime

A buzzer sounds for three seconds during the self-test at start-up, and when the following conditions exist:

- low air pressure
- low oil pressure
- high coolant temperature
- the parking brake is applied and the vehicle is moving at a speed of at least 2 mph (3 km/h)

A chime sounds when the parking brake is off and the door is open, or when the headlights are on and the door is open.



# Instruments and Controls Identification

---

## Ignition Sequence

When the ignition key is turned on, the ICU4 begins a self-test. During this process, all gauges controlled by the cluster sweep to full scale and return, the buzzer sounds for three seconds, the fasten seat belt warning light illuminates for 15 seconds, and the battery voltage, low air pressure, and parking brake warning lights illuminate then turn off. Then the software revision level of the ICU4 is displayed, followed by active faults, if any, then the odometer display.

## Mode/Reset Switch

The mode/reset switch controls the display of the odometer, trip miles and hours, engine miles and hours, service cycle screens, fault code screens, and oil level screens (on some Mercedes-Benz engines; if equipped and enabled).

With the parking brake released, only the basic function screens, which include odometer, trip miles, and trip hours, can be accessed. Park the vehicle and set the parking brake to access additional screen functions.

## Basic Function Screens

When the odometer is displayed, push the mode/reset switch once to display trip distance, and push it again to display trip hours. Both numbers are calculated from the last time the value was reset. Hold the switch when either number is displayed, to reset the value to zero. See [Fig. 2.41](#).

## Diagnostic Screens

During vehicle start-up, with the parking brake on, the ICU4 displays any active fault codes for three seconds each, until the parking brake is released. While the active fault codes are on display, push the mode/reset switch once to display the initial diagnostic screen (DIAG) and the total number of active faults. See [Fig. 2.42](#).

If service cycle screens are enabled, and service distance or time has been exceeded, the text SERVICE will be displayed with the other fault messages. This informs the driver that the service interval has been exceeded, and vehicle service is required.

Specific fault code information can be displayed only while the vehicle is parked and the parking brake is set. When the odometer screen is displayed, push the mode/reset switch until the DIAG screen is dis-

played, then hold the switch to enter the fault code screen sequence. Once the initial fault code is displayed, push the switch to cycle through additional diagnostic codes relating to the first fault. Hold the switch to display additional faults or return to the DIAG screen. If service cycle screens are enabled, service interval information is displayed before fault code information is displayed.

When the word SERVICE appears on the DIAG message display screen, service cycle screens are enabled. Hold the mode/reset switch at the DIAG screen to display miles or hours remaining until the next scheduled service. When MI appears on the DIAG screen, service miles are enabled; when HOURS appears on the screen, service hours are enabled. Either service miles or hours can be enabled, but not both. When service miles or hours has been exceeded, the number flashes to indicate service is overdue.

## Engine Screens

Push the mode/reset switch once following the DIAG screen and the word ENGINE is displayed in the lower right corner of the digital display. Hold the switch to display total engine miles. Push then hold it again to display total engine hours. If OIL LVL is displayed earlier with ENGINE (only on vehicles with Mercedes-Benz engines; if equipped and enabled) hold the switch again to access oil level screens.

## Setup Screens

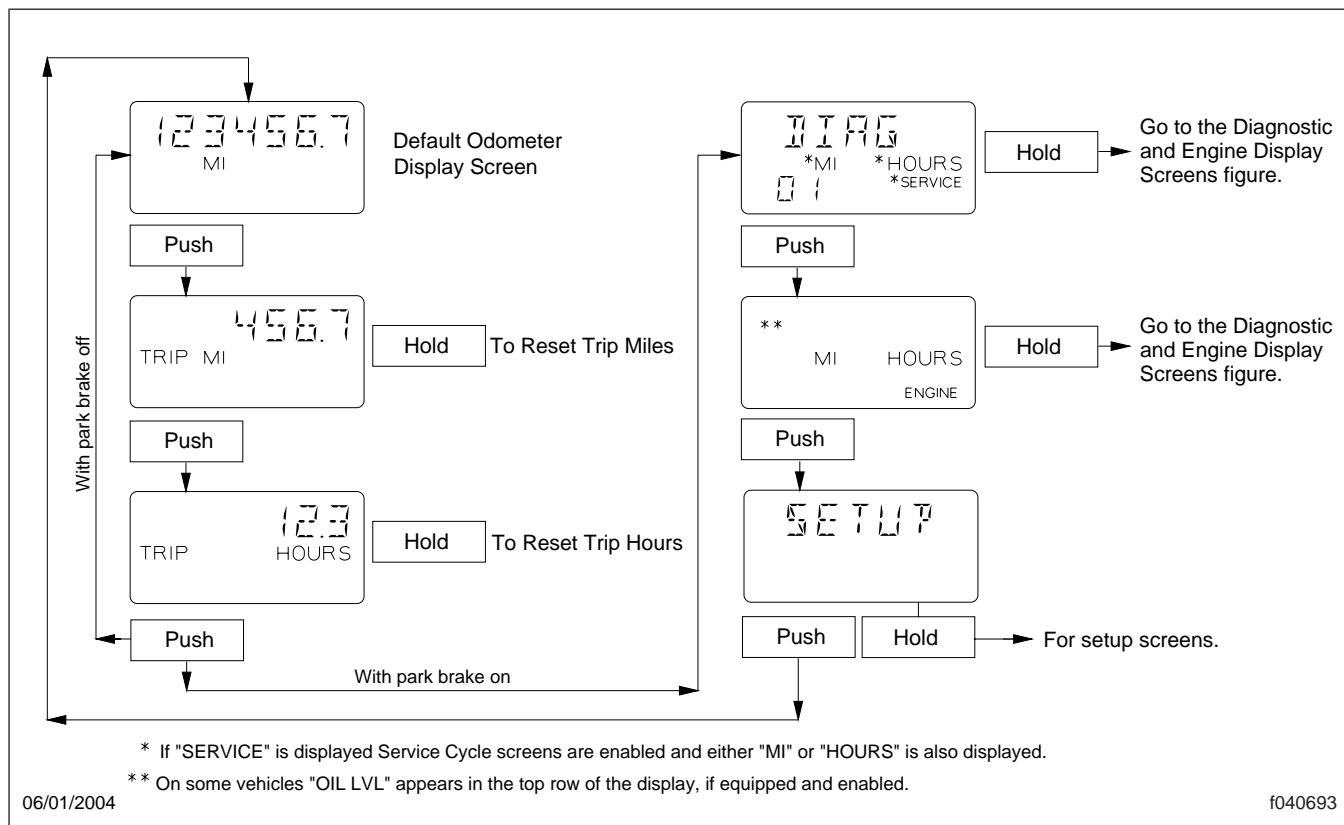
See [Fig. 2.43](#) for setup screens.

Press the mode reset switch while in the engine display screen, to sequence to the SETUP screen. Hold the mode switch while in the SETUP screen, to sequence to the SELECT screen. Hold the mode switch while in SELECT, to toggle between MI or KM as a display preference. Release the mode switch at the desired selection, then press again to reset.

Push the mode switch again to display the temperature warning screen. Hold the mode switch to toggle between ON and OFF. Release the button, then press it again to reset to the desired setting.

Push the mode switch again to sequence to the LCD brightness screen. Hold the mode switch to toggle between ON and OFF. Release the button at the desired setting, then push again to reset.

# Instruments and Controls Identification



**Fig. 2.41, ICU4 Basic Function Screens**

Push the mode switch again to sequence to the service SETUP screen.

To reset the service intervals, hold the mode switch while in the service SETUP screen, to display the RESET screen. Hold the mode switch while in the RESET screen, to display the interval select screen. Hold the mode switch while in the interval select screen, to toggle between MI (KM), or HOURS for selection of the service interval mode. Release the button at the desired setting, then push again to reset.

When MI (KM) is selected, push the mode switch to sequence to the service miles distance select screen. Holding the mode switch for approximately 1-1/2 seconds will display table values. Holding the mode/reset switch for 3 seconds will speed up scrolling through the tables. Release the mode switch when the desired interval flashes, then push the mode/reset switch to select it. When completed, the display will sequence to the odometer display.

When HOURS is selected, push the mode switch to sequence to the service hours time select screen. Holding the mode switch for approximately 1-1/2 seconds will display table values. Holding the mode/reset switch for 3 seconds will speed up scrolling through the tables. Release the mode switch when the desired interval flashes, then push the mode/reset switch to select it. When completed, the display will sequence to the odometer display.

If NO is selected, the display will sequence to the odometer display.

The last screen in the SETUP menu, RESET EE is for resetting certain parameters to the original settings. Hold the mode switch to reset the ABS rollcall, sensor fault codes, and engine oil level screens. Push the mode switch to sequence the display to the odometer setting.



# Instruments and Controls Identification

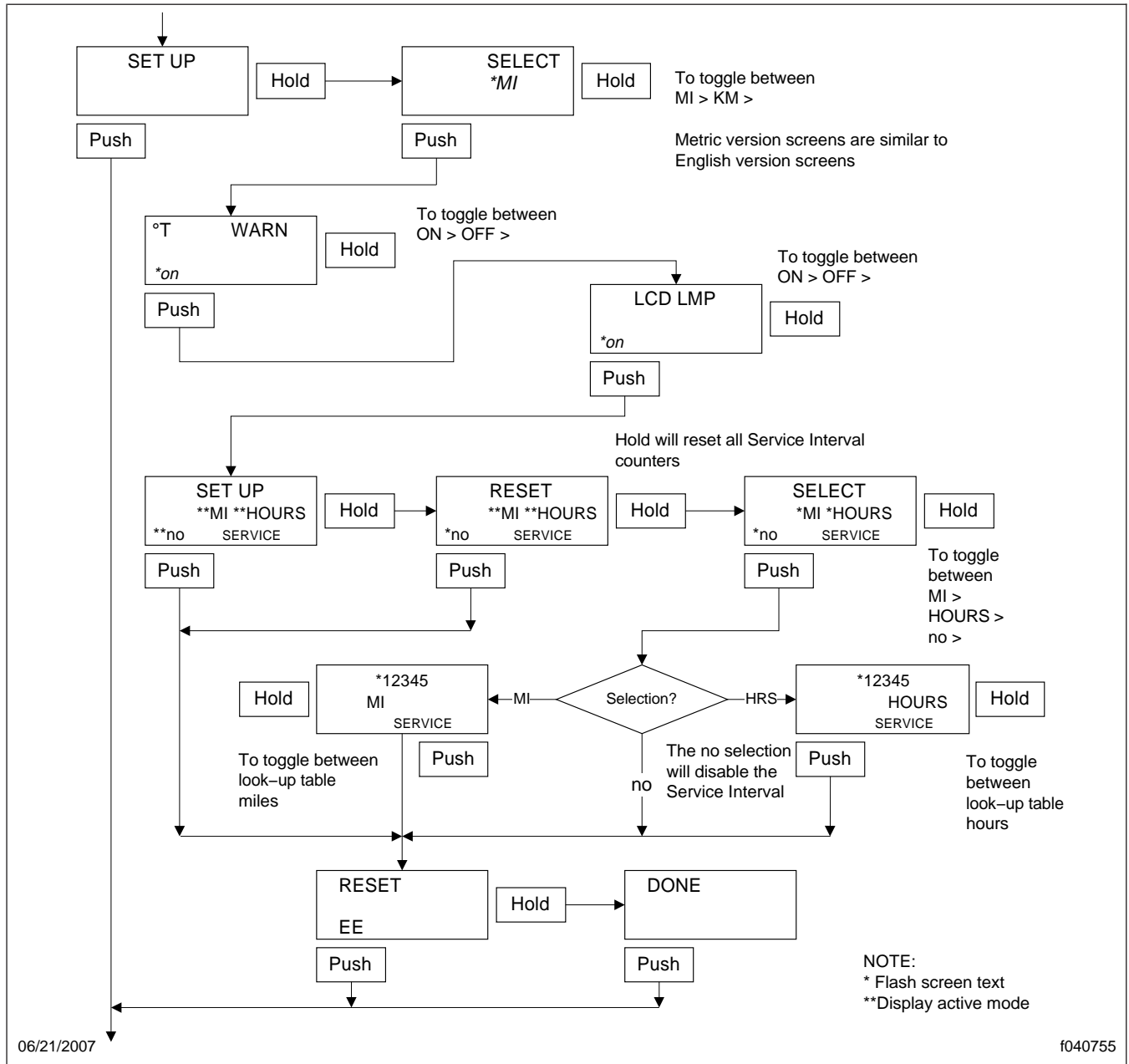


Fig. 2.43, ICU4 Setup Screens

- High Coolant Temperature Warning
- Low Engine Oil Pressure Warning
- Low Air Pressure Warning
- Parking Brake On Indicator
- All engine warning lights, including Engine Protection, Check Engine, and Stop Engine (Cummins only)
- All ABS warning lights, including Wheel Spin, Tractor ABS, and (if installed) Trailer ABS

# Instruments and Controls Identification

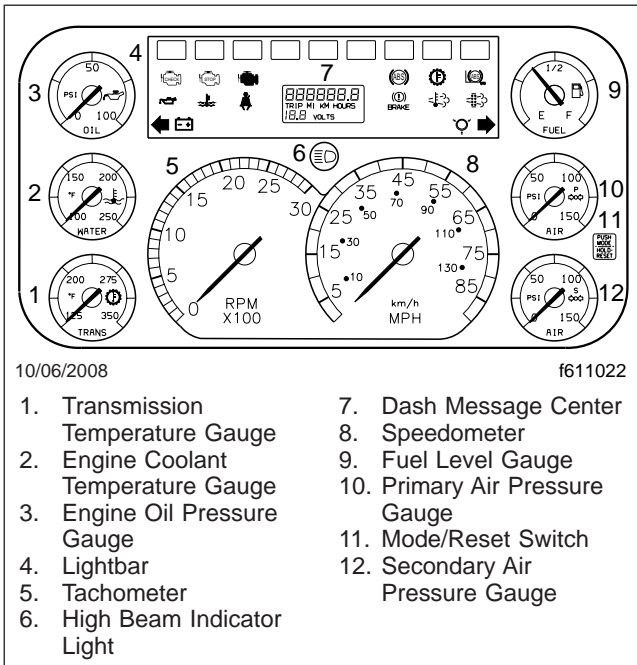


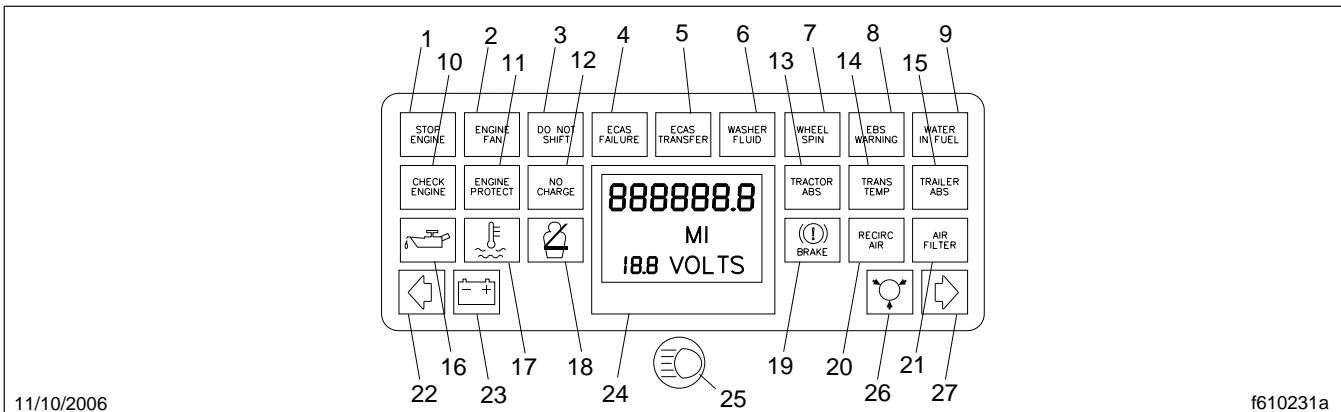
Fig. 2.44, ICU3 (ICU3 '07 shown)

NOTE: When the engine and ABS warning lights go on during the ignition sequence, they are not controlled by the ICU3, but by their own system ECU (electronic control unit).

Once the ignition switch has been turned on, the ICU3 initializes, looking for active faults. During the first half of initialization, all segments of the display illuminate as follows: **888888.8**. The voltmeter display also illuminates, but with the value **18.8**. During the second half of initialization, the software revision level is displayed.

If there are no active faults, the screen displays the odometer.

If the ICU has received active fault codes from other devices, it displays them one after the other until the parking brake is released or the ignition switch is turned off. Once the parking brake is released, the ICU3 displays the odometer again.

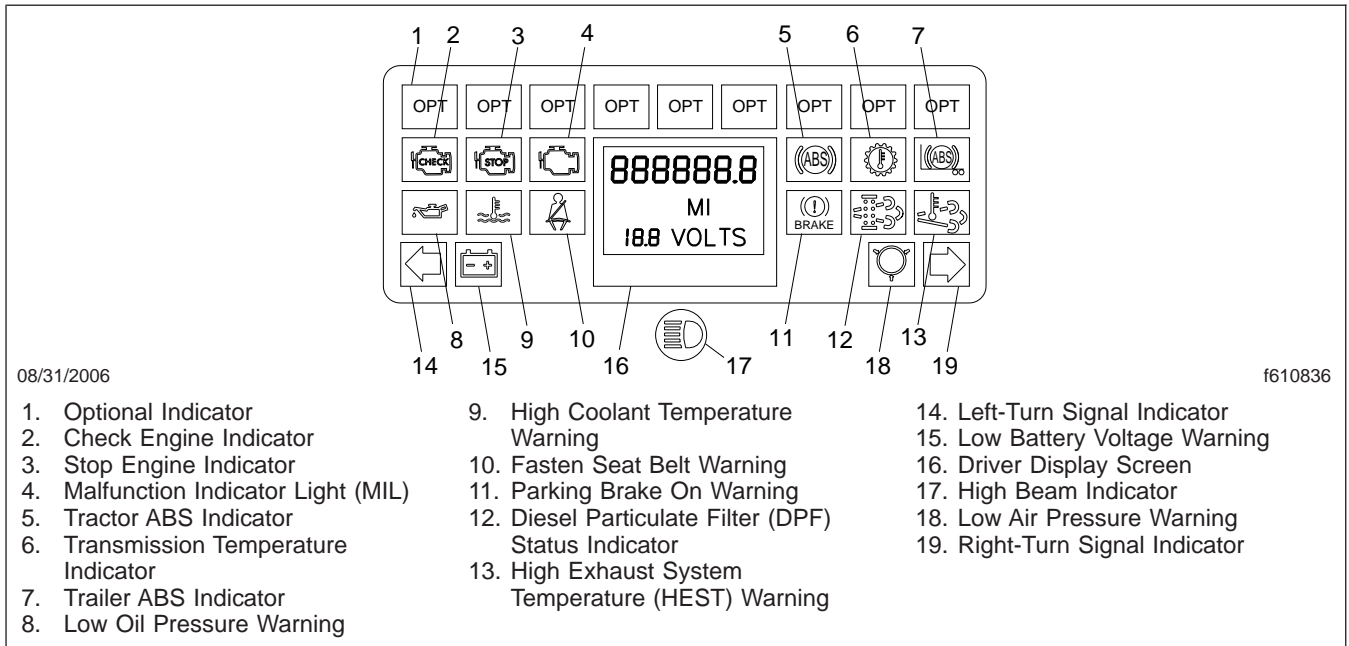


Typical installation shown. Location of legends installed in the top row may vary, and other legends may be specified.

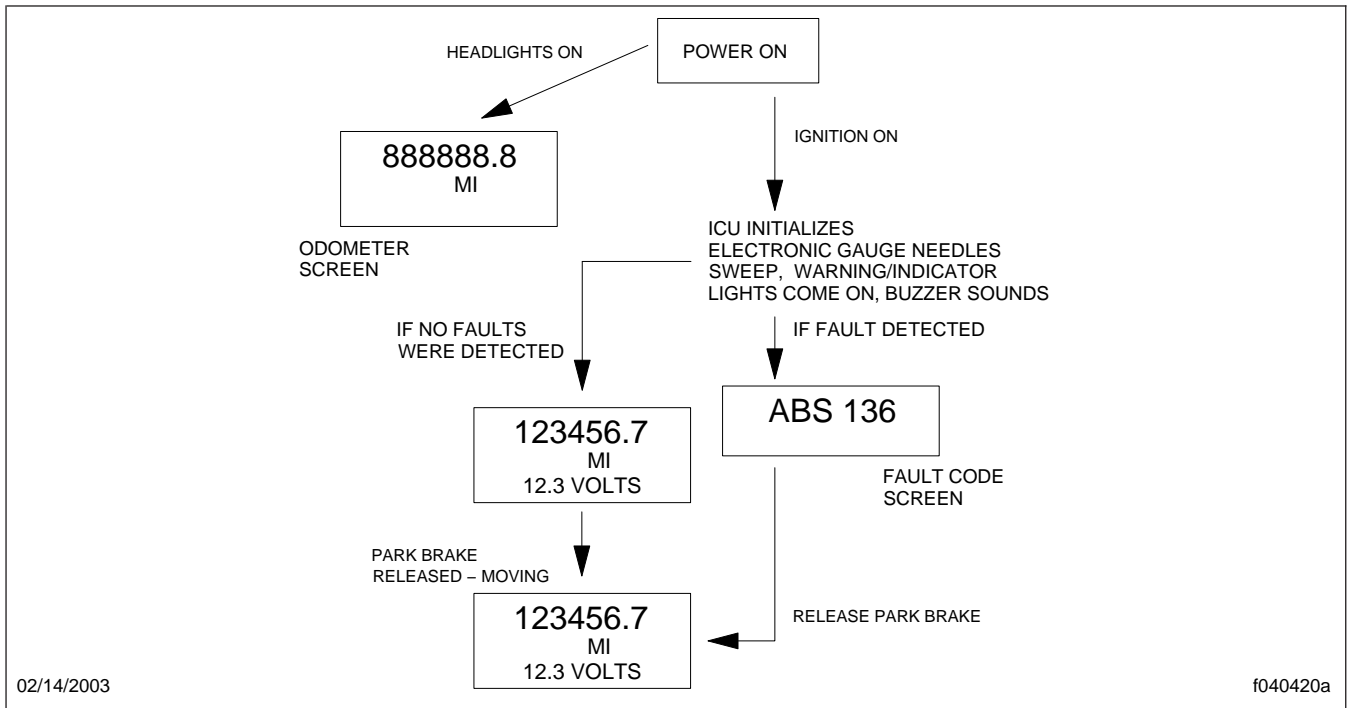
- |  |  |  |
|--|--|--|
| 1. Stop Engine Warning (Cummins engine only) | 10. Check Engine Indicator                     | 18. Fasten Seat Belt Warning             |
| 2. Eng. Fan On Indicator, Optional           | 11. Engine Protection Warning, Optional        | 19. Parking Brake On Warning             |
| 3. Do Not Shift Indicator, Optional          | 12. No Charge Indicator, Optional              | 20. Recirculated Air Indicator, Optional |
| 4. ECAS Failure Warning, Optional            | 13. Tractor ABS Warning                        | 21. Air Restriction Indicator, Optional  |
| 5. ECAS Transfer Indicator, Optional         | 14. Transmission Temperature Warning, Optional | 22. Left-Turn Signal                     |
| 6. Low Washer Fluid Indicator, Optional      | 15. Trailer ABS Warning                        | 23. Low Battery Voltage Warning          |
| 7. Wheel Spin Indicator, Optional            | 16. Low Oil Pressure Warning                   | 24. Dash Driver Display Screen           |
| 8. EBS Warning, Optional                     | 17. High Coolant Temperature Warning           | 25. High Beam Indicator                  |
| 9. Water In Fuel Indicator, Optional         |  | 26. Low Air Pressure Warning             |
|  |  | 27. Right-Turn Signal                    |

Fig. 2.45, Dash Message Center, ICU3

# Instruments and Controls Identification



**Fig. 2.46, Dash Message Center, ICU3 '07**



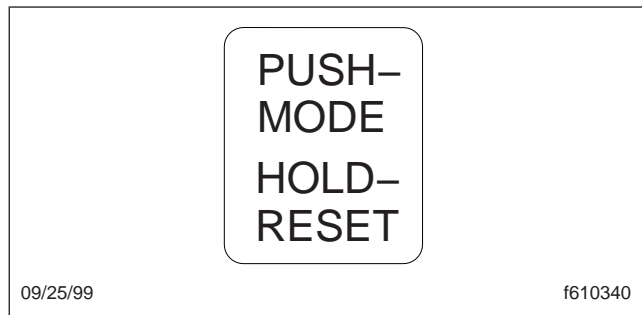
**Fig. 2.47, ICU3 Ignition Sequence**

# Instruments and Controls Identification

---

## Mode/Reset Switch

The mode/reset switch ([Fig. 2.48](#)) is located on the right side of the instrument cluster. The mode/reset switch is used to scroll through the displays on the message display screen, and to reset the trip distance and trip hours values to zero.



**Fig. 2.48, ICU3 Mode/Reset Switch**

See [Fig. 2.49](#) for the ICU3 mode reset cycle.

**NOTE:** The systems diagnostics test is used by trained personnel to retrieve fault codes and other diagnostic information pertaining to the vehicle.

When the odometer reading is displayed and the parking brake is applied:

- Press the mode/reset switch once and the trip distance will display.
- Press the mode/reset switch a second time and the trip hours (engine hours) will display.
- Press the mode/reset switch a third time and the SELECT screen and the current units, MI or KM, will display.
- Press the mode/reset switch a fourth time to return to the odometer reading.

To reset trip miles and/or trip hours to zero, press the mode/reset switch for 1 second or longer. To toggle between MI (miles) or KM (kilometers), press the mode/reset switch while in the SELECT screen.

## NGI Instrument Cluster

### Instruments

The NGI instrument cluster became an option in January of 2002. Each of its gauges is an individually replaceable unit. The instrument control unit (ICU) is

located in the speedometer and receives information from the various sensors installed on the vehicle and feeds it to the electronic gauges. Only the air gauges operate mechanically. See [Fig. 2.50](#).

### Lightbar

The lightbar has three rows of seven warning lights. See [Fig. 2.51](#). The seven telltales on the top row of the lightbar will vary depending on the vehicle configuration and customer preference. The two lower rows contain 14 standard telltales.

### Message Center

The NGI message center is a one-row seven-character liquid crystal display (LCD), located on the speedometer, that displays the following information:

- Odometer
- Trip Odometers (two)
- Engine Hour Meter
- System Diagnostic Menu
- NGI-Specific Warning Messages

The odometer, hour meter, and trip odometers are primary screens. When a primary screen is displayed for 3 seconds or more it becomes the default screen. The default screen is displayed at ignition, and will remain so until manually adjusted using the Mode and Set buttons.

### Mode and Set Buttons

The Mode and Set buttons are located in the lower right corner of the instrument cluster. See [Fig. 2.52](#). Pressing the Mode button cycles through the various functions. Pressing the Set button selects the desired function. See [Fig. 2.53](#). In the Odometer mode, the Set button toggles to MI or KM. In the Trip 1 and 2 Odometer modes, the Set button resets the trip meter to zero. In the Engine Hours mode, total engine hours are displayed. This is not resettable. In the System mode, the Set button initiates the System Diagnostics test and will display any warning messages that are present in the system. To run the system diagnostics, the following conditions must be met:

- ignition on
- parking brake set

# Instruments and Controls Identification

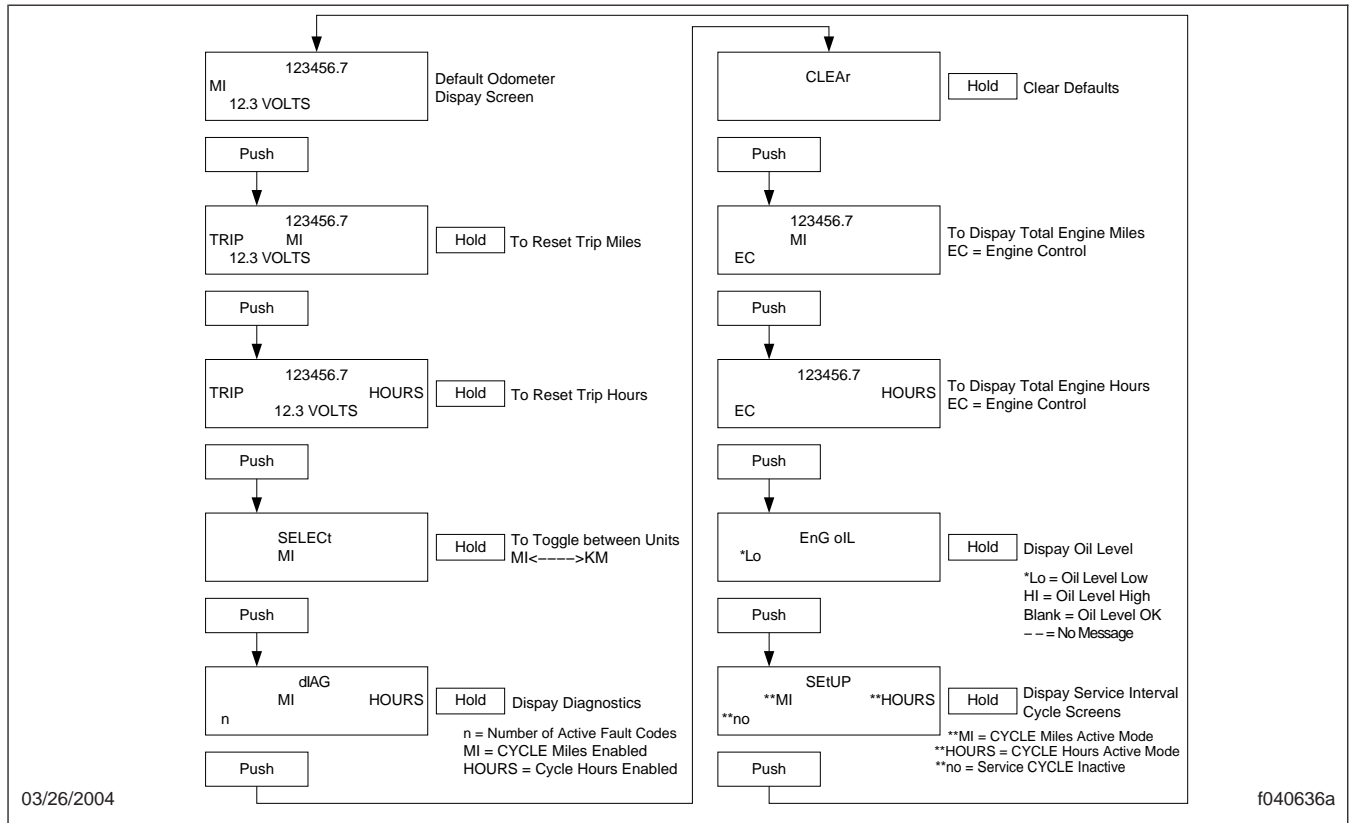


Fig. 2.49, ICU3 Mode Reset Cycle

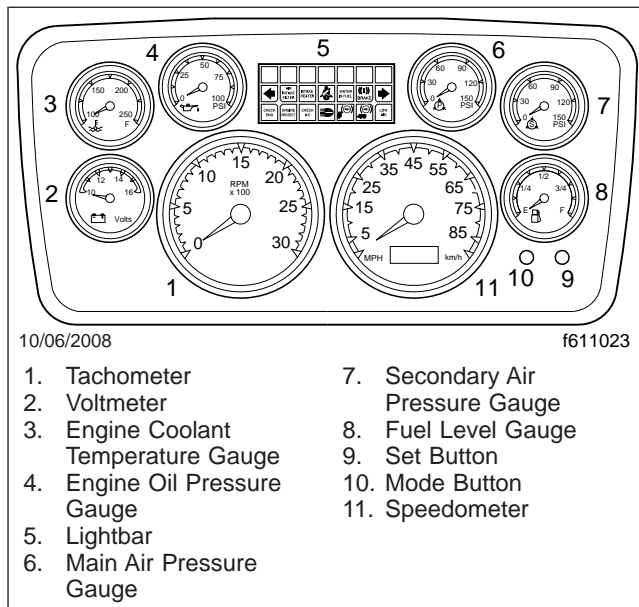


Fig. 2.50, NGI Dash Gauges

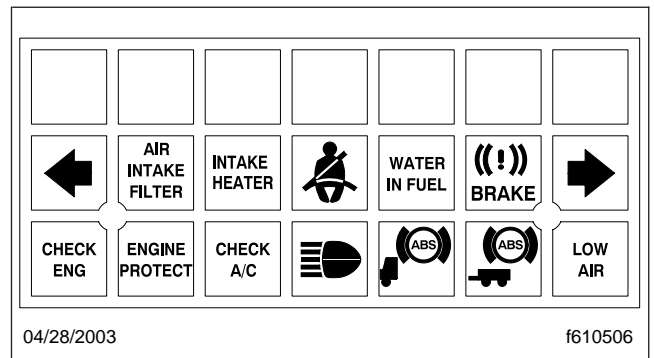


Fig. 2.51, NGI Lightbar

- road speed below 2 mph
- engine rpm at or below 1000
- no low air pressure warning in effect



# Instruments and Controls Identification

NOTE: The systems diagnostics test is used by trained personnel to retrieve fault codes and other diagnostic information pertaining to the vehicle.

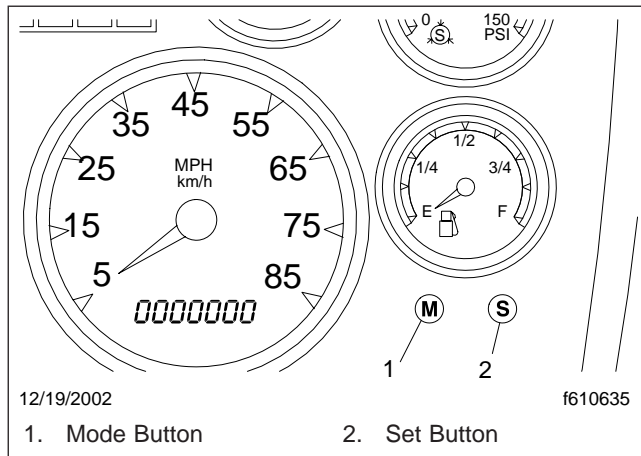


Fig. 2.52, Mode and Set Buttons

## Eaton Vorad

The Eaton VORAD EVT-300 is a computerized collision warning system (CWS) that uses front-mounted and (optional) side-mounted radar to continuously monitor vehicles ahead of and alongside your vehicle.

The system warns of potentially dangerous situations by means of visual and audible alerts. The system performs in fog, rain, snow, dust, smoke, and darkness. To be detected, objects must be within the radar beam's field of view and provide a surface area that can reflect back the radar beam.

The front-looking antenna assembly transmits radar signals to and receives them back from vehicles and objects ahead. This allows the determination of the distance to, relative speed of, and angle to the target of vehicles and objects ahead. The system uses this information to warn the driver of potentially dangerous situations.

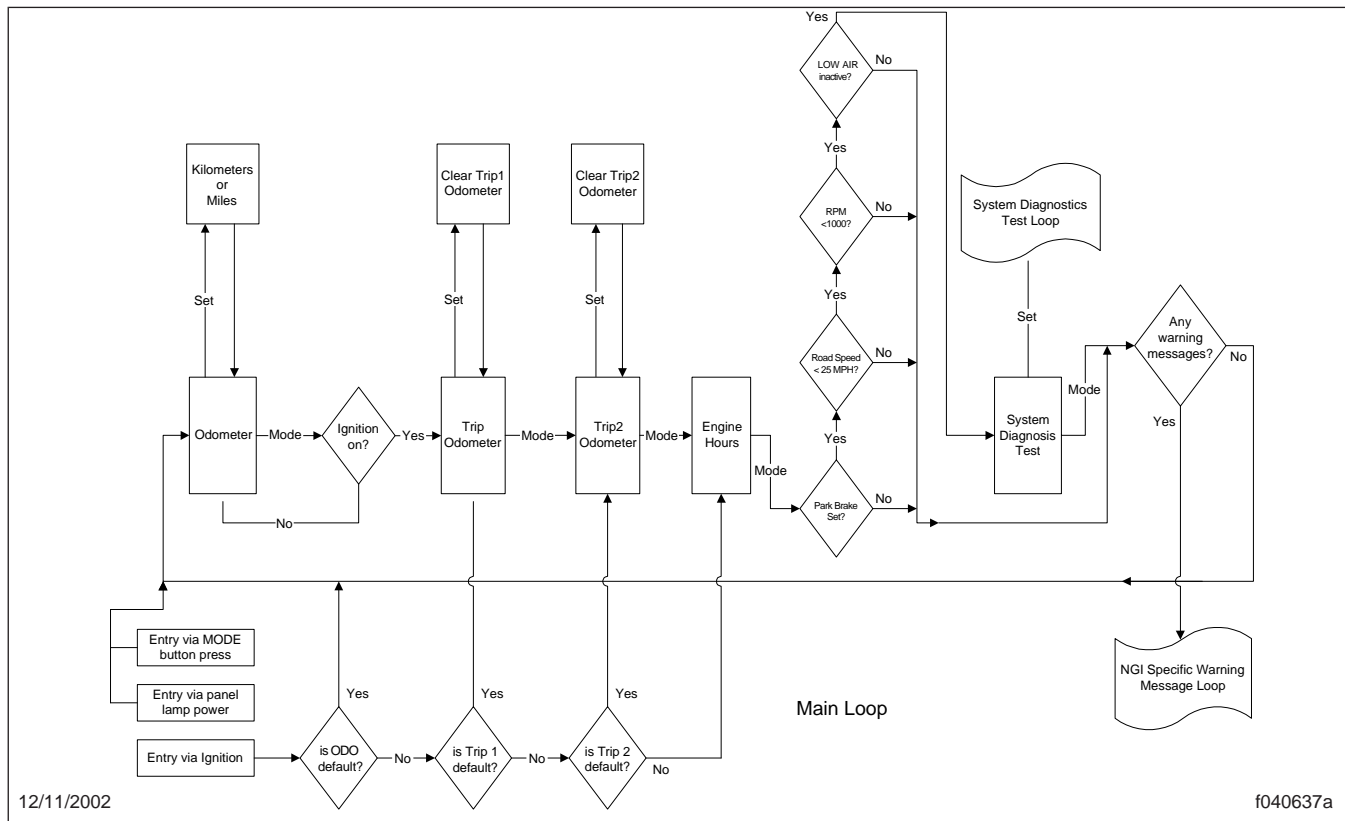


Fig. 2.53, NGI Message Center Display Screens

# Instruments and Controls Identification

Optional side sensors mounted on the side of the vehicle also transmit and receive radar signals for a distance of 2 to 10 feet (0.5 to 3 meters) alongside your vehicle. The side sensors provide a 15 degree vertical by 15 degree horizontal beam pattern. The side sensors can detect unseen vehicles and objects, moving and stationary, adjacent to your vehicle.

## WARNING

**The Eaton VORAD EVT-300 Collision Warning System (CWS) is intended solely as an aid for an alert and conscientious professional driver. It is not intended to be used or relied on to operate a vehicle. Use the system in conjunction with rear-view mirrors and other instrumentation to safely operate the vehicle. Operate this vehicle, equipped with the EVT-300 Collision Warning System, in the same safe manner as if the EVT-300 Collision Warning System were not present.**

**The EVT-300 Collision Warning System is not a substitute for safe, normal driving procedures, nor will it compensate for any driver impairment, such as drugs, alcohol, or fatigue.**

**The EVT-300 Collision Warning System may provide little or no warning of hazards such as pedestrians, animals, oncoming vehicles, or cross traffic.**

**Failure to drive safely and use the system properly could result in personal injury and/or death and severe property damage.**

## Driver Display Unit (DDU)

NOTE: All system controls are located on the DDU. See [Fig. 2.54](#). Indicators to inform the driver about the system's operation are located on both the DDU and the optional side sensor display.

The DDU controls system power, range for vehicle warnings, speaker volume, and all other system functions. At the lower front edge of the DDU, a slot is provided to insert the optional driver's identification card. Alert and indicator lights advise of multiple warning levels, system power, system failure, and if configured, failure of the driver to insert the identification card.

A light sensor automatically adjusts alert and indicator light brightness depending on cab lighting condi-

tions. A small speaker provides audible alert tones to warn of closing on an object ahead, and when equipped with an optional side sensor, of objects alongside when the turn signal is activated in preparation for a lane change. Additional tones indicate speaker volume, system failure, driver's card status, and data extraction pass or fail.

1. The green power-on/driver's card (optional) status indicator light illuminates when the system is activated and the power-on LED test is complete. If the system is configured to require that the driver's card be read, and it is not, the ON light blinks continuously.
2. Push in the volume control and power ON/OFF knob to turn power on or off. Turn the knob left or right to increase or decrease speaker volume. Press and hold the knob for 5 seconds and then release it to activate the failure display mode.

NOTE: The system may be configured to have no on/off capability and the volume may be configured to allow only some volume control.

3. The speaker is located under the top cover of the DDU. It sounds audible tones to alert the driver to potential hazards. Volume may be restricted to a range above a minimum level.

NOTE: This is a configurable electronic parameter.

4. Rotate the range knob (if enabled) to change the first alert detection range from 3 to 2 seconds. This will also change the second alert detection range from 2 to 1.75 seconds. Push and hold the knob for 5 seconds to activate the accident reconstruction function and freeze the most recent data in half of the allocated memory.

NOTE: The system may be configured to prevent adjustment of the range levels.

5. The red system-failure indicator light illuminates if a system problem is detected. Press and hold the volume control knob for 5 seconds to display fault codes. The fault codes will be blinked out as a pattern of flashes on this indicator light. See [Table 2.3](#) for fault codes.

# Instruments and Controls Identification

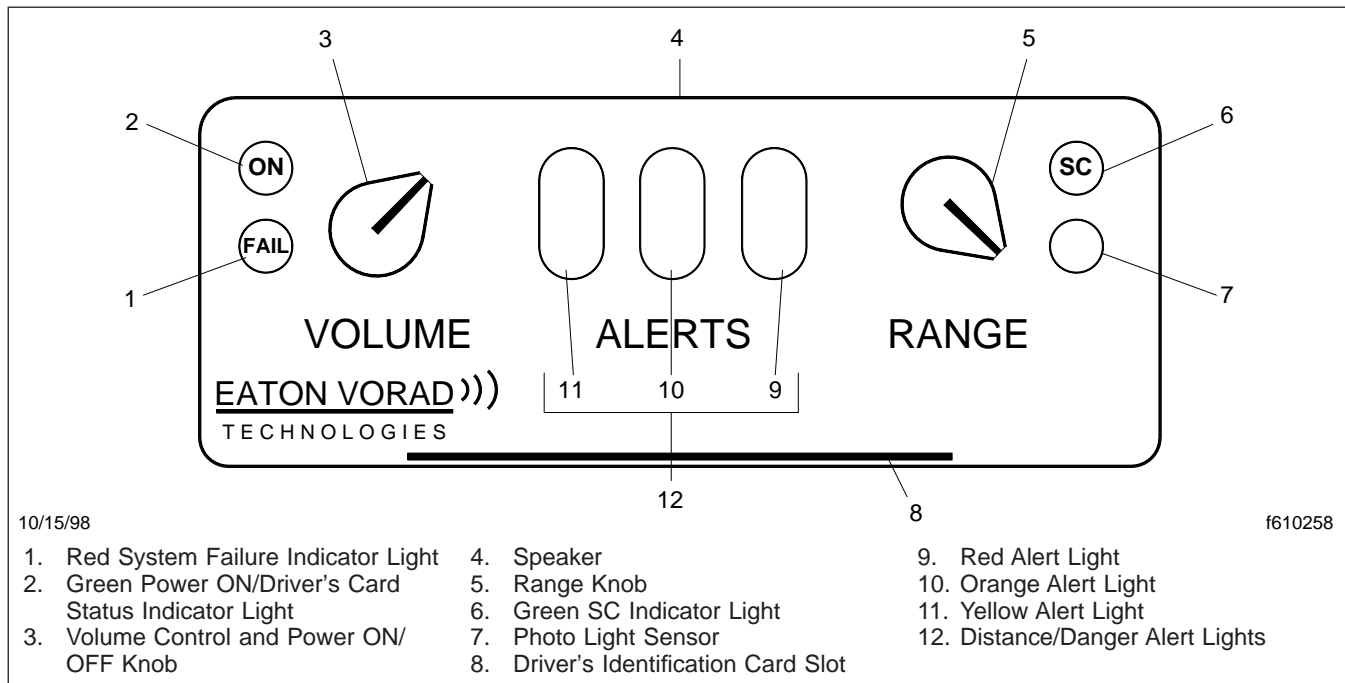


Fig. 2.54, Driver Display Unit, EVT-300

Fault Codes (blink codes)	
Fault Code	Suspect Failure
11	Central Processing Unit (CPU)
12	CyberCard
13	Driver Display Unit (DDU)
14	Antenna Assembly
15	Right Side Sensor
16	Left Side Sensor
21	Right-Turn Signal
22	Left-Turn Signal
23	Brake
24	Speed
25	SmartCruise
31	J1587
32	J1939
33	VBUS
34	DDU Communications
35	Antenna Assembly Communications
41	No Fault or End of Fault Codes

Table 2.3, Fault Codes or Blink Codes

6. The green SC indicator light will flash 8 times if the range knob is pressed to store accident reconstruction information. It will also flash 8 times

after the system is activated, after the power-on LED test is finished, and if accident reconstruction data was previously stored.

7. The photo light sensor senses lighting conditions in the cab and automatically adjusts the intensity of the indicator and alert lights.
8. If the system's configuration requires, insert the driver's identification card in the slot at the lower front edge of the DDU. A high-pitched tone will sound when the driver's identification card has been successfully read. One low tone will sound if the driver's card has been unsuccessfully read. If configured, a repeated low tone will sound if the system is on and the requested driver's card has not been inserted.
9. The yellow alert light illuminates when an object is detected within the system's maximum range of 350 feet (107 meters) on a straight road. Range is reduced in curves by the turn radius of the curve. This light also illuminates when the proximity alarm threshold is crossed.
10. The yellow and orange alert lights illuminate when your vehicle is within a 3-second following interval behind another vehicle in the same lane. If you are within a 2-second following interval

# Instruments and Controls Identification

and closing on the vehicle ahead, a warning tone will also sound.

11. The yellow, orange, and red alert lights illuminate when you are 1 second (and less than 1 second) behind a vehicle. If the vehicle ahead is opening the interval, no tone will sound. If you are closing the interval, double tones will sound. Within a 1/2-second or less following interval, opening or closing, the tones will repeat twice per second.
12. If a stationary vehicle or object, or an object moving less than 3.4 mph (5.5 km/h) in the same lane is detected within 220 feet (67 meters) and within 3 seconds, all three alert lights will illuminate and the double tones will sound. This warning overrides all others and is not affected by the range control knob setting.

**IMPORTANT:** The system is disabled in turns with a radius of less than 750 feet (230 meters) and when the brakes are applied.

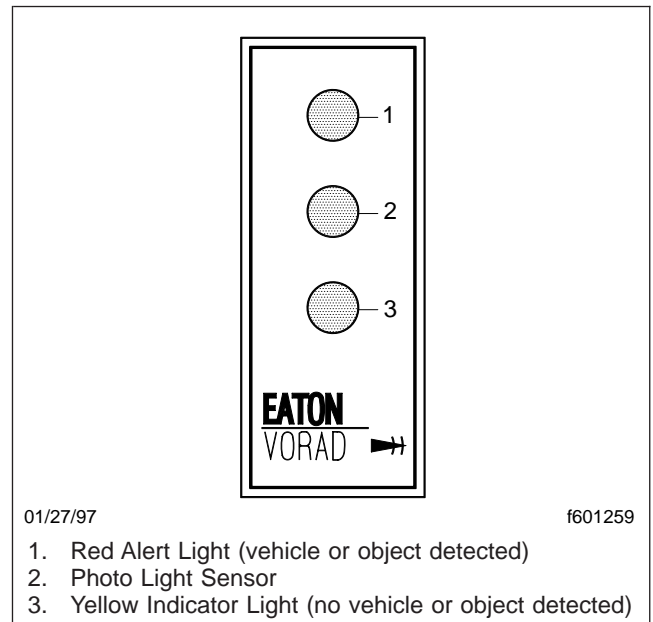
13. If your vehicle is traveling less than 2 mph (3 km/h) and an object is detected less than 15 feet (4.5 meters) in front of your vehicle, and the closing rate is more than 1/2 mph (1 km/h), the yellow alert light will illuminate and a low-frequency double tone will sound. This is the proximity alert.

**NOTE:** All warnings apply only to objects within the maximum detection range and in your lane. Proximity alert tones and vehicle-closing 1/2-second and 2-second following-interval tones are configured items. All tones are disabled in sharp turns or when the brakes are applied. If the configuration permits, the 3-second and 2-second alert levels may be adjusted with the range control knob. A single low-frequency tone sounds when a system failure is detected. A medium-frequency tone sounds when the volume control level is changed. Successful downloading of Eaton Vehicle Information Management System (EVIMS) data will cause a double tone to sound. Unsuccessful downloading will cause a low-frequency tone to sound.

14. A failure of the optional side sensor(s) will cause a continuous red light on the side sensor display to appear.

## Side Sensor Display, Optional

1. The yellow indicator light illuminates continuously when no vehicle is detected by the side sensor(s). See [Fig. 2.55](#).



**Fig. 2.55, Side Sensor Display, Optional**

2. The photo light sensor senses lighting conditions in the cab and automatically adjusts the intensity of indicator and alert lights.
3. The red alert light illuminates when objects are detected by the side sensor(s). If the right turn signal is activated and the side sensor detects an object, the red alert light will illuminate and the DDU speaker will sound a high-frequency double tone. This tone is sounded only once per activation of the turn signal. The red light will also illuminate and stay on if a failure of the side sensor is detected.

## Special Road Situations



**The Eaton VORAD EVT-300 Collision Warning System (CWS) is intended solely as an aid for an alert and conscientious professional driver. It is not intended to be used or relied on to operate a**

# Instruments and Controls Identification

---

vehicle. Use the system in conjunction with rear-view mirrors and other instrumentation to safely operate the vehicle. This system will not warn of many possible hazards. Do not assume it is "all clear" if no alert lights are illuminated.

**Failure to drive safely and use the system properly could result in personal injury and/or death and severe property damage.**

Certain special road situations may affect the system's ability to detect objects. These situations include the effects of curves, dips, and hills, which can provide an unexpected result:

**NOTE:** A warning may sound when an object is detected in front of the vehicle even though the driver intends to turn away or stop before reaching the object.

- When an object is detected in a very sharp right- or left-hand turn, the audible alarm will not sound.
- When approaching a curve, before turning into it, alarms may sound and lights illuminate because of an object off the road, directly in line with your vehicle. This will not occur when the brakes are applied.
- Elevated obstacles, such as overpasses and overhead signs, may be detected when approaching a roadway descending to a lower elevation.
- Vehicles cannot be detected on the other side of a hill. An alarm will not sound until the object is within the antenna assembly's field of view.
- On approaching a steep hill, objects above the beam cannot be detected. Generally, the beam hitting the road surface does not cause an alarm.
- The side sensor only detects objects within its field of view next to the tractor. A vehicle farther back behind the field of view will not be detected.
- The side sensor range is set to detect average-sized vehicles 2 to 10 feet (0.5 to 3 meters) away in the adjacent lane. The side sensor provides a 15 degree vertical by 15 degree horizontal beam pattern.
- The radar beam of the CWS will detect near range cut-ins of approximately 30 feet (9

meters) or less, depending on the angle of entrance into the lane in front of your vehicle.



**Heavy rain or water spray at the side sensor may temporarily prevent the system from providing adequate warnings.**

**Failure to drive safely and use the system properly could result in personal injury and/or death and severe property damage.**

**NOTE:** A continuous fixed object on the right side of the vehicle, such as a guard rail, wall, tunnel, or bridge, may cause the side sensor alert light to stay on.

## In Case of Accident

The optional vehicle accident reconstruction capability provides two segments of system data, one of which can be stored in system memory. Push and hold the DDU range knob for at least 5 seconds to store the first segment. Within 6 seconds, the green SC indicator light will blink rapidly 8 times confirming that the data has been saved. If the range knob is pushed again, a fail tone will sound. After the first segment is saved, the second segment runs continuously, but only contains the last 10 minutes (approximately) of system data. The system will cease recording data 30 seconds after the vehicle comes to a stop.

**NOTE:** Once the first memory segment is frozen, the other can't be frozen. Only by disconnecting the main CPU connector can the second memory segment be preserved. If you desire immediate downloading and interpretation of accident reconstruction data, you must return the CPU to Eaton VORAD. However, after 30 days the frozen information will automatically clear if the vehicle is driven.

## Maintenance and Diagnostics

1. Keep the antenna assembly and side sensor(s) free of a buildup of mud, dirt, ice, or other debris that might reduce the system's range.
2. The system tests itself continuously and evaluates the results every 15 seconds. If a problem is detected with the front radar system, the red

FAIL light on the DDU illuminates continuously as long as the failure is active. The corresponding fault code is stored in the CPU's memory.

- Both active and inactive fault codes can be indicated by the DDU when the system is placed in failure display mode. Inactive faults are those that have occurred and have cleared. Active faults are still present. Fault codes provide the driver the ability to record the system faults during a trip and to notify his/her maintenance department or Eaton VORAD. See "Failure Display Mode/Fault Codes" below. In this mode, specific fault codes are indicated by the pattern of blinks of the driver display unit red FAIL light.
- Each fault code is a two-digit number, as shown in [Table 2.3](#). The red FAIL light blinks the same number of times as the first digit, a pause of approximately 3/4 of a second follows, then the light blinks the same number of times as the second digit.
- Additional fault codes are blinked out at intervals of approximately 3 seconds. After all of the fault codes have been blinked out, a code 41 will be blinked out.

## Failure Display Mode/Fault Codes

NOTE: If the vehicle does not have ON/OFF control on the DDU, press and hold the volume knob after the ignition key is turned on and the 15-second self-test is complete.

- Press and hold the DDU volume control and power ON/OFF knob for at least 9 seconds. The system will turn off if you release the knob before 9 seconds. After 9 seconds, the DDU FAIL light begins to blink out the fault codes. After a 3-second interval, additional fault codes, if present, will be blinked out. A code 41 will be blinked out either if no faults are found or when all fault codes have been blinked out.
- Position the DDU range knob to the left to blink active fault codes and to the right to blink inactive codes.
- To review, test, and clear all fault codes from system memory, use a hand-held diagnostic tool or ServiceRanger.

## Roll Stability Control

Roll Stability Control is an onboard system capable of automatically slowing the vehicle to reduce the risk of rollover. The goal of the system is to reduce rollover accidents by reducing vehicle speed.

The system uses a lateral acceleration sensor that monitors rollover risk. If the sensor detects the vehicle is at risk of rolling over, Roll Stability Control intervenes and attempts to reduce vehicle speed by reducing engine power, applying the engine brake, and/or applying the tractor and trailer brakes.

### WARNING

**The Roll-Stability Control system is intended only as an aid for a conscientious and alert driver. Carefully read the information in this manual to understand this system and its limitations. Do not rely solely on the system to safely operate the vehicle. The system cannot prevent an accident if the driver is impaired or not driving safely.**

**The Roll-Stability Control system is not a substitute for safe driving procedures. Failure to drive safely and use the system properly could result in personal injury and/or death and property damage.**

A decal ([Fig. 2.56](#)) on the auxiliary dash panel and an amber-colored dash indicator light ([Fig. 2.57](#)) indicate that the vehicle is equipped with the Roll Stability Control system. The dash indicator light illuminates whenever the Roll Stability Control system intervenes.

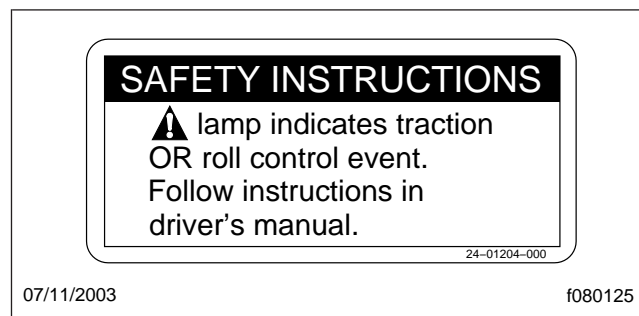


Fig. 2.56, Roll Stability Control Dash Decal

# Instruments and Controls Identification

---



**Fig. 2.57, Roll Stability Control Dash Indicator Light**

# 3

## Vehicle Access

---

Ignition and Lock Key .....	3.1
Cab Door Locks and Handles .....	3.1
Grab Handles and Access Steps .....	3.1
Door Windows .....	3.3
Sleeper Compartment Vents .....	3.3
Power Distribution Module and Power Distribution Box .....	3.4
Cab-to-Sleeper Access .....	3.5
Sleeper Bunk Latches .....	3.6
Sleeper Compartment Exit Door .....	3.6
Baggage Compartment Doors .....	3.7
Back-of-Cab Grab Handles, Steps, and Deck Plate .....	3.7
Battery Box Cover .....	3.8
Hood Tilting .....	3.8



# Vehicle Access

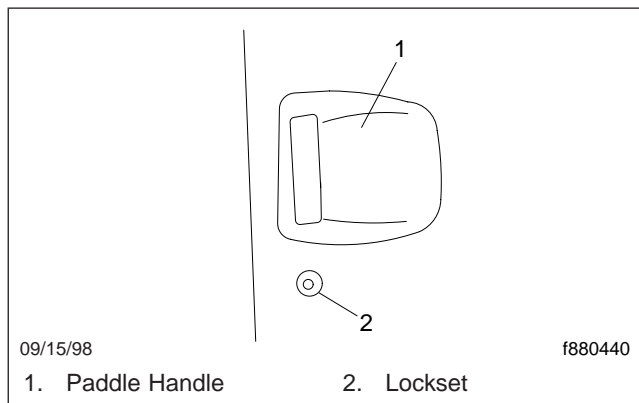
## Ignition and Lock Key

One key operates the ignition switch and all of the door locks.

**IMPORTANT:** Each key is numbered. Record the number so, if needed, a duplicate key can be made.

## Cab Door Locks and Handles

To unlock the left-side door from outside the cab, insert the key in the lockset and turn it one-quarter turn clockwise (**Fig. 3.1**). Turn the key counterclockwise to the original position to remove it. Pull out on the paddle handle to open the door (**Fig. 3.1**).



**Fig. 3.1, Exterior Door Handle**

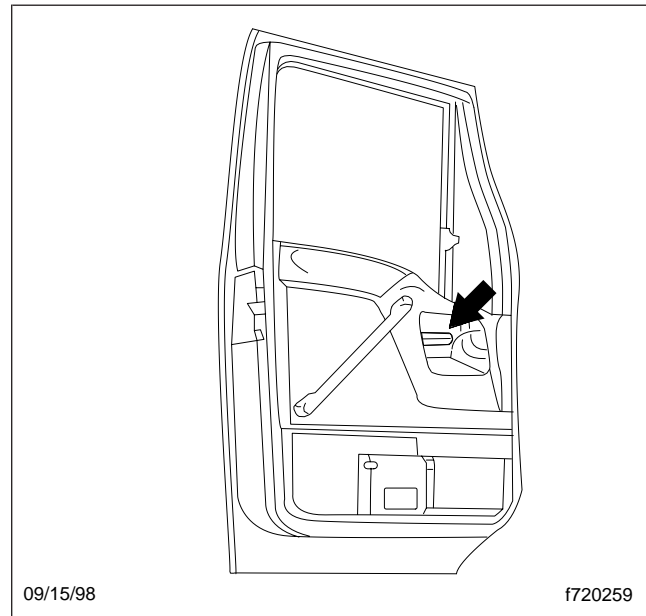
To unlock the right-side door from outside the cab, insert the key in the lockset and turn it one-quarter turn counterclockwise. Turn the key to the original position to remove it.

**NOTE:** The cab door locks can be operated when the doors are open.

To lock a door from outside the cab, insert the key in the lockset and turn it opposite the unlocking direction, then close the door if it is open. Or, push down the inside lock button, then close the door.

To lock either door from inside the cab, push down the lock button, then close the door if it is open. Pull the integral grab bar when closing the door.

To open the door from the inside, pull the door handle toward you (**Fig. 3.2**). This will unlatch the door whether or not it is locked. To unlock the door without unlatching it, pull the lock button up.



**Fig. 3.2, Door Handle**

## Grab Handles and Access Steps

### **WARNING**

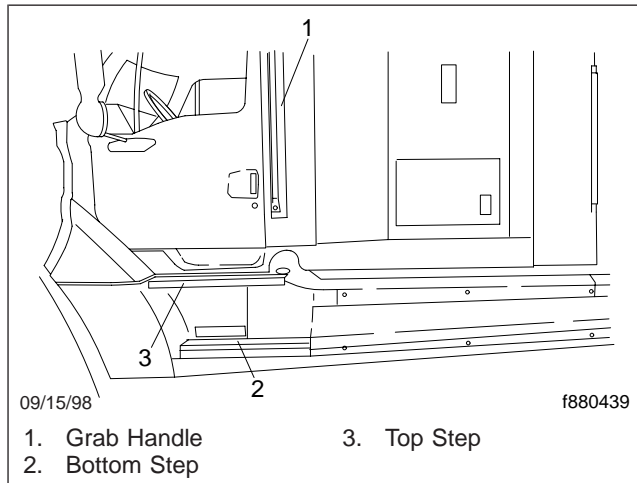
**Wet or dirty shoe soles greatly increase the chance of slipping or falling. If your soles are wet or dirty, be especially careful when climbing onto, or down from, the back-of-cab area.**

**Always maintain three-point contact with the back-of-cab access supports while entering and exiting the back-of-cab area. Three-point contact means both feet and one hand, or both hands and one foot, on the grab handles, steps, and deck plates. Other areas are not meant to support back-of-cab access, and grabbing or stepping in the wrong place could lead to a fall, and personal injury.**

**Be careful not to get hands or feet tangled in hoses or other back-of-cab equipment. Carelessness could cause a person to trip and fall, with possible injury.**

## Entering the Driver's Side (Left-Hand Drive) (Fig. 3.3)

When entering the cab from the driver's side, use the grab handle and access steps as follows:



**Fig. 3.3, Left-Side Steps and Grab Handle**

1. Open the driver's door, and place anything that you are carrying in the cab.
2. Grasp the grab handle with both hands. Reach up as far as is comfortable.
3. Place your right foot on the bottom step, and pull yourself up.
4. Place your left foot on the top step.
5. Grasp the steering wheel with your left hand, and step up.
6. Step into the cab with your right foot first, and grasp the steering wheel with your right hand.

## Exiting the Driver's Side (Left-Hand Drive) (Fig. 3.3)

Exit the cab from the driver's side as follows:

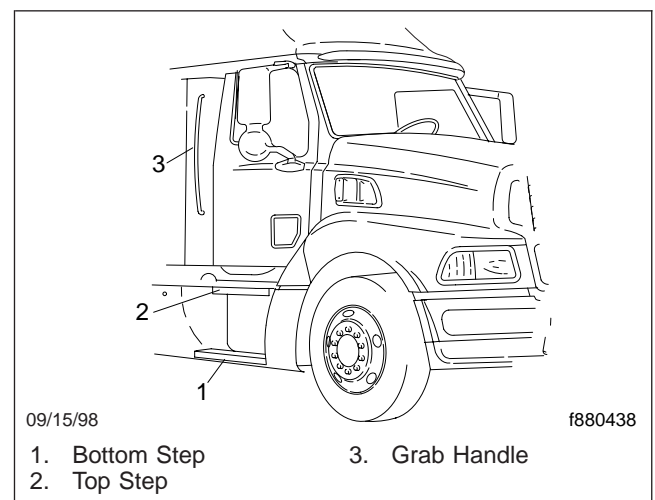
**IMPORTANT:** Do not attempt to exit the cab while carrying any items in your hands.

1. Grasp the steering wheel with both hands, place your left foot on the top step, and stand on the threshold, facing into the cab.
2. Grasp the grab handle at the rear edge of the door opening with your right hand.

3. Move your right foot to the bottom step.
4. Move your left hand to the grab handle.
5. Step to the ground with your left foot first.

## Entering the Passenger's Side (Left-Hand Drive) (Fig. 3.4)

When entering the cab from the passenger's side, use the grab handles and access steps as follows:



**Fig. 3.4, Right-Side Steps and Grab Handle**

1. Open the passenger's door, and place anything that you are carrying in the cab.
2. Grasp the grab handle at the rear edge of the door opening with your left hand.
3. Grasp the handle on the door with your right hand.
4. Place your right foot on the bottom step and step up to the upper step with your left foot.
5. Place your right foot on the top step and step up.
6. Step into the cab with your left foot first.

## Exiting the Passenger's Side (Left-Hand Drive) (Fig. 3.4)

Exit the cab from the passenger's side as follows:

**IMPORTANT:** Do not attempt to exit the cab while carrying any items in your hands.

# Vehicle Access

---

1. Place your right foot on the top step while standing up from the seat facing inward.
2. Place your left foot on the bottom step.
3. Move your left hand to the grab handle at the rear edge of the door opening.
4. Move your right hand to the grab handle on the door.
5. Step to the ground with your right foot first.

## Entering the Driver's Side (Right-Hand Drive) (Fig. 3.4)

When entering the cab from the driver's side, use the grab handle and access steps as follows:

1. Open the driver's door, and place anything that you are carrying in the cab.
2. Grasp the grab handle with both hands. Reach up as far as is comfortable.
3. Place your left foot on the bottom step, and pull yourself up.
4. Place your right foot on the top step.
5. Grasp the steering wheel with your right hand, and step up.
6. Step into the cab with your left foot first, and grasp the steering wheel with your left hand.

## Exiting the Driver's Side (Right-Hand Drive) (Fig. 3.4)

Exit the cab from the driver's side as follows:

**IMPORTANT:** Do not attempt to exit the cab while carrying any items in your hands.

1. Grasp the steering wheel with both hands, place your right foot on the top step, and stand on the threshold, facing into the cab.
2. Grasp the grab handle at the rear edge of the door opening with your left hand.
3. Move your left foot to the bottom step.
4. Move your right hand to the grab handle.
5. Step to the ground with your right foot first.

## Entering the Passenger's Side (Right-Hand Drive) (Fig. 3.3)

When entering the cab from the passenger's side, use the grab handles and access steps as follows:

1. Open the passenger's door, and place anything that you are carrying in the cab.
2. Grasp the grab handle at the rear edge of the door opening with your right hand.
3. Grasp the handle on the door with your left hand.
4. Place your left foot on the bottom step and step up to the upper step with your right foot.
5. Place your left foot on the top step and step up.
6. Step into the cab with your right foot first.

## Exiting the Passenger's Side (Right-Hand Drive) (Fig. 3.3)

Exit the cab from the passenger's side as follows:

**IMPORTANT:** Do not attempt to exit the cab while carrying any items in your hands.

1. Place your left foot on the top step while standing up from the seat facing inward.
2. Place your right foot on the bottom step.
3. Move your right hand to the grab handle at the rear edge of the door opening.
4. Move your left hand to the grab handle on the door.
5. Step to the ground with your left foot first.

## Door Windows

The windows in both doors operate electrically (if so equipped). Use the appropriate switch to raise or lower a door window.

## Sleeper Compartment Vents

To open any sleeper compartment vent, push the vent handle outward and forward with your fingertips. To close the vent, turn your hand so that your fingers are pulling on the handle from the front edge, then pull in and back on the handle. Use care to avoid pinching your fingers.

## Power Distribution Module and Power Distribution Box

The power distribution module (Fig. 3.5) is located behind the power distribution module cover on the passenger side of the instrument panel. To gain access to the module, loosen the four quarter-turn fasteners on the cover. Depending on vehicle options, fuse/relay/circuit breaker locations may vary from those shown. Refer to Fig. 3.5 or Table 3.1 for fuse/relay/circuit breaker identification information.

A power distribution box (Fig. 3.6) is located in the engine compartment. To gain access to the box, open the cover. Depending on vehicle options, fuse/relay/circuit breaker locations may vary from those shown. Refer to Fig. 3.6 or Table 3.2 for fuse/relay/circuit breaker identification information.

Power Distribution Module Identification		
Position	Description	Rating
<b>Circuit Breakers</b>		
1	Left Power Window	18A*
2	Power Door Locks	10A
3	Right Power Window	18A*
4	Power Mirrors	10A
5	Windshield Wiper/Washer	11A*
6	Open	—
7	Ignition Switch	10A
8	Fuel Shutoff Relay	10A
9	Open	—
10	Reverse Lamps	10A
11	Stop Lamps	10A
12	Open	—
13	Flasher Unit	10A
14	Horn	10A
15	Ignition Connection Antilock Brakes	5A
16	Open	—
17	Customer-Constant 12V	10A
18	Customer-Accessory	10A
19	A/C-Blend Motor, Blower Relay	5A
20	Cigar Lighter	10A
21	Mirror Heater	10A
22	Switch-Trailer Auxiliary, Customer	5A
23	Open	—
24	Open	—
25	Air Intake Heater Module	10A
26	Engine/Exhaust Brake	10A
27	Warning Lamps	5A

Power Distribution Module Identification		
Position	Description	Rating
28	Fan Clutch Solenoid, A/C Pressure Switch	5A
29	Aircon Compressor	10A
30	Air Switches	5A
31	Clock Connection-Constant 12V	5A
32	Dash Display, Diagnostic Connection 12V	5A
33	Gauges	5A
34	Clock, Road Speed Module-Ignition	5A
35	Cruise Switch, Diagnostic Connection-Ignition	5A
36	Open	—
37	Headlamp Switch	10A
38	Flash-to-Pass Switch	5A
39	Courtesy Lamps	10A
40	Low Beam Relay Control	5A
41	Park Relay Control	5A
42	Fog Lamps Switch	5A
43	Radio-Cassette-Constant 12V	5A
44	Audio Connector-Constant 12V	5A
45	Radio-Cassette-Accessory	5A
46	Audio Connector-Accessory	5A
47	Stud Module A-Constant 12V	10A
48	Stud Module C-Constant 12V	10A
49	High Beam Relay Control	5A
50	Road Lamp Switch, High Beam Indicator Lamp	5A
51	Park Lamps-Front and Rear	10A
52	Park Lamps-Roof and Mirror	10A
53	Park-Radio/Cassette, Dash Display	5A
54	Dimmer-Instrument Panel	10A
<b>Relays</b>		
R1	Left Power Window	—
R2	Right Power Window	—
R3	Horn	—
R4	Ignition CB25 to CB30	—
R5	Accessory CB19 to CB24	—
R6	Ignition-Stop, Reverse, CB12	—
R7	Interior Illumination	—
R8	Blower Motor	—
R9	Flasher	—
R10	Accessory-Customer	—
R11	Windshield Wiper/Washer-Accessory	—
R12	Fuel Shutoff	—
R13	Audio-Accessory	—

# Vehicle Access

Power Distribution Module Identification		
Position	Description	Rating
R14	Gauges/Electronics-Ignition	—
R15	Engine Control Module-Ignition	—
R16	Exterior Park Lamps	—
R17	Open	—
R18	Open	—
Stud Module		
A	Constant (CB 47)	12V
B	Ground	—
C	Constant (CB 48)	12V
D	Open	—
E	Open	—
F	Open	—
G	Open	—

\* Cycling Type (Automatic Reset)

**Table 3.1, Power Distribution Module Identification**

Power Distribution Box Identification		
Position	Description	Rating
Relays		
R1	Trailer Reverse Lamps	—
R2	Trailer Stop Lamps	—
R3	Trailer Left Turn	—
R4	Trailer Right Turn	—
R5	Trailer Park and Marker Lamps	—
R6	Trailer Auxiliary	—
R7	Open	—
R8	Open	—
R9	Open	—
R10	Open	—
R11	Open	—
R12	Open	—
R13	Aircon Pressure Switch	—
R14	Fog Lamps (Drive Option)	—
R15	High-Beam Headlamps	—
R16	Low-Beam Headlamps	—
R17	Road (Drive) Lamps	—
R18	Open	—
Circuit Breakers		
1	Open	—
2	Open	—
3	Open	—
4	Open	—
5	Cab-Power-Window Right, Mirrors	20A
6	Trailer Reverse Lamps	30A*

Power Distribution Box Identification		
Position	Description	Rating
7	Trailer Stop Lamps	30A*
8	Trailer Left Turn	30A*
9	Trailer Right Turn	30A*
10	Trailer Park and Marker Lamps	30A*
11	Cab-Stud Module	20A
12	Cab-Windshield Wiper, F6	20A
13	Cab-Stop, Reverse, F12	20A
14	Cab-Accessory Relay	20A
15	Cab-Park Lamps-Exterior	20A
16	Open	—
17	Open	—
18	Open	—
19	Open	—
20	Cab-Power-Window Left, Door Locks	20A
21	Fog Lamps (Drive Option)	20A*
22	High-Beam Headlamps	20A*
23	Low-Beam Headlamps	20A*
24	Road (Drive) Lamps	20A*
25	Trailer Auxiliary	20A*
26	Cab-Customer Access	20A
27	Cab-Lighting Control, Courtesy	20A
28	Cab-Heater Aircon Blower Motor	30A Maxifuse
29	Cab-Flasher Unit, Horn	20A
30	Cab-Ignition Switch, Relay, Fuel Shutoff	20A

\* Cycling Type (Automatic Reset)

**Table 3.2, Power Distribution Box Identification**

## Cab-to-Sleeper Access



**Place rigid or heavy objects in storage areas on the floor or under the bunk. Sudden stops or swerves could cause personal injury if items fall from overhead storage shelves.**

To open the sleeper access on vehicles with vinyl sleeper curtains, unzip the sleeper curtains. If desired, unsnap the curtains all the way around the sides and top and remove the curtains.

To open the sleeper access on vehicles with velour sleeper curtains, unfasten the snaps at one side, then push the curtain to the opposite side.

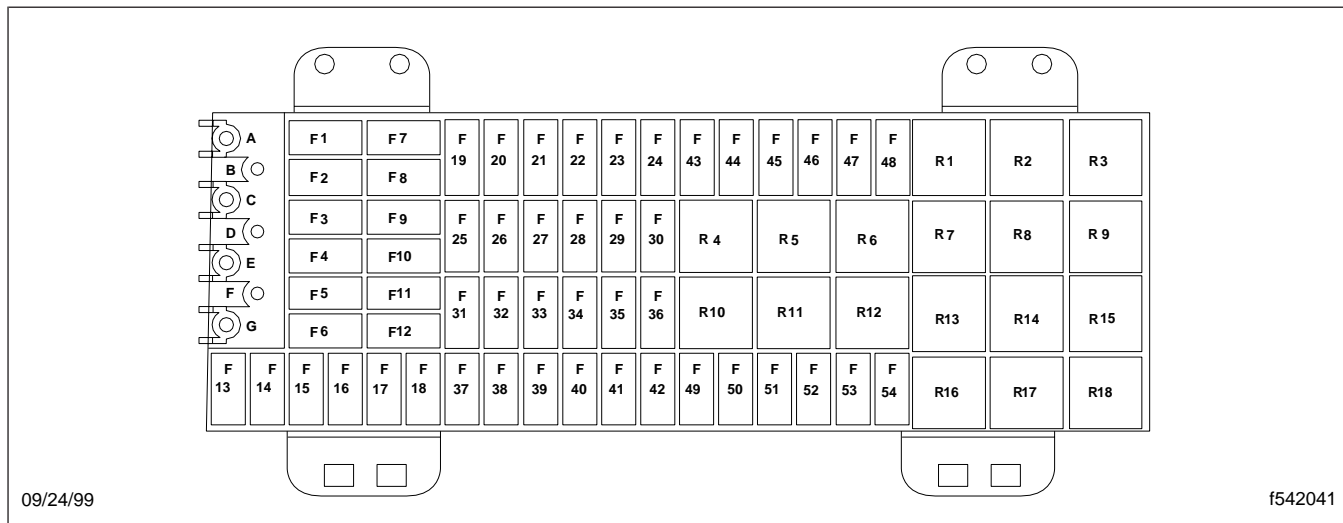


Fig. 3.5, Power Distribution Module

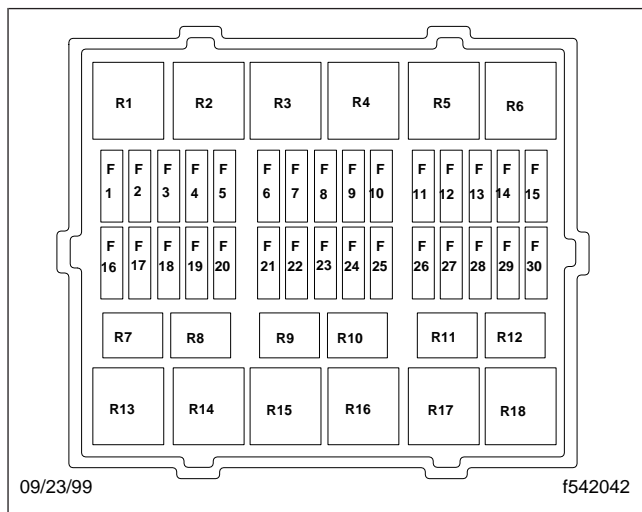


Fig. 3.6, Power Distribution Box

## Sleeper Bunk Latches

To move the lower or upper sleeper bunk (if equipped), disengage the latch at the front of the lower bunk, or the latches on both sides of the upper bunk. Lock the bunks into operating position, down for the lower bunk and up or down for the upper bunk, by engaging both the primary and secondary latches.

## Sleeper Compartment Exit Door

The sleeper compartment exit door (Fig. 3.7) is intended for use as an emergency exit only. The door can not be opened from outside the sleeper.

To open the door from the inside, push down on the lever handle located inside the sleeper compartment to the right of the door. To close the door, push it closed until it latches.

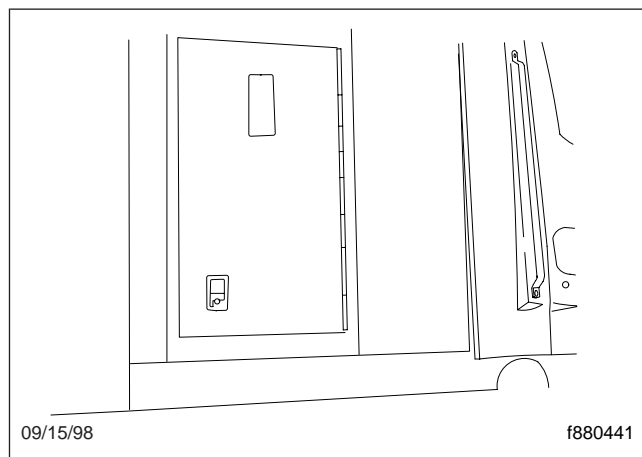


Fig. 3.7, Sleeper Exit Door

# Vehicle Access

## Baggage Compartment Doors

To unlock the baggage compartment door on the right side, insert the ignition key in the lockset, and turn it one-quarter turn clockwise. Turn the key to the original position to remove it. Pull up and outward on the baggage door handle to open the door. To close the door, push it closed until it latches. To lock the door, insert the ignition key in the lockset and turn it one-quarter turn counterclockwise.

Use the same procedure to open the baggage compartment door on the left side, but turn the key counterclockwise to unlock the door and clockwise to lock it.

## Back-of-Cab Grab Handles, Steps, and Deck Plate

When trailer air and electrical connections cannot be coupled from the ground, steps and grab handles are configured to facilitate safe back-of-cab access; see [Fig. 3.8](#).

### **WARNING**

Follow these rules for back-of-cab access. Failing to follow these rules could lead to a fall, and possible personal injury.

Never step on any exterior part unless it has a slip-resistant surface meant for safe stepping. If the surface is movable, such as a battery box cover with a slip-resistant surface, be certain it is firmly secured.

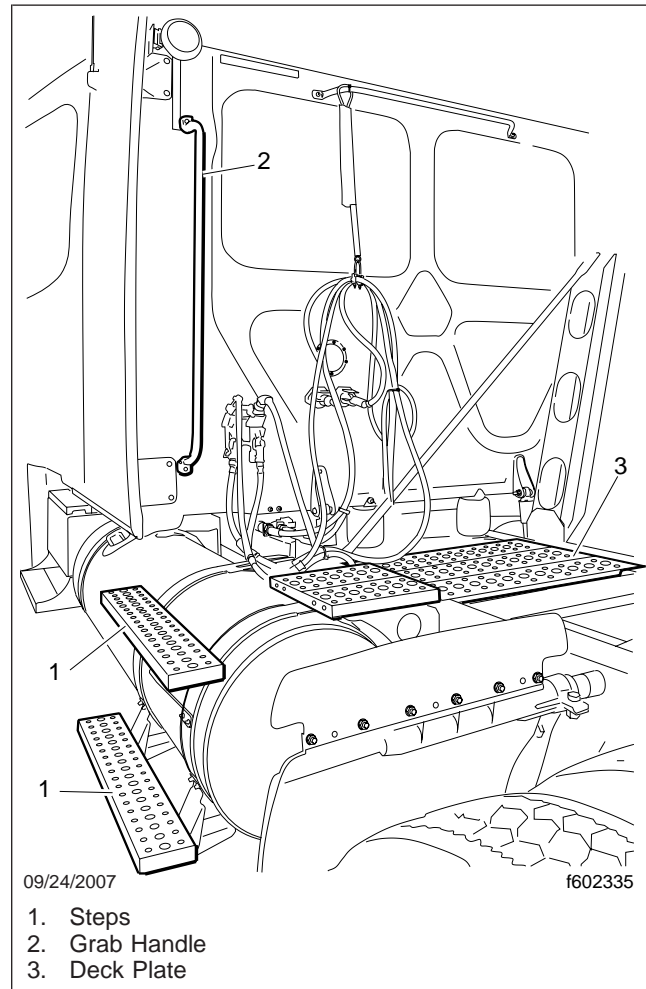
Be careful not to trip on items such as chains or air lines in the back-of-cab area.

Always follow safety procedures for back-of-cab access, maintaining three-point contact—both hands and one foot, or both feet and one hand—whenever moving around, and always face in toward the deck plate when climbing up or down.

Wet or dirty shoes, steps, or grab rails greatly increase the chance of slipping or falling. If your shoes or the contact areas are wet or dirty, clean and dry them as much as possible before accessing the back of cab area, and be especially careful when climbing or standing on the vehicle.

**Never jump onto, or off of, a vehicle; doing so creates a very high likelihood of a fall and personal injury.**

A grab handle and steps facilitate safe climbing up or down.



**Fig. 3.8, Back-of-Cab Access**

## Accessing Back-of-Cab Area

When climbing onto the deck plate, use the grab handle and access steps as follows:

1. Facing the center of the deck plate, grasp the grab handle with both hands. Reach up as far as is comfortable.
2. Place one foot on the bottom step, and pull yourself up.

3. Place your other foot on the top step.
4. Move your lower hand to a higher position on the grab handle.
5. Step onto the deck plate.

## Exiting the Back-of-Cab Area

When climbing down from the deck plate, use the grab handle and access steps as follows:

1. Facing the center of the deck plate, grasp the grab handle with both hands.
2. Step one foot at a time to the top step.
3. Move your upper hand to a lower position on the grab handle.
4. Move one foot to the bottom step.
5. Move your upper hand to a lower position on the grab handle.
6. Step to the ground with your upper foot first.

## Battery Box Cover

If equipped, remove the valance in front of the frame rail-mounted battery box. For instructions, refer to **Group 60** in the *Sterling L-Line and A-Line Workshop Manual*. If necessary, remove the step. To remove the cover from the frame rail-mounted battery box, release the latches. Pull on the end of each hold-down latch until the end clears the cover-mounted catch. Pivot the latches out of the way, then lift off the cover. When installing the cover, be sure it is positioned properly before fastening the latches.

To remove the cover from the battery box mounted between the frame rails, remove the deck plate and lift the handle on the top of the battery box cover. If equipped, remove the spring pin.

## Hood Tilting

The hood can be tilted to a full-open position. A grab handle at the front of the hood provides a handhold for hood tilting. A torsion bar helps you to tilt the hood open, and to return it to the operating position. Hood straps prevent the hood from over-travel. In the operating position, the hood is secured to the lower cab side panels by a hold-down latch on each side of the hood.

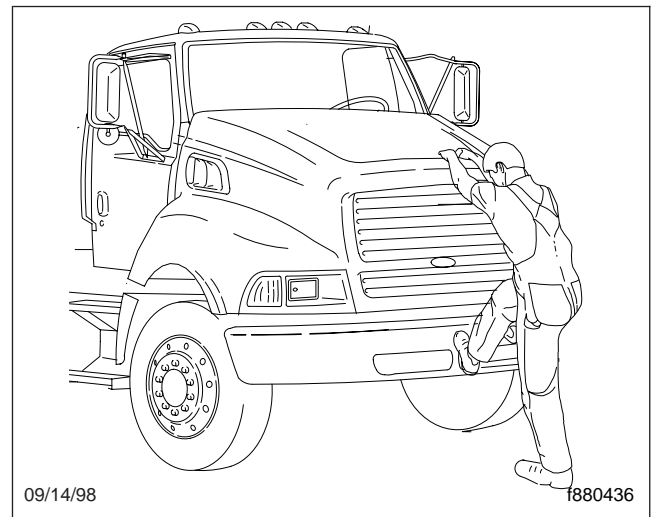
## To Tilt the Hood

1. Apply the parking brakes.
2. Release both hood hold-down latches by pulling the ends outward.

### CAUTION

**Do not let the hood free-fall to the full-open position. To do so could cause damage to the hood or hood straps.**

3. Using the bumper step and grab handle, slowly tilt the hood until the straps support it. See [Fig. 3.9](#).



**Fig. 3.9, Hood Tilting**

## To Return the Hood

1. Grasp the grab handle, and lift the hood to the 45 degree position.
2. As the hood goes over center, use the bumper step and grab handle to control the rate of descent to the operating position.
3. Make sure the hood is flush with the cowl, then secure the hood by engaging both hood hold-down latches.

**IMPORTANT:** Make sure that both hold-down latches are fully engaged before operating the vehicle.



# 4

## Heater and Air Conditioner

---

HVAC General Information .....	4.1
Defogging and Defrosting Using Fresh Air .....	4.1
Heating .....	4.2
Air Conditioning .....	4.2
Fresh Air .....	4.2
Heating, Auxiliary (Sleeper Bunk) Heater and Air Conditioner .....	4.2
Air Conditioning, Auxiliary (Sleeper Bunk) Heater and Air Conditioner .....	4.3

# Heater and Air Conditioner

## HVAC General Information

A dash-mounted climate control panel (Fig. 4.1 or Fig. 4.2) allows you to control all of the heating, air conditioning, defrosting, and ventilating functions.

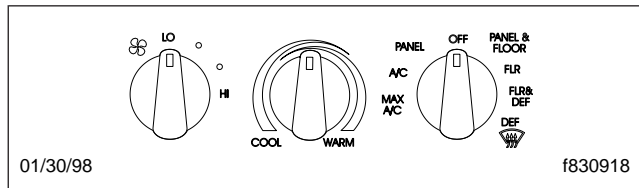


Fig. 4.1, Climate Control Panel, Heater and Air Conditioning

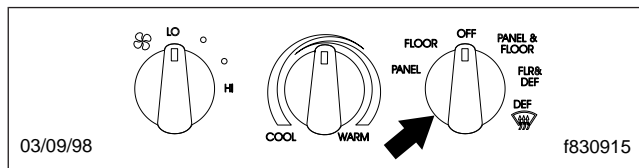


Fig. 4.2, Climate Control Panel, Heater Only

A four-speed fan forces fresh or recirculated air to any selected air outlets at the windshield, door windows, instrument panel, and cab floor. An air selection switch controls the direction of warm or cool air either through the instrument panel registers, the panel registers and floor outlets, the floor outlets, the floor and defrost (windshield) outlets, or the defrost outlets.

Fresh air is forced through the air outlets when the air selection switch is in the A/C, PANEL, PANEL & FLOOR, FLR, FLR & DEF, and DEF positions. Recirculated air is forced through the air outlets when the air selection switch is in the MAX A/C position. Dusty or smoky outside air is prevented from being drawn inside the cab when the air selection switch is in the OFF position.

A temperature control switch is used to select the desired temperature. Turn the switch counterclockwise for cool air, or clockwise for warm air.

An auxiliary heater and air conditioner unit is standard when there is a sleeper compartment. The unit is installed in the right-side sleeper baggage compartment and uses the cab's refrigerant system for air conditioner operation. The unit is equipped with a separate evaporator coil, expansion valve, and fan. It is also equipped with a heater core that is independent of the cab heater. The auxiliary unit's climate

control panel (Fig. 4.3) is mounted on the right rear wall, or the rear overhead storage compartment.

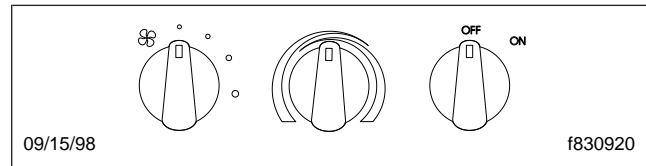


Fig. 4.3, Auxiliary (sleeper bunk) Control Panel

NOTE: Shutting off the heater supply gate valve (if equipped) on the engine limits the ability to control air conditioning temperature in the cab and in the sleeper. With the valve shut off, warm coolant is no longer available from the engine, and the outlet air temperature controls can't be used to change air temperature.

IMPORTANT: To prevent the buildup of fumes or odors inside the cab (for example, from smoking), *do not* operate the air conditioning system in the MAX A/C mode for more than 20 minutes.

## Defogging and Defrosting Using Fresh Air

1. Turn the temperature control switch all the way clockwise for warm air, the fan switch to LO and, if so equipped, the bunk fan switch to OFF before starting the engine.
2. Remove any ice or snow from the outside of the windshield, door windows, and fresh air inlet grille.
3. With the engine at operating temperature, turn the fan switch to the highest speed. Leave it in this position for 30 seconds. This will clear the system of moist air.
4. Move the air selection switch to the defrost (windshield) position. In this position warm, dry air is directed to the windshield.

NOTE: The air conditioner (if equipped) is automatically engaged in the defrost mode. This dries the air.

## Heating

1. With the engine at operating temperature, move the temperature control switch all the way clockwise (for heat).
2. Turn on the fan switch to the desired speed.
3. Move the air selection switch to the desired setting.

**IMPORTANT:** If the windows start to fog, move the air selection switch to defrost (windshield) and make sure the fan is on.

**NOTE:** In mild weather the fan switch can be kept in the LO position since forward motion of the vehicle will provide airflow through the heater.

4. If the vehicle has a sleeper with a rear climate control panel, set the controls as desired; refer to "Heating, Auxiliary Heater and Air Conditioner."
5. When a comfortable temperature has been reached, adjust the fan switch setting and temperature control as needed to maintain the temperature.

## Air Conditioning

**IMPORTANT:** Operate the air conditioner at least five minutes each month, even during cool weather. This helps prevent drying and cracking of tubing seals, reducing refrigerant leaks in the system. Operate the air conditioner only after the engine compartment is warm, and the interior of the cab is 70°F (21°C) or higher. During cold weather, the heater can be operated at the same time, to prevent discomfort.

1. If the cab is hot inside, temporarily open the windows to let the hot air out.
2. Move the air selection switch to the (non-air conditioning) panel position and turn the fan switch to LO before starting the engine.
3. Start the engine.
4. Move the air selection switch to either one of the air conditioning settings. With the switch at the A/C setting, fresh air is drawn into the cab. With the switch at MAX A/C, the air inside the cab is recirculated.

**IMPORTANT:** If the outside air is dusty or smoky, set the air selection switch at maximum air conditioning and keep the windows and vent closed to prevent drawing in dust or smoke. The air selection switch can also be set to OFF to prevent drawing in dust or smoke.

5. Move the temperature control switch counterclockwise for cool air. In this position, no heat is given off by the heater.
6. Turn the fan switch to the highest speed.
7. As soon as cool air is flowing from the instrument panel registers, close the windows. Adjust the fan switch setting as desired.
8. If the air from the vents is too cold, move the temperature control switch clockwise for warmer air flow.

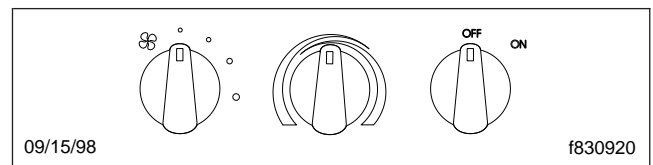
**IMPORTANT:** To prevent the buildup of fumes or odors inside the cab (for example, from smoking), *do not* operate the air conditioning system in the MAX A/C mode for more than 20 minutes.

## Fresh Air

1. Move the air selection switch to the desired position.
2. Move the temperature control switch counterclockwise for no heating, or move it clockwise for heat.
3. Set the fan switch at the desired speed.

## Heating, Auxiliary (Sleeper Bunk) Heater and Air Conditioner

1. With the engine at operating temperature, set the air selection switch on the main climate control panel to the floor or panel position.
2. Turn the on/off control knob to On. See [Fig. 4.4](#).



**Fig. 4.4, Auxiliary (sleeper bunk) Control Panel**

# Heater and Air Conditioner

---

3. Turn the temperature control knob all the way clockwise to HEAT. Turn the fan control knob to the highest position.
4. When the sleeper compartment heats to the desired temperature, turn the temperature control knob counterclockwise to adjust outlet air temperature. Then, turn the fan control knob to adjust the air flow level.

The system will maintain the selected outlet air temperature.

5. Whenever heat is not desired, turn the temperature control knob counterclockwise (as needed) and turn off the fan.

**IMPORTANT:** To prevent the buildup of fumes or odors inside the sleeper (for example, from smoking) *do not* operate the air conditioning system in the MAX A/C mode for more than 20 minutes.

## Air Conditioning, Auxiliary (Sleeper Bunk) Heater and Air Conditioner

1. Turn on the cab air conditioner (refer to "Air Conditioning").
2. Turn the on/off control knob to On. See [Fig. 4.4](#).
3. Turn the temperature control knob all the way counterclockwise to COOL. Turn the fan control knob to the highest position.
4. When the sleeper compartment cools to the desired temperature, turn the temperature control knob clockwise to adjust outlet air temperature. Then, turn the fan control knob to adjust the air flow level.

The system will maintain the selected outlet air temperature.

5. Whenever air conditioning is not desired, turn the temperature control knob clockwise (as needed) and turn off the fan.

**IMPORTANT:** To prevent the buildup of fumes or odors inside the sleeper (for example, from smoking) *do not* operate the air conditioning system in the MAX A/C mode for more than 20 minutes.

# 5

## Seats and Seat Belts

---

Seats .....	5.1
Seat Belts and Tether Belts .....	5.5
Sleeper Compartment Bunk Restraints .....	5.7

# Seats and Seat Belts

## Seats

### General Information

Unless otherwise noted, all seat adjustments should be made while seated and before the engine is started.

#### **WARNING**

Keep hands, tools, and other objects away from the scissor points under the seats. Failure to do so could cause personal injury.

### Seat Adjustment

The following is a description of adjustments that can be made to various Sterling-installed seats. Not all seats have all of the adjustments listed below. See [Fig. 5.1](#).

1. Back Cushion Tilt: This adjustment enables the back cushion to pivot forward or backward.
2. Lumbar Support: Lumbar support changes the shape of the seat-back to give more or less support to the occupant's lumbar (lower back) area. This adjustment is either mechanical or air controlled, depending on make and model of seat.
3. Isolator: This feature (also referred to as back-slap isolator or Chugger-Snubber<sup>®</sup>) reduces the amount of road shock by isolating the occupant from the motion of the vehicle, and allowing the upper seat to move in a simple pendulum motion. A lockout feature is used whenever the isolator is not desired.
4. Height Adjustment: The entire seat moves up or down when adjusting the height. The adjustment is either manually or air controlled, depending on the make of the seat.
5. Bottom Cushion Angle or Fore and Aft Bottom Cushion Height: This feature enables the occupant to raise or lower the front or back of the bottom cushion. This adjustment is easier to perform when all weight is removed from the seat.

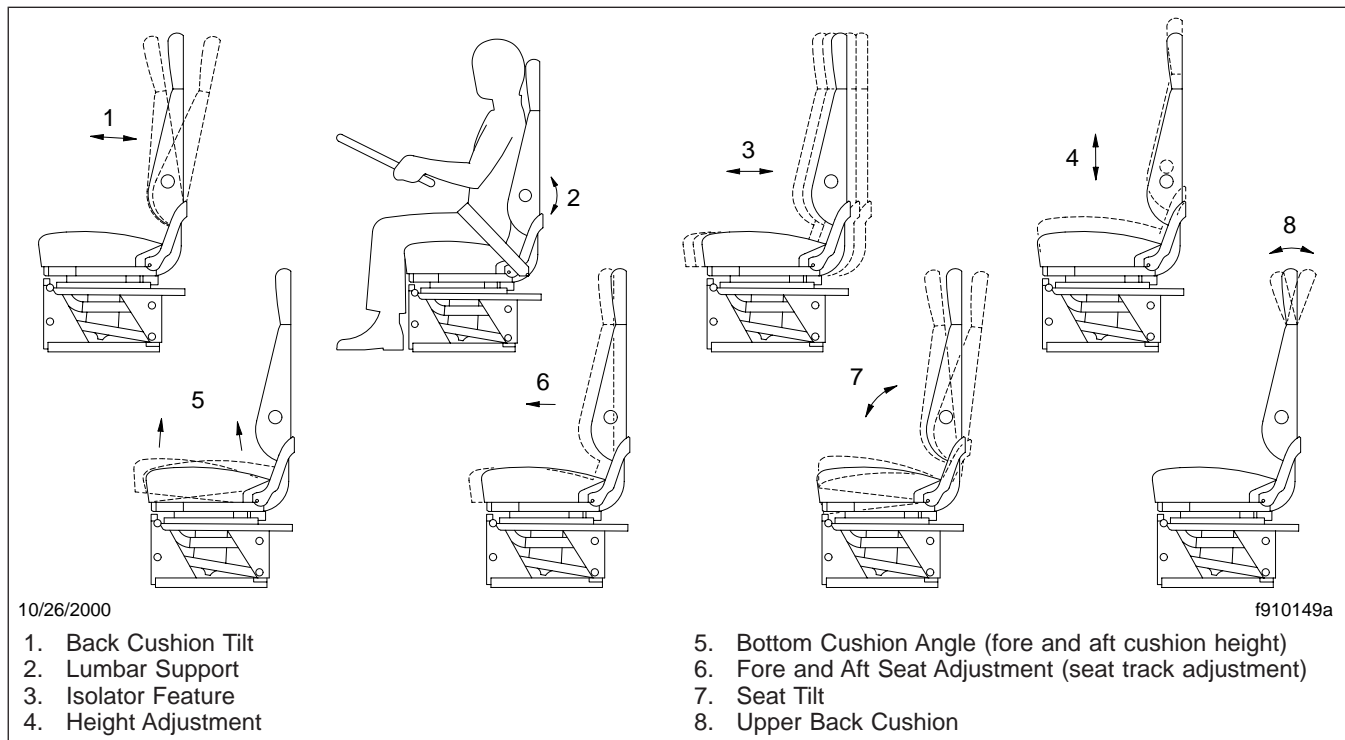


Fig. 5.1, Seat Adjustments

6. Fore and Aft Seat or Seat Track Adjustment: The entire seat moves forward or backward when this adjustment is made.
7. Seat Tilt: When this adjustment is made, the seat assembly (back and bottom cushions) tilts forward or backward.
8. Upper Back Cushion Adjustment: When this adjustment is made, the angle of the upper back cushion changes to provide upper back support.
9. Weight Adjustment: On those seats with weight adjustment, the feature is fully automatic. When you sit on the seat, a leveling valve places you in the center of the ride zone. Additional adjustments are possible by using the height adjustment feature.

## EzyRider® Seat

For seat adjustment controls on vehicles built before November 28, 2005, see [Fig. 5.2](#). For seat adjustment controls on vehicles built on or after November 28, 2005, see [Fig. 5.3](#).

### Back Cushion Tilt

To tilt the back cushion, raise the back cushion tilt lever and lean forward or backward. Release the lever to lock the cushion in place.

### Lumbar Support

To adjust the amount of support for your lower back, use the lumbar support switch or lever on the side of the seat.

### Isolator

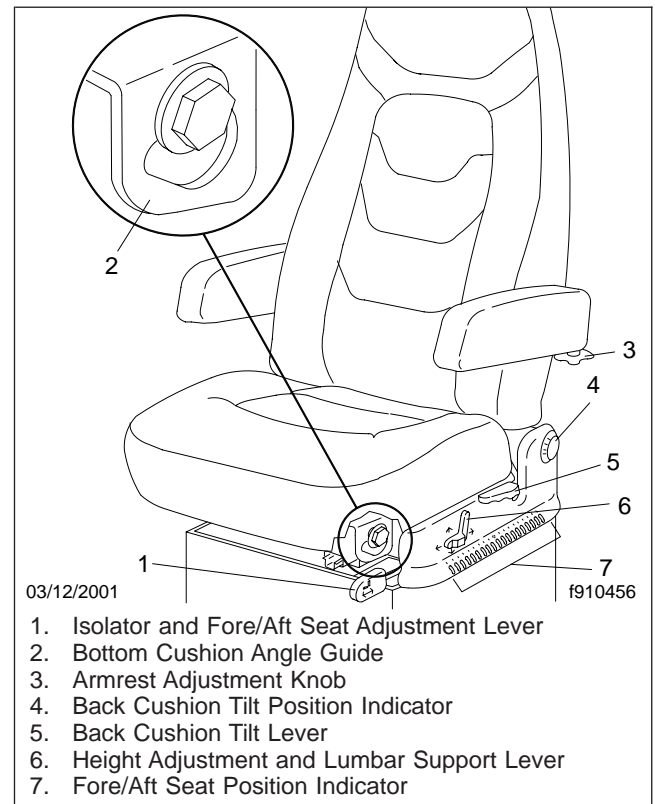
To engage the isolator, push in on the isolator lever. To lock out the isolator, pull the isolator lever out to the first stop.

### Fore and Aft Seat Adjustment

Pull the fore and aft seat adjustment lever out to the second stop and slide the seat forward or backward to the desired position.

### Height Adjustment

To raise or lower the seat, use the height adjustment switch or lever on the side of the seat.



**Fig. 5.2, EzyRider Seat Adjustment Controls (Vehicles Built Before November 28, 2005)**

### Bottom Cushion Angle

To adjust the bottom cushion angle, pull the bottom cushion up and forward or down and back. The bottom cushion angle is controlled by the guides on each side of the seat.

### Seat Position Indicators

Seats installed in vehicles built before November 28, 2005 are equipped with seat position indicators. A back cushion tilt position indicator and a fore/aft seat position indicator allow the driver to see where the seat is adjusted within the adjustment ranges.

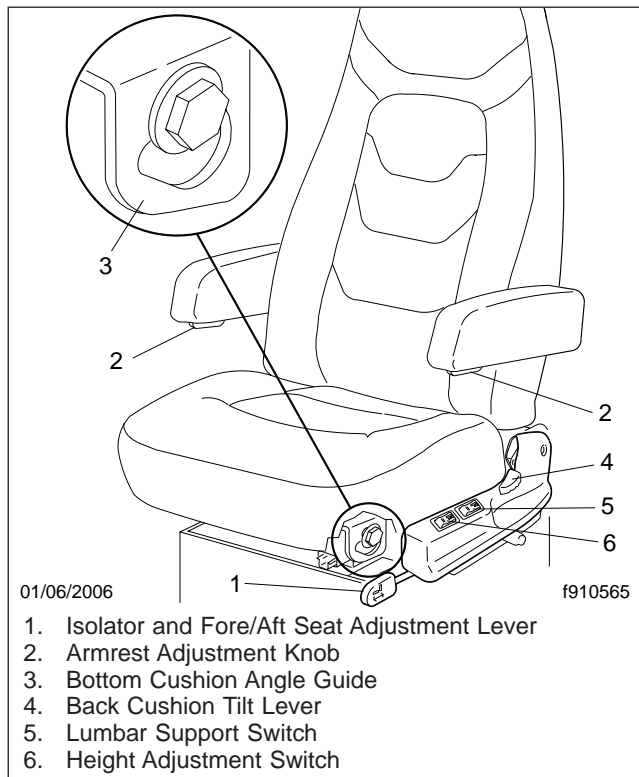
### Armrest Angle (optional armrests)

To adjust the vertical angle of the armrest, turn the adjustment knob on the underside of the armrest.

## Bostrom Talladega™ 915 Seat

See [Fig. 5.4](#) for seat adjustment controls.

# Seats and Seat Belts



**Fig. 5.3, EzyRider Seat Adjustment Controls (Vehicles Built on or After November 28, 2005)**

## Back Cushion Tilt

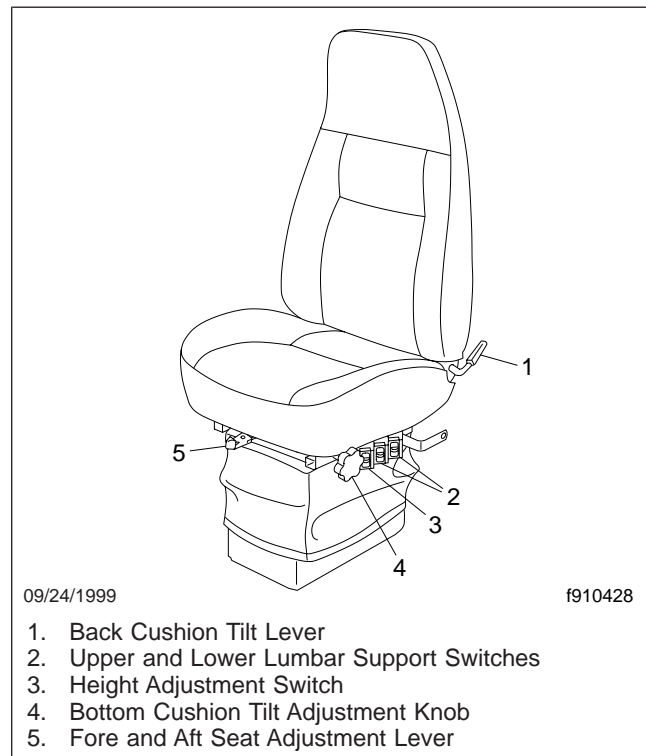
To tilt the back cushion, lean forward slightly to remove pressure from the cushion and hold the back cushion tilt lever down. Lean backward slowly to the desired position and release the lever to lock the cushion in place.

## Height Adjustment

To raise the seat, push up on the height adjustment switch. To lower the seat, push down on the height adjustment switch.

## Fore and Aft Seat Adjustment

Move the fore and aft seat adjustment lever to the side to adjust the seat to the desired fore-aft position. Move the lever back to its original position to lock the fore-aft position.



**Fig. 5.4, Bostrom Talladega 915 Seat Adjustment Controls**

## Bottom Cushion Tilt Adjustment

Turn the bottom cushion tilt adjustment knob to increase or decrease the bottom cushion tilt.

## Lumbar Support

For seats with air lumbar support, use the upper and lower lumbar support switches to adjust the top lumbar and bottom lumbar supports.

## National 2000 Series Seat

See [Fig. 5.5](#) for seat adjustment controls.

## Back Cushion Tilt

To tilt the back cushion, turn the back cushion tilt knob until the desired position is reached.

## Height Adjustment

To raise or lower the height of the seat, use the height adjustment switch on the side of the seat.



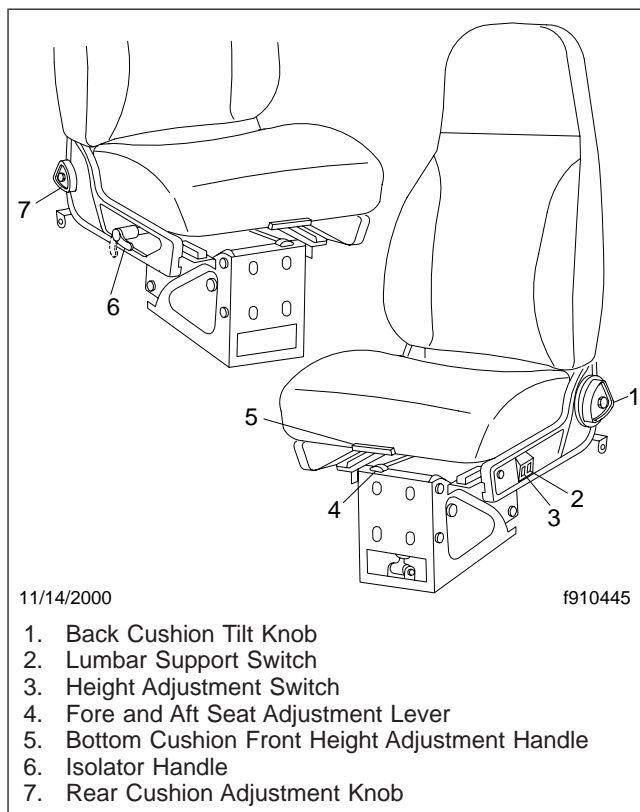


Fig. 5.5, National 2000 Series Seat Adjustment Controls

## Fore and Aft Seat Adjustment

To adjust the fore and aft position of the entire seat, move the fore and aft seat adjustment lever to the left and slide the seat forward or backward to the desired position. Move the lever back to its original position to lock the seat in place.

## Rear Cushion Adjustment

To adjust the height of the rear of the seat cushion, remove your weight from the seat and turn the rear cushion adjustment knob to one of three positions.

## Isolator

Also called a Chugger Snubber®, the isolator reduces the amount of road shock by isolating the occupant from the motion of the vehicle and allowing the seat to move in a simple pendulum motion. To use the isolator feature, turn the isolator handle to the horizontal position. Turn the isolator handle down when the isolator feature is not desired.

## Lumbar Support

To adjust the lumbar support, use the lumbar support switch on the side of the seat to give more or less support to your lower back.

## Bottom Cushion Front Height

To adjust the height of the front of the bottom cushion, lift the bottom cushion front height adjustment handle, and pull forward or push back to the desired setting.

## National Nonsuspended Seat

See Fig. 5.6 for seat adjustment controls.

## Back Cushion Tilt

To tilt the back cushion, turn the back cushion tilt knob and lean forward or backward.

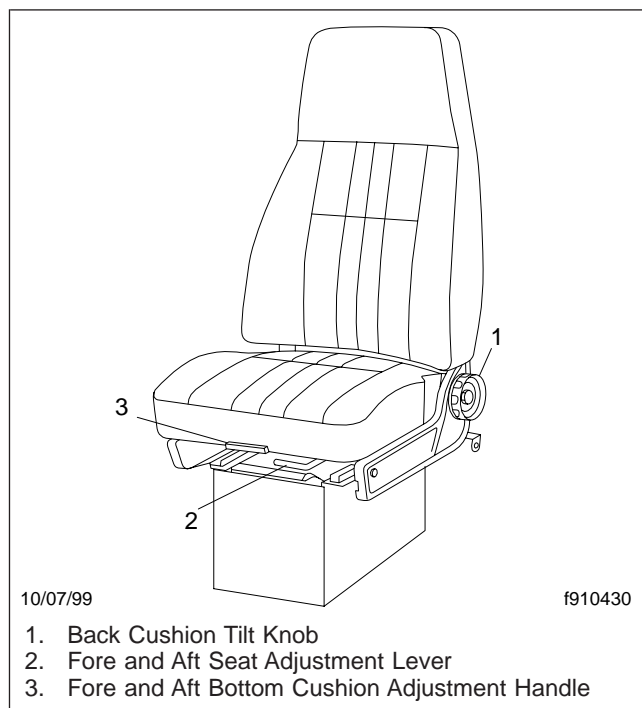


Fig. 5.6, National Nonsuspended Seat Adjustment Controls

## Fore and Aft Seat Adjustment

To adjust the fore and aft position of the entire seat, move the fore and aft seat adjustment lever to the

# Seats and Seat Belts

left and slide the seat forward or backward to the desired position.

## Fore and Aft Bottom Cushion Adjustment

To adjust the fore and aft position of the bottom cushion only, pull the fore and aft bottom cushion adjustment handle out and slide the bottom cushion forward or backward to the desired position.

## Two-Passenger Bench Seat

The two-passenger bench seat (Fig. 5.7) is stationary. The bottom seat cushion lifts up for an additional storage area.

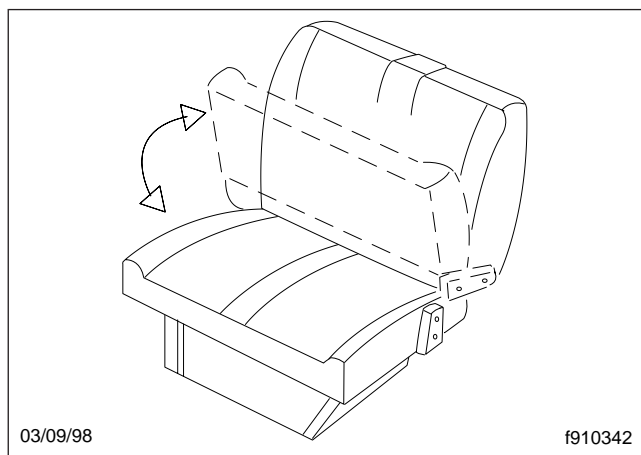


Fig. 5.7, Two-Passenger Bench Seat

## Seat Belts and Tether Belts

### General Information

Seat belt assemblies are designed to secure persons in the vehicle to help lessen the chance of injury or the amount of injury resulting from accidents or sudden stops. For this reason, Sterling Truck Corporation urges that the driver and *all* passengers, regardless of age or physical condition, use seat belts when riding in the vehicle.

Seat belt assemblies in the vehicle meet Federal Motor Vehicle Safety Standard 209, "Type 1" and "Type 2" requirements. They are recommended for all persons weighing over 50 pounds (23 kg).

A child restraint system should also be provided for each child weighing 50 pounds (23 kg) or less. It should meet the requirements of Federal Motor Vehicle Safety Standard 213, "Child Restraint Systems."

When providing such a restraint system, carefully read and follow all instructions pertaining to installation and usage for the child. Make certain the child remains in the restraint system at all times when the vehicle is in motion.

In addition to seat belt assemblies, tether belts are installed on suspension-type seats. Tether belts help secure the seat to the floor and are intended to restrain the seat and seat belt in case of an accident or sudden stop.

**IMPORTANT:** Seat belts have a finite life which may be much shorter than the life of the vehicle. Regular inspections and replacement as needed are the only assurance of adequate seat belt security over the life of the vehicle.

See **Chapter 11** for the seat belt inspection procedure.

### Seat Belt Operation

#### Three-Point Seat Belt With Komfort® Latch

While your vehicle is in motion, the combination lap and shoulder belt adjusts to your movement. However, if you brake hard, corner hard or if your vehicle receives an impact of 5 mph (8 km/h) or more, the lap and shoulder belt locks and prevents you from moving.

### WARNING

**Wear three-point seat belts only as described below. In case of an accident or sudden stop, injuries could result from misuse. Three-point seat belts are designed to be worn by one person at a time.**

### WARNING

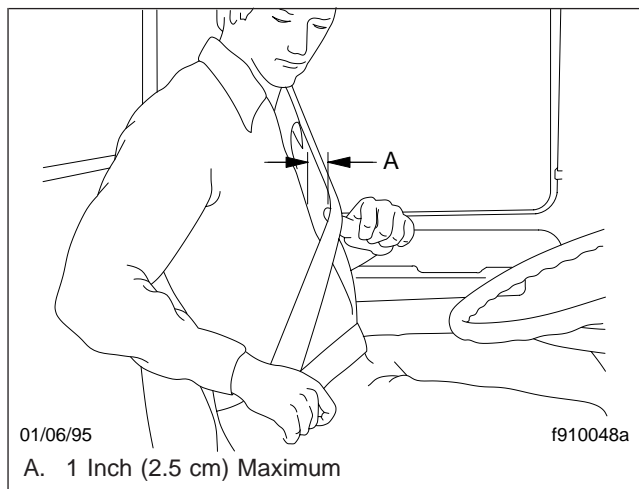
**Fasten the seat belts before driving. Fastening a three-point seat belt while driving creates a hazard.**

1. Pull the lap-shoulder portion of the belt from the retractor so that the shoulder portion of the belt crosses your shoulder and chest. Insert the belt tongue into the proper buckle until you hear a snap and feel it latch.

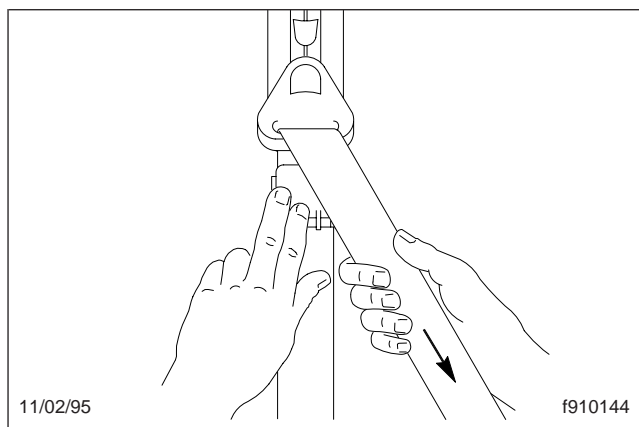
# Seats and Seat Belts

2. Tighten the lap portion of the belt, pull up on the shoulder piece until it fits you snugly. The belt should rest as low on your hips as possible.
3. If desired, engage the Komfort® latch as follows:

Pull on the shoulder strap to lessen the pressure of the strap on your shoulder and chest. Allow no more than one inch (2.5 cm) of slack between your chest and the shoulder harness. More slack can significantly reduce the seat belt's effectiveness in an accident or a sudden stop. While holding the belt slack, press the Komfort® latch lever up, clamping the seat belt webbing (Fig. 5.8 and Fig. 5.9).



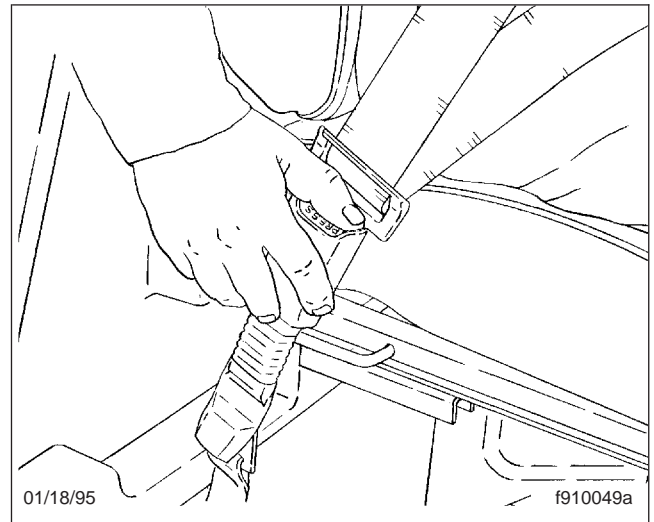
**Fig. 5.8, Adjusting Shoulder Harness Clearance**



**Fig. 5.9, Locking Komfort Latch**

4. To unbuckle the three-point seat belt, push the button on the buckle as shown in Fig. 5.10. If the

Komfort® latch was used, release it by giving the shoulder belt a quick tug. If you lean forward against the shoulder belt, the Komfort® latch will automatically release, and will need to be reset.



**Fig. 5.10, Releasing the Three-Point Seat Belt**

**NOTE:** The Komfort Latch does not have to be released in an emergency situation. The Komfort Latch will release by itself under rough road or other abnormal conditions. Make sure the three-point seat belt is completely retracted when it is not in use.

## Lap Belts With Retractors

The lap belts on some right-hand-drive vehicles have retractors.

To fasten the belt:

1. Pull the belt from the retractor across your hips and insert the tongue into the correct buckle on your seat until you hear a snap and feel it latch. The belt should rest as low on your hips as possible.
2. Make sure the buckle is securely fastened.
3. If you need to lengthen or shorten the belt, unfasten it by pushing the button on the buckle and repeat the above procedure.

Make sure the belt is completely retracted when it is not in use.

# Seats and Seat Belts

## Lap Belts Without Retractors

The center lap belts do not have retractors and therefore should be shortened and fastened when you are not using them. To lengthen your belt, tip the belt tongue at a right angle to the belt and pull the belt over your lap until the tongue reaches the buckle.

To fasten the belt:

1. Pull the belt across your hips and insert the tongue into the correct buckle on your seat until you hear a snap and feel it lock.
2. Make sure the buckle is securely fastened.
3. Adjust the belt so that it fits snugly around your hips:
  - If you need to lengthen the belt, unfasten it and repeat the procedure above.
  - If you need to shorten the belt, pull on the loose end of the webbing.

2. To lengthen the belt, tip the link end downward and pull the link until it connects with the buckle.
3. After the belt is connected, shorten it by pulling on the loose end until the belt is snug, but comfortable. Be sure the belts are not twisted. See [Fig. 5.11](#).

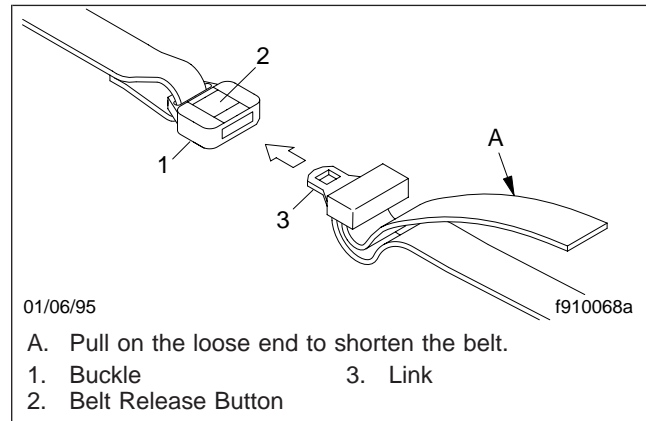


Fig. 5.11, Bunk Restraint Adjustment

## Sleeper Compartment Bunk Restraints

### General Information

On vehicles equipped with a sleeper compartment, bunk restraints should be used whenever the sleeper compartment is occupied and the vehicle is moving. Restraints are designed to lessen the chance of injury or the amount of injury resulting from accidents or sudden stops. For this reason, Sterling Truck Corporation urges the use of bunk restraints when the sleeper compartment is occupied in a moving vehicle.

### WARNING

**Do not use the sleeper compartment while the vehicle is in motion unless a bunk restraint is installed and used. Not using the bunk restraint increases the chance of injury, or the degree of injury, from accidents or sudden stops to all occupants of the vehicle.**

### Bunk Restraint Adjustment

1. Make sure the belt is attached to the bunk support and sleeper wall.

### Bunk Restraint Operation

1. Starting at the foot of the bunk, pull up the link end of the belt far enough to engage the buckle. See [Fig. 5.12](#).

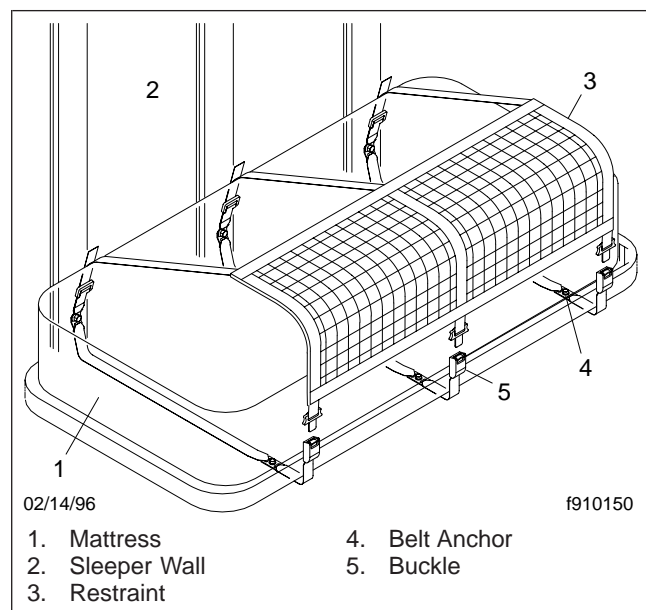


Fig. 5.12, Bunk Restraint

2. Fasten the belt by pushing the link end into the buckle until they latch. Make sure that the belt is not twisted. Check the engagement by trying to pull the link out of the buckle. If they come apart, repeat this step. If the problem continues, replace the belt. Repeat steps 1 and 2 for the other two belts located in the middle and upper portion of the bunk to lock the restraint in place.
3. To release the bunk restraint, push the release button on the buckle at the head of the bunk and pull the link from the buckle.

Repeat this step for the other two buckles to completely release the bunk restraint.

# 6

## Steering and Brake Systems

---

Steering System .....	6.1
Brake System .....	6.1

# Steering and Brake Systems

## Steering System

### General Information

Power steering uses energy from your engine to assist you in steering the vehicle. When the engine is off, or if the power steering system becomes inoperative, the vehicle may still be steered manually, but requires increased driver effort.

#### CAUTION

Never hold the steering wheel against the stops (extreme right or left turn) for more than two seconds, the power steering pump could be damaged.

Do not operate the vehicle with a low power steering pump fluid level, this could cause damage to the power steering pump.

Never steam clean or high-pressure wash the steering gear. Internal damage to gear seals and ultimately the steering gear can result.

### Power Steering System

The power steering system consists of a steering gear (which includes a manual steering mechanism, a hydraulic control valve, and a hydraulic power cylinder), hydraulic hoses, power steering pump, reservoir, and other components. Some models are also equipped with a separate hydraulic power cylinder on the right side of the front axle. The power steering pump, driven by the engine, provides the power assist for the steering system. If the engine is not running, there is no power assist. If the power-assist feature does not work due to hydraulic fluid loss, steering pump damage, or some other cause, bring the vehicle to a safe stop. Do not drive the vehicle until the cause of the problem has been corrected.

#### WARNING

**Driving the vehicle without the power-assist feature of the steering system requires much greater effort, especially in sharp turns or at low speeds, which could result in an accident and possible injury.**

Drivers should carefully use the power available with a power steering system. If the front tires become lodged in a deep chuckhole or rut, drive the vehicle out, instead of using the steering system to lift the

tires from the hole. Also, avoid turning the tires when they are against a curb, as this places a heavy load on steering components and could damage them.

## Brake System

### General Information

After starting the engine, give the air compressor time to build up the air pressure to 60 psi (414 kPa) before moving the vehicle.

#### WARNING

Do not drive the vehicle if the low air pressure buzzer is sounding or the brake warning light is on. These warnings indicate that air pressure is below the normal operating level. Continued use of the vehicle could result in loss of braking ability, possibly causing loss of vehicle control resulting in personal injury or property damage.

#### WARNING

**Avoid repeated light application of the brake pedal. This will deplete air pressure faster and could result in loss of braking capability.**

A dual pointer air pressure gauge is standard (see Fig. 6.1). These pointers register air pressure in each of the two systems.

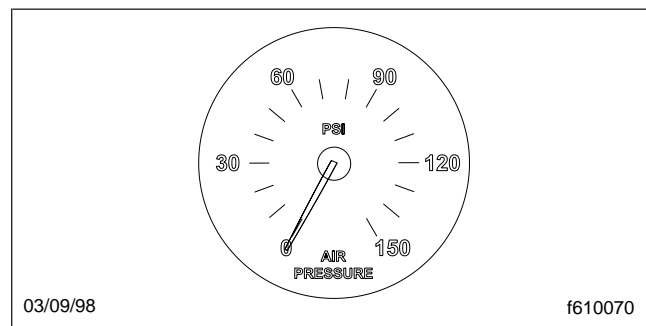


Fig. 6.1, Air Pressure Gauge

Periodically check the air pressure gauge while driving. Pressure should range between approximately 100 to 135 psi (690 to 930 kPa). The air compressor governor cut-in and cut-out pressure settings are preset at the factory and are not adjustable.

# Steering and Brake Systems

When air pressure is low (below 60 psi [534 kPa]), a warning light illuminates and a buzzer sounds when the ignition is in the ON position.

This condition may be caused by excessive brake applications depleting the system air pressure. If this condition occurs, stop driving the vehicle until the compressor has fully recharged the air system. Do not move the vehicle in this condition because the brake system may be inoperative.

Select a gear ratio to help slow your vehicle before descending grades. Supplement with brakes as required to safely slow the vehicle and avoid overspeeding the engine.

On tractor-trailer vehicles, if both the systems become inoperative, the trailer service brakes or spring parking brakes will automatically apply when air pressure drops below 35 to 45 psi (242 to 310 kPa). The tractor spring parking brakes will automatically apply when air pressure drops below 20 to 30 psi (138 to 207 kPa). Do not wait for the brakes to apply automatically; when the warning light and buzzer first come on, immediately bring the vehicle to a safe stop. Before continuing operation of the vehicle, correct the cause of the air loss.

Before the vehicle can be moved, the spring parking brakes must be released by applying an external air source at the gladhands, or by manually caging the parking brake springs.

## WARNING

**Do not release the spring parking brakes and then drive the vehicle. There would be no means of stopping the vehicle, which could result in serious personal injury or vehicle damage. Before releasing the spring parking brakes, make the connection to a towing vehicle or chock the tires.**

After correcting the brake system problem, uncage the spring parking brakes before resuming normal vehicle operation.

## Brake System Operation

Before driving the vehicle, secure all loose items in the cab so that they will not fly forward during a full brake application. Make sure all passengers are wearing seat belts.

During normal brake stops, depress the foot brake control pedal until braking action slows down the vehicle. Increase or decrease the pressure on the

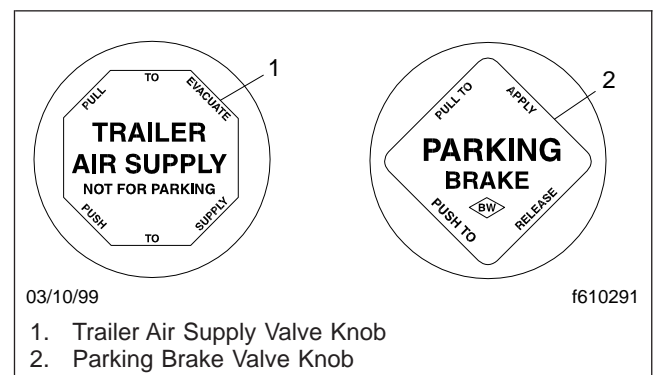
pedal so that the vehicle comes to a smooth, safe stop. Apply the spring parking brakes if the vehicle is to be parked.

**IMPORTANT:** In the event of a total loss of service brakes with full system air pressure, use the parking brake control valve (yellow knob) to bring the vehicle to a complete stop in the safest location possible.

## WARNING

**Do not use the trailer service brakes for parking; they are not designed for this purpose. If air bleeds out of the trailer air tank during parking, the vehicle could roll causing serious personal injury or property damage.**

The red octagonal-shaped knob (Fig. 6.2) in the control panel actuates the trailer air supply valve. After the vehicle's air hoses are connected to a trailer, and the pressure in both air systems is at least 65 psi (448 kPa), the red knob must be pushed in. It should stay in, to charge the trailer air supply system and to release the trailer spring parking brakes; it must be pulled out before disconnecting a trailer. It must also be pulled out when operating a vehicle without a trailer. If pressure in both air systems drops to 35 to 45 psi (242 to 310 kPa), the red knob automatically pops out, exhausting the trailer air supply, and applying the trailer service or spring parking brakes.



**Fig. 6.2, Brake Valve Knobs**

The yellow diamond-shaped knob (Fig. 6.2) in the control panel actuates the parking brake valve. Pulling out the knob applies both the tractor and trailer spring parking brakes and automatically causes the trailer air supply valve knob to pop out.



# Steering and Brake Systems

---

## CAUTION

**Do not use the spring parking brakes if the service brakes are hot, such as after descending a steep grade. Also, do not use the spring parking brakes during freezing temperatures if the service brakes are wet. To do so could damage the brakes if hot, or cause them to freeze during cold weather.**

**If the brakes are wet, drive the vehicle in low gear and lightly apply the brakes to heat and dry them. Allow hot brakes to cool before using the spring parking brakes. Always chock the tires.**

If the trailer is not equipped with spring parking brakes, pulling out the yellow knob applies the tractor spring parking brakes and the trailer service brakes. When the tractor and trailer parking brakes (or trailer service brakes) are both applied, the trailer brakes are released by pushing in the red knob, leaving the tractor parking brakes applied. Air pressure in the primary or secondary reservoir must be at least 65 psi (447 kPa) before the tractor spring parking brakes, or the trailer service or spring parking brakes, can be released.

On trailers not equipped with spring parking brakes, chock the trailer tires before disconnecting the truck or tractor when parking just the trailer.

When parking a truck or tractor with a trailer (combination vehicle), and the trailer is not equipped with spring parking brakes, apply the truck or tractor spring parking brakes.

## WARNING

**If a trailer is not equipped with spring parking brakes, do not park it or a combination vehicle by pulling out only the trailer air supply valve knob. This would apply only the trailer service brakes. If air were to bleed from the trailer brake system, the trailer brakes would release, possibly causing an unattended runaway vehicle.**

## CAUTION

**Never apply the service and spring parking brakes simultaneously. To do so transmits excessive input force to the brake components, which could damage or cause eventual failure of brake actuating components.**

## Antilock Braking System (ABS)

The Antilock Braking System (ABS) is an electronic wheel speed monitoring and control system that works with the standard air brake system. ABS passively monitors vehicle wheel speed at all times, and *controls* wheel speed during emergency stops. In normal braking applications, the standard air brake system is in effect.

**IMPORTANT:** For proper ABS system operation, do not change tire sizes. The sizes of the tires installed during production are programmed into the electronic control unit. Installing different sized tires could result in a reduced braking force, leading to longer stopping distances.

ABS includes signal-generating tone wheels and sensors located in the wheel hubs of each sensed wheel. The sensors transmit vehicle wheel speed information to an electronic control unit (located in a panel behind the driver's seat). The control unit's main circuit interprets the speed sensor signals and calculates wheel speed, wheel retardation, and a vehicle reference speed. If the calculations indicate wheel lockup, the main circuit signals the appropriate solenoid control valve to reduce braking pressure. During emergency braking, the solenoid control valve alternately reduces, increases, or maintains air pressure supply in the brake chamber to prevent front and rear wheel lockup.

The electronic control unit also has a safety circuit that constantly monitors the wheel sensors, solenoid control valves, and the electrical circuitry.

After the ignition switch is turned on, the ANTILOCK warning light will come on for about three seconds. After three seconds, the warning light will go out only if all of the tractor's ABS components are working.

If, during vehicle operation, the safety circuit senses a failure in any part of the ABS system (a sensor, solenoid control valve, wiring connection, short circuit, etc.), the tractor warning light (ANTILOCK) comes on and the control circuit where the failure occurred is switched to normal braking action. The remaining control circuits will retain the ABS effect. Even if the ABS system is completely inoperative, normal braking ability is maintained. An exception would be if a solenoid control valve (or combination solenoid control valve) is damaged and inoperative. As these components are an integral part of the air

brake system, normal braking may be impaired or inoperative.

**IMPORTANT:** If any of the ABS warning lights do not work as described above, or come on while driving, repair the ABS system immediately to ensure full antilock braking capability.

During emergency or reduced-traction stops, fully depress the brake pedal until the vehicle comes to a safe stop; *do not pump* the brake pedal. With the brake pedal fully depressed, the ABS system will control all wheels to provide steering control and a reduced braking distance.

Although the ABS system improves vehicle control during emergency braking situations, the driver still has the responsibility to change driving styles depending on the existing traffic and road conditions. For example, the ABS system cannot prevent an accident if the driver is speeding or following too closely.

## Trailer ABS Lamp Operation

Antilock braking systems on tractors are designed to communicate with trailer ABS systems, if they are compatible. Compatibility will result in the illumination of the trailer ABS lamp during vehicle start-up and fault detection.

The dash-mounted lamp will operate as follows when a compatible trailer is properly connected to a tractor:

- When the ignition key is turned to the ON position, the trailer ABS lamp will illuminate momentarily, then turn off.
- If the lamp comes on momentarily during vehicle operation, then shuts off, a fault was detected and corrected.
- If the lamp comes on and stays on during vehicle operation, there is a fault with the trailer ABS. Repair the trailer ABS system immediately to ensure full antilock braking capability.

The Trailer ABS lamp will not illuminate unless a compatible trailer is connected to the tractor.

**IMPORTANT:** If a compatible trailer is connected, and the lamp is not illuminating momentarily when the ignition key is turned to the ON position, it is possible that the lamp is burnt out.

## Automatic Slack Adjusters

Automatic slack adjusters are required on all vehicles equipped with air brakes manufactured after October 20, 1994. Automatic slack adjusters should never be manually adjusted except during routine maintenance of the foundation brakes (e.g., replacing shoes), during slack adjuster installation or in an emergency situation.

When the brake pushrod stroke exceeds the legal brake adjustment limit on a vehicle, there is likely a mechanical problem with the foundation brake components or the adjuster is improperly installed.

Visit a repair facility as soon as possible when brakes equipped with automatic slack adjusters are determined to be out of adjustment.



**Manually adjusting an automatic slack adjuster to bring the pushrod stroke within legal limits is likely masking a mechanical problem. Adjustment is not repairing. In fact, continual adjustment of automatic slack adjusters may result in premature wear of the adjuster itself. Further, the improper adjustment of some automatic slack adjusters may cause internal damage to the adjuster, thereby preventing it from properly functioning.**

# 7

## Engines and Clutches

---

EPA07 Aftertreatment System (ATS) .....	7.1
DD15 Heavy-Duty Engine .....	7.3
Engine Starting, CAT, Cummins, DDE S60, M-B .....	7.6
Cold-Weather Operation, CAT, Cummins, DDE S60, M-B .....	7.8
Engine Break-In, CAT, Cummins, DDE S60, M-B .....	7.11
Engine Operation, CAT, Cummins, DDE S60, M-B .....	7.11
Engine Shutdown, CAT, Cummins, DDE S60, M-B .....	7.19
High-Altitude Operation, CAT, Cummins, DDE S60, M-B .....	7.21
Engine Braking System, CAT, Cummins, DDE S60, M-B .....	7.21
Clutches .....	7.25

# Engines and Clutches

---

## EPA07 Aftertreatment System (ATS)

On-road diesel engines built after December 31, 2006 are required to meet EPA07 guidelines for reduced exhaust emissions of particulate matter and nitrogen oxides (NOx). NOx is limited to just over 1 gram per brake horsepower hour (g/bhp-hr), and particulate matter cannot exceed 0.01 g/bhp-hr.

EPA07-compliant engines require ultralow-sulfur diesel (ULSD) fuel, and they should never be run on fuel with sulfur content higher than 15 ppm. In addition, they require low-ash engine oil. The following guidelines must be followed, or the warranty may be compromised.

- Use ultralow-sulfur diesel (ULSD) with 15 ppm sulfur content or less, based on ASTM D2622 test procedure.
- Do not use fuel blended with used engine lube oil or kerosene.
- Engine lube oil must have a sulfated ash level less than 1.0 wt %, meeting the API CJ-4 index specifications.

**IMPORTANT:** Using non-specification fuels or oils can lead to shortened diesel particulate filter (DPF) cleaning or exchange intervals. For example, using CI-4+ oil with 1.3% sulfated ash (30% more ash content) may result in the need for DPF cleaning or exchange 20 to 30% sooner than would normally be required.

The "exhaust system" in EPA07-compliant vehicles is called the aftertreatment system (ATS). The ATS varies according to engine manufacturer and vehicle configuration, but instead of a muffler, an aftertreatment system has a device that outwardly resembles a muffler, called the aftertreatment device (ATD).

**IMPORTANT:** See your engine operation manual for complete details and operation of the aftertreatment system.

Inside the ATD on Mercedes-Benz, Detroit Diesel, and Cummins engines, the exhaust first passes over the diesel oxidation catalyst (DOC), then it passes through the diesel particulate filter (DPF), which traps soot particles. If exhaust temperature is high enough, the trapped soot is reduced to ash, in a process called passive regeneration (regen). **Passive regen-**

**eration** occurs as the vehicle is driven normally under load; the driver is not even aware that it is happening. The harder an EPA07 engine works, the better it disposes of soot, as the exhaust heat alone is enough to burn the soot to ash. Over the course of a workday, however, passive regeneration cannot always keep the ATD filter clean, so the filter must undergo **active regeneration**. In active regeneration, extra fuel is injected into the exhaust stream to superheat the soot trapped in the DPF and turn it to ash. Active regeneration happens only when the vehicle is moving above a certain speed, determined by the engine manufacturer. Consult manufacturers' documentation for details.

Both active and passive regeneration happen automatically, without driver input.

**NOTE:** Caterpillar engines do not use a DOC; CAT engines burn diesel fuel at the regeneration heat to superheat the exhaust and burn the trapped soot to ash. Engine software monitors and controls this process.

Only when operating conditions do not allow for ATD filter cleaning by active or passive regeneration, the vehicle may require a driver-activated **parked regeneration**. The vehicle must be standing still, and the driver must initiate a parked regen. Completing a parked regen takes 20 minutes to an hour, depending on ambient conditions.



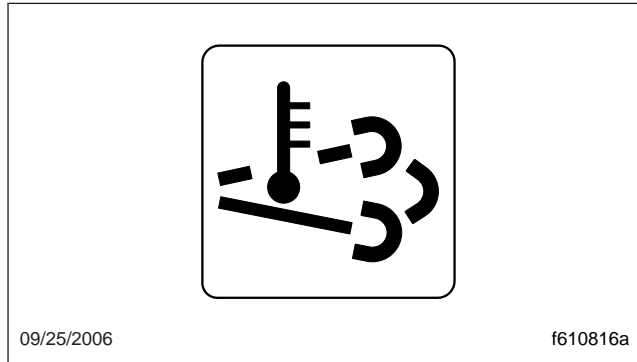
**During parked regeneration, exhaust temperatures are very high, and could cause a fire, heat damage to objects or materials, or personal injury to persons near the exhaust outlet.**

**Before a parked regeneration, make certain the exhaust outlets are directed away from structures, trees, vegetation, flammable materials, and anything else that may be damaged or injured by prolonged exposure to high heat.**

The warning lamps in the driver message center alert the driver of a regen in progress, high exhaust temperatures, the need to perform a parked regen either soon or immediately, and of an engine fault that affects the emissions.

A slow (10-second) flashing of the high exhaust system temperature (HEST) lamp indicates that a parked regeneration is in progress, and the engine's

high idle speed is being controlled by the engine software, not the driver. See [Fig. 7.1](#).



**Fig. 7.1, High Exhaust System Temperature (HEST) Lamp**

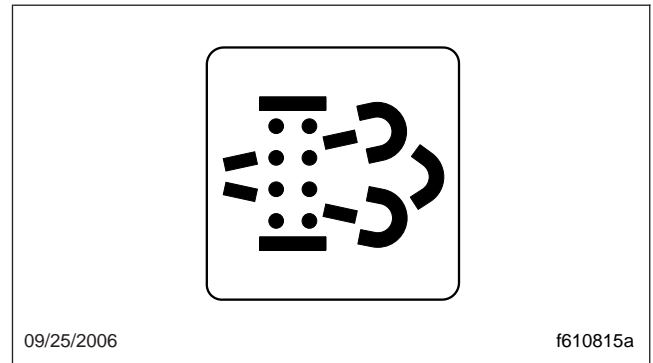
A steadily illuminated high temperature (HEST) lamp alerts the operator of high exhaust temperature during the regeneration process, if vehicle speed is below 5 mph (8 km/h). The HEST lamp does not signify the need for any kind of vehicle or engine service; it only alerts the vehicle operator of high exhaust temperatures. Make sure the engine exhaust pipe outlet is not directed at any person, or at any surface or material that will melt, burn, or explode.

**⚠ WARNING**

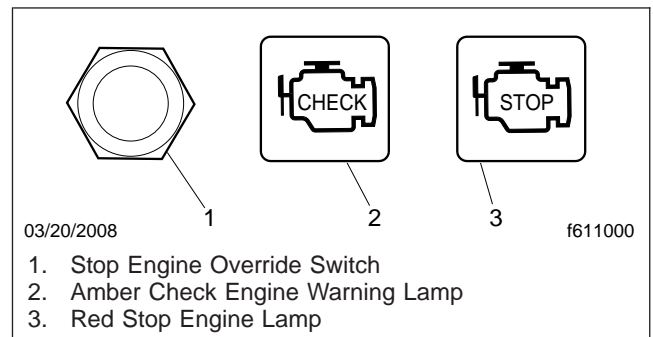
**Automatic regeneration can occur any time the vehicle is moving, and the exhaust can remain hot after the vehicle has stopped moving. The exhaust gas temperature could reach 1500°F (800°C), which is hot enough to ignite or melt common materials, and to burn people.**

A steadily illuminated yellow diesel particulate filter (DPF) lamp indicates that a regen may be required soon. Bring the vehicle to highway speeds to allow for an active regen, or a parked regen should be scheduled for the earliest convenient time. See [Fig. 7.2](#).

A DPF lamp blinking at the same time as a steadily illuminated yellow Check Engine lamp, indicates that a parked regen must be performed immediately, or an engine derate will occur. If the red Stop Engine lamp illuminates with the blinking DPF lamp and the Check Engine lamp, a parked regen must occur or an engine shutdown will occur. Park the vehicle and perform a parked regen. See [Fig. 7.3](#).

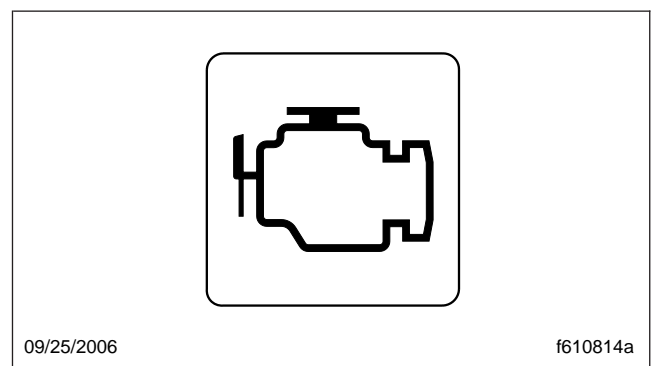


**Fig. 7.2, Diesel Particulate Filter (DPF) Status Lamp**



**Fig. 7.3, Engine Lamps**

A steadily illuminated yellow malfunction indicator lamp (MIL) indicates an engine fault that affects the emissions. See [Fig. 7.4](#).



**Fig. 7.4, Malfunction Indicator Lamp (MIL)**

When diesel particulate filter servicing is needed, it must be performed by an authorized technician, and a record must be maintained for warranty purposes. The record must include:

- date of cleaning or replacement;

# Engines and Clutches

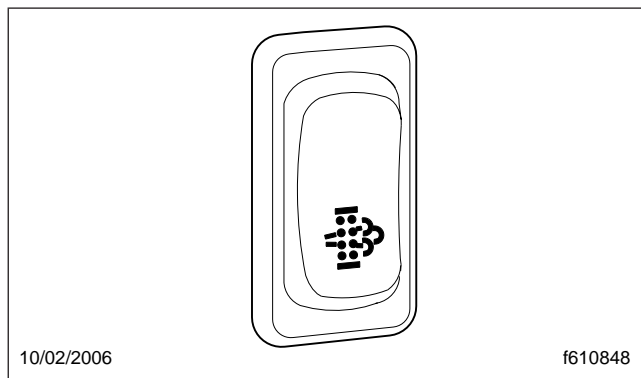
- vehicle mileage;
- particulate filter part number and serial number.

The request/inhibit regen switch (**Fig. 7.5**), located on the dash, can have three selectable positions:

- request regeneration;
- default (either automatic regeneration or inhibit state);
- inhibit regeneration.

**NOTE:** The regen switch can start a parked regen only when at least one of two conditions exists: either the DPF light is lit, or the engine software calls for it. If neither of those conditions exist, the regen switch cannot cause a regeneration to happen.

The function of the switch will vary by the engine make and model in the vehicle. See the engine operation manual for switch operation details.



**Fig. 7.5, Request/Inhibit Regen Switch**

## DD15 Heavy-Duty Engine

See **Chapter 2** of this manual for information on the DDEC VI operator controls. See the *Detroit Diesel DD15 Engine Operator's Guide* for complete details of engine operation.

### Engine Protection

An engine protection system monitors all engine sensors and electronic components, and recognizes system malfunctions. If a critical fault is detected, an amber Check Engine warning lamp and a red Stop Engine lamp illuminate. See **Fig. 7.3**.

The standard parameters that are monitored for engine protection are: low coolant level, high coolant temperature, low oil pressure, and high oil temperature.

### Amber Check Engine Warning Lamp

When the amber Check Engine warning lamp comes on for any reason, the vehicle can still be operated, and the driver can proceed to the required destination. See **Fig. 7.3**. This condition should be reported to an authorized service center as soon as possible.

### Red Stop Engine Lamp

When the red Stop Engine lamp comes on, the computer has detected a major malfunction in the engine that requires immediate attention. See **Fig. 7.3**. **It is the operator's responsibility to shut down the engine to avoid serious damage.** This system features a 30-second, stepped-down power-shutdown sequence, or an immediate emergency-running mode, in the event that a major engine malfunction occurs. The conditions that will cause the red Stop Engine lamp to come on are:

- high coolant temperature
- loss of coolant
- high oil temperature
- low oil pressure
- auxiliary shutdown

### Stop Engine Override Switch

In the event that the vehicle is operating in a critical location when a shutdown is initiated, a Stop Engine Override (SEO) switch can be used to override the shutdown sequence. See **Fig. 7.3**. This override resets the shutdown timer, restoring power to the level when the red stop engine lamp was illuminated. The switch must be recycled after five seconds to obtain a subsequent override.



**Using the override button so the engine operates for an extended period may result in engine damage. The operator has the responsibility to take action to avoid engine damage.**

## DDEC VI Driving Tips

### Accelerating the Vehicle

The accelerator pedal was designed to communicate "percentage" of accelerator pedal travel to the engine MCM. A throttle characteristic you may need time to get used to, is the DDEC limiting speed governor. This allows the driver to command total engine response between idle and rated speed, such as accelerating at half throttle—an advantage when driving under slippery conditions. To obtain 100 percent fueling at any speed, the accelerator pedal must be depressed to the fully pressed position.

### Shifting

Depending on your transmission model, the gear split may vary from 400 to 500 rpm. The electronic governor provides almost no overrun capability; if the transmission is downshifted too early, you will experience a temporary loss of pulling power until the engine speed falls below rated speed. In general, when using a 9-speed transmission, you should always downshift between 1000 and 1100 rpm. This is true even on steep grades with heavy loads. When using an 18-, 15-, or 13-speed transmission, you will need to downshift at an rpm that allows "less than rated" rpm, before throttle application in the next gear down. You may want to limit engine speed to 1900 rpm in all gears.

The DD15 engine provides horsepower through 2100 rpm, but fuel economy is not as efficient above 1800 rpm. If you decide to drive at lower rpm for improved fuel economy, don't let different engine noises throw you off guard. The DD15 engine sounds quiet at 1400 rpm, almost as if it had quit pulling. If you had a boost gauge to look at while driving, you would notice the turbocharger maintaining steady intake manifold pressure, even as rpm falls. Depending on the air intake arrangement, you may also hear a "chuffing" sound as the engine starts to pull hard at lower rpm. This is normal, and caused by the velocity changes of the air flow within the air intake plumbing. Electronic engines can actually deliver more fuel at lower engine speeds than at rated speed.

The DD15 engine has been designed for a very quiet operation, but the air flow may be noticeable to the tuned attentive ear. The turbocharger operates at higher boost pressure, forcing exhaust to flow through the exhaust gas recirculation plumbing. In some situations the driver may believe they have ex-

perienced a charge air cooler system leak. Even while connecting trailer lights and air hoses, the driver may hear a different tone (exhaust and under hood with the engine idling). If equipped with a turbo boost gauge, the driver may occasionally note the intake manifold pressure exceeds 35 psi (241 kPa).

### Idling

The common belief that idling a diesel engine causes no engine damage is wrong. Idling produces sulfuric acid, that is absorbed by the lubricating oil, and eats into bearings, rings, valve stems, and engine surfaces. If you must idle the engine for cab heat or cooling, the high idle function of the cruise control switches should be used. An idle speed of 900 rpm should be enough to provide cab heat in above freezing ambient temperatures.

### Cold-Weather Operation

Precautions must be taken during cold weather to protect your engine. Special cold-weather handling is required for fuel, engine oil, coolant, and batteries. The engine does not require starting aids down to 50°F (10°C). A grid heater is included for temperatures between 50°F (10°C) and -4°F (-20°C). Temperatures below -4°F (-20°C), will require a grid heater, block heater, and oil pan heater.

## CAUTION

**NEVER use ether as a starting aid to run a DD15 engine. Doing so will result in injector damage.**

A winterfront may be used to improve cab heating. At least 25 percent of the grill opening should remain open in sectioned stripes that run perpendicular to the charge air cooler tube flow direction. This assures even cooling across each tube, and reduces header-to-tube stress and possible failure. Winterfronts should only be used when the ambient temperature remains below 10°F (-12°C).

### Driving on Flat, Dry Pavement

Use the following guidelines when driving on flat, dry pavement.

- If driving on flat, dry, open stretches, with a light load, place the progressive braking switch in the LOW position.
- If you find you are still using the service brakes, move the switch to a higher position

# Engines and Clutches

---

until you do not need to use the service brakes to slow the vehicle.

- If you are carrying a heavier load and road traction is good, move the progressive braking switch to the HIGH position.
- Check your progressive braking switch often for proper position, since road conditions can change quickly. Never skip a step when operating the progressive braking switch. Always go from OFF to LOW, and then to a higher position.

## Descending a Long, Steep Grade

An explanation of "control speed" may be helpful in understanding how to use the engine brake system while descending a grade. Control speed is the constant speed at which the forces pushing the vehicle forward on a grade, are equal to the forces holding it back, without using the vehicle service brakes. In other words, this is the speed the vehicle will maintain without using the service brakes or throttle.

### CAUTION

**Do not over apply the vehicle service brakes when descending a long, steep grade. Excessive use of the vehicle brakes will cause them to heat up, reducing their stopping ability. This condition, referred to as "brake fade", may result in loss of braking, which could lead to loss of control of the vehicle, resulting in personal injury or property damage.**

Use the following guidelines when descending a long, steep grade.

- Before beginning the descent, determine if your engine brake system is operating properly, by lifting your foot briefly off the accelerator pedal. You should feel the system activate.
- Ensure the progressive braking switch is in the appropriate power position. Check your progressive braking switch often for proper position, since road conditions can change quickly. Never skip a step when operating the progressive braking switch. Always go from OFF to LOW and then to a higher position when on slippery roads.
- Do not exceed the safe control speed of your vehicle. Example: You could descend a 6 per-

cent grade, under control at 10 mph (16 km/h) without an engine brake, but at 25 mph (40 km/h) it requires an engine brake. You could not descend that same hill at 50 mph (80 km/h) and still expect to remain under control. Know how much slowing power your engine brake can provide before descending hills, and do not exceed a safe control speed.

## Driving on Wet or Slippery Pavement

### WARNING

**To avoid injury from loss of vehicle control, do not activate the engine brake system under the following conditions:**

- on wet or slippery pavement, unless the vehicle is equipped with ABS (antilock braking system) and you have had prior experience driving under these conditions;
- when driving without a trailer (bobtailing) or pulling an empty trailer;
- if the tractor drive wheels begin to lock, or there is fishtail motion after the engine brake is activated.

NOTE: On single trailers or combinations, a light air application of the trailer brakes may be desirable to help keep the trailer stretched out. Follow the manufacturer's recommended operating procedure when using the trailer brakes.

On wet or slippery pavement, start with the master switch in the OFF position and use the gear you would normally use under these conditions. If the vehicle is maintaining traction, place the selective braking switch in the LOW position and turn ON the engine brake system. If the drive wheels are maintaining traction and you desire greater slowing power, move the braking switch to the next higher position. However, if the tractor drive-wheels begin to lock, or there is a fishtail motion, turn the engine brake system OFF immediately and do not activate it until road conditions improve.

Check your progressive engine braking switch often for proper position, since road conditions can change quickly. Never skip a step when operating the progressive braking system. Always go from OFF to LOW and then to a higher position. See [Chapter 2](#) for the proper operation of the engine brake.



## Engine Starting, CAT, Cummins, DDE S60, M-B

### CAUTION

When starting a vehicle equipped with a manual transmission and clutch lockout switch, the clutch pedal must be fully depressed during the entire start sequence. Failure to do so can cause the pinion to release and re-engage, which could cause ring gear and starter pinion damage.

If a vehicle does not start on the first attempt, make sure that the engine has completely stopped rotating before reapplying the starter switch. Failure to do so can cause the pinion to release and re-engage, which could cause ring gear and starter pinion damage.

Moving a vehicle with the starter and/or using the starter to bump the engine for maintenance procedures is strictly prohibited. Use of these methods to bump the engine over or move the vehicle can cause the pinion to release and re-engage, which could cause ring gear and starter pinion damage.

**IMPORTANT:** The starter can not be used for priming the fuel system. See the engine operation manual for priming instructions. Ring gear and starter pinion damage caused by improper starting procedures is not warrantable.

## Caterpillar

**NOTE:** Before starting the engine, read [Chapter 2](#) for detailed information on how to read the instruments and operate the controls.

The information below contains guidelines for cold-weather starting. For additional information, refer to "Ether Start System."

### WARNING

**Do not use any starting aid, such as ether, in engines with an intake air preheater. This could cause an explosion, resulting in serious personal injury or death.**

1. Before engine start-up, perform the engine pre-trip inspection and daily maintenance checks in [Chapter 11](#).

2. Set the spring parking brakes.
3. Place the transmission in neutral and disengage the clutch.

**NOTE:** On vehicles equipped with a neutral start switch, the transmission must be in neutral before the engine can be started. For air start systems, check the air supply before starting the engine. There must be 100 psi (689 kPa) of air pressure available.

4. Push the accelerator pedal to the floor once, then release it.

### CAUTION

**Do not crank the engine for more than 30 seconds at a time. Wait two minutes after each try to allow the starter to cool. Failure to do so could cause starter damage.**

**NOTE:** Some starters are equipped with an optional thermostat. If overcranking occurs, the thermostat breaks the electrical circuit to the starter motor until the motor has cooled.

5. Turn on the ignition switch. Release the switch the moment the engine starts.
6. If the engine doesn't start after the previous step, turn the ignition switch. After the engine begins to crank, push the accelerator pedal down halfway and hold it while cranking. As soon as the engine starts, release the accelerator pedal so the engine runs at low idle, and release the ignition switch.
7. Do not apply a load to the engine or increase the engine speed until the oil pressure gauge reading is normal. Within 15 seconds after the engine starts, oil pressure should rise 10 to 20 psi (69 to 138 kPa) for C-10 engines, and 18 psi (124 kPa) for 3406E engines. If low oil pressure or no oil pressure is indicated, shut down the engine immediately to prevent serious damage. Do not operate the engine until the cause of the problem has been corrected. If the vehicle is equipped with an automatic shutdown system, the engine will shut down after 30 seconds if the oil pressure does not build up to the preset minimum. If the engine shuts down, do not operate it (except in an emergency) until the cause of the problem has been corrected.

# Engines and Clutches

---

8. Operate the engine at low load. After normal oil pressure is reached and the temperature gauge begins to move, the engine may be operated at full load. Check all gauges during the warm-up period.

## Cummins and Detroit Diesel S60

NOTE: Before starting the engine, read **Chapter 2** for detailed information on how to read the instruments and operate the controls. On vehicles equipped with a neutral start switch, the transmission must be in neutral before the engine can be started.

1. Before engine start-up, perform the engine pretrip inspection and daily maintenance checks in **Chapter 11**.
2. Set the spring parking brakes.



### CAUTION

**Protect the turbocharger during the start-up by not opening the throttle or accelerating the engine above 1000 rpm until normal engine idle oil pressure registers on the gauge.**

3. Set the throttle idle (hold down the clutch pedal).
4. Make sure the transmission is in neutral.



### CAUTION

**Do not crank the engine for more than 30 seconds at a time. Wait two minutes after each try to allow the starter to cool. Failure to do so could cause starter damage.**

IMPORTANT: For Detroit Diesel engines, pumping the accelerator before or during cranking will not aid in starting. If the engine won't start, check the main engine power fuses; they may have blown. The fuses are located along the main engine electrical harness on the left frame rail, near the batteries. If needed, replace the fuses. Be sure to find the cause of the blown fuses as soon as possible.

5. Turn on the ignition switch. Release the switch the moment the engine starts.

NOTE: Some starters are equipped with an optional thermostat. If overcranking occurs, the

thermostat breaks the electrical current to the starter motor until the motor has cooled.

6. When the engine is started, it takes a while to get the lubricating oil film reestablished between the shafts and bearings, and between the pistons and liners. Bring the engine up to operating speed gradually as it warms up and develops stable oil pressure.

The oil pressure gauge indicates any drop in lubricating oil pressure or mechanical malfunction in the lubricating oil system. The operator should note the loss of oil pressure and shut down the engine before damage can occur.

7. During the warm-up period, apply the load gradually until the oil temperature reaches 140°F (60°C). For an engine starting a loaded vehicle, the minimum coolant temperature must be approximately 120°F (49°C).

## Starting After Extended Shutdown or Oil Change

Do the following steps after an oil change or after the engine has been shut down for more than 3 days:

1. Disconnect the electrical connector from the fuel pump solenoid valve.
2. Crank the engine until oil pressure shows on the gauge.
3. Connect the electrical connector to the fuel pump solenoid valve.
4. Start the engine. After one minute, shut down the engine and check for leaks.
5. Allow five minutes for the oil to settle, then check the engine oil level and add oil if needed. Do not overfill.

## Mercedes-Benz

1. Perform the engine pretrip inspection and daily maintenance checks in **Chapter 11**.
2. Set the parking brake.
3. For manual transmissions, place the transmission in neutral and disengage the clutch.

For automatic transmissions, make sure the transmission shift control is in neutral or park.

## CAUTION

Never attempt to start any Mercedes-Benz electronic engine using ether or any other starting fluid. Serious engine damage could result.

NOTE: On vehicles equipped with a neutral start switch, the transmission must be in neutral before the engine can be started. For air start systems, check the air supply before starting the engine. There must be 100 psi (689 kPa) of air pressure available.

4. Turn the ignition switch to the ON position. All the electronic gauges on the ICU (instrumentation control unit) complete a full sweep of their dials, the warning and indicator lights light up, and the buzzer sounds for 3 seconds.

IMPORTANT: On vehicles equipped with an intake air preheater, the INTAKE HEATER indicator stays on for a minimum of 2 seconds, regardless of coolant temperature. Wait until the INTAKE HEATER indicator goes out before attempting to start the engine.

5. Turn the ignition switch to the start position. Without touching the throttle pedal, start the engine.

NOTE: Some starters are equipped with optional overcrank protection. If overcranking occurs, a thermostat breaks the electrical circuit to the starter motor until the motor has cooled.

6. It is not necessary to idle the engine before engaging or starting the operation, but load should be applied gradually during the warm-up period until the oil temperature reaches 140°F (60°C).
7. Check the oil pressure gauge for any drop in lubricating oil pressure or mechanical malfunction in the lubricating oil system. Minimum oil pressure at idle is 7 psi (50 kPa).

## CAUTION

**Do not rev the engine if the oil pressure gauge indicates no oil pressure. Shut down the engine if no oil pressure appears within approximately ten seconds. Check to determine the cause of the problem. Operating the engine with no oil pressure will damage the engine.**

## Cold-Weather Start Systems

### CAUTION

Never attempt to start any Mercedes-Benz electronic engine using ether or any other starting fluid. Serious engine damage could result.

### WARNING

If using a cold-weather-start system, be sure to follow the manufacturer's instructions regarding its use, handling, and storage. Many starting fluids are in capsules or pressure cans, and improper usage can be dangerous.

**Do not attempt to use any type of vapor-compound start system near heat or open flame. Engine damage due to an explosion or fire in the intake manifold could result.**

**Do not breathe the ether fumes; doing so could result in personal injury.**

Caterpillar truck engines with direct injection are designed to start at temperatures above 10°F (-12°C) without using start systems. If the temperature is below 10°F (-12°C), a start system may be necessary and/or crankcase oil may need to be heated. Jacket water heaters are often used to assist starting in low temperatures.

The cold start system, approved for use on Cummins engines, has been based upon starting aid capabilities to -25°F (-32°C).

See the manufacturer's *Engine Operation Manual* for your engine, before using any cold start system.

## Cold-Weather Operation, CAT, Cummins, DDE S60, M-B

### Caterpillar

If the engine is in good mechanical condition and the precautions necessary for cold-weather operation are taken, ordinary cold weather will not cause difficulty in starting or loss of efficiency.

If the engine does not start, prime the fuel system.

IMPORTANT: If a winterfront is used on a vehicle with an electronic engine equipped with a charge air cooler, make sure that there are slit

# Engines and Clutches

---

openings distributed across the face of the winterfront to allow airflow through the entire charge-air-cooler core. Do not use a winterfront with closed areas that block uniform air flow across any sections of the charge-air-cooler crossflow tubes. This will adversely affect the operation and durability of the charge air cooler.

For cold-weather operation, use the following guidelines:

1. When starting the engine in temperatures below 32°F (0°C), use engine lubricants of lower viscosity. Refer to your *CAT Engine Operation and Maintenance Manual* for specifications.
2. When the temperature is below freezing, use sufficient antifreeze solution in the cooling system to prevent freezing.
3. During cold weather, give more attention to the condition of the batteries. Test them frequently to ensure sufficient power for starting. Inspect all switches and connections in the electrical system and keep them in good condition to prevent losses through poor contacts. See **Group 15** of the *L-Line and A-Line Workshop Manual* for detailed information.
4. If so equipped, turn off the battery disconnect switch after the engine is stopped, to prevent battery discharge while the starter motor is cooling.

For starting below 0°F (-18°C), an optional cold-weather starting assist is recommended. For temperatures below -10°F (-23°C), consult your Caterpillar dealer for recommendations.

## **WARNING**

**Do not use any starting aid, such as ether, in engines with an intake air preheater. This could cause an explosion, resulting in serious personal injury or death.**

5. When customer parameters include cold mode operation and the coolant temperature is below 64°F (18°C), the system puts the engine in cold mode, limiting engine power, advancing timing, and adjusting the low idle to 600 rpm to improve warm-up time. The system will keep the engine in cold mode until coolant temperature rises above 64°F (18°C) or until the engine has been running for 12 minutes. The system will then stop

the cold mode and allow the engine to operate normally.

6. Fuel cloud point is the temperature at which wax crystals become visible, which is generally above the pour point of the fuel. To keep the fuel filter elements from plugging with wax crystals, the cloud point should be no higher than the lowest ambient temperature at which the engine must start.

## Cummins

Satisfactory performance of a diesel engine operating in low ambient temperatures requires modification of the engine, surrounding equipment, operating practices, and maintenance procedures. The lower the temperatures the greater the amount of modification required, and yet with the modifications applied, the engines must still be capable of operation in warmer climates without extensive changes.

The following information is provided to engine owners, operators, and maintenance personnel on how the modifications can be applied to get satisfactory performance from their diesel engines.

There are three basic objectives:

- Reasonable starting characteristics followed by practical and dependable warm up of the engine and equipment.
- A unit or installation which is as independent as possible from external influences.
- Modifications which maintain satisfactory operating temperatures with a minimum increase in maintenance of the equipment and accessories.

If satisfactory engine temperature is not maintained, higher maintenance cost will result due to increased engine wear. Special provisions to overcome low temperatures are definitely necessary, whereas a change to a warmer climate normally requires only a minimum of revision. Most of the accessories should be designed in such a way that they can be disconnected so there is little effect on the engine when they are not in use.

The two most commonly used terms associated with preparation of equipment for low-temperature operation are "winterization" and "arctic specifications."

Winterization of the engine and/or components so that starting and operating are possible in the lowest temperature to be encountered, requires:

- Proper lubrication with low-temperature lubricating oils.
- Protection from the low-temperature air. The metal temperature does not change, but the rate of heat dissipation is affected.
- Fuel of the proper grade for the lowest temperature.
- Heat to raise the engine block and component temperatures to at least  $-25^{\circ}\text{F}$  ( $-32^{\circ}\text{C}$ ) for starting in lower temperatures.
- Electrical equipment capable of operating in the lowest expected temperature. All switches, connections, and batteries in the electrical system should be inspected and kept in good condition to prevent losses through poor contacts.

Arctic specifications refer to the design of material and specifications of components necessary for satisfactory engine operation in extremely low temperatures to as low as  $-65^{\circ}\text{F}$  ( $-54^{\circ}\text{C}$ ). Contact the nearest Sterling dealer or Cummins engine dealer to obtain the special items required.



## CAUTION

**"Antileak" antifreezes are not recommended for use in Cummins engines. Although these antifreezes are chemically compatible with DCA water treatment, the "antileak" agents may clog the coolant filters.**

**IMPORTANT:** Fuel heaters used on vehicles with Cummins CELECT Plus engine systems could cause high fuel temperatures that affect engine performance and operation of the electronic engine controls. If a fuel heater is used, make sure it has thermostatic controls. If the fuel heater has a timer, set the timer to activate only for a limited period of time before the engine starts. Make sure the fuel heater is used only for starting the engine.

## Detroit Diesel S60

Preparations made in advance of winter and maintenance performed during the cold months will help to ensure efficient engine starting and operation.

- Engine oil thickens as it gets colder, slowing cranking speed. When cold, multigrade oil offers less resistance to the cranking effort of the engine and permits sufficient rpm to be developed to start the engine. Refer to "Lubricating Oil Recommendations" in the *Detroit Diesel Owner's and Operator's Guide* for specific recommendations.
- A winterfront may be used to improve cab heating while idling. At least 25% of the grille opening should remain open in sectioned stripes that run perpendicular to the charge air cooler tube flow direction. This assures even cooling across each tube and reduces header-to-tube stress, and possible failure. Winterfronts should only be used when the ambient temperature remains below  $10^{\circ}\text{F}$  ( $-12^{\circ}\text{C}$ ).
- When an engine equipped with a DDEC system is started at temperatures below  $25^{\circ}\text{F}$  ( $-4^{\circ}\text{C}$ ), the idle speed automatically increases to 900 rpm. The injection timing is also advanced to decrease white smoke. As the engine oil warms up, the idle speed gradually decreases. When the oil temperature reaches  $122^{\circ}\text{F}$  ( $50^{\circ}\text{C}$ ), both the idle speed and the injection timing return to normal.
- During cold weather, the batteries should be tested more frequently to ensure ample power for starting. All electrical connections should be tight and in good condition to prevent losses through loose or corroded connections.
- Ethylene-glycol-base antifreeze is recommended. An inhibitor system is included in this type of antifreeze and the corrosion protection is sufficient as long as the recommended concentration range of 30 to 67 percent (antifreeze to water by volume) is employed.
- If the engine is to be operated in arctic temperatures, consult the nearest Sterling dealer or an authorized Detroit Diesel engine dealer for information regarding availability of special cold-weather equipment.

## Mercedes-Benz

For service products to use in cold weather, see **Chapter 5** of the *MBE4000 Engine Operator's Manual*.

# Engines and Clutches

---

If the engine is well maintained, no difficulties should be encountered when starting the engine under normal winter conditions. The engine will start unaided at temperatures above  $-4^{\circ}\text{F}$  ( $-20^{\circ}\text{C}$ ).

It is not necessary to press the accelerator pedal during starting. The Mercedes-Benz engine electronic system automatically delivers the correct amount of fuel for ignition, depending on the ambient temperature.

The intake air preheater is activated by turning the ignition switch to the on position. If the engine is at normal temperature, the INTAKE HEATER indicator goes out after 2 seconds.

If the temperature is low enough to require the heater, the INTAKE HEATER indicator stays on while the intake air preheater warms up. After the indicator goes out, start the engine. If the engine doesn't start after about 30 seconds of cranking, turn the key to the off position and wait 2 minutes; then repeat the starting procedure.

**NOTE:** If the engine doesn't start on the second try, wait at least 5 minutes before using the intake air preheater again.

**IMPORTANT:** In areas where the outside temperatures frequently fall below  $-4^{\circ}\text{F}$  ( $-20^{\circ}\text{C}$ ), a coolant preheater is recommended.

1. Periodically check the coolant mixing ratio (concentration of antifreeze in the coolant). Add more if necessary. The coolant mixing ratio should never rise above 60 percent antifreeze.
2. Use low-viscosity lubricating oils for adequate lubrication.
3. At temperatures below  $32^{\circ}\text{F}$  ( $0^{\circ}\text{C}$ ), do not use summer-grade (2-D) diesel fuel. To avoid fuel problems due to paraffin separation, use winter-grade (1-D or winterized 2-D) diesel fuel only.
4. If the use of unblended summer-grade diesel fuel in winter cannot be avoided, install a thermostatically controlled fuel heater to prevent wax from clogging the fuel filters, and formation of ice crystals from water in the fuel. If a fuel heater is used, make sure it has thermostatic controls to prevent excessive heating of the fuel in warm weather. Excessive heating of fuel can cause a loss of engine power.

## Engine Break-In, CAT, Cummins, DDE S60, M-B

Every engine is tested on a dynamometer before shipment, eliminating the need for a break-in period. Before running the engine for the first time, follow the instructions in the engine operator's manual.

## Engine Operation, CAT, Cummins, DDE S60, M-B



**Do not operate the engine in an area where flammable vapors such as gasoline or diesel fumes are present. Shut down the engine when in an area where flammable liquids or gases are being handled. Failure to observe these precautions could result in serious injury or death.**

All diesel engines have been built to comply with the requirements of the Federal (U.S.) Clean Air Act. Once an engine is placed in service, the responsibility for meeting both state and local regulations is with the owner/operator. Good operating practices, regular maintenance, and correct adjustments are factors that will help to stay within the regulations. Proper maintenance of the engine, which is the responsibility of the owner/operator, is essential to keep the emission levels low.

## Engine Protection

On electronic engines, an engine-protection system monitors all engine sensors and electronic components, and recognizes system malfunctions. If a critical fault is detected, an amber check-engine warning lamp and a red stop-engine lamp illuminate.

The standard parameters that are monitored for engine protection are: low coolant level, high coolant temperature, low oil pressure, high soot level in the DPF, and uncontrolled DPF regeneration.

## Amber Check-Engine Warning Lamp

When the amber check-engine warning lamp comes on for any reason, the vehicle can still be operated, allowing the driver to proceed to the required destination. This condition should be reported to an authorized service center as soon as possible.

## Red Stop-Engine Lamp



When the red stop-engine light illuminates, most engines are programmed to shut down automatically within 30 seconds. The driver must immediately move the vehicle to a safe location at the side of the road to prevent causing a hazardous situation that could cause bodily injury, property damage, or severe damage to the engine.

The red stop-engine lamp illuminates to indicate that the engine-protection system has been activated. The conditions that will cause the red stop-engine lamp to come on are:

- high coolant temperature
- loss of coolant
- low oil pressure
- high soot level (DPF)
- uncontrolled DPF regeneration

On some engines, the engine ECU will derate the engine, allowing it to run at low rpm and slow vehicle speed, until the vehicle can be driven to a safe location or to a service facility. On other engines, the engine ECU will first derate the engine, then if the condition does not improve, shut it down completely 30 seconds after the light comes on. The driver must safely bring the vehicle to a stop on the side of the road before the engine shuts down.

To restart the engine (override the shutdown command) turn the ignition switch to OFF, leave it there a few seconds, and turn the switch to START. The engine will run for a short period and shut down again if the condition does not improve.

**IMPORTANT:** Do not attempt to restart the engine while the vehicle is moving. Bring the vehicle to a safe stop and restart the engine with the vehicle stopped.

## Stop-Engine Override Switch

If the vehicle is equipped with a stop-engine override (SEO) switch, it can be used to override the shutdown sequence. This override resets the shutdown timer, restoring power to the previous level before the red stop-engine lamp was illuminated. The switch

must be recycled after five seconds to obtain a subsequent override.



Using the override button so the engine operates for an extended period may result in engine damage. The operator has the responsibility to take action to avoid engine damage.

## Caterpillar Engine Operation

Proper operation and maintenance are key factors in obtaining the maximum life and economy of an engine. Follow the directions in the Caterpillar *Operation and Maintenance Management Manual* and this manual, for trouble-free, economical engine operation.

1. Operate the engine at low load. After normal oil pressure is reached and the temperature gauge begins to move, the engine may be operated at full load.

Caterpillar electronic engines automatically idle at 900 to 1000 rpm for the correct warm-up time after a cold engine start at lower than 40°F (5°C). These electronic engine systems will reduce the idle speed to 600 rpm when the engine is warm enough to drive the vehicle.

**IMPORTANT:** Fuel heaters used on vehicles with Caterpillar electronic engines could cause excessive fuel temperatures that affect engine performance and operation of the electronic engine controls. If a fuel heater is used, make sure it has thermostatic controls. If the fuel heater has a timer, set the timer to activate only for a limited period of time before the engine starts. Make sure the fuel heater is used only for starting the engine.

2. Select a gear that allows a smooth, easy start without increasing engine speed above low idle or slipping the clutch. Engage the clutch smoothly. Jerky starts waste fuel and put stress on the drivetrain.

It is not necessary to accelerate Caterpillar electronic engines to governed speed in the lower gears to get the vehicle moving except in a high power demand situation such as starting on a grade.

# Engines and Clutches

---

3. Continue to upshift until cruising speed is reached. Use only the rpm needed to make an upshift into the next gear. The engine speed needed to make an upshift increases as the vehicle speed increases or if upshifts are made on uphill grades. If the vehicle can be operated in a higher gear after reaching the desired speed, select the highest gear available that will pull the load. Experience with your vehicle will show you what rpm is needed to make upshifts under various conditions. This "progressive shifting" technique will lower fuel costs because the engine will be operating at the lowest rpm needed to pull the load.

Caterpillar electronic engines can be programmed to limit engine rpm while the vehicle is operated in the lower and higher gears. This feature assists the driver in following "progressive shifting" techniques.

4. On uphill grades, begin downshifting when the engine rpm falls to 1200 rpm for C-10, C-12, and 3406E electronic engines. Fuel economy will be best if you let the engine lug back to around this speed before you downshift. Downshift until a gear is reached in which the engine will pull the load. Let the engine lug down if you can make it to the top of a hill without downshifting.

**IMPORTANT:** Don't let C-10, C-12, and 3406E electronic engines exceed 2300 rpm (2100 rpm if equipped with an exhaust brake).

5. On a downhill grade, do not coast or put the transmission in neutral. Select the correct gear that does not allow the engine to exceed its maximum speed. Use the brakes to limit the vehicle speed.

A simple rule to follow is to select the same gear (or one gear lower) that would be needed to go up the grade.

6. As with any engine, prolonged idling of Caterpillar engines is not recommended. An idling engine wastes fuel and if left unattended, is also unsafe.

Caterpillar engines can be programmed to shut off automatically after a specified idling time. The vehicle transmission must be in neutral and the parking brake must be set for the automatic shut-off option to work.

## Power Takeoff (PTO) Governor

Caterpillar electronic engines may be equipped with a PTO governor. This mode is used only when the vehicle is parked. The PTO mode is activated by the On/Off and SET/RESUME switches.

1. To engage the PTO:
  - 1.1 Flip the On/Off switch on the instrument control panel to On.
  - 1.2 Hold the throttle down until the tachometer reaches the desired engine speed.
  - 1.3 Momentarily move the SET/RESUME switch on the instrument control panel to Set or push the Set button on the transmission shift knob.
2. To disengage the PTO:
  - 2.1 Depress the brake pedal or clutch pedal, *or*
  - 2.2 Flip the On/Off switch on the instrument control panel to Off or press the PAUSE button on the shift knob.
3. To resume a previously selected engine speed:
  - 3.1 If the On/Off switch on the instrument control panel is in the Off position, flip it to On.
  - 3.2 Momentarily move the SET/RESUME switch on the instrument control panel to RESUME or press the RESUME button on the transmission shift knob.

To adjust engine speed up or down, hold the SET/RESUME switch on the instrument control panel at SET to accelerate or at RESUME to decelerate until the desired speed is reached; or, press the SET button on the transmission shift knob to accelerate or the RESUME button to decelerate until the desired speed is reached.

**NOTE:** The resume engine speed memory is not maintained if the ignition is shut off.

## Cummins Engine Operation

Cummins diesel engines have been built by Cummins to comply with the requirements of the Federal (U.S.) Clean Air Act. Once the engine is placed in service, the responsibility for meeting both state and



# Engines and Clutches

---

local regulations is with the owner/operator. Good operating practices, regular maintenance, and proper adjustments are factors which will help to stay within the regulations.

Proper maintenance of the engine, which is the responsibility of the owner/operator, is essential to keep the emission levels low.

Follow the directions in the Cummins *Operation and Maintenance Manual* and this manual for trouble-free, economical vehicle engine operation.

1. Cummins diesel engines produce high horsepower and peak torque characteristics at lower rpm. Because of this, it is not necessary to keep the engine "wound up" to deliver the required horsepower at the wheels. These characteristics may also result in less shifting and make shifting at lower rpm (toward peak torque) more practical.
2. Depending on the vehicle gearing, the posted speed limit can sometimes allow operation in either of the top two gears; however, for improved operating efficiency (fuel economy and engine life), operate in the top gear at reduced rpm rather than in the next lower gear at the maximum rpm.
3. Cruise at partial throttle whenever road conditions and speed requirements permit. This driving technique permits operating within the most economical power range of the engine.
4. When approaching a hill, open the throttle smoothly to start the upgrade at full power, then shift down as desired to maintain the maximum vehicle speed. The higher torque of Cummins engines may permit topping some grades without shifting.
5. Cummins engines are designed to operate over a wide speed range. More frequent shifting than necessary does not allow proper utilization of this flexibility. The driver who stays in top gear and uses the wider speed range will achieve the best fuel economy.
6. The Cummins diesel engine is effective as a brake on downhill grades, but care must be used not to overspeed the engine going downhill. The governor has no control over engine speed when it is being pushed by the loaded vehicle.

Never turn off the ignition switch while going downhill. With the engine still in gear, fuel pres-

sure will build up against the shutdown valve and may prevent it from opening when the ignition key is turned on.

---

## CAUTION

---

**Engine overspeed (engine speed exceeds high idle, no-load rpm) can damage the engine.**

7. Use a combination of brakes and gears to keep the vehicle under control at all times and to keep the engine speed below the rated governed rpm.

### Power Takeoff (PTO) Governor

Cummins electronic engines may be equipped with a PTO governor. This mode is used only when the vehicle is parked. The PTO mode is activated by the On/Off and SET/RESUME switches.

1. To engage the PTO:
    - 1.1 Flip the On/Off switch on the instrument control panel to On.
    - 1.2 Hold the throttle down until the tachometer reaches the desired engine speed.
    - 1.3 Momentarily move the SET/RESUME switch on the instrument control panel to SET or push the SET button on the transmission shift knob.
- IMPORTANT:** Two PTO engine speeds can be preset on CELECT Plus engines. With the On/Off switch on, move the SET/RESUME switch to SET to reach the first preset value or move the switch to RESUME for the second preset value. After one preset value has been selected, you must turn the On/Off switch off then turn it back on before using the second preset value.
2. To disengage the PTO:
    - 2.1 Depress the brake pedal, clutch pedal, throttle pedal (CELECT Plus engines only), *or*
    - 2.2 Flip the On/Off switch on the instrument control panel to Off or press the PAUSE button on the shift knob.
  3. To resume a previously selected engine speed:

# Engines and Clutches

- 3.1 If the On/Off switch on the instrument control panel is in the Off position, flip it to On.
- 3.2 Momentarily move the SET/RESUME switch on the instrument control panel to RESUME or press the RESUME button on the transmission shift knob.

To adjust engine speed up or down, hold the SET/RESUME switch on the instrument control panel at SET to accelerate or at RESUME to decelerate until the desired speed is reached, or press the SET button on the transmission shift knob to accelerate or the RESUME button to decelerate until the desired speed is reached.

NOTE: The resume engine speed memory is not maintained if the cruise control On/Off switch is turned Off or if the ignition is shut off.

## Detroit Diesel S60 Engine Operation

Individual driving habits can make a difference in the performance and economy of any engine. The recommendations that follow call attention to the techniques that can be employed to save fuel and extend the operating efficiency and life of a new Detroit Diesel engine for the longest possible time.

All engines have an operating range in which the engine performs most efficiently. The operating range extends from maximum torque rpm at the low end to engine rated speed at the high end. Detroit Diesel engines deliver best fuel economy when operated in the low- and mid-speed segments of the efficiency range and produce maximum horsepower at rated speed, which is also the recommended maximum speed of the engine.

1. It is seldom necessary to accelerate the engine to governed speed in the lower gears to get the vehicle moving, except in a high power demand situation such as starting on a grade.

To conserve fuel, start off in low gear and develop only the engine speed needed to get rolling. Then increase engine speed gradually as upward gear shifting progresses.

As described by Detroit Diesel, this "progressive shifting" technique will get the vehicle up to the desired cruising speed while minimizing noise emission and maximizing fuel economy. A progressive shift pattern is illustrated in [Fig. 7.6](#).

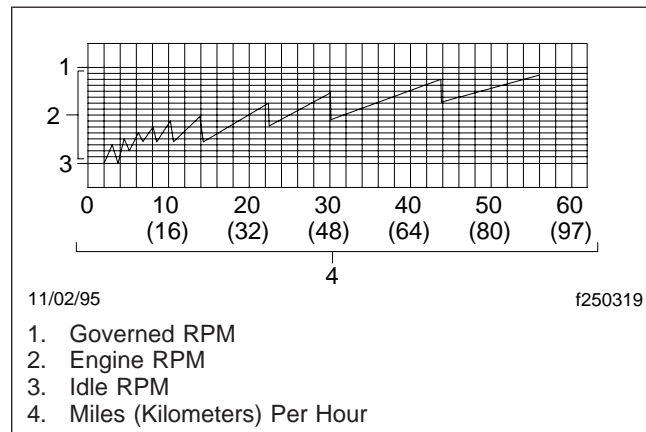


Fig. 7.6, Progressive Shift Pattern

NOTE: A momentary hesitation in throttle response will occur when a vehicle with a turbo-charged engine is started on a grade. *Do not* disengage the clutch. The rpm will recover and the vehicle will accelerate up the grade.

2. For city driving, run in the highest gear possible and reduce engine speed. This enables you to operate at a safe speed for traffic conditions while using less fuel and reducing noise. Also, when slowing down for reduced speed zones, remain in your running gear and reduce engine rpm to stay within the speed limit. Avoid downshifting until you are ready to return to highway cruising speed.
3. For highway cruising and for best fuel economy, run the engine at 80 to 90 percent of rated rpm to maintain highway speed. Engines with 1800 rpm ratings are exceptions and will provide fuel economy when run at their rated speed. Proper gear selection should permit cruising in the economy range with no appreciable sacrifice in desired highway speed.

It is okay to operate below rated rpm at full throttle if you are satisfied with the way the vehicle performs. However, there are times when hilly terrain, high winds, or other conditions make it impractical to operate without reserve power. Such conditions are better met if the vehicle is operated in a lower gear with reserve power available for changes in terrain, wind, etc.

4. The proper use of gears will shorten time on hills and minimize the amount of shifting. When starting up a hill, gradually depress the accelerator

pedal all the way and keep it there as the vehicle moves up the grade. If the engine continues to maintain a satisfactory road speed, remain in that gear for the entire grade.

If the hill causes a steady decline in engine rpm, downshift as required until the engine can maintain a stable uphill speed. Make full use of each gear before going to a lower gear. By remaining in a gear until arriving at the speed of the next lower gear, the vehicle will top the grade in the best possible time on less fuel and fewer shifts.

5. Because of their constant torque over a wide speed range, Detroit Diesel engines can be operated at full throttle at lower rpm than other engines. This offers benefits in fuel economy and engine life. And more than likely it will be possible to top most grades without downshifting.

When the vehicle starts into a grade, allow the engine to lug down to maximum torque rpm before downshifting. Downshift, if required, at maximum torque rpm also, or at the predetermined road speed for the next lower gear.

Do not be afraid to lug the engine down. It has more than enough torque at low rpm to keep a loaded vehicle moving against a grade and it won't harm the engine.

6. The driver who is not familiar with the vehicle's shift points can greatly improve driving skill by learning them for all gears. By knowing rather than guessing where the shift points are, it is possible to avoid overspeeding the engine by downshifting too soon or missing the full use of a gear by downshifting too late. The shift points of any vehicle can be determined by a simple road-test method. Run the vehicle and determine the maximum road speed possible in every gear at the engine governed full-load speed setting.

The top road speed possible in a gear would be the shift point for that gear. The results should be recorded in the proper order of shifting and displayed inside the cab.

---

## CAUTION

---

**Do not allow the engine to exceed its governed speed, or serious engine damage could result.**

7. To slow the vehicle on downgrades and curves (using the engine), shift to a lower gear and allow the vehicle to decelerate in that gear. The

engine provides maximum braking effect when running at the top end of the operating range, but it must not be allowed to exceed its full-load rated rpm. Continue to downshift as further reduction in vehicle speed is required. If the vehicle is above the allowable maximum speed of a lower gear, use the service brakes to slow the vehicle to an acceptable speed where the transmission may be downshifted safely. Again, the importance of knowing the shift points is demonstrated.

**IMPORTANT:** The engine governor has no control over engine rpm when the engine is being pushed by a loaded vehicle down a grade. Use service brakes and gears in combination on long grades to keep the vehicle speed under control and the engine rpm below full-load rated governed speed.

8. Essential information regarding the operation and care of Allison automatic transmissions is contained in the Allison *Driver's Handbook*. Applying the knowledge presented will not only make driving easier, but will give the maximum benefits from an Allison-equipped vehicle.

Maintenance literature is also available for drivers of Allison-equipped vehicles who desire trouble-free performance and maximum life from their equipment. These maintenance books are available from any authorized Detroit Diesel engine distributor.

9. As with all engines, prolonged idling of Detroit Diesel engines is not recommended. An idling engine wastes fuel and left unattended, is also unsafe.

A Detroit Diesel Electronic Control (DDEC) engine can be equipped to shut off automatically after 5 minutes of idling. The vehicle transmission must be in neutral and the parking brake must be set for the automatic shutoff option to work. To start the engine, follow the normal start-up procedure.

Engines equipped with DDEC will idle fast when cold. As the engine warms up to operating temperature, the idle speed will decrease. Warm the engine until idle speed is normal before operating the vehicle.

# Engines and Clutches

---

## Power Takeoff (PTO)

A power takeoff option is available for vehicles equipped with a DDEC system. The PTO operates only when the vehicle is at a standstill.

Some vehicles have separate controls for the PTO. In the case of a preset nonadjustable PTO engine speed, there is only an on/off switch labeled FAST IDLE. If the vehicle is equipped with a variable PTO engine speed, there are two controls: an on/off switch, and a potentiometer knob. Both of these are labeled GOVERNOR.

On other vehicles, the PTO mode is activated by the On/Off and SET/RESUME cruise control switches.

### *Operating the PTO With Separate PTO Controls*

1. Set the parking brake.
2. Turn on the switch labeled GOVERNOR (or FAST IDLE for vehicles with a preset PTO system).
3. For vehicles with a variable PTO, use the potentiometer knob to adjust the engine rpm.

### *Operating the PTO Using Cruise Control Switches*

1. To engage the PTO:
  - 1.1 Flip the On/Off switch on the instrument control panel to On.
  - 1.2 Hold the throttle down until the tachometer indicates the desired engine speed.
  - 1.3 Momentarily move the SET/RESUME switch on the instrument control panel to SET or push the SET button on the transmission shift knob.
2. To disengage the PTO:
  - 2.1 Depress the brake pedal, clutch pedal, or
  - 2.2 Flip the On/Off switch on the instrument control panel to Off or press the PAUSE button on the shift knob.
3. To resume a previously selected engine speed:
  - 3.1 If the On/Off switch on the instrument control panel is in the Off position, flip it to On.

- 3.2 Momentarily move the SET/RESUME switch on the instrument control panel to RESUME or press the RESUME button on the transmission shift knob.

To adjust engine speed up or down, hold the SET/RESUME switch on the instrument control panel at SET to accelerate or at RESUME to decelerate until the desired speed is reached, or press the SET button on the transmission shift knob to accelerate or the RESUME button to decelerate until the desired speed is reached.

## Mercedes-Benz Engine Operation

Individual driving habits can make a difference in the performance and economy of any engine. The recommendations below call attention to the techniques that can be employed to save fuel and extend the operating efficiency and life of a new Mercedes-Benz engine for the longest possible time.

Engines with electronic controls can be equipped with a variety of options designed to warn the operator of engine problems. The operator of an electronically controlled engine should know the extent of the warning system in order to bring the vehicle to a safe stop if the engine malfunctions. If the operator doesn't understand how the system works, an engine shutdown could cause a safety hazard. See [Chapter 2](#) for information on the control panels.

All engines have an operating range in which the engine performs most efficiently. The operating range extends from maximum torque rpm at the low end to engine rated speed at the high end. Mercedes-Benz engines deliver best fuel economy when operated in the low- and mid-speed segments of the efficiency range and produce maximum horsepower at rated speed, which is also the recommended maximum speed of the engine.

The maximum speed in regular operation is 2000 rpm. However, during engine braking only, a higher rpm can be used to increase retarding power if necessary. In engine braking conditions, the engine can be operated up to, but not exceeding 2500 rpm.

1. It is seldom necessary to accelerate the engine to governed speed in the lower gears to get the vehicle moving, except in a high power demand situation such as starting on a grade.

# Engines and Clutches

---

To conserve fuel, start off in low gear and develop only the engine speed needed to get rolling. Then increase engine speed gradually as upward gear shifting progresses.

This "progressive shifting" technique will get the vehicle up to the desired cruising speed while minimizing noise emission and maximizing fuel economy.

**NOTE:** A momentary hesitation in throttle response will occur when a vehicle with a turbocharged engine is started on a grade. *Do not* disengage the clutch. The rpm will recover and the vehicle will accelerate up the grade.

2. For city driving, run in the highest gear possible and reduce engine speed. This enables you to operate at a safe speed for traffic conditions while using less fuel and reducing noise. Also, when slowing down for reduced speed zones, remain in your running gear and reduce engine rpm to stay within the speed limit. Avoid downshifting until you are ready to return to highway cruising speed.

3. For highway cruising and for best fuel economy, run the engine at 1300 to 1500 rpm to maintain highway speed. Proper gear selection should permit cruising in the economy range with no appreciable sacrifice in desired highway speed.

It is recommended that you operate at a lower rpm if you are satisfied with the way the vehicle performs. However, there are times when hilly terrain, high winds, or other conditions make it impractical to operate without reserve power. Such conditions are better met if the vehicle is operated in a lower gear with reserve power available for changes in terrain, wind, etc.

4. The proper use of gears will shorten time on hills and minimize the amount of shifting. When starting up a hill, gradually depress the accelerator pedal all the way and keep it there as the vehicle moves up the grade. If the engine continues to maintain a satisfactory road speed, remain in that gear for the entire grade.

If the hill causes a steady decline in engine rpm, downshift as required until the engine can maintain a stable uphill speed. Make full use of each gear before going to a lower gear. By remaining in a gear until arriving at the speed of the next

lower gear, the vehicle will top the grade in the best possible time on less fuel and fewer shifts.

5. Because of their high torque on the low end, Mercedes-Benz engines can be operated at full throttle at lower rpm than other engines. This offers benefits in fuel economy and engine life. And more than likely it will be possible to top most grades without downshifting.

When the vehicle starts into a grade, allow the engine to lug down to maximum torque rpm before downshifting. Downshift, if required, at maximum torque rpm also or at the predetermined road speed for the next lower gear.

Do not be afraid to lug the engine down. It has more than enough torque at low rpm to keep a loaded vehicle moving against a grade and it won't harm the engine.

6. The driver who is not familiar with the vehicle's shift points can greatly improve driving skill by learning them for all gears. By knowing rather than guessing where the shift points are, it is possible to avoid overspeeding the engine by downshifting too soon or missing the full use of a gear by downshifting too late. The shift points of any vehicle can be determined by a simple road-test method. Run the vehicle and determine the maximum road speed possible in every gear at the engine governed full-load speed setting.

The top road speed possible in a gear would be the shift point for that gear. The results should be recorded in the proper order of shifting and displayed inside the cab.

**NOTE:** In regular operation, the engine speed does not exceed the rated speed of 2000 rpm.

7. To slow the vehicle on downgrades, shift to a lower gear and apply the engine brake. Continue to downshift as further reduction in vehicle speed is required. If the vehicle is above the allowable maximum speed of a lower gear, use the service brakes to slow the vehicle to an acceptable speed where the transmission may be downshifted safely. Again, the importance of knowing the shift points is demonstrated.

**IMPORTANT:** The engine governor has no control over engine rpm when the engine is being pushed by a loaded vehicle down a grade. When using the engine brake it is recommended to use engine speeds up to 2300 rpm.

# Engines and Clutches

---

The engine provides maximum braking effect when running at 2500 rpm, but it must not be allowed to exceed this speed.

## CAUTION

**Do not allow the engine to exceed 2500 rpm. Serious engine damage could result.**

8. Essential information regarding the operation and care of Allison automatic transmissions is contained in the Allison *Driver's Handbook*. Applying the knowledge presented will not only make driving easier, but will give the maximum benefits from an Allison-equipped vehicle.

Maintenance literature is also available for drivers of Allison-equipped vehicles who desire trouble-free performance and maximum life from their equipment. These maintenance books are available from any authorized Detroit Diesel engine distributor.

9. As with all engines, prolonged idling of Mercedes-Benz engines is not recommended. An idling engine wastes fuel, and, left unattended, is also unsafe.

## Power Takeoff (PTO)

A power takeoff option is available for vehicles equipped with an electronically controlled operating system. Normally, the PTO operates only when the vehicle is at a standstill.

Some vehicles have separate controls for the PTO. In the case of a preset nonadjustable PTO engine speed, there is only an on/off switch labeled FAST IDLE. If the vehicle is equipped with a variable PTO engine speed, there are two controls: an on/off switch, and a potentiometer knob. Both of these are labeled GOVERNOR.

On other vehicles, the PTO mode is activated by the On/Off and SET/RESUME cruise control switches.

### *Operating the PTO With Separate PTO Controls*

1. Set the parking brake.
2. Turn on the switch labeled GOVERNOR (or FAST IDLE for vehicles with a preset PTO system).

3. For vehicles with a variable PTO, use the potentiometer knob to adjust the engine rpm.

### *Operating the PTO Using Cruise Control Switches*

1. To engage the PTO:
  - 1.1 Flip the On/Off switch on the instrument control panel to On.
  - 1.2 Hold the throttle down until the tachometer indicates the desired engine speed.
  - 1.3 Momentarily move the SET/RESUME switch on the instrument control panel to SET or push the SET button on the transmission shift knob.
2. To disengage the PTO:
  - 2.1 Depress the brake pedal, clutch pedal, or
  - 2.2 Flip the On/Off switch on the instrument control panel to Off or press the PAUSE button on the shift knob.
3. To resume a previously selected engine speed:
  - 3.1 If the On/Off switch on the instrument control panel is in the Off position, flip it to On.
  - 3.2 Momentarily move the SET/RESUME switch on the instrument control panel to RESUME or press the RESUME button on the transmission shift knob.

To adjust engine speed up or down, hold the SET/RESUME switch on the instrument control panel at SET to accelerate or at RESUME to decelerate until the desired speed is reached, or press the SET button on the transmission shift knob to accelerate or the RESUME button to decelerate until the desired speed is reached.

## Engine Shutdown, CAT, Cummins, DDE S60, M-B Caterpillar

## CAUTION

**Stopping the engine immediately after it has been working under load can result in overheating and**

**accelerated wear of the engine components. Excessive temperatures in the turbocharger center-housing will cause oil coking problems. Follow the procedure, outlined below, to allow the engine to cool.**

1. With the vehicle stopped, apply the parking brakes. Reduce the engine speed to low idle.
2. Place the transmission shift lever in neutral.

**NOTE:** If the engine has been operating at low loads, run it at low idle for 30 seconds before stopping. If the engine has been operating at highway speed or at high loads, run it at low idle for 3 minutes to reduce and stabilize internal engine temperatures before stopping.

3. Check the crankcase oil level while the engine is stopped. Maintain the oil level between the add and full marks on the dipstick.
4. Turn off the ignition key to shut down the engine.
5. If equipped with an idle shutdown timer, it can be set to shut the engine down after a preset amount of time. Ninety seconds before the preset shutdown time, the "check engine" light will begin to flash at a rapid rate. If the clutch pedal or service brake indicate a position change during this final ninety seconds, (diagnostic lamp flashing), the idle shutdown timer will be disabled until reset.
6. After stopping the engine, fill the fuel tank.
7. If freezing temperatures are expected, allow the engine jacket water expansion tank to cool, then check the coolant for proper antifreeze protection. The cooling system must be protected against freezing to the lowest expected outside temperature. Add permanent-type antifreeze if required.
8. Repair any leaks, perform minor adjustments, tighten loose bolts, etc. Observe the vehicle mileage or the service meter reading, if so equipped. Perform periodic maintenance as instructed in the Lubrication and Maintenance Chart in the Caterpillar *Operation and Maintenance Management* manual.

## Cummins

1. With the vehicle stopped, apply the parking brakes and place the transmission in neutral.

2. It is important to idle an engine 3 to 5 minutes before shutting it down. This allows the lubricating oil and the water to carry heat away from the combustion chamber, bearings, shafts, etc. This is especially important with turbocharged engines.

Bearings and seals in the turbocharger are subjected to the high heat of combustion exhaust gases. While the engine is running, this heat is carried away by oil circulation, but if the engine is stopped suddenly, the turbocharger temperature may rise as much as 100°F (56°C). The extreme heat may cause bearings to seize or oil seals to leak.

3. Do not idle the engine for excessively long periods. Long periods of idling are not good for an engine because the combustion chamber temperatures drop so low the fuel may not burn completely. This will cause carbon to clog the injector spray holes and piston rings, and may result in stuck valves.

If the engine coolant temperature becomes too low, raw fuel will wash the lubricating oil off the cylinder walls and dilute the crankcase oil; therefore, all moving parts of the engine will suffer from poor lubrication.

4. If the engine is not being used, shut it down by turning the ignition key off.

---

## CAUTION

---

**Stop the engine at the first sign of malfunction. Almost all malfunctions give some warning to the operator before significant damage occurs. Many engines are saved because alert operators heed the warning signs (sudden drop in oil pressure, unusual noises, etc.) and immediately shut down the engine.**

## Detroit Diesel S60

1. With the vehicle stopped, apply the parking brakes and place the transmission in neutral.
2. Allow the engine to run at half speed or slower with no load for 4 to 5 minutes to cool the engine gradually and uniformly.
3. Shut down the engine by turning the ignition key off.

# Engines and Clutches

---

## Mercedes-Benz

1. With the vehicle stopped, apply the parking brakes and put the transmission in neutral.
2. Allow the engine to idle for 1 to 2 minutes before shutting it down.
3. Shut down the engine by turning off the ignition.

## High-Altitude Operation, CAT, Cummins, DDE S60, M-B

### Caterpillar

Maximum turbocharger speed is determined by the rack setting, the high idle speed setting, and the altitude at which the engine is operated. The high idle speed and the rack setting are not the same for all altitudes; they have been established to permit the engine to be operated at the altitude marked on the engine information plate.



### CAUTION

**If the high idle speed or the rack setting is greater than specified for the altitude at which the engine is operated, damage to engine or turbocharger parts can result.**

The fuel pump rack has been set by qualified personnel for a particular engine application. The governor housing and turbocharger are sealed to prevent unqualified personnel from tampering with the adjustments.

The engine can be operated at a lower altitude than specified without danger of engine damage. In this situation the engine will perform at slightly less than maximum efficiency. When operated at a higher altitude, the rack setting and high idle speed setting must be changed. These settings should be made only by an authorized Caterpillar engine dealer. The adjustments can be made by reprogramming the personality module in the ECM.

## Cummins

Engines lose horsepower when operated at high altitude because the air is too thin to burn as much fuel as at sea level. This loss is about 3 percent for each 1000 feet (300 m) altitude above sea level for a naturally aspirated engine. Most turbocharged engines

are rated for higher altitudes than naturally aspirated engines.

An engine will have smoky exhaust at high altitudes unless a lower gear is used. The engine will not demand full fuel from the fuel system unless the engine is altitude-compensated by the use of a turbocharger. Shift gears as needed to avoid excessive exhaust smoke.

## DDE S60, Mercedes-Benz

There is no restriction with respect to altitude operation. MBE4000 engines perform properly between sea level and 13,000 feet (4000 m) above sea level.

## Engine Braking System, CAT, Cummins, DDE S60, M-B

### CAT BrakeSaver

The BrakeSaver (optional on 3406E engines) permits the operator to control the speed reduction of the vehicle on grades, curves, or anytime speed reduction is necessary but long applications of the service brakes are not desired.

During downhill operation, the crankshaft is turned by the rear wheels (through the drivetrain). To reduce the speed of the vehicle, an application of braking force can be made to the crankshaft. The BrakeSaver does this by converting rotation energy into heat which is removed by the engine cooling system. The BrakeSaver is controlled by the driver as necessary, by operating a lever on the instrument panel. Braking force increases as the lever is moved toward the ON position. An air pressure gauge provides a relative indication of the braking force. An oil temperature gauge indicates the heat in the BrakeSaver during its operation. If the temperature gauge indicates HOT, the BrakeSaver control lever must be moved to the OFF position. The oil temperature will decrease rapidly with the BrakeSaver off. When the temperature reaches normal, the BrakeSaver can be used.



### CAUTION

**Do not engage the BrakeSaver and control the wheel speed with the accelerator. The design of the cooling system is for the control of the temperature of the oil at full engine power or full**



**BrakeSaver capacity, but not both at the same time.**

## Exhaust Brake

An exhaust brake is an optional auxiliary braking system that assists but does not replace the primary service brake system. An on/off instrument panel switch in combination with the accelerator and clutch pedal switches allows the operator to make maximum use of the exhaust brake in off-highway and mountain driving as well as in traffic or high speed highway driving. It is not available with automatic transmissions.

The exhaust brake is a butterfly-type valve mounted in the exhaust pipe. When the operator's foot is not on the accelerator pedal and the exhaust brake switch is in the ON position, an air cylinder shuts the butterfly valve restricting the flow of exhaust gases and retarding the engine. This retarding action is carried through the engine and drivetrain, slowing the vehicle and reducing the need for frequent service brake applications.

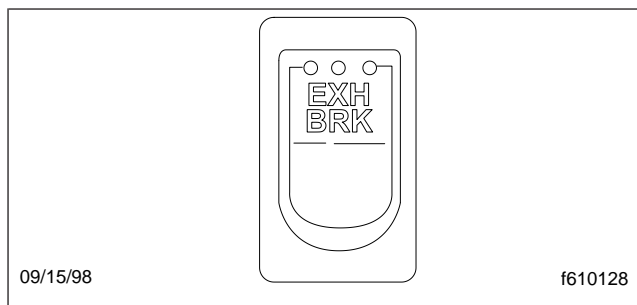
Exhaust brakes are not intended for use as the primary braking system during vehicle operation.

## Operation

Before starting the engine, make sure that the exhaust brake switch is in the OFF position. Do not turn the exhaust brake on until the engine has reached normal operating temperatures.

Push the exhaust brake switch up to turn the exhaust brake on. Push the switch again to turn the brake off. See [Fig. 7.7](#).

Make sure the exhaust brake is turned off before shutting off the engine.



**Fig. 7.7, Exhaust Brake Switch**

## Driving Downhill

While approaching a steep grade, make sure that the exhaust brake switch is in the ON position. The exhaust brake actuates as soon as you remove your foot from the accelerator pedal. While going down the grade, use a low enough gear to safely descend with a minimum application of the service brakes. As a general guideline, use the same gear as you would to ascend the hill.

### CAUTION

**Before descending a hill or steep grade always select the proper gear. If the transmission is taken out of gear while descending it is possible that you will not be able to select another gear because of maximum rpm being governed.**

Make sure the engine speed does not exceed the maximum allowable engine rpm. Exceeding the maximum engine rpm will result in damage to the engine. Apply the service brakes to reduce the engine rpm or make a slower descent by using a lower gear.

### CAUTION

**This device is not recommended for use on slippery or low-traction road surfaces. Under these conditions a loss of vehicle control could possibly occur.**

## Exhaust Brake Operating Characteristics

When you remove your feet from both the accelerator and clutch pedals and the actuator switch is in the ON position, the exhaust brake is activated. The following conditions should exist if the brake is operating properly:

- A slight change in the sound of the engine may be noticed when the exhaust brake is activated.
- Exhaust smoke should appear normal.
- Engine temperature should remain in the normal operating range.
- Road speed usually decreases when the exhaust brake is applied during a descent, except when the vehicle is carrying a heavy load or the grade is extremely steep. In these instances, you may need to apply the service brakes occasionally.

# Engines and Clutches

---

- Do not expect a retarding effect similar to sudden hard application of the service brakes. The exhaust brake retards the vehicle with a smooth braking effect.
- During a descent, the tachometer usually shows a drop in rpm depending on the grade and the vehicle load.
- Depending on the grade and vehicle load, you may or may not feel the retarding force acting against your body when the brake is applied. The brake's retarding force may not always be noticed, but it is actually preventing the vehicle from going much faster.

---

## CAUTION

---

**Installing an exhaust or auxiliary brake should never allow the engine to exceed maximum governed speeds under any conditions.**

### Jacobs Engine Brake

A Jacobs engine brake is a hydraulic-electric engine attachment that converts a diesel engine into an air compressor. This is done by changing engine exhaust valve operation. An engine brake is not a substitute for a service braking system, except in emergencies, because it does not provide the precise control available from the service brakes.

The Jake Brake is controlled by a single, dash-mounted paddle switch with three positions: OFF, LO, and HI.

### Jacobs Engine Brake Operation

## WARNING

**Do not use the engine brake if road surfaces are slippery. Using the engine brake on wet, icy, or snow-covered roads could result in loss of vehicle control, possibly causing personal injury and property damage.**

To engage the engine brake, the dash switch must be in the LO or HI position and both the clutch and throttle pedals must be fully released. To disengage the engine brake, depress the throttle or clutch pedal, or move the dash switch to OFF.

## WARNING

**The engine brake must be disengaged when shifting gears. The clutch must be used if the dash switch is in the LO or HI position. If the engine brake is engaged when the transmission is in neutral, the braking power of the engine brake can stall the engine, which could result in loss of vehicle control, possibly causing personal injury and property damage.**

Since the engine brake is most effective at rated engine speed, gear selection is very important. Gearing down the vehicle within the limits of the rated engine speed makes the engine brake more effective. Maximum braking occurs with the use of the lowest gear that does not exceed the rated engine speed. A rule of thumb for gear choice is to select the gear that normally would be used to climb an approaching downhill grade. Generally, this same gear can be used with the engine brake for a controlled descent of the hill.

"Control speed" is the speed at which the engine brake performs 100 percent of the required downhill braking, resulting in a constant speed of descent. The control speed varies, depending on vehicle weight and the downhill grade.

For faster descent, select a higher gear than that used for control speed. Service brakes must then be used intermittently to prevent engine overspeed and to maintain desired vehicle speed.

**IMPORTANT:** When descending a grade, remember that frequent use of service brakes causes them to become hot, which results in a reduction of their stopping ability. Grade descent speed should be such that the service brakes are used infrequently and that they remain cool, thus retaining their effectiveness.

A driver may descend slower than control speed by selecting a lower gear, one that will not overspeed the engine. The engine brake retarding force will then be sufficient to cause vehicle deceleration. Occasional deactivation of the engine brake may be necessary to maintain the designated road speed under these conditions.

The engine brake can be used to stop a vehicle if the service brakes quit working. By energizing the engine brake as soon as a service brake problem is apparent, a retarding effect is applied to the vehicle.

As grade conditions permit, the driver can progressively downshift using the engine brake in each gear. Eventually the engine brake will stop the vehicle.

## WARNING

**Using the engine brake as a primary braking system when the service brakes are operable is dangerous. This can cause long, unpredictable stopping distances, possibly resulting in personal injury or property damage.**

Whenever vehicle braking is required, the engine brake may be used with the service brakes. There is no time limit for operation of the engine brake.

1. After the engine is warmed up and the vehicle is in motion, move the paddle switch to the desired position, LO or HI. Depending on the engine model, LO will provide 1/3 or 1/2 of the full braking capacity of the engine. HI will provide maximum engine braking.
2. The engine brake activates when the dash switch is in LO or HI position and the driver's feet are removed from both the clutch and throttle pedals. If it fails to activate, stop the vehicle in a safe spot, and check the adjustment of the throttle and clutch switches. If no cause can be detected in the electrical system, check the engine brake system. Refer to the vehicle workshop manual for instructions.
3. To obtain maximum retarding, maintain the top governed speed of the engine through appropriate selection of gears when the engine brake is in use.
4. When either the clutch or throttle pedal is depressed, the engine brake is deactivated.

## CAUTION

**If the engine brake fails to shut off when either the throttle or clutch pedal is depressed, place the dash switch in the OFF position and do not use the engine brake until the throttle or clutch switch system is repaired. If the engine brake fails to shut off when the dash switch is turned off, the engine should be shut down and the engine brake repaired before continuing operation. Failure to do so could result in damage to the engine.**

## Turbo Brake (MBE4000 only)

For high braking output, the Mercedes-Benz MBE4000 engine can be equipped with an optional turbo brake.

The turbo brake can be operated either manually or automatically, through the cruise control function. If the turbo brake is operated manually, there is a four-position switch on the dashboard: *OFF/ LOW/ MED/ HIGH*.

The turbo brake provides 600 brake horsepower at 2500 engine rpm. In the braking condition the MBE4000 turbo brake engine operates as a turbo-charged compressor, resulting in high braking output. It is recommended to operate the turbo brake up to the 2300 rpm level. This provides approximately 550 brake horsepower which should cover most situations. If additional braking power is required, engine speed can be increased to 2500 rpm maximum, resulting in 600 brake horsepower.

## CAUTION

**Do not allow the engine to exceed 2500 rpm. Serious engine damage could result.**

Because the charge air pressure is maintained at a high level during braking, full throttle response is available immediately, if the operator desires it, without any turbo lag.

## CAUTION

**The turbo brake should only be operated when the engine coolant temperature exceeds 140°F (60°C). It cannot be engaged below this level. Be aware that no engine retarding system is available during engine warm-up.**

The MBE4000 turbo brake is combined with Mercedes-Benz constant throttle technology, but an exhaust flap is not used. The turbo brake emits very low levels of noise making it an environmentally friendly system. It is maintenance-free, highly reliable, and adds virtually no weight to the engine.

## Constant-Throttle Engine Brake (MBE4000 only)

The standard engine braking system is the constant-throttle system combined with an exhaust flap. To increase braking performance, each cylinder is

# Engines and Clutches

---

equipped with a small valve built into the cylinder head. This valve is always open during engine brake activation, and it allows compressed air to exhaust when the piston is at top dead center. This removes pressure from the piston as it moves to the bottom dead center position.

The standard constant-throttle engine brake is equipped with an exhaust flap. During engine brake operation, the six constant throttle valves are open in parallel and the exhaust flap is closed. For normal engine brake use, operate the engine up to 2300 rpm. If increased retarding power is required, the maximum 2500 engine rpm can be used.

---

## CAUTION

---

**Do not allow the engine to exceed 2500 rpm. Serious engine damage could result.**

A two-position switch on the dash controls the engine braking system. Like the exhaust flap, the constant throttles are deactivated when the accelerator or clutch pedal is depressed. The ABS system, when active, also deactivates constant-throttle braking.

## Clutches

### General Information

The major reason why clutches wear out too soon is excessive heat. Clutches are designed to absorb and dissipate more heat than encountered in typical operation. The temperatures developed in typical operation will not break down the clutch friction surfaces. However, if a clutch is slipped excessively or asked to do the job of a fluid coupling, high temperatures develop quickly and destroy the clutch. Temperatures generated between the flywheel, driven discs, and pressure plates can be high enough to cause the metal to flow and the friction facing material to char and burn.

Heat and wear are practically nonexistent when a clutch is fully engaged. But during the moment of engagement when the clutch is picking up the load, it generates considerable heat. An improperly adjusted or slipping clutch will rapidly generate sufficient heat to destroy itself.

The most important items that a driver should be aware of to ensure long service life of the clutch include: starting in the right gear, clutch malfunctions, and when to adjust a clutch.

## Clutch Operation

### Starting the Vehicle in the Proper Gear

An empty vehicle can be started in a higher transmission gear ratio than a partially or fully loaded vehicle. A good rule of thumb for the driver to follow is: select the gear combination that allows you to start moving with an idling engine, or if necessary, just enough throttle to prevent stalling the engine. After the clutch is fully engaged, the engine should be accelerated to the correct rpm for the upshift into the next higher gear.

### Gear Shifting Techniques

Many drivers upshift into the next gear, or even skip-shift into a higher gear, before the vehicle has reached the proper speed. This type of shifting is almost as bad as starting off in a gear that is too high, since the engine rpm and vehicle speeds are too far apart, requiring the clutch to absorb the speed difference with friction, creating heat. For transmission operating instructions, see [Chapter 8](#).

A clutch brake is installed on vehicles equipped with unsynchronized transmissions. The clutch brake is applied by fully depressing the clutch pedal. Its purpose is to stop the transmission gears from rotating in order to engage the transmission gears quickly in making an initial start.

---

## CAUTION

---

**Never apply the clutch brake when making downshifts or upshifts. The clutch pedal should never be fully depressed before the transmission is put in neutral. If the clutch brake is applied with the transmission still in gear, a reverse load will be put on the gear. At the same time, it will have the effect of trying to stop or decelerate the vehicle with the clutch brake. Rapid wear of the friction discs will take place necessitating frequent replacement. Considerable heat will be generated, which will be detrimental to the release bearings and transmission front bearings.**

### Excessive Vehicle Load, or Overloading the Clutch

Clutches are designed for specific vehicle applications and loads. These limitations should not be exceeded.

## CAUTION

**Overloading will not only result in damage to the clutch, but also to the entire powertrain.**

### **Riding the Clutch Pedal**

Riding the clutch pedal is very destructive to the clutch, since partial clutch engagement permits slippage, generating excessive heat. Riding the clutch pedal will also put a constant thrust load on the release bearing, which can thin out the lubricant. Release bearing failures can be attributed to this type of misuse.

### **Holding the Vehicle on an Incline With a Slipping Clutch**

A slipping clutch accumulates heat faster than it can be dissipated, resulting in early clutch failures. Never use the clutch as a hill holder.

### **Coasting With the Clutch Released (Pedal Depressed) and the Transmission in Gear**

Coasting with the clutch released and the transmission in gear can cause high driven disc rpm through multiplication of ratios from the final drive and transmission.

## WARNING

**Do not coast with the clutch released (pedal depressed) and the transmission in gear. High driven-disc rpm could cause the clutch facing to be thrown off the disc. Flying debris could cause injury to persons in the cab.**

### **Engaging the Clutch While Coasting**

Engaging the clutch while coasting can result in tremendous shock loads and possible damage to the clutch, as well as to the entire drivetrain.

### **Reporting Erratic Clutch Operation Promptly**

Reporting erratic clutch operation as soon as possible will give maintenance personnel a chance to inspect and lubricate the clutch components, make necessary internal clutch and linkage adjustments, etc.

Free pedal should be included and commented on daily in the driver's report, since clutch free pedal is the maintenance department's guide to the condition of the clutch and the release mechanism.

See **Group 25** of the *L-Line and A-Line Workshop Manual* for clutch adjustment procedures and specifications.

## CAUTION

**Operating the vehicle with incorrect free pedal could result in clutch damage.**

Clutch brake squeeze is an increased resistance (greater than the force of the clutch spring) felt as the clutch pedal approaches the end of its stroke. If the gears grind when shifting into first or reverse gear with the clutch pedal fully depressed, the clutch is out of adjustment or the clutch brake is worn and needs to be replaced.

### **Clutch Adjustments**

Clutches have an internal adjustment and external linkage adjustment. See **Group 25** of the *L-Line and A-Line Workshop Manual* for clutch adjustment procedures and specifications.

## CAUTION

**Operating the vehicle with the clutch improperly adjusted could result in clutch or clutch brake failure.**

### **Lubrication**

On vehicles equipped with a greaseable release bearing, the release bearing and linkage should be lubricated at frequent intervals. See **Group 25** of the *L-Line and A-Line Maintenance Manual* for intervals and procedures.

## CAUTION

**Failure to lubricate the release bearing and linkage as recommended could result in release bearing and clutch damage.**

# 8

## Transmissions

---

Freightliner SmartShift Transmission Shift Control, Optional .....	8.1
Eaton Fuller AutoShift Automated Models .....	8.1
Eaton UltraShift™ DM .....	8.4
Fuller Straight-Shift Models .....	8.10
Fuller Range-Shift Models .....	8.11
Fuller Splitter and Range-Shift Models .....	8.13
Fuller Deep-Reduction and Range-Shift Models .....	8.15
Allison Automatic Models .....	8.18

# Transmissions

## Freightliner SmartShift Transmission Shift Control, Optional

### General Information

The SmartShift™ transmission control is an electronic transmission control device. It is installed with the following transmissions:

- Eaton® Fuller® AutoShift™
- Eaton Fuller UltraShift™ DM
- Meritor™ SureShift

It replaces the typical floor-mounted shift lever or dash-mounted push button control.

SmartShift accepts driver requests for transmission functions and transmits them through hard wiring to the transmission control unit (TCU). SmartShift is a true shift-by-wire system.

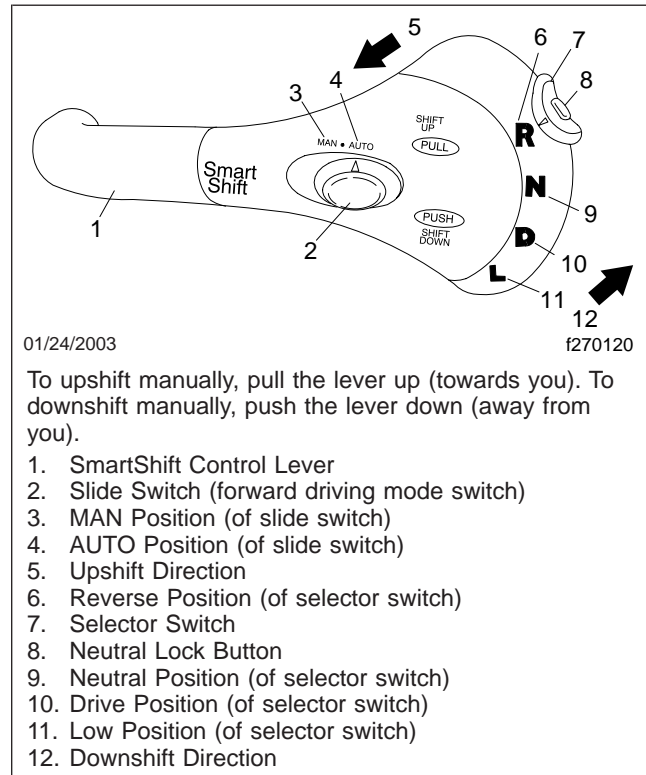
SmartShift offers two main advantages over conventional transmission control devices. Without a floor-mounted shift control, usable cab space is increased. Access to the sleeper is improved by removing the shift lever from the floor.

The SmartShift control mounts to the right-hand side of the steering column and is operated by the fingers of the driver's right hand, allowing both hands to remain on the steering wheel.

A two-position slide switch is mounted on the body of the control lever just before the paddle widens out. The slide switch allows the driver to choose automatic (AUTO) mode or manual (MAN) mode. The SureShift lever has no slide switch.

In AUTO mode, gears shift automatically, without driver interaction. Manual gear shifts (all SureShift shifts; AutoShift or UltraShift when in MAN mode) are accomplished by a momentary pull or push on the control in the plane perpendicular to the steering wheel. Pull upward (toward you) on the control to upshift and push downward (away from you) to downshift. The control is spring-loaded and returns to mid-position when released after an upshift or downshift.

For the Eaton Fuller automated transmissions, a four-position (R, N, D, L) selector switch (Fig. 8.1) is located at the end of the lever. For the Meritor SureShift transmission, a three-position (R, N, F) selector switch (Fig. 8.2) is located at the end of the lever.



**Fig. 8.1, Four-Position SmartShift Control (with Eaton Fuller transmissions)**

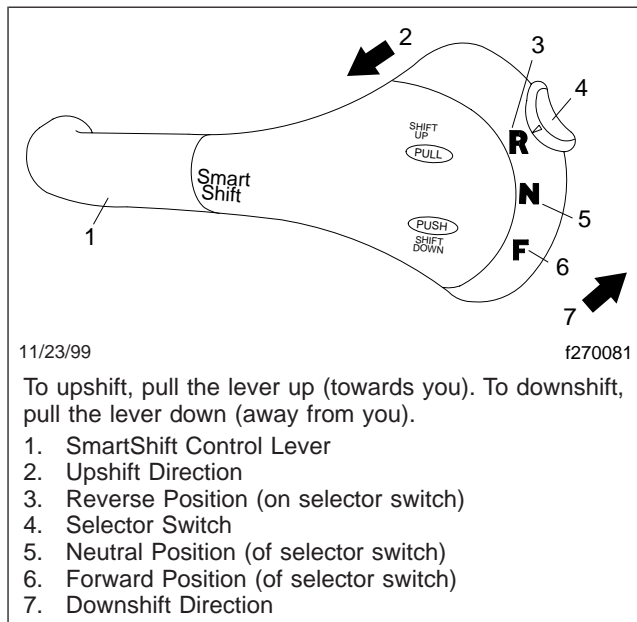
Embedded in the selector switch is a small neutral lock button to prevent accidental shifts into gear from neutral. Any time you shift through N, press down on the neutral lock button to move the switch from neutral (N) to another gear, such as drive (D), low (L), or reverse (R). When shifting to N, it is not necessary to press the neutral lock button.

## Eaton Fuller AutoShift Automated Models

### General Information, AutoShift

The AutoShift AS2 is a partially automated Eaton Fuller transmission. The driver must use the clutch and put the transmission in neutral to start and stop the vehicle.

Eaton Fuller 10-speed AutoShift transmissions have 10 forward speeds and two reverse speeds. The transmission consists of a 5-speed front section and a 2-speed rear section.



**Fig. 8.2, SmartShift Control (with Meritor SureShift transmission)**

Eaton Fuller 18-speed AutoShift transmissions have 18 forward speeds and four reverse speeds. These transmissions consist of a 5-speed front section and a 4-speed auxiliary section.

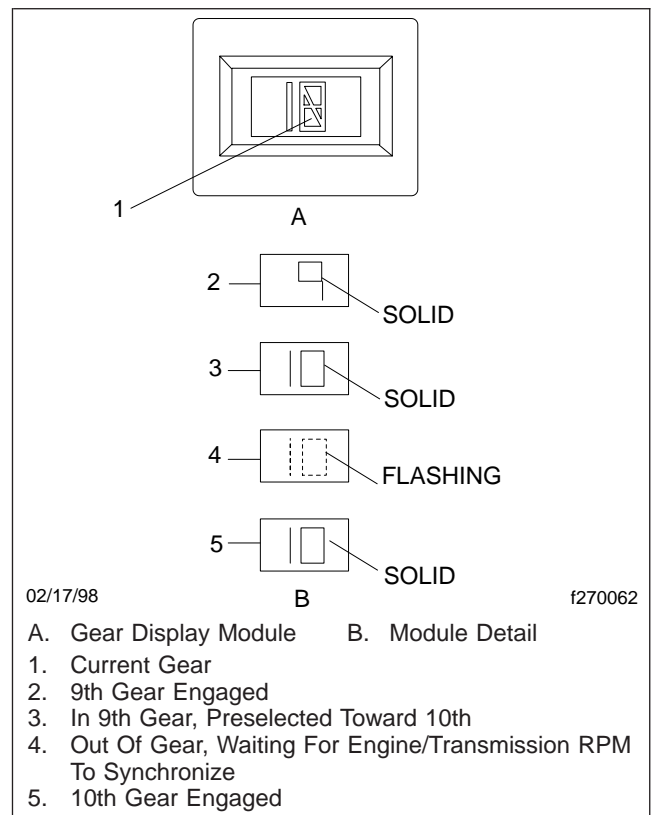
The driver does not need to break torque or increase or decrease engine speed to synchronize the shift. The transmission signals the engine controller when to break torque and the engine controller automatically increases or decreases engine speed. When engine speed is correct, the transmission engages the next gear and signals the engine controller to resume operation.

The AutoShift system consists of the following components:

- The SmartShift control paddle on the steering column.
- The gear display module (**Fig. 8.3**) mounted on the dashboard indicates the current gear position or transmission status. The display also flashes the next gear to be engaged while the transmission is in neutral during a gear change.
- The shifter mechanism performs shifts at the front portion of the transmission. It preselects

the shift to neutral and completes the gear change after driver input.

- The Electronic Control Unit (ECU) includes two controllers: a transmission ECU and a system ECU. The transmission ECU controls all transmission shift functions and the system ECU manages all vehicle interfaces for transmission shift functions.
- An electronic range valve, controlled by the transmission ECU, is used to perform range shifts.



**Fig. 8.3, Gear Display Module**

## Operation, AutoShift with SmartShift Start-Up

1. With the parking brake applied, press the clutch all the way down to the floor.
2. Start the engine.
3. Check to make sure the transmission is in neutral.



# Transmissions

---

4. With the transmission in neutral, release the clutch.

**NOTE:** This allows the speed sensor on the input shaft to get a reading.

5. Press down on the clutch again and release the parking brake.
6. Select the desired starting gear.
7. Release the clutch.

**IMPORTANT:** If you have to leave the cab with the engine running:

- Place the transmission in neutral.
- Set the parking brakes.
- Chock the tires.

## Automatic and Manual Modes

A two-position slide switch (forward driving mode switch) is located near the end of the control. The switch positions are labelled MAN (manual shift mode) and AUTO (automatic drive mode).

**NOTE:** In automatic drive mode, upshifts and downshifts require no driver interaction. Move the selector switch to the drive (D) position, disengage the clutch to engage the gear selected, engage the clutch and drive the vehicle. In manual shift mode, upshifts and downshifts require either a pull upward or push downward on the control.

## Driver Message Center

Gear information is presented to the driver via a light-emitting diode (LED) display on the dash. In automatic drive mode, the number of the forward gear currently engaged appears continually on the message display screen when in drive (D). In manual shift mode, the current gear is displayed until a new gear is requested. When neutral (N) is engaged, "N" will appear on the message display screen. When reverse (R) is engaged, either "RL" or "RH" will appear on the message display screen.

**IMPORTANT:** The information shown on the message display screen indicates the state of the transmission only, not the state of the SmartShift control.

## Neutral Position

Select neutral by sliding the selector switch to the "N" position.

**NOTE:** Neutral is always available during operation. When in neutral, upshift and downshift requests are ignored. If the mode selector switch is moved from neutral (N) to drive (D) while the vehicle is moving, the transmission will shift into a gear causing the engine to go to a high torque level, under the engine's rated torque.

## Selecting a Starting Gear

1. In automatic mode, select drive (D) by sliding the selector switch downward to the next position below the neutral position.
2. Disengage the clutch to engage the gear selected. Engage the clutch and drive the vehicle.

## Changing the Default Starting Gear

To select a starting gear other than the default starting gear, follow the instructions below.

1. Make sure the vehicle is stopped and in drive.
2. In either automatic or manual mode, pull upward on the control (to increase), or push downward (to decrease). Each pull upward on the control increases the starting gear by one gear, but no higher than fourth gear.
3. The number of the gear selected will flash on the message display screen until the driver engages the clutch. This gear will be stored in memory as the default starting gear until either a different starting gear is selected by the driver or the engine is shut down.

**NOTE:** The transmission may also be programmed so that it is not possible to select a starting gear other than the preprogrammed default starting gear.

## Reverse

1. To engage reverse (R), slide the selector switch upward to the next position above the neutral position and disengage the clutch.

**NOTE:** AutoShift 10- and 18-speed transmissions have a dual-range reverse. Reverse low (RL) is the default reverse gear.

2. Select reverse high (RH) by pulling upward on the control.

NOTE: Reverse may be engaged below a programmable forward speed in order to rock the vehicle. If reverse is selected above the programmed forward speed, an audible warning will sound and a message indicating that the gear is not available will appear on the message display screen.

## Low Gear Operation

Use low (L) when descending steep hills and using compression braking. Engine speed will be increased by 200 rpm and shift points will be offset by 200 rpm. The efficiency of the exhaust brake will be maximized.

## Using the Clutch

Use the clutch to start and stop the vehicle.

## Upshifting

NOTE: With the transmission in drive (D) in the automatic mode, upshifts require no driver interaction.

1. With the transmission in drive in the manual mode, request an upshift by pulling upward on the control. If the requested gear is available, the transmission will upshift.

NOTE: A single, momentary pull upward on the control selects the next higher gear when it is available. Two consecutive, momentary upward pulls will cause a skip shift when the next two higher gears are available and conditions are right.

2. To skip shift, move the control two times in less than 1/2 second. The number of the gear engaged will appear on the message display screen.

NOTE: The Eaton Fuller AutoShift 18-speed transmission is able to perform triple upshifts when the next three higher gears are available and conditions are right. To triple-shift this transmission, move the control three times in less than 1/2 second.

If a requested gear is not available, an audible warning will sound and the gear display module will indicate that the gear is not available. An unavailable requested upshift is not stored in memory. The upshift must be requested again.

## Downshifting

NOTE: With the transmission in drive (D) in the automatic mode, downshifts require no driver interaction.

1. With the transmission in drive in the manual mode, request a downshift by pushing downward on the control. If the requested gear is available, the transmission will downshift.

NOTE: A single, momentary push downward on the control selects the next lower gear when it is available. Two consecutive, momentary downward pushes will cause a skip shift, when the next two lower gears are available and conditions are right.

2. To skip shift, move the control two times in less than 1/2 second. The number of the gear engaged will appear on the message display screen.

NOTE: The Eaton Fuller AutoShift 18-speed transmission is able to perform triple downshifts when the next three lower gears are available and conditions are right. To triple shift this transmission, move the control three times in less than 1/2 second.

If a requested gear is not available, an audible warning will sound and the gear display module will indicate that the requested gear is not available. Unlike upshifting, an unavailable requested downshift is stored in memory and the shift will be made when the gear is available. The time limit for this memory is a programmable parameter.

## Eaton UltraShift™ DM

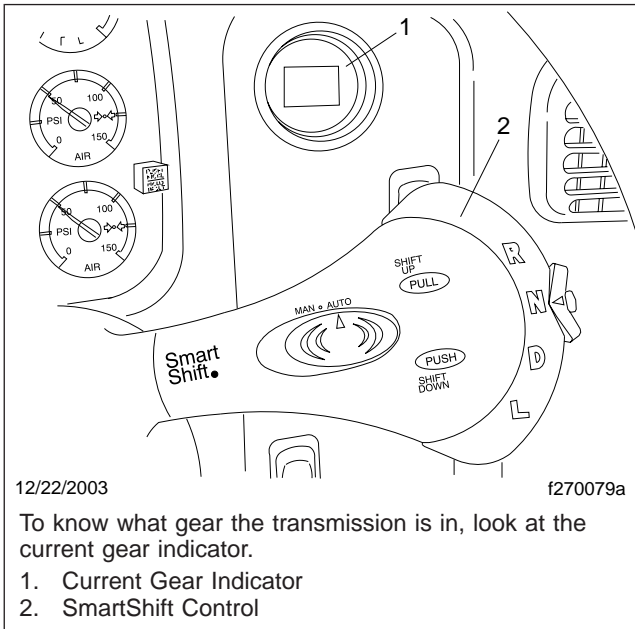
### General Information, UltraShift DM

Eaton UltraShift DM is a ten-speed heavy-duty fully automated transmission. No clutch pedal is required to operate the vehicle.

# Transmissions

UltraShift DM uses a dry clutch system which is offered only on this automated transmission system.

The UltraShift transmission uses the four-position SmartShift lever on the steering column to select gears. To know what gear the transmission is in, look at the round current gear indicator on the right-hand control panel as shown in **Fig. 8.4**. All forward shifts can be made either manually or automatically, at the driver's choice.

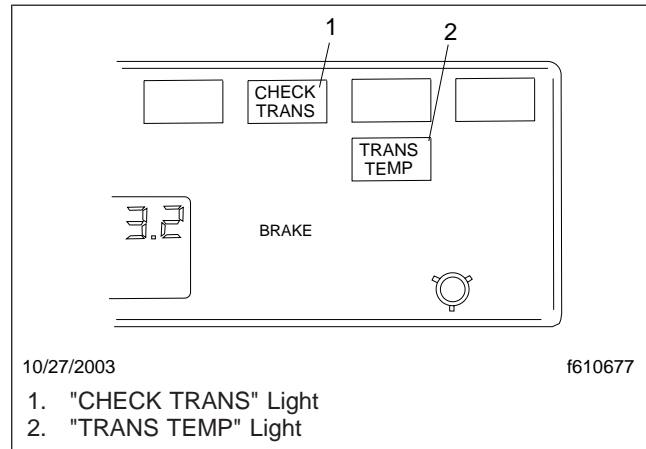


**Fig. 8.4, Shift Controls and Indicators, UltraShift Transmissions**

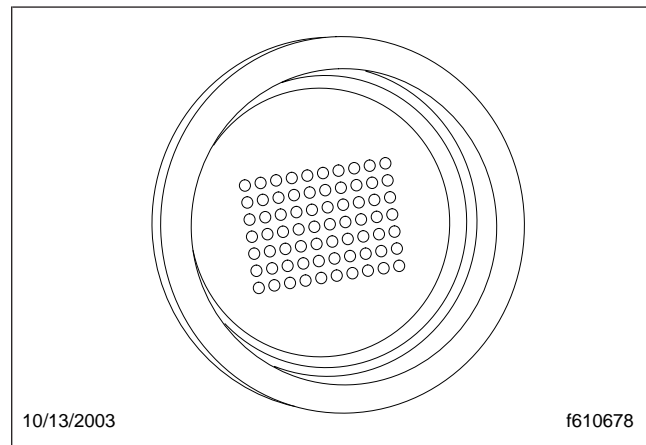
## Operation, UltraShift DM

### Power Up

1. With the parking brake set, select neutral (N) by moving the selector switch to the N position.
2. With the transmission in neutral, turn on the ignition switch. The "CHECK TRANS" and "TRANS TEMP" telltale lights come on and go out again (bulb check). See **Fig. 8.5**.
3. After the ignition is turned on, the current gear indicator shows the dot display, arranged in a square pattern. All dots in the pattern should light up, without gaps or spaces. See **Fig. 8.6**.
4. Wait for the current gear indicator to show a solid "N." When the "N" is solid, rather than flashing,



**Fig. 8.5, Telltale Lights**



**Fig. 8.6, Power Up Dot Display**

the UltraShift DM TCU is powered up. Apply the service brake and start the engine.

5. Select drive (D) by pressing in the neutral lock button and moving the selector switch downward to the position below neutral. Release the parking brake. The gear is displayed on the current gear indicator.

**NOTE:** When D is selected, the transmission controller starts up in second gear. If desired, the driver can select to start up in first. No other start gear is available.

6. On a level grade, release the service brake and press down on the throttle pedal to allow the vehicle to move forward.

## WARNING

When starting or stopping on hills and grades, use extra care to prevent the vehicle from rolling back. A rollback accident could cause death, serious personal injury, or property damage.

7. Prevent the vehicle from rolling backwards when stopped on a hill or grade, or when the vehicle is starting from a stop on a hill or grade.

7.1 To start from a full stop on a hill or grade, quickly move your foot from the brake pedal and press firmly on the throttle pedal.

On steep hills, set the parking brake and release it only when there is enough engine power to prevent rollback.

7.2 To stop on a hill or grade, press and hold the brake pedal to keep the vehicle from moving.

On steep hills, set the parking brake. When parking, chock the tires, front and/or rear. Never hold a hill with the throttle pedal. This will cause the clutch to over-heat.

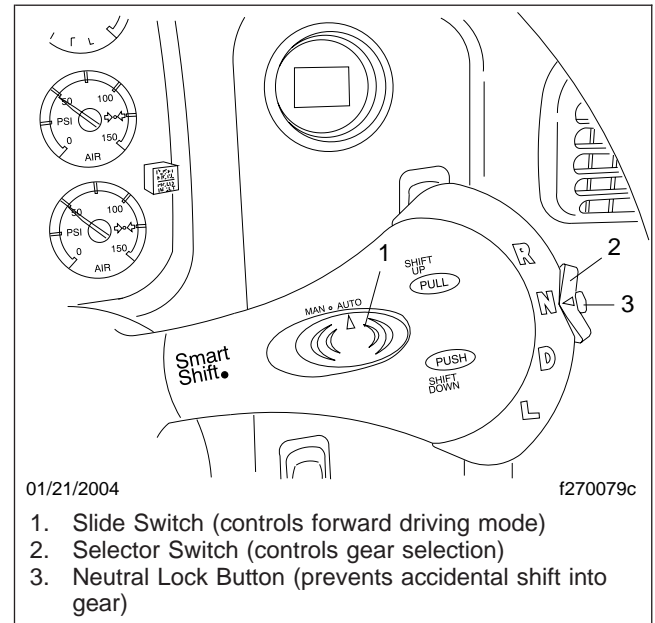
## Power Down

1. Apply the service brakes.
2. Select neutral (N) by pressing in the neutral lock button and moving the selector switch to N. When the "N" on the current gear indicator is solid, rather than flashing, the UltraShift DM TCU is ready to power down.
3. With the transmission in neutral, set the parking brake.
4. Turn off the ignition key and shut down the engine.

## Automatic and Manual Modes

The SmartShift control has a slide switch located on the body of the control lever just before the paddle widens out. See [Fig. 8.7](#). The slide switch controls the forward driving mode, automatic or manual.

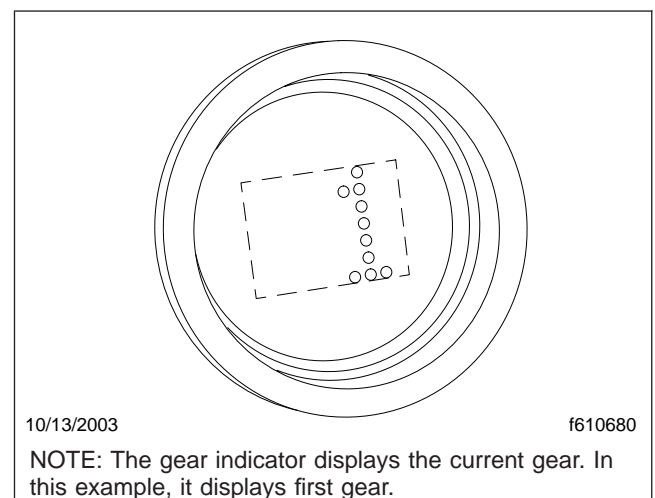
To change mode at any time, move the slide switch in the desired direction. This allows the driver to respond to a wide range of driving conditions, such as blind corners, tight curves, and steep hills.



**Fig. 8.7, Switches, UltraShift Transmissions**

**IMPORTANT:** Whatever the mode, it is always possible to shift manually by moving the lever up or down as needed. When the engine speed is within 75 revolutions per minute (rpm) of the load-based shift point for an automatic shift, the UltraShift DM TCU will advance the shift.

In either mode, the gear indicator displays the current gear. See [Fig. 8.8](#).



**Fig. 8.8, Current Gear Display**

# Transmissions

At the start of a shift, the current gear continues to display until the transmission has been pulled into neutral. At this point, as the transmission is synchronizing for the new (target) gear, the gear indicator flashes the number of the new gear.

When the shift is complete, the new gear displays solid, without flashing.

## Automatic Mode (AUTO)

In automatic drive mode (AUTO), upshifts and downshifts are made by the transmission without driver intervention. Press in the neutral lock button, move the selector switch to drive (D), and press down on the throttle pedal. The transmission will shift automatically.

If driving conditions require, it is still possible to request a manual shift. The transmission will make the shift if the engine speed is within 75 rpm of the load-based shift point for that gear.

If the driver presses down on the throttle pedal after a manual downshift in automatic mode, the transmission will upshift again if the UltraShift DM TCU requires it.

## Manual Mode (MAN)

In manual drive mode (MAN), upshifts and downshifts are made by the driver:

- To shift up, pull the lever up (towards you).
- To shift down, push the lever down (away from you).

The system will hold the current gear until the driver requests a shift. In downhill situations in particular, the driver must be alert to vehicle speed by downshifting and/or using the service brakes as needed.

A shift request will still be refused if the selected gear would cause engine overspeed or excessive lugging.

## Selecting Gears

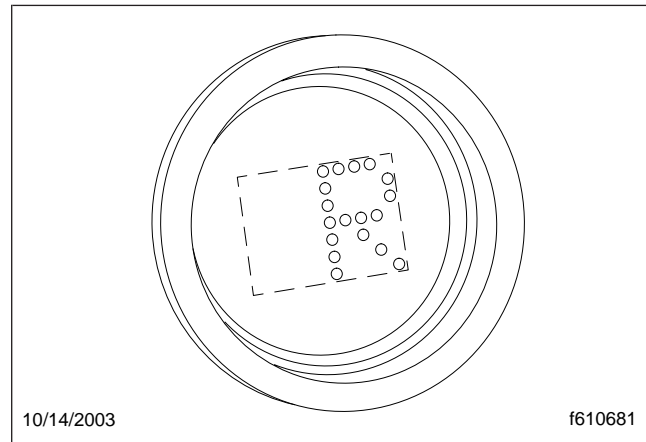
### Reverse

Reverse (R) is at the upper end of the four-position selector switch located at the end of the SmartShift control lever. To select R, press in the neutral lock button and move the selector switch upward to the position above neutral.

UltraShift DM has two reverse gears, reverse low and reverse high. To manually shift between them,

use the shift lever as described for MAN mode. There is no AUTO mode for reverse.

When reverse low is selected, the letter "R" displays on the current gear indicator. When reverse high is selected, the letter "H" displays on the current gear indicator. See [Fig. 8.9](#).



**Fig. 8.9, Reverse Gear Display**

**IMPORTANT:** Under normal conditions, do not select reverse with the vehicle moving forward.

The vehicle must be moving at less than two miles per hour (3 km/h) before selecting reverse. If reverse is selected when the vehicle is moving faster, an audible warning will sound and continue sounding at three-second intervals until the control lever is returned to the "D" position or the vehicle slows to the proper speed.

If necessary to rock the vehicle, use the selector switch to shift back and forth at low speed between reverse and drive.

### Neutral

**IMPORTANT:** Always start the engine with the transmission in neutral, the parking brake set, and the service brakes applied.

Neutral (N) is directly below R on the four-position selector switch located at the end of the SmartShift control lever. To select N, press in the neutral lock button and move the selector switch to the position below R. When neutral is selected, the letter "N" displays on the current gear indicator. See [Fig. 8.10](#).

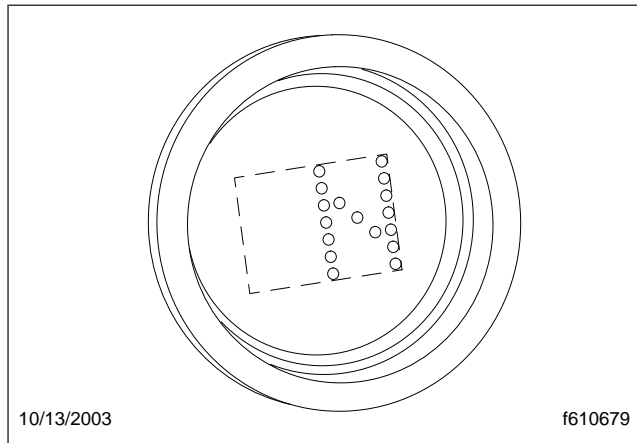


Fig. 8.10, Neutral Display

## **WARNING**

**Do not coast in neutral. Coasting in neutral can cause an accident, possibly resulting in severe personal injury or death.**

Neutral is always available during operation, whatever the vehicle speed. When in neutral, requests to upshift or downshift are ignored. If the selector switch is moved from neutral to drive while the vehicle is moving, the transmission will shift into a gear within the engine's operating speed range.

When shifting from neutral, always press on the brake pedal. If the brake pedal is not pressed, the transmission will not shift, the current gear display will flash "N," and an audible alert will sound.

**NOTE:** To reset the transmission, return the selector switch on the SmartShift lever to N and attempt the shift again, this time with the brake pedal pressed.

Before shutting down the engine, return the selector switch to N. When the ignition is turned off, the transmission will reset to neutral in a few minutes regardless of the position of the shift lever.

### Drive

Drive (D) is directly below N on the four-position selector switch located at the end of the SmartShift control lever. To select D, press in the neutral lock button and move the selector switch to the position below N. When drive is selected, the number of the

currently selected forward gear (1 through 10) displays on the gear indicator. See [Fig. 8.8](#).

When in drive, requests to upshift or downshift are enabled. Either manual or automatic mode can be selected on the slide switch.

Two starting gears are available, first and second. The default starting gear is second, but first can be selected by the driver, if desired. To change the starting gear, press the brake pedal and select D with the vehicle stopped. The current gear indicator will display the starting gear. Move the shift lever up or down until the desired starting gear is displayed.

The UltraShift DM TCU adapts to the working conditions of each vehicle and its driver. After power up or a load change, it needs to learn the new conditions. While learning, it may hold a gear too long before upshifting. Start the upshift manually. It may take three or four shifts before UltraShift succeeds in learning the new load-based shift points, but after that it will handle the shifting automatically.

### Low

Low (L) is at the lower end of the four-position selector switch located at the end of the SmartShift control lever. To select L, press in the neutral lock button and move the selector switch to the position below D.

When in low, the current gear is maintained. Requests to upshift are not enabled.

**IMPORTANT:** If the engine is approaching overspeed, the UltraShift DM TCU will override the current gear setting and upshift to prevent engine damage.

To enhance engine braking, downshifts are performed at higher rpm than normal.

If L is selected from neutral while stopped, the vehicle starts up in first gear and stays there until the engine approaches overspeed.

### Upshifting

To request an upshift with the transmission in drive, pull the control lever up (towards you). If the gear is available, the transmission upshifts and the new gear displays on the gear indicator. No skip shifts are available while upshifting.

No upshifts are available in low, except to prevent engine overspeed.

# Transmissions

---

If the transmission does not upshift quickly enough after power-up or a load change, begin the shift manually. The UltraShift DM TCU will learn the new load-based shift conditions after three or four shifts.

If the gear requested is unavailable, a tone will sound. An unavailable request to upshift is not stored in memory. The upshift must be requested again.

## Downshifting

**NOTE:** The driver can manually downshift at any time, even when the slide switch is set to AUTO mode.

To request a downshift with the transmission in drive or low, push the control lever down (away from you). If the gear is available, the transmission downshifts and the new gear displays on the gear indicator. Skip shifts are available while downshifting.

For best engine braking, select low while moving. In low, downshifts are performed at higher rpm than in drive.

**IMPORTANT:** If the engine is approaching overspeed, the UltraShift DM TCU will override the current gear setting and upshift to prevent engine damage.

If the gear requested is unavailable, a tone will sound. An unavailable request to downshift is not stored in memory. The downshift must be requested again.

When coasting to a stop, the UltraShift DM TCU may not finish the downshift until the driver presses down on the throttle pedal again.

**IMPORTANT:** A downshift request can never result in a shift into neutral, even if the vehicle is in the drive position in the lowest possible gear.

Before starting down a hill, slow down. Downshift to a speed that you can control without hard pressure on the service brakes.

Before entering a curve, slow down to a safe speed. Downshift if necessary. This lets you use some power through the curve to help the vehicle be more stable on the turn. It also allows you to regain speed faster as you come out of the curve.

## Ultrashift Diagnostics

### Clutch Protection Fault

Excessive clutch slippage creates heat and reduces the life of the clutch. These are some conditions which lead to clutch abuse:

- Using the throttle to hold the vehicle on a grade
- Starting the vehicle in too high a gear
- Overloading the vehicle
- Using high idle with the vehicle in gear

The UltraShift DM TCU is programmed to prevent clutch abuse. When the clutch overheats, the following alerts take place:

- The "TRANS TEMP" light comes on
- The current gear indicator displays "CA"
- A warning tone sounds at one second intervals

The alerts continue until the clutch cools, the throttle is released, or the clutch is fully engaged.

### System Problem

In the event of a problem, do the following steps:

1. Note the driving conditions at the time the problem occurred.
2. Record the status of the transmission at the time of the problem (AUTO or MAN mode, gear setting R, N, D, or L, current gear, engine speed, etc.)
3. Reset the system, using the procedure below.

### Reset Procedure

Transmission operation can sometimes be restored by doing the following reset procedure:

1. Stop the vehicle when it is safe to do so. Set the parking brake.
2. Place the selector switch in neutral and turn off the ignition.
3. Check all harness connectors as described in [Chapter 11](#).
4. Wait at least two minutes with the engine shut down.
5. Restart the engine.

If the problem continues, contact an authorized Sterling or Eaton service facility.

## Locked In Gear

If the transmission becomes locked in gear, a dash (–) will appear on the current gear indicator when the vehicle is restarted during the reset procedure.

**NOTE:** If the transmission becomes locked in gear while the vehicle is moving, increased braking effort may be required to stop the vehicle.

If the current gear indicator displays a dash during power-up with the selector switch in neutral, do the following steps:

1. Make sure the parking brake is set.
2. Turn off the ignition and wait at least two minutes.
3. Apply the service brakes.
4. With the service brakes applied, release the parking brake.
5. Make sure the selector switch is in neutral and turn on the ignition key. Do not attempt to start the engine at this time.
6. If necessary to get the transmission to shift into neutral, release the pressure on the brake pedal slightly.
7. Once the UltraShift DM TCU reaches neutral, a solid "N" will appear on the current gear indicator and the vehicle will start. Make sure the service brakes are applied and the parking brake is set.

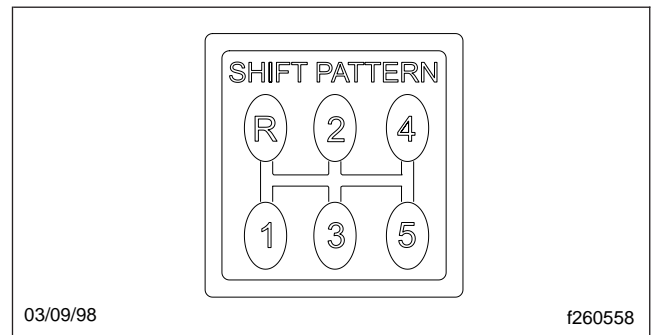
If the current gear indicator continues to display a dash, contact an authorized Sterling or Eaton service facility.

## Fuller Straight-Shift Models

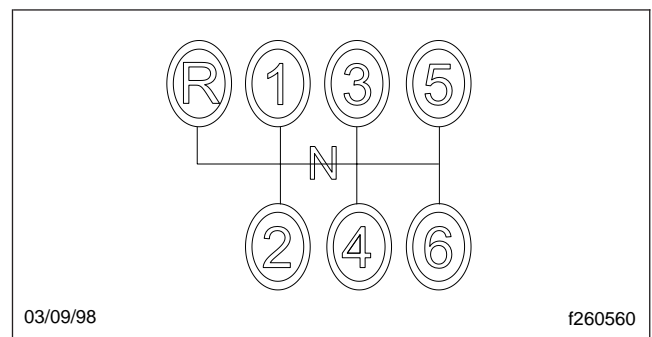
### General Information

Fuller FS–4205A/B, FS–5205B, and FS–6305A/B transmissions have five forward speeds and one reverse speed. See [Fig. 8.11](#) for the shift pattern.

Fuller FS–5306A and FS–6306A transmissions have six forward speeds and one reverse speed. See [Fig. 8.12](#) for the shift pattern.



**Fig. 8.11, Shift Pattern, FS-4205A/B, FS-205B, and FS-6305A/B**



**Fig. 8.12, Shift Pattern, FS-5306A and FS-6306A**

These transmissions are designed for use with on-highway, fuel economy engines, where a minimum of shifting is desired and less gear reduction is acceptable.

## Operation

1. Always use 1st gear when starting to move the vehicle forward.
2. Accelerate to engine governed speed. Disengage the clutch and move the shift lever to 2nd gear. Engage the clutch and accelerate to engine governed speed.
3. Continue upshifting using the same sequence described in step 2 above. Follow the pattern on the shift lever.
4. When downshifting, shift progressively down through each successive lower gear as follows:  
When the engine speed drops to the same rpm to which it fell immediately after upshifting to that same gear, disengage the clutch and move the



# Transmissions

shift lever to the next lower gear; engage the clutch smoothly.

Continue downshifting, as conditions require, using the same sequence described above.

**IMPORTANT:** Do not rest your foot on the clutch pedal while driving. This causes partial clutch disengagement, which could cause premature clutch wear.

**NOTE:** With synchronized models (FS-4205A/B, FS-5205B and FS-6305A/B) disengage the clutch completely when shifting gears. Double-clutching is unnecessary. If the vehicle is moving when shifting, depress the clutch pedal just far enough to disengage the clutch. Depressing it to the floor will engage the clutch brake, if so equipped, causing premature clutch brake wear.

## Fuller Range-Shift Models

### General Information

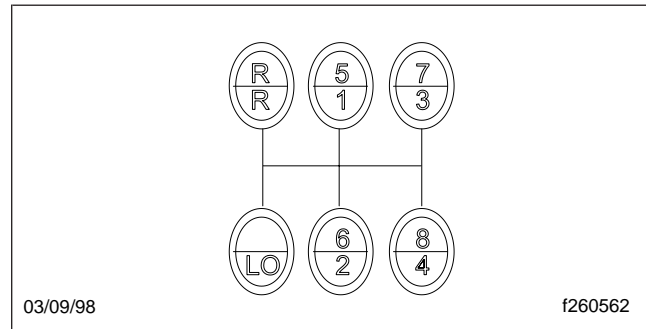
#### 9-Speed RT and RTX Models

Fuller RT-6609A, RT-8608L, RT-8709B RT-11609A, RT-11609B, RT-11709H, RT-12609A, RT-12709H, RT-13609A, RT-13709H, RT-14609A, RT-14709A, RT-14709H, RTX-11609B, RTX-11609R, RTX-11709H, RTX-12609B, RTX-12609R, RTX-12709H, RTX-13609B, RTX-13609R, RTX-13709H, RTX-14609B, RTX-14609R, RTX-14709H, RTX-16709B and RTX-16709H transmissions have a 5-speed front section, and a 2-speed rear range section. The low gear in the front sections of the A and B ratio transmissions is used only as a starting ratio. The high gear in the front section of the "R" ratio transmissions is used only as the top gear. The remaining gear positions of the above transmissions are used once in the low range and once in the high range.

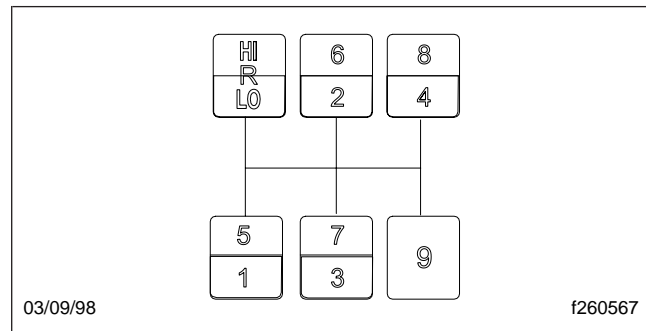
See [Figs. 8.13](#) and [8.14](#) for the shift patterns. The RTX-R ratio transmissions have the 1st/5th shift positions where LO is in the A and B ratio transmissions. The top gear in the RTX-R ratio transmissions is called 9th gear.

#### 10-Speed FR, FRO, RT, RTL, RTLO and RTX Models

Fuller FR-11210B, FR-12210B, FR-13210B, FR-14210B, FRO-11210B/C, FRO-12210B/C, FRO-



**Fig. 8.13, Fuller 9-Speed RT and RTX-B Model Transmissions Shift Pattern**



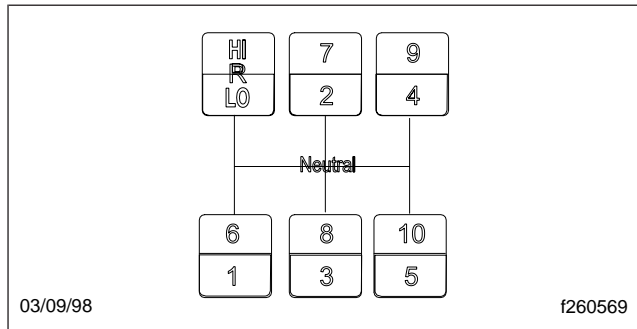
**Fig. 8.14, Fuller 9-Speed RTX-R Model Transmissions Shift Patterns**

13210B/C, FRO-14210B/C, FRO-15210B/C, FRO-16210B/C, RT-11710B, RT-12710B, RT-13710B, RT-14710B, RTL-11710B, RTL-12710B, RTL-13710B, RTL-14710B, RTLO-11610B, RTLO-12610B, RTLO-13610B, RTLO-14610B, RTLO-15610B, RTLO-16610B, RTX-11710B/C, RTX-12710B/C, RTX-13710B/C, RTX-14710B/C, RTX-15710B/C and RTX-16710B transmissions have ten selective, evenly-spaced forward ratios. Each transmission consists of a 5-speed front section, and a 2-speed rear range section. The ten forward speeds are obtained by twice using a 5-speed shift pattern: the first time in low range; the second time in high range. See [Fig. 8.15](#) for the shift patterns.

## Operation

1. When operating off-highway, or under adverse conditions, always use low gear (if so equipped) when starting to move the vehicle.

When operating on-highway, with no load, or under ideal conditions, use 1st gear when starting to move the vehicle (except when equipped



**Fig. 8.15, Fuller 10-Speed FR, FRO, RT, RTL, RTLO and RTX Model Transmissions Shift Patterns**

with a 9-speed RTO transmission, then always start in low gear).

For all conditions, use the highest gear that is still low enough to start the vehicle moving with engine idling, and without slipping the clutch excessively.

- Use the clutch brake to stop gear rotation when shifting into low (or 1st) or reverse when the vehicle is stationary. The clutch brake is actuated by depressing the clutch pedal all the way to the floor.

For normal upshifts and downshifts, only a partial disengagement of the clutch is necessary to break engine torque.

- Do not make range shifts with the vehicle moving in reverse gear.
- Never attempt to move the range preselection lever with the gear shift lever in neutral while the vehicle is moving. Preselection with the range preselection lever must be made prior to moving the shift lever out of gear into neutral.
- Do not shift from high range to low range at high vehicle speeds.
- Use double-clutching between all upshifts and downshifts.
- After your shifting ability improves, you may want to skip some of the ratios. This may be done only when operating conditions permit, depending on the load, grade, and road speed.

## Upshifting

- Position the gear shift lever in neutral. Start the engine, and bring the air system pressure up to 100 to 120 psi (689 to 827 kPa).
- Position the range preselection lever down, into low range.
- Depress the clutch pedal to the floor; shift into low or 1st gear ([Table 8.1](#)), then engage the clutch, with the engine at or near idle speed, to start the vehicle moving. Accelerate to 80 percent of engine governed speed.

TRANS. MODEL	Fuller Shift Progressions		
	LOW RANGE		HIGH RANGE
	Off-Highway	On-Highway	
8-Speed Direct (RT)			
9-Speed Direct or Overdrive (RT or RTX)			
9-Speed Direct (RTX-P)			
10-Speed Direct or Overdrive (RT or RTX)			

**Table 8.1, Fuller Shift Progressions**

- Shift progressively upward from low or 1st gear, to the top gear in low range ([Table 8.1](#)), double-clutching between shifts, and accelerating to 80 percent of engine governed speed.
- While in the top gear of the low-range shift pattern, and ready for the next upshift, flip the range preselection lever up into high range. Double-clutch through neutral, and shift into the bottom gear in high range ([Table 8.1](#)). As the shift lever passes through neutral, the transmission will automatically shift from low range to high range.
- With the transmission in high range, shift progressively upward through each of the high

# Transmissions

range gears (Table 8.1), double-clutching between shifts.

## Downshifting

1. With the transmission in high range, shift progressively downward to the bottom gear in high range, double-clutching between shifts.
2. When in the bottom gear of the high-range shift pattern, and ready for the next downshift, push the range preselection lever down into low range. Double-clutch through neutral, and shift into the top gear of the low-range shift pattern. As the shift lever passes through neutral, the transmission will automatically shift from high range to low range.
3. With the transmission in low range, downshift through the low range gears as conditions require.

Never use the clutch brake when downshifting, or as a brake to slow the vehicle.

## Fuller Splitter and Range-Shift Models

### General Information

#### 13-Speed RTLO Models

Fuller RTLO–14713A, and RTLO–16713A transmissions have thirteen forward speeds and two reverse speeds. Each transmission consists of a 5-speed front section, and a 3-speed auxiliary section. The auxiliary section contains low- and high-range ratios, plus, an overdrive splitter gear. See Fig. 8.16 for the shift pattern.

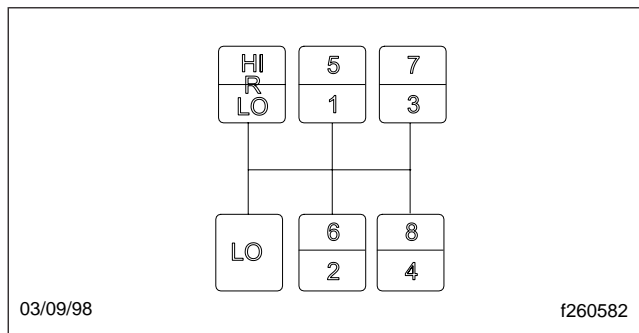


Fig. 8.16, Fuller 13-Speed RTLO Transmissions Shift Pattern

All of the thirteen speeds are controlled with one shift lever. Built into the shift knob of the lever, are a range preselection lever and a splitter control button (on the side of the shift knob), that control range selection and gear splits, respectively.

Low gear in the front section is used only as a starting ratio. The remaining four forward positions are used once in the low range and once in the high range.

#### 18-Speed RTLO Models

Fuller RTLO–18718B transmissions have eighteen forward speeds and four reverse, consisting of a 5-speed front section and a 3-speed auxiliary section. The auxiliary section contains low and high range ratios, plus an overdrive splitter gear. See Fig. 8.17 for the shift pattern.

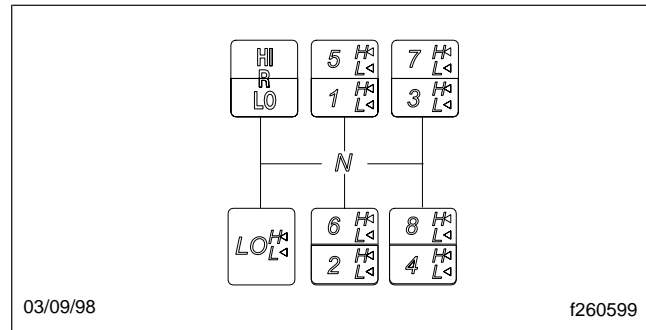


Fig. 8.17, Fuller 18-Speed RTLO Model Transmissions Shift Pattern

One ratio in the front section (low) is used as a starting ratio; it is never used when the transmission is in high range.

The other four ratios in the front section are used once in low range and once again in high range; however, each of the five ratios (low–1–2–3–4) in low range and each of the four ratios (5–6–7–8) in high range can be split with the overdrive splitter gear.

All of the eighteen speeds are controlled with one shift lever. Built into the shift knob of the lever, are a range preselection lever and a splitter control button (on the side of the shift knob), that control range selection and gear splits, respectively.

### Operation

**IMPORTANT:** The shifter knob has an interlock feature that prevents the splitter control button

from being moved forward when the range preselection lever is down (in low range); when in high range and the splitter control button is in the forward position, the range preselection lever cannot be moved down.

1. When operating off-road, or under adverse conditions, always use low gear when starting to move the vehicle forward.

When operating on-highway, with no load, or under ideal conditions, use 1st gear when starting to move the vehicle forward.

For all conditions, use the highest gear that is still low enough to start the vehicle moving with the engine at or near idle speed, and without slipping the clutch excessively.

2. Use the clutch brake to stop gear rotation when shifting into low (or 1st) or reverse when the vehicle is stationary. The clutch brake is actuated by depressing the clutch pedal all the way to the floor.

For normal upshifts and downshifts, only a partial disengagement of the clutch is necessary to break engine torque.

3. Use double-clutching between all upshifts and downshifts that require movement of the shift lever. Splitting of the high range gears does not require movement of the shift lever.
4. Never move the shift lever into low gear while in high range.
5. Never move the splitter control button while in neutral.
6. Do not preselect with the splitter control button; after moving the control button, complete the shift immediately.
7. Except when downshifting from 5th direct to 4th gear, never push the range preselection lever down into low range while operating in high range—the splitter will become inoperative.
8. Do not shift from high range to low range at high vehicle speeds.
9. Do not make range shifts with the vehicle moving in reverse gear.
10. Never attempt to move the range preselection lever with the gear shift lever in neutral while the vehicle is moving. Preselection with the range

preselection lever must be made prior to moving the shift lever out of gear into neutral.

11. After your shifting ability improves, you may want to skip some of the ratios. This may be done *only* when operating conditions permit, depending on the load, grade, and road speed.

## Upshifting

1. Position the gear shift lever in neutral. Start the engine, and bring the air system pressure up to 100 to 120 psi (689 to 827 kPa).
2. Position the range preselection lever down, into low range.
3. Make sure the splitter control button is in the direct (rearward) position.
4. Depress the clutch to the floor, shift into low; then engage the clutch, with the engine at or near idle speed, to start the vehicle moving.

To shift from low direct to low overdrive, move the splitter control button into the overdrive (forward) position, then immediately release the accelerator. Press and release the clutch pedal. After releasing the clutch, accelerate again.

5. Shift upward from low overdrive to 1st direct by first moving the splitter control button into the direct (rearward) position. Move the shift lever, double-clutching, to the 1st gear position.

Continue upshifting through the shift pattern. Double-clutch during lever shifts (1st to 2nd to 3rd to 4th); single-clutch during split shifts (1st direct to 1st overdrive, etc.).

6. When in 4th overdrive (18-speed transmissions) and ready to shift up to 5th gear, use the range shift lever as follows:

While in 4th overdrive, pull the range shift preselection lever up, into high range. The transmission will automatically shift from low to high range as the shift lever passes through neutral.

Move the shift lever, double-clutching, to the 5th gear position. Just before making final clutch engagement, move the splitter control button to the direct (rearward) position; then engage the clutch and accelerate. Do not move the control button while the shift lever is in neutral.

7. Shift up through the high range gears as follows:

# Transmissions

To shift from 5th direct to 5th overdrive, move the splitter control button into the overdrive (forward) position, then immediately release the accelerator. Press and release the clutch pedal. After releasing the clutch, accelerate again.

Continue upshifting through the shift pattern. Double-clutch during lever shifts (6th to 7th to 8th); single-clutch during split shifts (6th direct to 6th overdrive, etc.).

## Downshifting

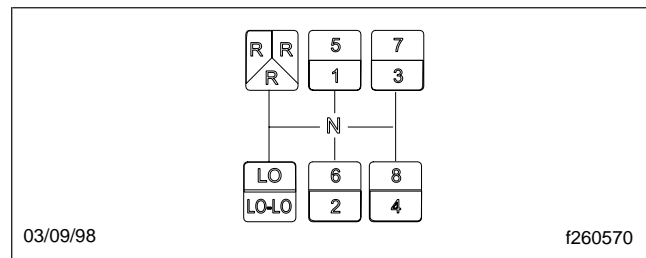
1. Downshift from 8th overdrive to 8th direct without moving the shift lever. Flip the splitter control button to the direct (rearward) position; then, immediately release the accelerator, and disengage the clutch. Engage the clutch, and accelerate the engine only after the transmission has shifted.
2. Start the downshift from 8th direct to 7th overdrive by flipping the splitter control button to the overdrive (forward) position; then, immediately double-clutch through neutral, moving the shift lever from 8th to 7th gear.
3. Shift downward through each of the high range gears, alternating the procedures in steps 1 and 2, above, until reaching 5th direct.
4. While in 5th direct and ready for the downshift to 4th overdrive, push the range preselection lever down. Then, double-clutch through neutral and move the shift lever to the 4th gear position. Move the splitter control button to the overdrive (forward) position *before* engaging the clutch. Do not move the control button while the shift lever is in neutral.
5. Continue downshifting from 4th to 1st as follows:  
Continue downshifting from 4th overdrive to 4th direct, then 4th direct to 3rd overdrive, 3rd overdrive to 3rd direct, etc. Single clutch when split shifting (direct to overdrive, overdrive to direct). Double-clutch when making lever shifts (4th to 3rd, 3rd to 2nd, etc.).

## Fuller Deep-Reduction and Range-Shift Models

### General Information

#### 10-Speed RTO Models

Fuller RTO–8908LL, RTO–11908LL, RTO–14908LL, and RTO–16908LL transmissions have a 5-speed front section, and a 2-speed rear-range section, with a deep reduction gear. The low-low, deep reduction gear is used only when operating under adverse conditions. Low gear in the front section is used only for rough, off-highway conditions, as a starting ratio. The remaining four forward positions are used once in the low range and once in the high range. See [Fig. 8.18](#) for the shift pattern.



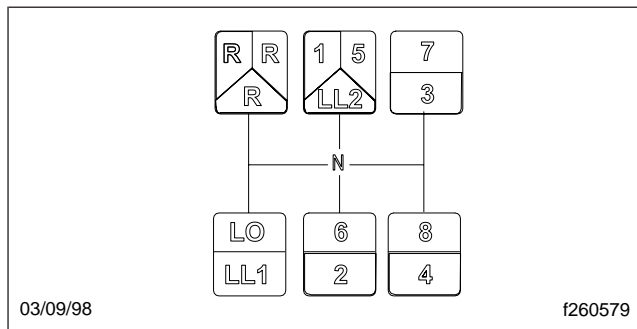
**Fig. 8.18, Fuller 10-Speed RTO Model Transmissions Shift Patterns**

#### 11-Speed RTO Models

Fuller RTO–11909LL and RTO–14909LL transmissions have a 5-speed front section, and a 2-speed rear-range section, with a deep reduction gear. The LL1-LL2, deep reduction gear is used only when operating under adverse conditions. Low gear in the front section is used only for rough, off-highway conditions, as a starting ratio. The remaining four forward positions are used once in the low range and once in the high range. See [Fig. 8.19](#) for the shift pattern.

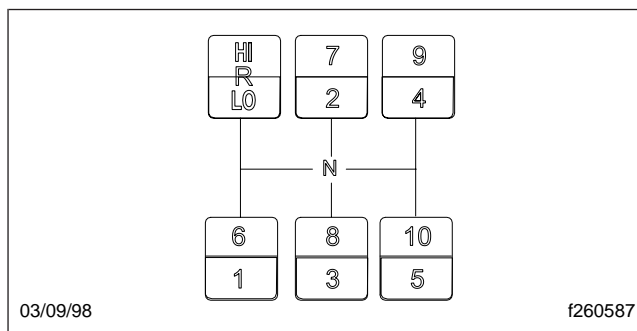
#### 15-Speed RT and RTO Models

Fuller RT–14915, RTO–14915 and RTO–19615 transmissions have a 5-speed front section, and a 2-speed rear, range section. They also have five additional deep reduction ratios. The 5-speed front section, and the low- and high-range sections provide ten evenly and progressively spaced forward speeds. The five deep reduction ratios are also evenly and progressively spaced; however, they do overlap the



**Fig. 8.19, Fuller 11-Speed RTO Model Transmissions Shift Patterns**

low-range ratios, and should be used only when operating under adverse conditions. See [Fig. 8.20](#) for the shift patterns, noting that the 4th/9th, and the 5th/10th shift positions in the RT (direct ratio) and RTX (overdrive ratio) transmissions are directly opposite in the RTO (overdrive ratio) transmissions.



**Fig. 8.20, Fuller 15-Speed RT and RTO Model Transmissions Shift Patterns**

## Operation

**IMPORTANT:** The shifter knob has an interlock feature that prevents the deep reduction button from being moved forward when the range preselection lever is up (in high range); when in low range and the deep reduction button is in the forward position, the range preselection lever cannot be moved up.

1. For all driving conditions, use the highest gear that is still low enough to start the vehicle moving with the engine idling, and without slipping the clutch excessively.

2. Use the clutch brake to stop gear rotation when shifting into low-low, low-1st (whichever is used as a starting ratio) or reverse, when the vehicle is stationary. The clutch brake is actuated by depressing the clutch pedal all the way to the floor. For normal upshifts and downshifts, only a partial disengagement of the clutch is necessary to break engine torque.
3. Use double-clutching between all upshifts and downshifts.
4. Never move the shift lever into low gear while in high range.
5. Do not preselect with the deep reduction button. When making the shift from a deep reduction ratio to a low-range ratio, move the deep reduction button from a forward position to a rearward position, then complete the shift immediately.
6. Never move the deep reduction button from a rearward position to a forward position when the transmission is in high range.
7. Do not shift from high range to low range at high vehicle speeds.
8. Do not make range shifts with the vehicle moving in reverse gear.
9. Never attempt to move the range preselection lever with the gear shift lever in neutral while the vehicle is moving. Preselection with the range preselection lever must be made prior to moving the shift lever out of gear into neutral.
10. After your shifting ability improves, you may want to skip some of the ratios. This may be done only when operating conditions permit, depending on the load, grade, and road speed.

## Upshifting

There are several patterns of upshifting, depending on the vehicle load and the road conditions. See [Table 8.2](#) for suggested shifting sequences. Deep reduction gears are best suited for heavy loads and steep inclines. Low gear (in 10-speed transmissions) is best suited for off-highway use.

# Transmissions

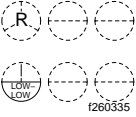
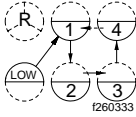
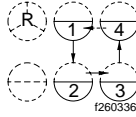
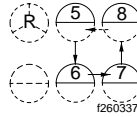
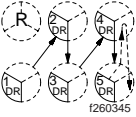
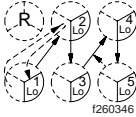
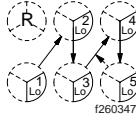
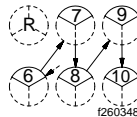
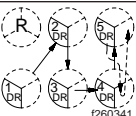
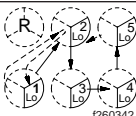
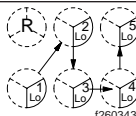
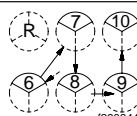
Fuller Shift Progressions				
TRANSMISSION MODEL	DEEP REDUCTION	LOW RANGE		HIGH RANGE
	Adverse Conditions Only	Off-Highway and Adverse Conditions	On-Highway and Ideal Conditions	All Conditions
10-Speed RTO	 f260335	 f260333	 f260336	 f260337
15-Speed RT	 f260345	 f260346	 f260347	 f260348
15-Speed RTO	 f260341	 f260342	 f260343	 f260344

Table 8.2, Fuller Shift Progressions

The following instructions are recommended for starting a loaded vehicle moving, under adverse conditions.

1. Position the gear shift lever in neutral. Start the engine, and bring the vehicle air system pressure up to 100 to 120 psi (689 to 827 kPa).
2. Position the range preselection lever down, into low range.
3. Move the deep reduction button to the forward position, to engage the deep reduction gears.
4. Depress the clutch pedal to the floor; shift into low-low gear (10-speed transmissions) or 1st gear of deep reduction (15-speed transmissions); then engage the clutch, with the engine at or near idle speed, to start the vehicle moving. Accelerate to 80 percent of engine governed speed.
5. For 10-speed transmissions:

When ready for the next upshift, move the deep reduction button rearward, then break torque by momentarily releasing the accelerator or depressing the clutch pedal. Do not move the shift lever.

For 15-speed transmissions:

Shift upward from 1st gear of deep reduction to 5th gear of deep reduction, double-clutching between shifts and accelerating to 80 percent of engine governed speed. See [Table 8.2](#).

When ready for the next upshift, move the deep reduction button from the forward position to the rearward position, then double-clutch through neutral, and move the shift lever to the 4th gear position in the low range.

6. Shift upward from low gear (10-speed transmissions) or 4th gear (15-speed transmissions), to the top gear in low range ([Table 8.2](#)), double-clutching between shifts, and accelerating to 80 percent of engine governed speed.
7. While in the top gear of the low-range shift pattern, and ready for the next upshift, flip the range preselection lever up into high range. Double-clutch through neutral, and shift into the bottom gear in high range ([Table 8.2](#)). As the shift lever passes through neutral, the transmission will automatically shift from low range to high range.
8. With the transmission in high range, shift progressively upward through each of the high range gears ([Table 8.2](#)), double-clutching between shifts.

## Alternate Upshifting Procedures (15-Speed Transmissions Only)

The shift from deep reduction to low range can also be made from 2nd, 3rd, or 4th gear of deep reduction, but must be made to the next gear lower in the low range. The shift from 2nd gear of deep reduction

to 1st gear in low range (or 3rd gear of deep reduction to 2nd gear in low range, and 4th gear of deep reduction to 3rd gear in low range), is an upshift, and the same procedure should be followed as that shown for shifting from 5th gear of deep reduction to 4th gear in low range. See step 5, under "Upshifting."

## Downshifting

1. With the transmission in high range, shift progressively downward to the bottom gear in high range, double-clutching between shifts.
2. When in the bottom gear of the high-range shift pattern, and ready for the next downshift, push the range preselection lever down into low range. Double-clutch through neutral, and shift into the top gear of the low-range shift pattern. As the shift lever passes through neutral, the transmission will automatically shift from high range to low range.
3. With the transmission in low range, downshift through the low range gears, as conditions require.

Never use the clutch brake when downshifting, or as a brake to slow the vehicle.

## Allison Automatic Models

### General Information

#### Allison AT-500 Series

These transmissions provide four forward speeds and one reverse range. See [Fig. 8.21](#).

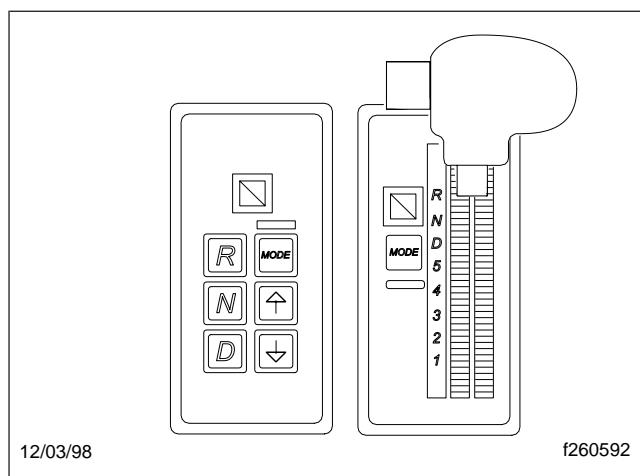


Fig. 8.21, Allison Shift Selector

### R (Reverse)

Use this position to back the vehicle. Completely stop the vehicle before shifting from R (reverse) to any forward gear. The reverse warning signal will sound when the selector is in R (reverse). Reverse has only one gear and provides the greatest gear reduction.

### N (Neutral)

Place the selector in N (neutral) before starting the engine. Shift to N (neutral) and set the parking brake any time the vehicle is parked with the engine running. The engine should be at idle speed when any shift from N (neutral) to a drive range is made.

### D (Drive-Normal Driving Position)

The transmission starts in first gear and automatically shifts through second, third and fourth depending on load and speed demands. This range is used for highway driving under normal conditions.

### 3 and 2 (Third and Second)

Road, load or traffic conditions require a lower gear. These ranges provide greater engine braking than D (drive). When conditions are improved that no longer require these lower gears, shift back to D (drive).

### 1 (First)

The transmission has to be manually shifted into 1 (first) and will not shift into a higher gear. This range is used for extra heavy loads or where maximum reduction is required.

### Allison MT-600 and HT-700 Series

These transmissions have either four or five forward speeds and one reverse range.

### R (Reverse)

Use this position to back the vehicle. Completely stop the vehicle before shifting from R (reverse) to any forward gear. The reverse warning signal will sound when the selector is in R (reverse). Reverse has only one gear and provides the greatest traction.

### N (Neutral)

Place the selector in N (neutral) before starting the engine. Shift to N (neutral) and set the parking brake



# Transmissions

---

any time the vehicle is parked with the engine running. The engine should be at idle speed when any shift from N (neutral) to a drive range is made.

## D (Drive-Normal Driving Position)

If your vehicle is equipped with the MT-643 or HT-740, your vehicle will start in 1st gear. If your vehicle is equipped with the MT-653 or HT-750, your vehicle will start in 2nd gear. The MT-643 and HT-740 transmissions startup in first gear and automatically shift through second, third and fourth depending on load and speed demands. The MT-653 and HT-750 transmissions start in second gear and automatically shift through third, fourth and fifth depending on load and speed demands. This range is used for highway driving under normal conditions.

## 4 (Fourth)

The transmission will start in second gear and automatically shifts into third and fourth depending on load and speed demands. This range is used for suburban driving where moderate reduction is required.

## 2 (Second)

The transmission operates only in second gear. This range is used for stop and go traffic or city delivery.

## 1 (First)

The transmission has to be manually shifted into 1 (first) and will not shift into a higher gear. This range is used for extra heavy loads or where maximum reduction is required.

## Allison MD and HD Series

These transmissions are electronically controlled and are available with a push button shifter or a lever shifter. MD and HD transmissions are available in five or six speed driving ranges.

If your vehicle is equipped with a push button shifter, your control has a R (reverse), N (neutral) and D (drive) selections as well as a MODE button, up arrow (for upshifts) and a down arrow (downshift) and a digital display. When a range button is pressed, a tone will sound, the SELECT indicator displays a chosen operation (if the Electronic Control Unit determines the shift is acceptable) and the transmission will shift to the starting range. In D (drive), selection of a specific gear can be accomplished by pressing the up or down arrow button. If

the CHECK TRANS light (located on the instrument panel) is illuminated, the shifter control pad will be disabled and no tones will be heard.

If your vehicle is equipped with a gearshift lever, this selector is an electromechanical control and has up to six forward speeds and one reverse range.

The MODE button may be used to activate a second shift schedule (this is typically programmed for **Economy** which will enable the transmission to shift at a lower rpm to conserve fuel).

These transmissions incorporate a hold feature to prohibit upshifting above the gear selected during normal driving. During downhill operation, the transmission may upshift from the selected gear if the Electronic Control Unit (ECU) detects the possibility of engine damage from exceeding the governed engine speed.

## **WARNING**

**These transmissions have no P (park) position. Before leaving the driver's seat, always shift into N (neutral) and set the parking brake. Shut the engine off and remove your ignition key. Always use wheel chocks for hilly or off-road parking. Unexpected and possibly sudden vehicle movement may occur if these precautions are not taken and personal injury or property damage could occur.**

Use R (reverse) to back the vehicle. Completely stop the vehicle before shifting from R (reverse) to any forward gear. The reverse warning signal will sound when the selector is in R (reverse). Reverse has only one gear and provides the greatest traction. The Select and Monitor indicators will display R when reverse is attained.

Use N (neutral) for starting the engine. If the engine starts in any gear other than N (neutral), the start circuit should be serviced immediately. Shift to N (neutral) and set the parking brake any time the vehicle is parked with the engine running. The engine should be at idle speed when any shift from N (neutral) to a drive range is made. The Select and Monitor indicators will display N.

## CAUTION

**Do not allow the vehicle to coast in neutral. This can result in severe transmission damage. Also, no engine braking is available.**

In D (drive) the vehicle will attain first gear, and as the speed increases, the transmission will automatically upshift through each gear. As the vehicle slows down, the transmission will automatically downshift. The Select indicator will display the highest gear available.

**5th through 2nd gears**—Road conditions, load or traffic can make it desirable to restrict the automatic shifting to a lower gear. These positions also provide progressively greater engine braking for descending grades (the lower the gear, the greater the braking effect).

The push button selector uses up and down arrow buttons to select the desired gear. The Select indicator will display your choice and the Monitor will display the gear when it is attained.

**1st gear**—Use for pulling through mud or deep snow, when maneuvering in tight spaces or when driving up or down steep grades. 1st gear provides maximum driving power and engine braking.

In case of engine shutdown (running out of fuel), while the transmission is in gear, the transmission will remain in gear until the ignition key is turned to the OFF position. If equipped with a shift pad control, after the ignition is turned off, the transmission will automatically shift to N (neutral) and the monitor on the shift pad will display N (neutral) when the ignition key is turned to the ON position. If equipped with a gearshift lever, the transmission will return to N (neutral) (when the ignition key is turned to OFF) but the engine cannot be restarted until the gearshift lever has been moved to the N (neutral) position.

# 9

## Rear Axles

---

Meritor Drive Axles with Main Differential Lock .....	9.1
Meritor Main Differential Lock Operation .....	9.1
Meritor Tandem Drive Axles with Interaxle Differential .....	9.1
Meritor Interaxle Differential Lockout Operation .....	9.2

# Rear Axles

## Meritor Drive Axles with Main Differential Lock

The Meritor main differential lock is a driver-controlled traction device operated from the vehicle cab. A switch allows the driver to lock or unlock the differential. An indicator light comes on when the differential lock is engaged. An optional buzzer can also be used to indicate differential lock engagement.

The main differential lock provides maximum traction under slippery conditions. When the differential lock is engaged, the clutch collar completely locks the differential case, gearing, and axle shafts together, maximizing traction of both wheels and protecting against spinout. Under normal traction conditions, do not engage the differential lock. Operate the axle with differential action between both wheels.

### WARNING

**Be especially careful when driving under slippery conditions with the differential locked. Though forward traction is improved, the vehicle can still slip sideways, causing possible loss of vehicle control, personal injury, and property damage.**

## Meritor Main Differential Lock Operation

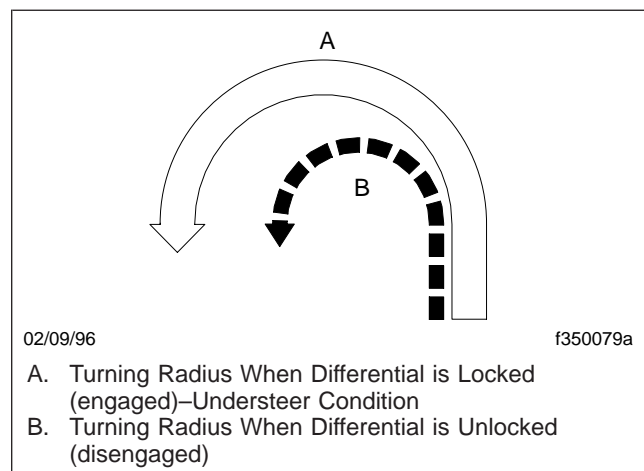
To lock the main differential and obtain maximum traction under slippery conditions, move the control switch to the lock position.

### WARNING

**Lock the main differential only when the vehicle is standing still or moving less than 25 mph (40 km/h). Never lock the main differential when the vehicle is traveling down steep grades or when the wheels are slipping. This could damage the differential or lead to loss of vehicle control, causing personal injury and property damage.**

NOTE: On some vehicles, the differential lock system is connected through the low speed range of the transmission. If this system is used, the transmission must be in the low speed range for the differential to fully lock.

If the vehicle is moving, maintain a constant vehicle speed while engaging the differential lock. Briefly let up on the accelerator to relieve torque on the gearing, allowing the differential to fully lock. The indicator light should come on and the buzzer should sound on vehicles so equipped. When the differential is fully locked, the turning radius will increase because the vehicle understeers. See **Fig. 9.1**. Drive cautiously and do not exceed 25 mph (40 km/h).



**Fig. 9.1, Turning Radius**

To unlock the main differential, move the control switch to the unlock position. Briefly let up on the accelerator to relieve torque on the gearing, allowing the differential to fully unlock.

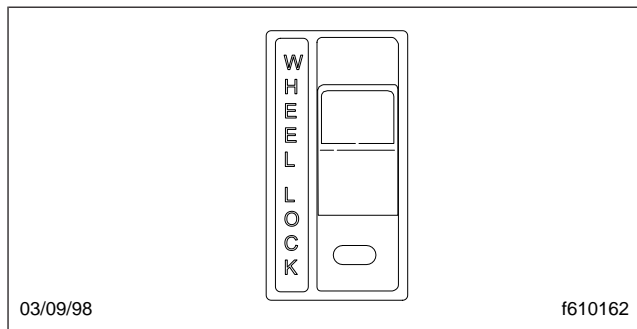
NOTE: If the differential lock system is connected through the low speed range of the transmission, shifting out of low speed range will also unlock the differential.

When the differential lock disengages, the indicator light will go off and the buzzer will stop.

## Meritor Tandem Drive Axles with Interaxle Differential

Meritor tandem drive axles with an interaxle differential have a lockout feature. Differential lockout is controlled by a switch (**Fig. 9.2**) on the control panel.

In the UNLOCK position, there is differential action between the two axles. The differential compensates for different wheel speeds and variations in tire size. Keep the interaxle differential unlocked for normal driving on roads where traction is good.



**Fig. 9.2, Interaxle Differential Control**

In the LOCK position, the interaxle differential is locked out and the driveshaft becomes a solid connection between the two axles. Power entering the forward axle is also transmitted straight through to the rear axle, so both axles turn together at the same speed. The LOCK position should be used when the vehicle encounters poor traction conditions; however, it also increases drivetrain and tire wear and should be used only when improved traction is required.

## Meritor Interaxle Differential Lockout Operation

To lock the interaxle differential and achieve maximum pulling power when approaching slippery or poor road conditions, move the lockout control valve to LOCK while maintaining vehicle speed, before encountering the poor road conditions. Let up momentarily on the accelerator to engage the differential lock. Proceed over poor road conditions with caution. Do not wait until traction is lost and the tires are spinning before locking the interaxle differential.

### CAUTION

**Do not actuate the interaxle differential control valve while the tires are slipping. Do not operate the vehicle continuously with the interaxle differential locked during extended good road conditions. To do so could result in damage to the axle gearing and excessive tire wear.**

To unlock the interaxle differential, move the lockout control valve to UNLOCK while maintaining vehicle speed, after leaving the poor road conditions. Let up momentarily on the accelerator to allow the shift, then resume driving at normal speed.

# 10

## Fifth Wheels

---

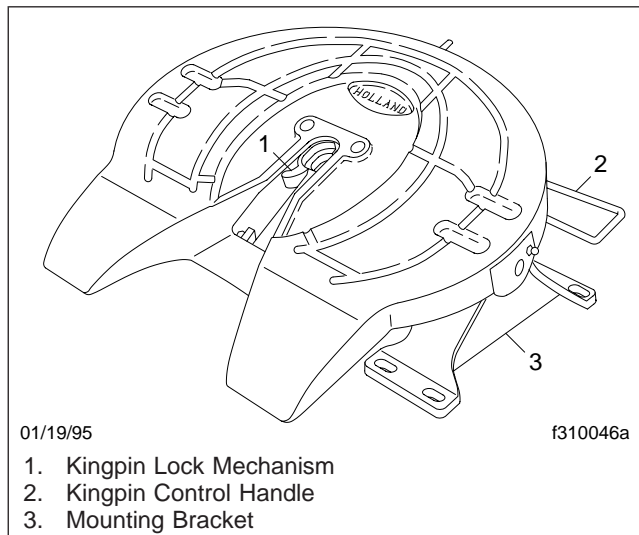
Holland Fifth Wheels .....	10.1
Fontaine Fifth Wheels .....	10.6

# Fifth Wheels

## Holland Fifth Wheels

### General Information

The 2535 sliding fifth wheel models incorporate a Model 3500 fifth wheel (**Fig. 10.1**) equipped with either an air-operated release slide, or a manual release slide. Sliding fifth wheel assemblies are mounted on a baseplate which permits forward and rear movement along notched rails. Plungers are meshed into teeth on the baseplate to lock the sliding mechanism. Disengagement of the sliding member is accomplished when the plungers are withdrawn (manually or air-operated), releasing the fifth wheel assembly so that it can be positioned for optimum weight distribution over the tractor axles.



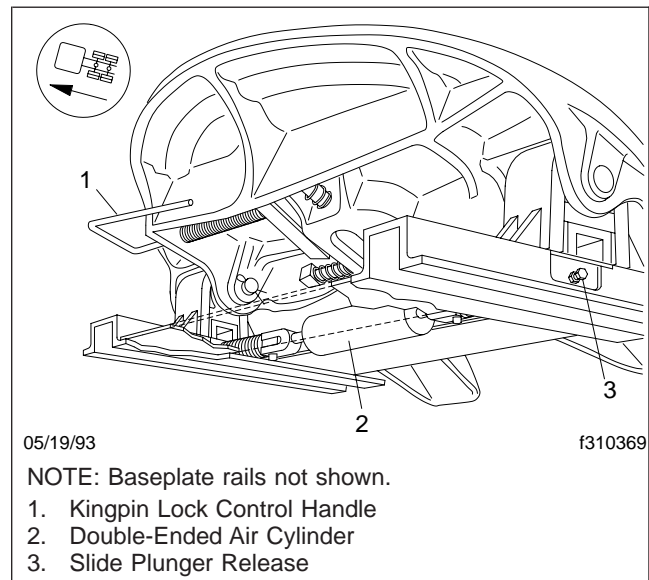
**Fig. 10.1, Holland Fifth Wheel**

The air-operated release slide assembly (**Fig. 10.2**) contains a double-ended air cylinder which locks and unlocks both sides of the sliding member at the same time. The air cylinder is activated by a two-position air-control valve in the tractor cab.

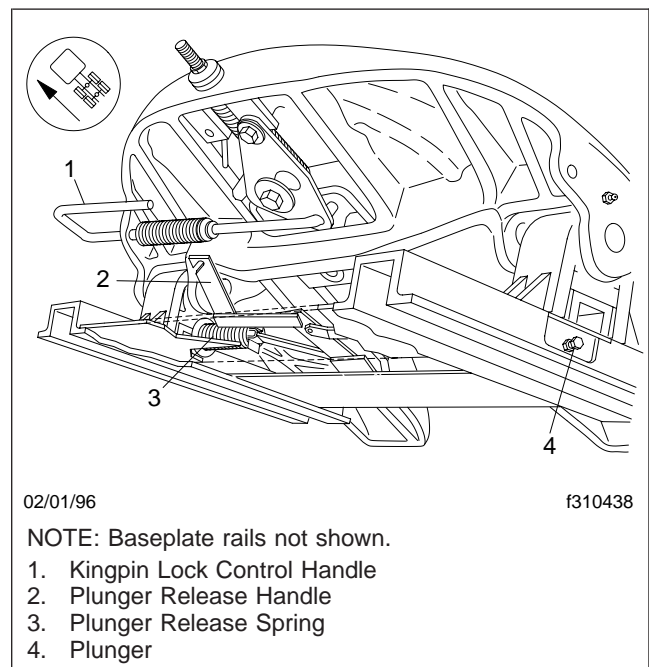
The manual release slide assembly (**Fig. 10.3**) is equipped with a single release lever. Pulling on the release lever unlocks both plungers.

### Type "B" Kingpin Lock Mechanism (**Fig. 10.4**)

The Type "B" kingpin lock mechanism utilizes two spring-loaded lock halves. The final forward motion of the kingpin into the open lock halves forces the

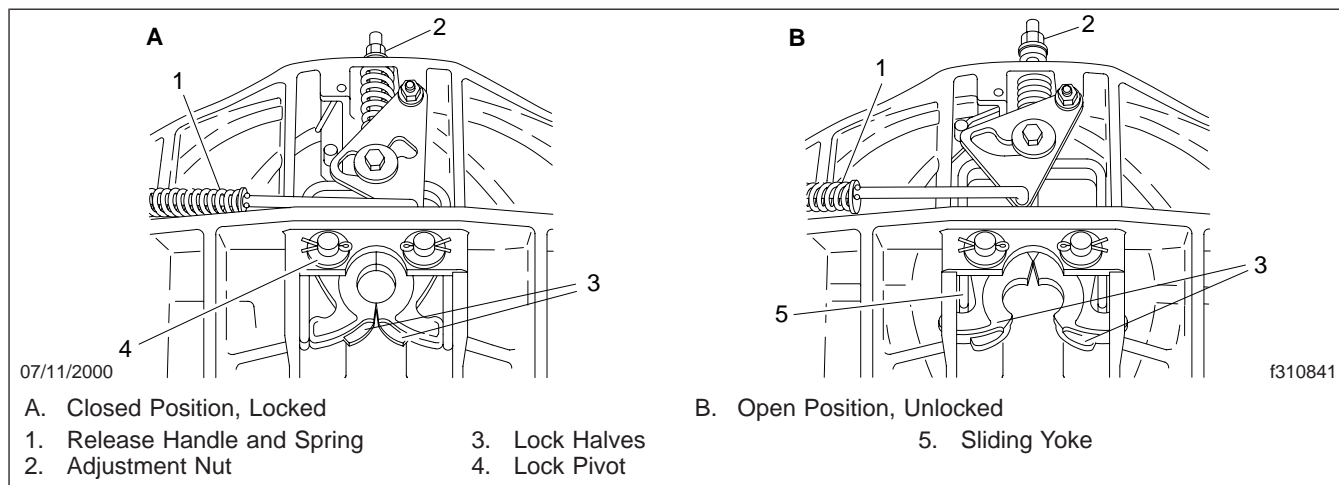


**Fig. 10.2, Air-Operated Release Slide Assembly**



**Fig. 10.3, Manual Release Slide**

locks to close in a 360 degree grip around the shoulder and neck of the kingpin, positioning sliding yokes between the lock halves and tapered rib members of the fifth wheel understructure. The kingpin can be released only by manually operating the kingpin lock



**Fig. 10.4, Type "B" Kingpin Lock Mechanism (bottom view)**

control handle. The adjustment nut will compensate for wear on the lock or kingpin.

## Lockguard (Fig. 10.4)

The Holland lockguard is a device that prevents a false lockup, and is used on all models. The Lockguard is a spring-tensioned, smooth-surfaced tongue that the kingpin passes over and depresses when entering the lock mechanism. The Lockguard will prevent the locks from engaging before the kingpin fully enters the locks. If the kingpin enters the fifth wheel incorrectly and does not depress the tongue, the locks are unable to close.

## Fifth Wheel Locking Operation

### Locking the Fifth Wheel Mechanism

#### CAUTION

**Before attempting to lock or unlock the fifth wheel lock mechanism of a sliding type fifth wheel, the slide release plungers must be in the locked position. This prevents the sliding member from moving rapidly to the far forward or rearward position, which could damage the fifth wheel or kingpin.**

1. Chock the front and rear of the trailer tires to prevent the trailer from moving.

#### WARNING

**Keep the fifth wheel plate lubricated to prevent binding between the tractor and trailer. A binding fifth wheel could cause erratic steering and loss of vehicle control, possibly resulting in serious personal injury or death.**

2. The kingpin lock mechanism must be fully open, and the fifth wheel plate must be completely lubricated with chassis grease. For lubrication instructions, refer to the frame and fifth wheel section in the vehicle maintenance manual.
3. Position the tractor so that the fifth wheel lock opening is in line (both vertically and horizontally) with the trailer kingpin. The kingpin should be in a position to enter the throat of the locking mechanism, to prevent a false lockup. See [Fig. 10.5](#). Adjust the trailer landing gear to give enough alignment height so that the fifth wheel picks up the trailer on the fifth wheel ramps.
4. With the fifth wheel lock opening aligned with the trailer kingpin, back the tractor slowly toward the trailer, making sure that the kingpin correctly enters the throat of the locking mechanism. When the trailer is picked up by the fifth wheel, stop the tractor, then continue slow backward motion until positive lockup occurs.
5. Apply the tractor parking brakes.





Standard (CMVSS) label attached to the left rear door post of the tractor. The desired load on the axle is no less than 80 percent of the maximum axle weight rating, but in no instances should the axle load exceed the maximum axle weight rating given on the FMVSS or CMVSS label.

## **WARNING**

**Do not overload any tractor axle by improperly loading the trailer. This could cause erratic steering and loss of vehicle control, possibly resulting in serious personal injury or death.**

### Unlocking the Fifth Wheel Lock Mechanism

1. Apply the tractor parking brakes.
2. Pull the trailer air supply valve to cut off the air supply to the trailer.
3. Chock the front and rear of the trailer tires to prevent the trailer from moving.

## **WARNING**

**Do not use the trailer air supply for parking trailers not equipped with spring parking brakes. This applies the trailer service brakes only. As air bleeds from the trailer brake system, brake application is lost. This could allow the unattended vehicle to roll away, possibly resulting in serious personal injury or death.**

4. Lower the trailer landing gear until the weight is removed from the fifth wheel.
5. Disconnect the tractor-to-trailer air system lines and electrical cable. Plug the air lines to prevent dirt or foreign material from entering the lines.

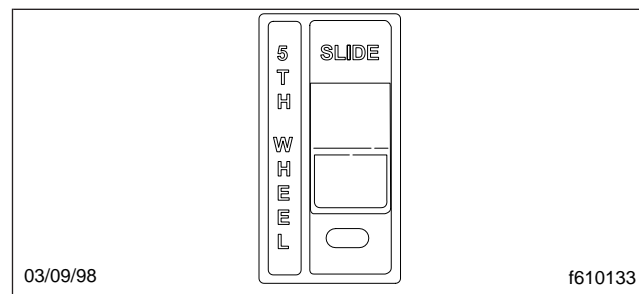
## **CAUTION**

**Before attempting to lock or unlock the fifth wheel lock mechanism of a sliding type fifth wheel, the slide release plungers must be in the locked position. This prevents the sliding member from moving rapidly to the far forward or rearward position, which could damage the fifth wheel or kingpin.**

6. Release the kingpin locking mechanism by pulling the kingpin lock control handle (**Fig. 10.1**) to the outward position.
7. Slowly drive the tractor away from the trailer.

### Fifth Wheel Slide Operation

1. Connect the trailer kingpin to the tractor fifth wheel. For instructions, refer to Holland "Fifth Wheel Locking Operation," in this chapter.
2. After positive lockup of the fifth wheel lock mechanism has been accomplished, release the sliding member using one of the following methods:
  - 2.1 For air-operated models, set the cab-operated control switch (**Fig. 10.6**) to UNLOCK.



**Fig. 10.6, Cab Control, Fifth Wheel Slide**

- 2.2 For manual release models, pull the release lever (**Fig. 10.3**) using a release hook, or other suitable tool. Make sure both slide plungers have released. See **Fig. 10.7**. If the plungers haven't released (haven't come out), lower the trailer landing gear to relieve pressure on the plungers.
3. Lower the trailer landing gear just enough to remove the weight from the tractor.
4. Pull the trailer air supply valve to cut off the air supply to the trailer.
5. Chock the front and rear of the trailer tires to prevent the trailer from moving.

## **WARNING**

**Do not use the trailer air supply for parking trailers not equipped with spring parking brakes.**

# Fifth Wheels

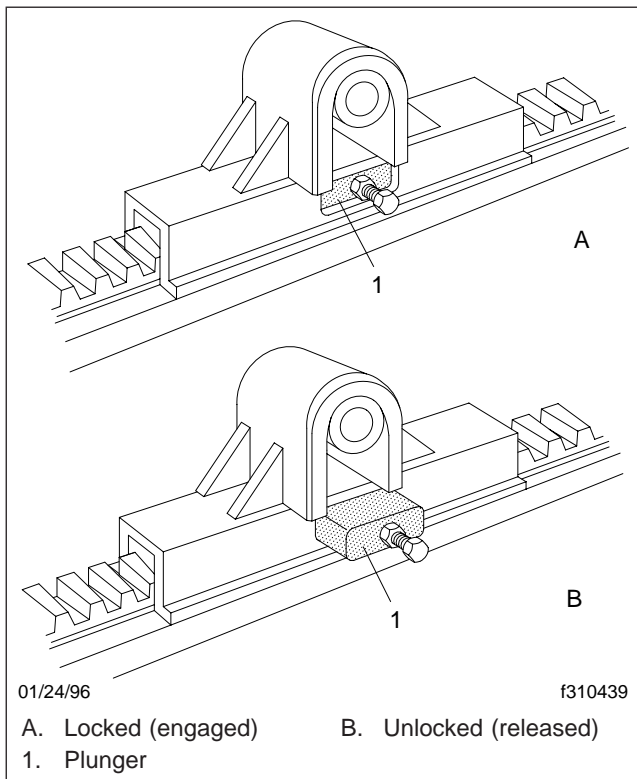


Fig. 10.7, Plunger Positions

This applies the trailer service brakes only. As air bleeds from the trailer brake system, brake application is lost. This could allow the unattended vehicle to roll away, possibly resulting in serious personal injury or death.

## CAUTION

After moving the fifth wheel to the desired position, be sure the trailer landing gear will not, at any time, come in contact with the tractor frame or other components. Make sure that the front of the trailer will not come in contact with the rear of the cab or with other components if they extend beyond the rear of the cab.

6. Slowly move the tractor forward or backward until the fifth wheel is in the desired location.
7. Apply the tractor parking brakes.

NOTE: The fifth wheel may have to be moved slightly to enable the locking plungers to enter the fully locked position.

8. Lock the sliding member into position using one of the following methods:

## WARNING

Check to be sure that the slide plungers are in the locked position. Failure to achieve complete lockup may allow disengagement of the tractor from the trailer, possibly resulting in serious personal injury or death.

- 8.1 For air-operated models, set the cab-operated control switch to LOCK. Visually check the slide plungers to make sure they are engaged in the fully locked position. See Fig. 10.7.
  - 8.2 For manual release models, trip the release lever (Fig. 10.3) using a release hook or other suitable tool. Make sure that both plungers have locked (retracted into their pockets), and are fully engaged in the rack teeth. See Fig. 10.7. It may be necessary to move the tractor slightly while keeping the trailer brakes locked.
9. The amount of load distribution on the front steering axle and rear drive axle(s) will have a direct effect on the steering control of the vehicle.

Determine the front and rear axle weights by weighing the vehicle on scales designed for this purpose.

The maximum axle weight ratings are shown on the Federal Motor Vehicle Safety Standard (FMVSS) label or Canadian Motor Vehicle Safety Standard (CMVSS) label attached to the left rear door post of the tractor. The desired load on the axle is no less than 80 percent of the maximum axle weight rating, but in no instances should the axle load exceed the maximum axle weight rating given on the FMVSS or CMVSS label.

## WARNING

Do not overload any tractor axle by improperly loading the trailer. This could cause erratic steering and loss of vehicle control, possibly resulting in serious personal injury or death.

## Fifth Wheel Lubrication

### **WARNING**

Keep the fifth wheel plate lubricated to prevent binding between the tractor and trailer. A binding fifth wheel could cause erratic steering and loss of vehicle control, possibly resulting in serious personal injury or death.

For lubrication instructions, see **Group 31** of the *L-Line and A-Line Maintenance Manual*.

## Fontaine Fifth Wheels

### General Information

The Fontaine sliding fifth wheel mount is designed to provide optimum axle loading for maximum tractor use with different lengths and types of trailers. The sliding fifth wheel mount is used with the Fontaine 5092 series fifth wheel, and the 6000/7000 No-Slack II series, and is equipped with either an air-operated release slide (AWB or HAWB models), or a manual release slide (MWS and HMWS models).

On Fontaine fifth wheels kingpin release is accomplished by activating a manual lock control handle located on either the right side or left side of the fifth wheel. Kingpin lockup occurs when the kingpin is forced into the jaws and the lock control handle moves to the locked position.

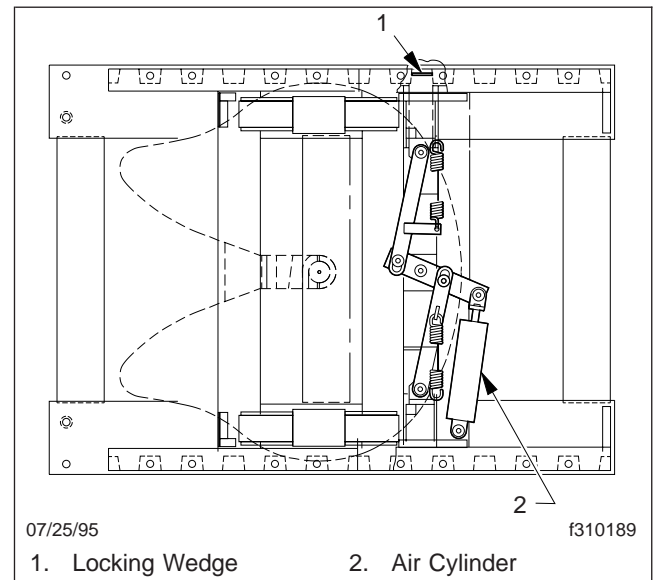
The fifth wheel top plate is mounted on a slide assembly, which is attached to slide rails that are mounted on the vehicle frame. The slide rails permit forward and rearward movement of the slide assembly, allowing for optimum weight distribution over the tractor axles.

Slots are evenly spaced along the slide rails, and retractable tapered wedges are positioned through the slots to hold the fifth wheel in the desired position. See [Fig. 10.8](#) or [Fig. 10.9](#).

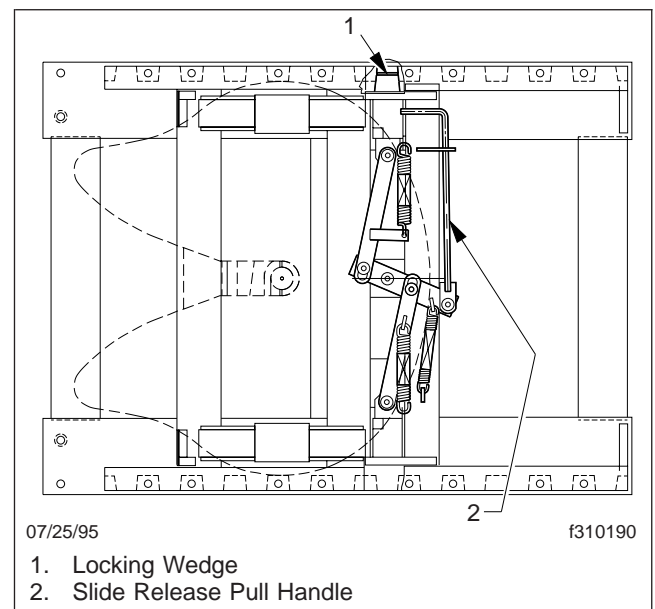
The slide portion of the sliding model may be attached to either an air-operated release slide, or a manual release slide.

The air-operated release slide contains an air cylinder that locks and unlocks the fifth wheel slide. See [Fig. 10.8](#). The air cylinder is activated by a two-position air-control valve in the tractor cab.

The manual release slide contains a slide release pull handle, located on the left side of the fifth wheel,



**Fig. 10.8, Air-Operated Sliding Fifth Wheel Mount, AWB Model**



**Fig. 10.9, Manual Release Sliding Fifth Wheel Mount, MWS Model**

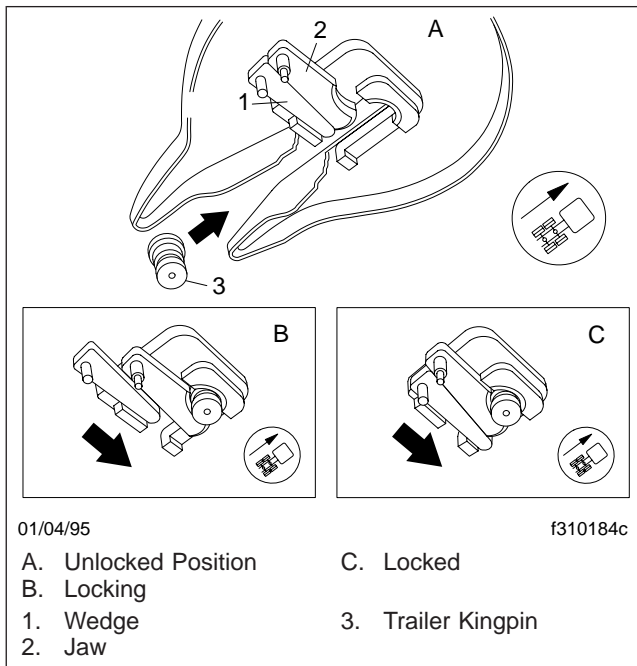
which locks or unlocks the fifth wheel slide. See [Fig. 10.9](#).

# Fifth Wheels

## Fifth Wheel Lock Mechanism for Trailer Kingpin (Fig. 10.10)

The Fontaine fifth wheel lock mechanism for the trailer kingpin consists of a spring-loaded jaw and a sliding wedge.

The jaw and wedge each have a pin permanently attached. The pin on the jaw and the pin on the wedge fit into elongated notches in the lock control handle. The notches in the handle control the limit of movement for both the jaw and wedge. The notches are arranged so that the wedge is actuated first during release of the kingpin.



**Fig. 10.10, Fontaine Kingpin Lock Mechanism**

During lockup, the jaw is moved first with the spring-loaded wedge being allowed to slip in place against the jaw. A timing bracket ensures that the wedge and jaw are moved at the proper time.

Placing the lock control handle in the unlocked position moves the wedge away from the jaw. This action unlocks the jaw so that it can be moved by the trailer kingpin. When the tractor is moved out from under the trailer, the kingpin moves the jaw until the kingpin is out of the mechanism. With the jaw in the unlocked position, the lock control handle will remain in the unlocked position until manually moved by the operator.

During coupling (Fig. 10.10), the motion of the kingpin entering the jaw will actuate the jaw and wedge. The jaw will move behind the kingpin, followed by the wedge. The purpose of the wedge is to reinforce the jaw and take up slack around the pin. Any wear on the jaw is immediately taken up by the wedge so there is no slack in the connection.

## Fifth Wheel Locking Operation Locking the Fifth Wheel Lock Mechanism

### CAUTION

Before attempting to lock or unlock the fifth wheel lock mechanism of a sliding type fifth wheel, the slide release pull handle, if so equipped, and the slide locking wedges must be in the locked position. This prevents the sliding member from moving rapidly to the far forward or rearward position, which could damage the fifth wheel member or kingpin.

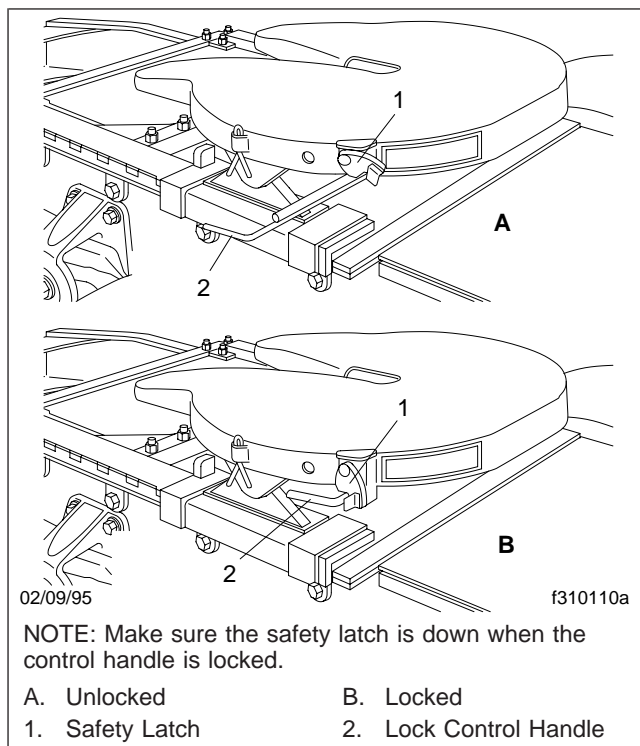
1. Chock the front and rear of the trailer tires to prevent the trailer from moving.

### WARNING

Keep the fifth wheel plate lubricated to prevent binding between the tractor and trailer. A binding fifth wheel could cause erratic steering and loss of vehicle control, possibly resulting in serious personal injury or death.

2. The kingpin lock mechanism must be fully open, the fifth wheel plate must be completely lubricated with chassis grease. For lubrication instructions, see **Group 31** of the *L-Line and A-Line Maintenance Manual*.
3. Position the tractor so that the fifth wheel lock opening is in line (both vertically and horizontally) with the trailer kingpin. The kingpin should be in a position to enter the throat of the locking mechanism (Fig. 10.10). Adjust the trailer landing gear to give enough alignment height for positive kingpin lockup.
4. With the fifth wheel lock opening aligned with the trailer kingpin, back the tractor slowly toward the trailer, making sure that the kingpin enters the throat of the locking mechanism. Continue backward motion until positive lockup occurs.

5. Apply the tractor parking brakes.
6. Make a visual and physical check for positive kingpin lockup. When lockup has occurred, the fifth wheel control handle will have moved to the locked position. Make sure that the safety latch is down over the lock control handle. See **Fig. 10.11**. This will hold the control handle in the locked position.



**Fig. 10.11, Fontaine Fifth Wheel, Locking and Unlocking**

7. Release the tractor parking brakes. Test for kingpin lockup by pulling on the trailer against the chocks.

## NOTICE

Always make sure the connect-hanger/support keeps the trailer air hoses and electrical cables positioned so that they do not rub on anything. Rubbing may wear through hoses or cables, resulting in air leaks, or exposed or broken wires, potentially affecting trailer brake or electrical systems.

8. After lockup is completed, connect the tractor-to-trailer air system lines and the electrical cable to the trailer. Take care to prevent dirt or foreign material from entering the air system lines.
9. Charge the air brake system with air. Make sure that the air connections do not leak.

## WARNING

**Eliminate slack between the trailer and the tractor. Incorrect fifth wheel adjustment could cause the trailer to disconnect, possibly resulting in serious personal injury or death.**

10. With the trailer wheels chocked and the brakes set, check for clearance between the kingpin and the fifth wheel jaws by moving the tractor forward and backward against the locked kingpin. There should be no slack between the tractor and the trailer. If slack is present, uncouple the trailer.

For adjustment instructions, refer to the applicable manufacturer's service information.

11. Retract the trailer landing gear, and secure the ratchet handle. Remove the chocks from the trailer tires.
12. The load distribution on the front steering axle and rear drive axle(s) will have a direct effect on the steering control of the vehicle.

Determine the front and rear axle weights by weighing the vehicle on scales designed for this purpose.

The maximum axle weight ratings are given on the Federal Motor Vehicle Safety Standard (FMVSS) label or Canadian Motor Vehicle Safety Standard (CMVSS) label attached to the left rear door post of the tractor. The desired load on the axle is no less than 80 percent of the maximum axle weight rating, but in no instances should the axle load exceed the maximum axle weight rating given on the FMVSS or CMVSS label.

## WARNING

**Do not overload any tractor axle by improperly loading the trailer. This could cause erratic steering and loss of vehicle control, possibly resulting in serious personal injury or death.**

# Fifth Wheels

## Unlocking the Fifth Wheel Lock Mechanism

1. Apply the tractor parking brakes.
2. Pull the trailer air supply valve to cut off the air supply to the trailer.

### WARNING

Do not use the trailer air supply for parking trailers not equipped with spring parking brakes. This applies the trailer service brakes only. As air bleeds from the trailer brake system, brake application is lost. This could allow the unattended vehicle to roll away, possibly resulting in serious personal injury or death.

3. Chock the front and rear of the trailer tires to prevent the trailer from moving.
4. Lower the trailer landing gear until the weight is removed from the fifth wheel.
5. Disconnect the tractor-to-trailer air system lines and electrical cable. Plug the air lines to prevent dirt or foreign material from entering the lines.

### CAUTION

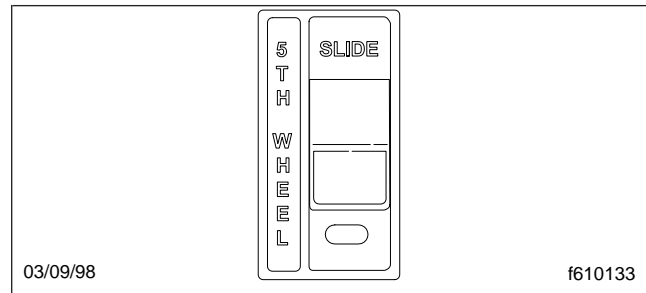
Before attempting to lock or unlock the fifth wheel lock mechanism of a sliding type fifth wheel, the slide release pull handle, if so equipped, and the slide locking wedges must be in the locked position. This prevents the sliding member from moving rapidly to the far forward or rearward position, which could damage the fifth wheel member or kingpin.

6. Release the kingpin locking mechanism by lifting the safety latch and pulling the lock control handle to the unlocked position. See [Fig. 10.11](#).
7. Slowly drive the tractor away from the trailer.

## Fifth Wheel Slide Operation

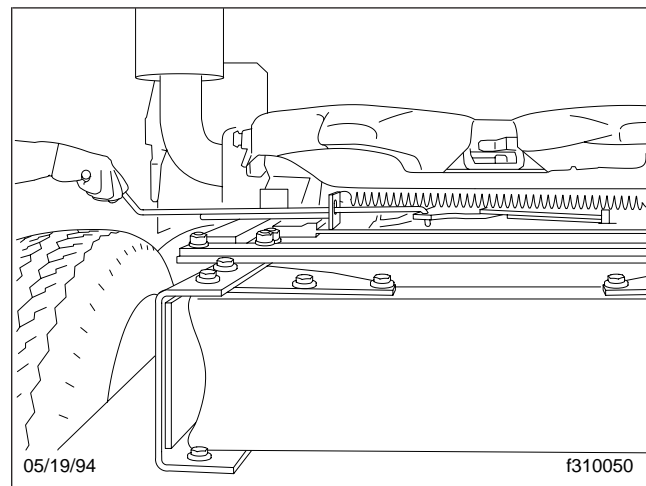
1. Connect the trailer kingpin to the tractor fifth wheel. For instructions, refer to Fontaine "Fifth Wheel Locking Operation," in this chapter.
2. After positive lockup of the fifth wheel lock mechanism has been accomplished, release the slide using one of the following methods:

- 2.1 For air-operated release models, set the cab-operated control switch ([Fig. 10.12](#)) to SLIDE.



**Fig. 10.12, Cab Control, Fifth Wheel Slide**

- 2.2 For manual release models, lift the slide release pull handle to disengage it from the guide plate. Then, pull out the handle ([Fig. 10.13](#)) until it is in the unlocked position and can be positioned against the guide plate to hold it out. The slide release pull handle will stay in the unlocked position until it is manually disengaged from the guide plate.



**Fig. 10.13, Fontaine Sliding Fifth Wheel Manual Release**

3. Lower the trailer landing gear just enough to remove the weight from the tractor.
4. Pull the trailer air supply valve to cut off the air supply to the trailer.

## WARNING

**Do not use the trailer air supply for parking trailers not equipped with spring parking brakes. This applies the trailer service brakes only. As air bleeds from the trailer brake system, brake application is lost. This could allow the unattended vehicle to roll away, possibly resulting in serious personal injury or death.**

5. Chock the front and rear of the trailer tires to prevent the trailer from moving.

## CAUTION

**After moving the fifth wheel to the desired position, be sure the trailer landing gear will not, at any time, come in contact with the tractor frame or other components. Make sure that the front of the trailer will not come in contact with the rear of the cab or with other components if they extend beyond the rear of the cab.**

6. Slowly move the tractor forward or backward until the fifth wheel is in the desired location.
7. Apply the tractor parking brakes.

**NOTE:** The fifth wheel may have to be moved slightly to enable the locking wedges to enter the fully locked position.

8. Lock the sliding member in position using one of the following methods:

## WARNING

**Check to be sure that the locking wedges have seated in the slots. Failure to achieve complete lockup may allow disengagement of the tractor from the trailer, possibly resulting in serious personal injury or death.**

- 8.1 For air-operated release models, set the cab-operated slide control switch to the lock position. Visually inspect the slide plungers to make sure that they are engaged in the fully locked position.
- 8.2 For manual release models, disengage the slide release pull handle from the guide plate. The slide release pull handle is spring-loaded in the locked position and will seek the locked position when disen-

gaged from the guide plate. The fifth wheel may have to be moved slightly to enable the locking wedges to fully enter the locked position. When the slide release pull handle returns to the fully locked position, visually and physically check the locking wedges to make sure they are fully inserted into the slots in the slide rails. Make sure the slide release pull handle is locked in position against the guide plate.

9. The amount of load distribution on the front steering axle and rear drive axle(s) will have a direct effect on the steering control of the vehicle.

Determine the front and rear axle weights by weighing the vehicle on scales designed for this purpose.

The maximum axle weight ratings are given on the Federal Motor Vehicle Safety Standard (FMVSS) label or Canadian Motor Vehicle Safety Standard (CMVSS) label attached to the left rear door post of the tractor. The desired load on the axle is no less than 80 percent of the maximum axle weight rating, but in no instances should the axle load exceed the maximum axle weight rating given on the FMVSS or CMVSS label.

## WARNING

**Adjust the fifth wheel slide correctly, and do not overload any tractor axle by incorrectly loading the trailer. Incorrect slide adjustment or improper axle loading could cause erratic steering and loss of vehicle control, possibly resulting in serious personal injury or death.**

## Fifth Wheel Lubrication

## WARNING

**Keep the fifth wheel plate lubricated to prevent binding between the tractor and trailer. A binding fifth wheel could cause erratic steering and loss of vehicle control, possibly resulting in serious personal injury or death.**

For lubrication instructions, see **Group 31** of the *L-Line and A-Line Maintenance Manual*.



# 11

## Pretrip and Post-Trip Inspections and Maintenance

---

Pretrip and Post-Trip Inspection Checklists .....	11.1
Pretrip and Post-Trip Maintenance Procedures .....	11.3

# Pretrip and Post-Trip Inspections and Maintenance

---

## Pretrip and Post-Trip Inspection Checklists

Regulations in both Canada and the United States clearly indicate that it is the driver's responsibility to perform an inspection and ensure the complete road-worthiness of a vehicle before placing it into service for the day. Commercial vehicles may be subject to inspection by authorized inspectors, and an unsafe vehicle can be put "out of service" until the driver or owner repairs it.

**IMPORTANT:** The pre- and post-trip checklists, and inspections and maintenance procedures detailed in this chapter, are **not all-inclusive**. Also refer to other component and body manufacturers' instructions for specific inspection and maintenance instructions.

Use the inspection checklists to ensure that vehicle components are in good working condition before each trip. A driver that is familiar with the vehicle, and drives it regularly, can perform the daily inspections, then add the weekly and monthly post-trip inspections as scheduled. If the driver does not operate the vehicle on a consistent basis, all three of the inspection procedures should be performed before the trip.

**NOTE:** Procedure reference numbers in the checklists reference the corresponding detailed instructions found under the pretrip and post-trip maintenance procedures.

Pre- and post-trip inspections cannot be done quickly. However, careful inspections save time by eliminating stops later to adjust items overlooked or forgotten.

If any system or component does not pass this inspection, it must be corrected before operating the vehicle. Whenever equipment requires adjustment, replacement, repair, addition of lubricants, or a change of lubricants, see the *L-Line and A-Line Workshop Manual* for procedures and specifications, and see the *L-Line and A-Line Maintenance Manual* for lubricant recommendations, specifications, and maintenance intervals.

See **Table 11.1** for a list of procedures that should be performed daily, before the first trip.

See **Table 11.2** for a list of procedures that should be performed weekly, post-trip.

See **Table 11.3** for a list of procedures that should be performed monthly, post-trip.

**IMPORTANT:** Before performing any checks, apply the parking brake and chock the tires.

# Pretrip and Post-Trip Inspections and Maintenance

Procedure Performed (check off)	Daily Pretrip Inspections/Checks	Procedure Reference
_____	Drain manually drained air reservoirs (that are not equipped with automatic drain valves)	D1
Check _____	windshield washer reservoir fluid	D2
Inspect _____	wheel seal and hub cap (for leakage)	—
Check _____	surge tank coolant level	D3
Inspect _____	radiator and charge air cooler	D4
Check _____	engine for fuel, oil, or coolant leaks	—
Inspect _____	engine and chassis wiring	D5
Inspect _____	air intake system	D6
Check _____	intake-air restriction indicator mounted on air intake	D6
Check _____	engine oil level	D7
Check _____	power steering fluid level	—
Inspect _____	fuel tank(s), fuel lines, and connections	D8
Check _____	fuel level	D9
Check _____	fuel/water separator	D10
Inspect _____	front and rear suspension components	D11
Inspect _____	headlights, mirrors, and window glass, and windshield wipers	D12
Check _____	doors (open without difficulty and close securely)	—
_____	Adjust driver's seat, then align rearview and downview mirrors	—
Check _____	dash-mounted intake-air restriction indicator	D6
Check _____	oil- and air-pressure warning systems	D13
Check _____	ICU fault codes	D14
Check _____	horn, windshield wipers, and windshield washer	D15
Check _____	heater, defroster, and optional mirror heat controls	D16
Check _____	backup alarm	—
Check _____	panel lights and interior lights	D17
Check _____	exterior lights and reflectors	D18
Check _____	tire pressure	D19
Inspect _____	tire condition	D20
Inspect _____	rims and wheels	D21
Check _____	automatic transmission fluid level	—
Inspect _____	air brake chambers and pushrods	D22
Inspect _____	air brake lines	D23
Inspect _____	slack adjusters	D24
Check _____	air brake system operation	D25
Inspect _____	frame rails (missing bolts), crossmembers (bent or loose)	—
Check _____	mud flaps (aren't damaged, at least 10 inches above the ground, and brackets are secure)	—
Check _____	exhaust system (mounted securely, connected tightly, no signs of leaks such as soot trails)	—
_____	Remove chocks and test service brakes	D26
Inspector _____ Date _____		

**Table 11.1, Daily Pretrip Inspection and Maintenance Checklist**

# Pretrip and Post-Trip Inspections and Maintenance

Procedure Performed (check off)	Weekly Post-Trip Inspections/Checks	Procedure Reference
_____	Manually drain air reservoirs that are equipped with automatic drain valves	—
Inspect _____	batteries and battery cables	W1
Check _____	wheel bearing lubricant level	W2
Inspect _____	steering components	W3
Check _____	serpentine drive belt condition	W4
Check _____	V-belt tension	W5
Inspect _____	seat belts and tether belts	W6
Inspector _____ Date _____		

Table 11.2, Weekly Post-Trip Inspection and Maintenance Checklist

Procedure Performed (check off)	Monthly Post-Trip Inspections/Checks	Procedure Reference
_____	Clean the battery terminals	M1
Inspect _____	radiator hoses and heater hoses	M2
Check _____	fluid level in the hydraulic clutch reservoir (if applicable, and if necessary, fill with DOT 4 brake fluid)	—
Check _____	steering wheel play	M3
Check _____	outer surfaces of the hood and body (for visible surface breaks and damage)	—
Check _____	hood tilt damper (attached at both ends)	—
Inspect _____	brake lining wear	M4
Inspect _____	driveshaft	—
Inspector _____ Date _____		

Table 11.3, Monthly Post-Trip Inspection and Maintenance Checklist

## Pretrip and Post-Trip Maintenance Procedures

### Daily Pretrip Inspection and Maintenance

Whenever equipment requires adjustment, replacement, and/or repair, see the *L-Line and A-Line Workshop Manual* for procedures and specifications. Specific references to the manual will be found where appropriate.

#### 1. Drain manually drained air reservoirs.

Water and oil normally enter the air reservoir in the form of vapor because of the heat generated during compression. After the water and oil condense, drain the resulting emulsion as follows:

- 1.1 Open the wet tank valve. The drain cock or pull chain drain is located on the forward end of the supply air reservoir, which is connected directly to the air compressor. Block the valve open.



**When draining the air reservoir, do not look into the air jets or direct them toward anyone. Dirt or sludge particles may be in the airstream and could cause injury.**

- 1.2 Exhaust the remaining air and moisture from the system by opening the drain cocks on the bottoms of the remaining air reservoirs. Block the valves open.

# Pretrip and Post-Trip Inspections and Maintenance

1.3 Water and oil emulsion often form pockets that will not drain while compressed air is in the reservoirs. Because of these pockets, leave the valves blocked open during the first part of the pretrip inspection.

1.4 If the drained water is cloudy or oily, it may indicate a problem with the compressor. If oil is allowed to contaminate the air dryer, it will not remove the water from the air brake system, which could adversely affect braking.

2. Check the fluid level in the windshield washer reservoir.

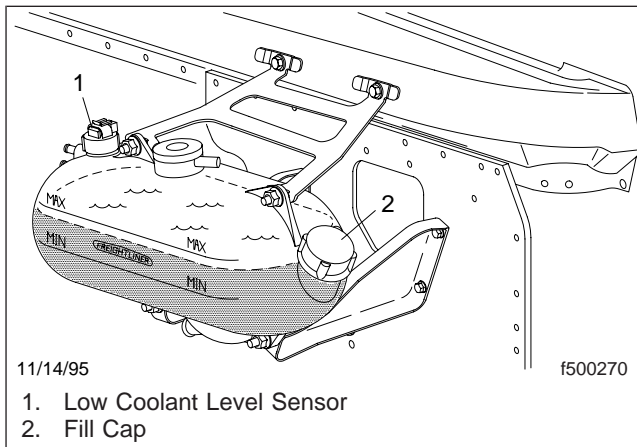
Add washer fluid as needed. Unscrew the cap to add fluid.

## WARNING

Washer fluids may be flammable and poisonous. Do not expose washer fluid to an open flame or any burning material, such as a cigarette. Always comply with the washer fluid manufacturer's recommended safety precautions.

3. Check the coolant level in the surge tank.

See **Fig. 11.1**. If the coolant is low, add a 50/50 mixture of water and the type of antifreeze currently installed in your vehicle. Fill the surge tank with coolant to the MAX line when the tank is cool. If the surge tank was empty, start the engine after refilling and check the level again when the engine is at operating temperature.



**Fig. 11.1, Coolant Level Checking**

## CAUTION

Coolant must be filled to the full line of the surge tank. Low coolant could result in engine overheating, which could cause engine damage.

4. Inspect the radiator and charge air cooler.

4.1 Inspect the radiator and charge air cooler for clogged fins. Use compressed air or water directed from the fan side of the core to backflush any material restricting airflow.

4.2 Inspect the radiator and charge air cooler for damage and accumulated debris. Straighten bent or damaged fins to permit airflow across all areas of the cores.

NOTE: When traveling through areas of high insect concentration, it may be necessary to clean the exterior of the radiator or the charge air cooler core as often as every 200 miles (320 km).

4.3 On vehicles equipped with air conditioning, also inspect and clean the condenser. If clogged, the condenser can restrict airflow through the radiator.

4.4 Check the radiator for leaks. If leaks are found, have the radiator repaired or replaced. See **Group 20** of the *L-Line and A-Line Workshop Manual* for instructions, or take the vehicle to an authorized Sterling dealer.

5. Inspect the engine and chassis wiring.

Check for loose wiring, chafed insulation, and damaged or loose hold-down clamps. Tighten loose wires or hold-down clamps; replace damaged wiring or clamps.

6. Inspect the air intake system for leaks or damage.

## CAUTION

Failure to maintain a sealed air intake system could allow the entry of dirt and contaminants into the engine. This could adversely affect engine performance and result in engine damage.

6.1 Check the intake-air restriction indicator.

# Pretrip and Post-Trip Inspections and Maintenance

- 6.2 Replace the primary filter element in the air cleaner if the yellow signal stays locked at 25 inH<sub>2</sub>O (635 mmH<sub>2</sub>O) for Caterpillar, Detroit Diesel, or Cummins engines, or 20 inH<sub>2</sub>O (508 mmH<sub>2</sub>O) for Mercedes-Benz engines. See **Group 09** of the *L-Line and A-Line Workshop Manual* for filter element replacement instructions, or take the vehicle to an authorized Sterling dealer.

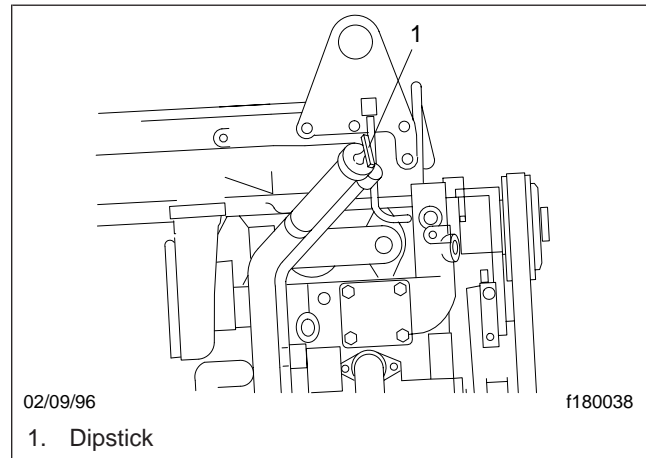
**NOTE:** After replacing the filter element, reset the restriction indicator by pressing the rubber reset button.

- 6.3 Inspect the secondary or safety filter element in the air cleaner when replacing the primary element, and replace it when clogged or dirty. This element should be replaced with every third primary element replacement.
- 6.4 Check the engine air intake piping from the air cleaner to the engine intake. Inspect the piping for loose connections, cracks, torn or collapsed hoses, punctures, and other damage. Tighten loose connections, and have damaged components replaced. Make sure the piping system is airtight so that all intake air passes through the air cleaner.

7. *Check the oil level with the vehicle parked on a level surface, and turned off for at least 20 minutes, for most engines.*

For the DD15 engine, the engine must be shut down for 60 minutes and on a level surface for an accurate oil level reading. Otherwise the engine must be brought up to an operating temperature of 176°F (80°C), shut down, and allowed to sit for 5 minutes on a level surface. Failure to allow the oil to drain back properly as just described, can result in a low oil level reading.

If the oil level is at or below the minimum fill (or "add") mark on the dipstick, add enough oil to maintain the level between the minimum fill (or "add") and the maximum fill (or "full") marks on the dipstick. See **Fig. 11.2**. Engine lube oil must have a sulfated ash level less than 1.0 wt %; currently referred to as CJ-4 oil. Use the proper SAE viscosity rating for the temperature and time of year.



**Fig. 11.2, Oil Level Checking**

## **CAUTION**

**Operating the engine with the oil level below the minimum fill (or "add") mark or above the maximum fill (or "full") mark could result in engine damage.**

8. *Inspect the fuel tanks, fuel lines, and connections for leaks.*
- 8.1 Check that the fuel tanks are secured to their mounting brackets and that the mounting brackets are secured to the frame.
- 8.2 Replace leaking fuel tanks.
- 8.3 If lines or connections are leaking, have them repaired or replaced.
- For repair and/or replacement procedures, see **Group 47** of the *L-Line and A-Line Workshop Manual*, or take the vehicle in to an authorized Sterling dealer.
- 8.4 If equipped with fuel tank shutoff valves, be sure the valves are fully open.

## **WARNING**

**Never operate the engine with the fuel tank shutoff valves partly closed. This could damage the fuel pump, causing sudden loss of engine power, possibly resulting in serious personal injury due to reduced vehicle control.**

9. *Check the fuel level in the fuel tank(s).*

# Pretrip and Post-Trip Inspections and Maintenance

To keep condensation to a minimum, fuel tanks should be filled at the end of each day. Federal regulations prohibit filling a fuel tank to more than 95 percent of its liquid capacity.

## **WARNING**

**Never fill fuel tanks to more than 95 percent of their liquid capacity. This could make them more likely to rupture from impact, possibly causing fire and resulting in serious personal injury or death by burning.**

**Do not mix gasoline or alcohol with diesel fuel. This mixture could cause an explosion, possibly resulting in serious personal injury or death. Do not fill the fuel tanks in the presence of sparks, open flames, or intense heat. These could ignite the fuel, possibly causing severe burns.**

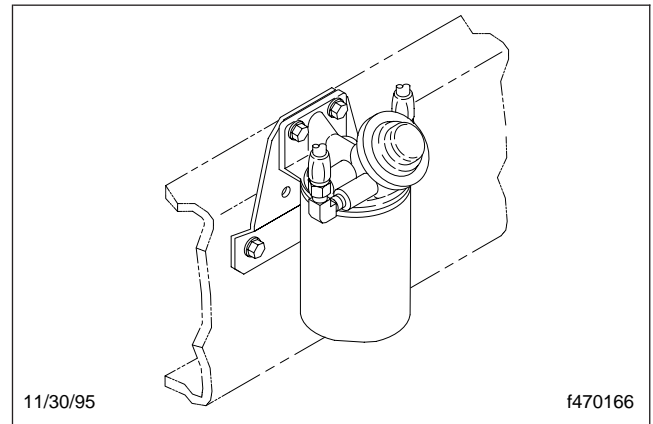
**IMPORTANT:** Use ultralow-sulfur diesel (ULSD) with 15 ppm sulfur content or less, based on ASTM D2622 test procedure. Failure to use ultralow-sulfur diesel fuels may void the warranty on emission components.

- 9.1 Fuel should always be strained or filtered before being put into the tanks. This will lengthen the life of the engine fuel filter and reduce the chances of dirt getting into the engine.
  - 9.2 Before installing the fuel cap, clean the area with a rag, or if necessary, clean the cap with solvent.
  - 9.3 If needed, prime the fuel system. For priming procedures, see the applicable engine manufacturer's manual.
10. *Drain the water from the fuel/water separator.*

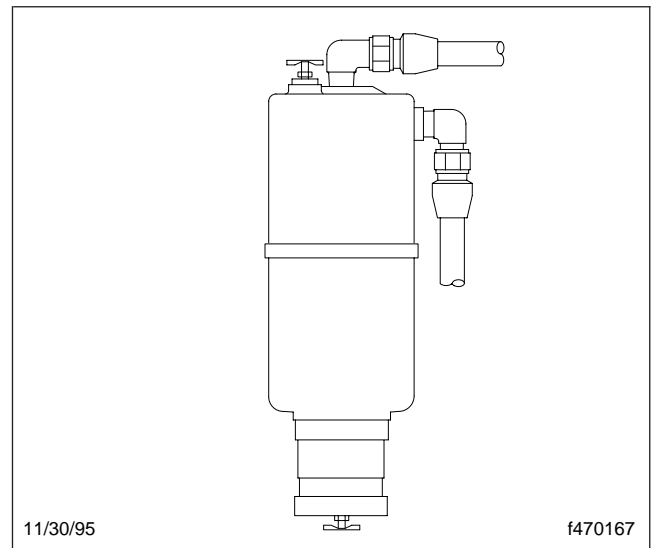
If the engine is equipped with a built-in water separator, place a suitable container under the drain hose, loosen the drain valve, and allow the water to run out. Close the drain valve, taking care not to overtighten it.

*For a Racor Model (Fig. 11.3):* Check the water level in the sight bowl. To drain the water, loosen the valve at the bottom of the bowl two full turns and allow the water to run out. Close and tighten the valve finger-tight. Check the filter element and replace if clogged.

*For a ConMet Model (Fig. 11.4):* Check the water level in the sight bowl (if equipped). To drain the water, loosen the valve at the bottom and allow the water to run out. Close and tighten the valve finger-tight.



**Fig. 11.3, Racor Fuel/Water Separator**



**Fig. 11.4, ConMet Fuel/Water Separator**

**IMPORTANT:** When draining fluid from a fuel/water separator, drain the fluid into an appropriate container and dispose of it properly. Many states now issue fines for draining fuel/water separators onto the ground. On all types of separators, stop draining fluid when you see fuel come out of the separator drain valve.

# Pretrip and Post-Trip Inspections and Maintenance

---

11. *Inspect the front and rear suspension components, including springs, spring hangers, shocks, and suspension brackets.*

- 11.1 Check for broken spring leaves, loose U-bolts, cracks in the suspension brackets, and loose fasteners in the spring hangers and shackles.
- 11.2 Inspect the shock absorbers for loose fasteners and leaks.
- 11.3 Tighten all loose fasteners and have any component(s) replaced that are worn, cracked, or otherwise damaged.
- 11.4 On vehicles with air suspensions, check for leaks. Check air suspension components for cuts and bulges.

12. *Clean the windshield, side, and rear windows, then check the condition of the windshield wiper arms and blades.*

- 12.1 Replace the wiper arms if the wiper blades are not tensioned against the windshield.
- 12.2 Replace damaged or deteriorated wiper blades.

 **WARNING**

**When cleaning windshields and windows, always stand on the ground or on a secure ladder or platform. Use a long-handled window cleaner. Do not use the cab steps, tires, fenders, fuel tanks, engine, or under-hood components to access the windshield or windows. Doing so could cause a fall and result in an injury.**

13. *Check the oil- and air-pressure warning systems.*

- 13.1 Check if the warning systems come on when the ignition is turned on, and if not, have the systems repaired.
- 13.2 Start the engine, then check that the oil- and air-pressure warning systems are operating. The buzzer should stop sounding when the preset minimum is reached. If the air pressure in both systems is above the preset minimum when the engine is started, test the low air pressure warning system by lowering the pressure to below this range, or until the warning system comes on.

The air pressure in both the primary and secondary air reservoir systems must be above 65 psi (448 kPa) on most vehicles. For vehicles with an optional Bendix dryer reservoir module (DRM), the cut-out pressure is 130 psi (896 kPa).

14. *Check the instrumentation control unit (ICU) for fault codes.*

During the ignition sequence, if an active fault is detected in any device that is connected to the ECU, the message display screen will show the active fault codes, one after the other, until the parking brake is released or the ignition switch is turned off. See [Chapter 2](#) for detailed operating instructions for the ICU.

15. *Make sure that the horn, windshield wipers, and windshield washers are operating properly. These devices must be in good working order for safe vehicle operation.*

- 15.1 Make sure that the horn works. If a horn is not working, have it repaired before trip departure.
- 15.2 Check the wiper and washer control on the multifunction turn signal switch. If the wipers and/or washers are not working, have them repaired before trip departure.

16. *During cold weather, make sure the heater, defroster, and optional mirror heat controls are operating properly. If so equipped, turn on the mirror heat switch and make sure the system is working.*

17. *Check the operation of all the panel lights and interior lights.*

Turn on the headlights, dash lights, and four-way flashers and leave them on. If any of the gauge bulbs, the dome light bulbs, or the right- and left-turn indicator bulbs are not working, replace them.

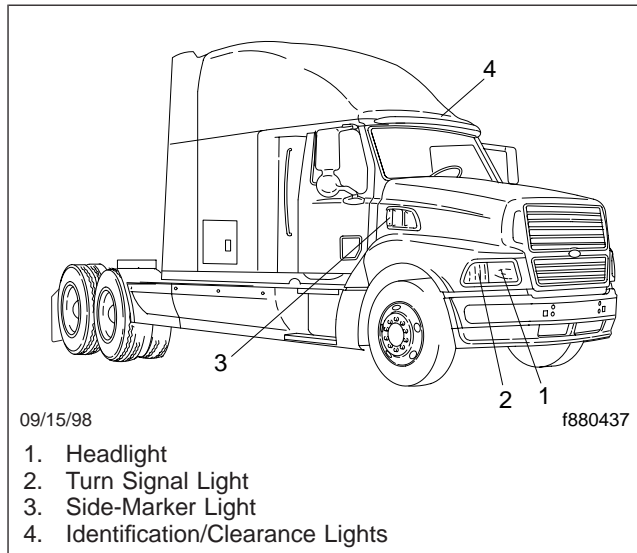
18. *Make sure all the exterior lights are working properly.*

Check that all the lights and reflectors are clean. See [Fig. 11.5](#).

- 18.1 Check that the brake lights, taillights, headlights, parking lights, turn signals, marker lights, identification lights, road lights (if so equipped), and front clearance lights are working properly and are clean.



# Pretrip and Post-Trip Inspections and Maintenance



**Fig. 11.5, Exterior Lights**

- 18.2 Test the high and low beams of the headlights.
  - 18.3 Replace light bulbs or sealed beam units that are not working.
  - 18.4 Be sure all reflectors and lenses are in good condition and are clean. Replace any broken reflectors or lenses.
19. *Check tire inflation pressures using an accurate tire pressure gauge.*
- Tires should be checked when cool. For inflation pressures and maximum loads (per tire) see the tire manufacturer's guidelines.
- 19.1 Be sure valve stem caps are on every tire and that they are screwed on finger-tight.
  - 19.2 Inflate the tires to the applicable pressures if needed. A weekly pressure loss of 4 psi (28 kPa) or more in a tire may indicate damage. The tire should be inspected and, if necessary, repaired or replaced.
  - 19.3 If a tire has been run flat or underinflated, check the wheel for proper lockring and side-ring seating, and possible wheel, rim, or tire damage before adding air.

Moisture inside a tire can result in body ply separation or a sidewall rupture. During tire inflation, compressed air reservoirs

and lines must be kept dry. Use well-maintained inline moisture traps and service them regularly.

## **WARNING**

**Do not operate the vehicle with underinflated or overinflated tires. Incorrect inflation can stress the tires and make the tires and rims more susceptible to damage, possibly leading to rim or tire failure and loss of vehicle control, resulting in serious personal injury or death.**

**IMPORTANT:** The load and cold inflation pressure must not exceed the rim or wheel manufacturer's recommendations, even though the tire may be approved for a higher load inflation. Some rims and wheels are stamped with a maximum load and maximum cold inflation rating. If they are not stamped, consult the rim or wheel manufacturer for the correct tire inflation pressure for the vehicle load. If the load exceeds the maximum rim or wheel capacity, the load must be adjusted or reduced.

20. *Inspect each tire for wear, bulges, cracks, cuts, penetrations, and oil contamination.*
  - 20.1 Check the tire tread depth. If tread is less than 4/32 inch (3 mm) on any front tire, or less than 2/32 inch (1.5 mm) on any rear tire, replace the tire.
  - 20.2 Inspect each tire for bulges, cracks, cuts, and penetrations.
  - 20.3 Inspect each tire for oil contamination. Fuel oil, gasoline, and other petroleum derivatives, if allowed to contact the tires, will soften the rubber and destroy the tire.
21. *Check the wheel nuts or rim nuts for indications of looseness. Examine each rim and wheel component.*
  - 21.1 Remove all dirt and foreign material from the assembly. Dirt or rust streaks from the stud holes, metal buildup around stud holes, or out-of-round or worn stud holes may be caused by loose wheel nuts. See **Fig. 11.6** and **Fig. 11.7**.

# Pretrip and Post-Trip Inspections and Maintenance

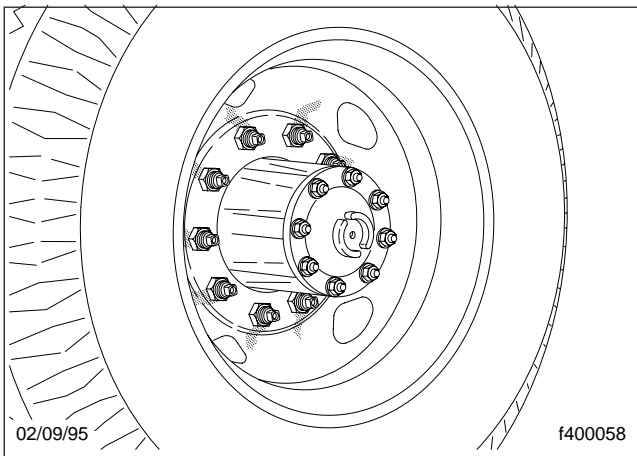


Fig. 11.6, Dirt and Rust Streaks from the Stud Holes

- 21.2 Examine the rim and wheel assembly components (including rims, rings, flanges, studs, and nuts) for cracks, or other damage.

See **Group 33** or **Group 35** of the *L-Line and A-Line Workshop Manual* for service procedures on the studs and hubs, and see **Group 40** in the same manual for wheel and tire servicing, or take the vehicle to an authorized Sterling dealer.

## WARNING

Have any worn or damaged wheel components replaced by a qualified person using the wheel manufacturer's instructions and the wheel industry's standard safety precautions and equipment. Otherwise a vehicle or workshop accident could occur, possibly resulting in serious personal injury or death.

- 21.3 Have broken, cracked, badly worn, bent, rusty, or sprung rings and rims replaced. Be sure that the rim base, lockring, and side ring are matched according to size and type.
- 21.4 Make sure all wheel nuts are tightened 450 to 500 lbf-ft (610 to 678 N-m) for Accuride wheels with unlubricated threads. Use the tightening pattern in **Fig. 11.8** for 10-hole wheels and the tightening pattern in **Fig. 11.9** for 8-hole wheels. See **Group 40** of the *L-Line and A-Line Workshop Manual* for more information.

## CAUTION

Insufficient wheel nut torque can cause wheel shimmy, resulting in wheel damage, stud breakage, and extreme tire tread wear. Excessive wheel nut torque can break studs, damage threads, and crack discs in the stud hole area. Use the recommended torque values and follow the proper tightening sequence.

NOTE: Vehicles operating under severe or adverse conditions should be checked more frequently.

22. Inspect the air brake chamber and the air brake chamber pushrods.

## WARNING

Do not operate the vehicle with the front brakes backed off or disconnected. Backing off or disconnecting the front brakes will not improve vehicle handling and may lead to loss of vehicle control resulting in property damage or personal injury.

- 22.1 Check that the air brake chamber is mounted securely on its mounting bracket, and that there are no loose or missing bolts.
- 22.2 Look for worn clevis pins on brake chamber pushrods, and missing or damaged cotter pins on brake chamber pushrod clevis pins. Replace worn clevis pins and install new cotter pins if necessary.
- 22.3 See if the chamber piston rod is in line with the slack adjuster. Misalignment can cause the piston rod to rub on the non-pressure chamber and cause a dragging brake. See **Group 42** of the *L-Line and A-Line Workshop Manual*.

## CAUTION

If the external breather tube or breather cap is missing or incorrectly installed, road dirt and debris can adversely affect the operation of the brake chamber. Once inside of the chamber, dirt and debris can cause the internal parts of the chamber to deteriorate faster.

# Pretrip and Post-Trip Inspections and Maintenance

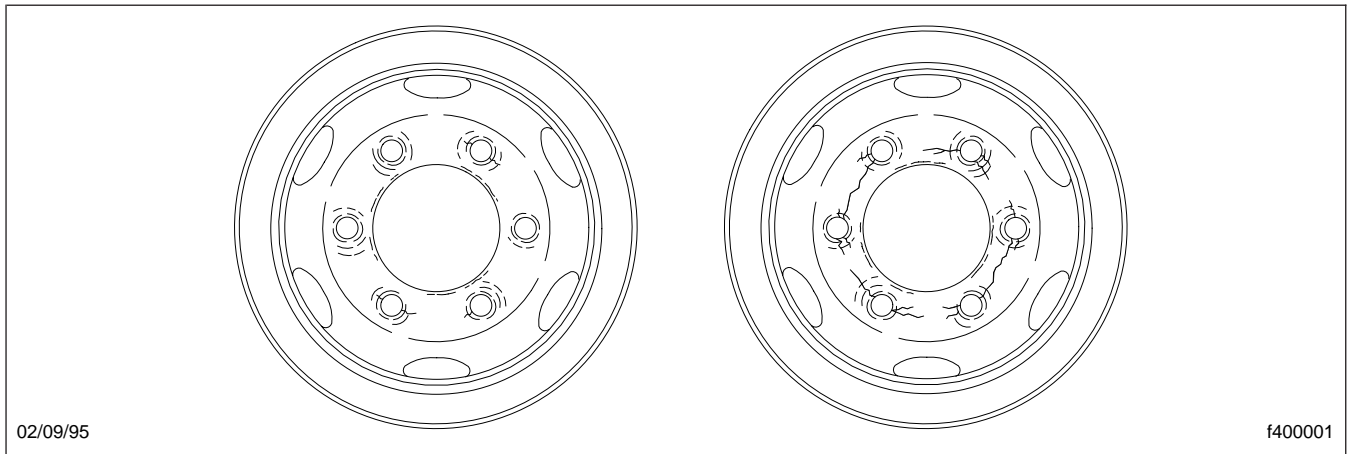


Fig. 11.7, Worn Stud Holes

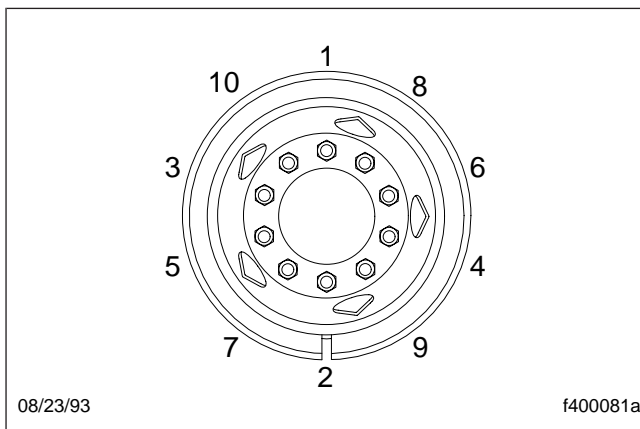


Fig. 11.8, Tightening Pattern, 10-Hole Wheels

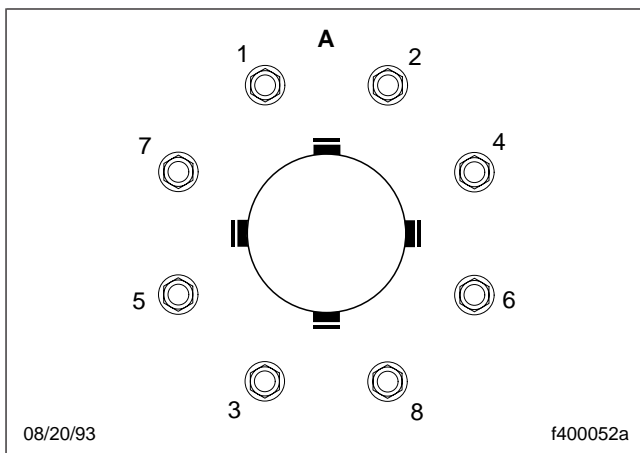


Fig. 11.9, Tightening Pattern, 8-Hole Wheels

- 22.4 Inspect the exterior surfaces of the chamber for damage. Make sure that breather holes in the non-pressure section(s) are open and free of debris. See **Group 42** of the *L-Line and A-Line Workshop Manual* to replace any damaged parts.

## DANGER

**Do not loosen or remove the parking brake clamp ring for any purpose. The parking/emergency brake section of the brake chamber is not intended to be serviced. Serious injury or death may result from sudden release of the power spring.**

- 22.5 On all parking brake installations, make sure the end cover cap or dust plug is securely snapped into place. See [Fig. 11.10](#).

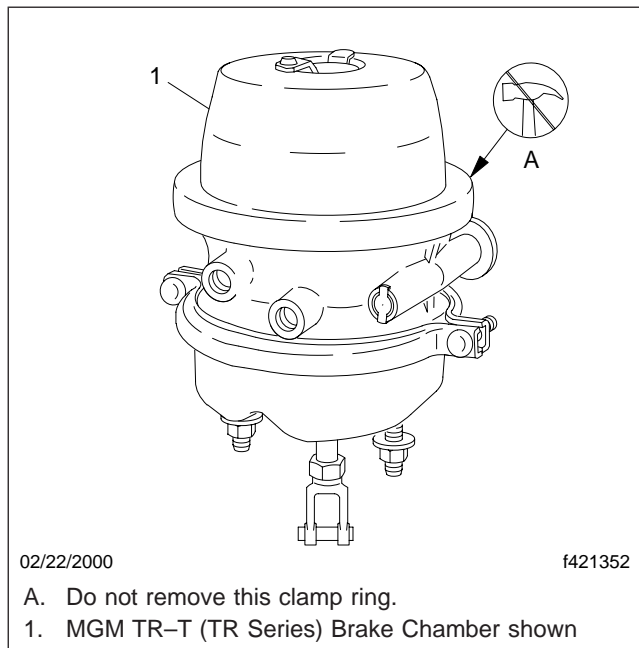
**NOTE:** On most MGM parking brake chambers equipped with an integral release bolt, an end cover cap is installed over the release bolt.

- 22.6 Check for rusted connections, missing snap rings, and damaged camshaft grease seals. Have damaged or missing parts repaired or replaced.

### 23. *Inspect the air brake lines.*

- 23.1 Check the clearance between the hoses and the exhaust manifold or other hot spots. Excessive heat will cause material

# Pretrip and Post-Trip Inspections and Maintenance



**Fig. 11.10, Parking Brake Chamber Clamp**

in the hoses to deteriorate rapidly or become brittle. Provide at least 6 inches (150 mm) of clearance. More clearance is recommended if the hose is located above the heat source.

- 23.2 Check for kinks, dents, or swelling of the hoses. If damaged, have the hose replaced with the same size and type.

**NOTE:** Do not route the hose on top of anything likely to be stepped on.

- 23.3 Check for damage to hoses located near moving parts, such as drivelines, kingpins, suspensions, and axles. If moving parts are catching or pinching the lines, correct as needed.
- 23.4 Check for hose damage caused by abrasion. If abraded, have the hose replaced. Check for the cause of abrasion, such as loose or damaged hose clamps. Have the clamps repaired or replaced as needed.
- 23.5 Observe the hose cover condition, especially hoses exposed to water splash and ice. If dried out or ragged (the wire or liner is showing through the cover), have the hose(s) replaced.

- 23.6 Inspect the air tubing, especially tubing made of nylon. In cold weather, nylon tubing is sensitive to damage, such as nicks or cuts. Have nicked or cut tubing replaced, even if it is not leaking.
- 23.7 Check for kinked or twisted hoses. A seven-percent twist in the hose can reduce its life by up to 90 percent. A twisted hose under pressure tends to untwist, which may loosen the fitting. Reconnect hoses that are twisted.

**NOTE:** The front brake lines flex continuously in vehicle operation, so they require special examination. Give particular attention to the areas near where they connect to the front air brake chambers. This inspection requires two people, one in the driver seat and another to inspect the brake line connections at the wheels.

- 23.8 Both wheel air lines must be inspected with the emergency brake set, engine idling, air pressure at 80 to 90 psi (550 to 620 kPa), and the brake pedal held down.
- 23.9 Turn the wheels to full lock in one direction and inspect both air lines where they connect to the air chambers, then turn the wheels to full lock in the other direction and inspect both lines. If a hose is leaking, have it replaced.

**IMPORTANT:** ABS-equipped vehicles operating in regions where especially corrosive ice removal chemicals are used may experience higher than normal rotor corrosion. Tone rings should be routinely inspected for corrosion. Severe corrosion of the integral ABS tone ring may cause the ABS warning lamp in the dash to illuminate due to false wheel speed readings. If the ABS warning lamp illuminates at any time other than at vehicle start-up, have the problem repaired immediately.

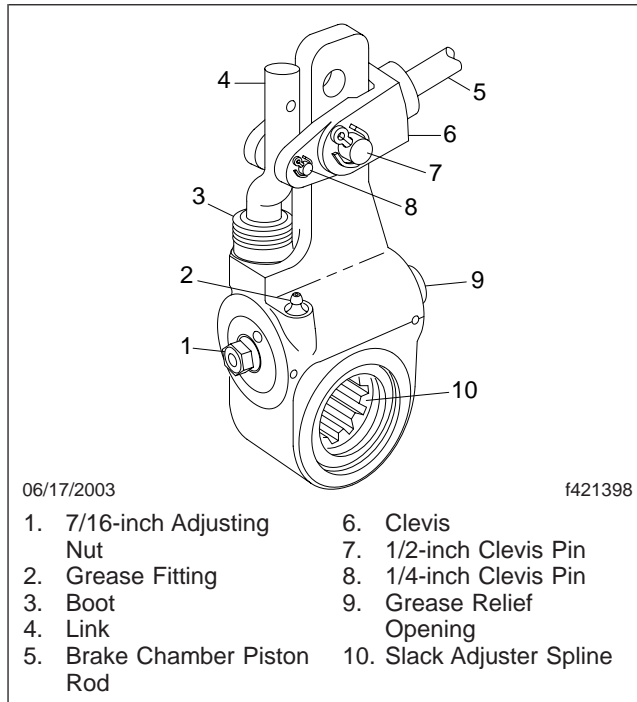
## 24. *Inspect the slack adjusters.*

- 24.1 *Meritor Slack Adjusters:* Check the boot for cuts, tears, or other damage. Have it replaced if necessary.

# Pretrip and Post-Trip Inspections and Maintenance

24.2 *Gunite Slack Adjusters:* Inspect the slack adjuster for any signs of damage. If damaged, have the slack adjuster replaced.

Inspect the slack adjuster boot for cuts or tears. If the boot is damaged, have it replaced. See **Fig. 11.11**.



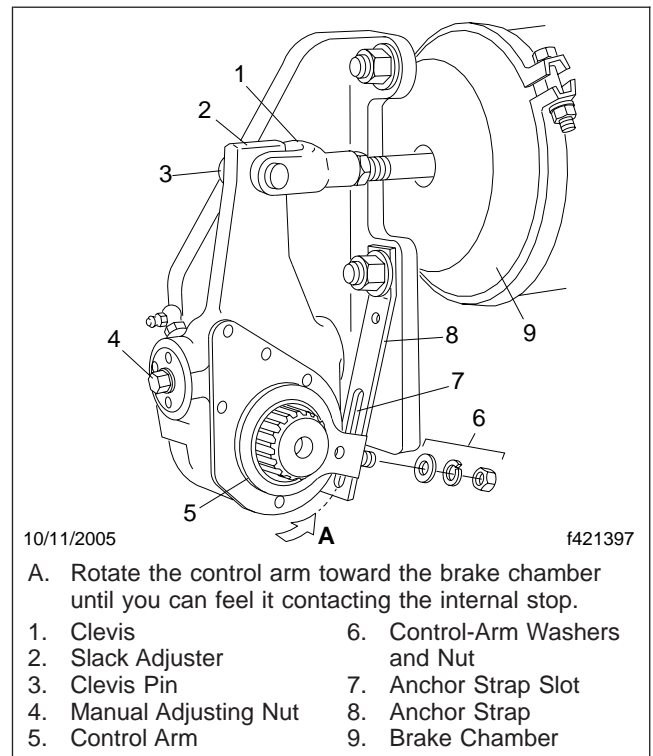
**Fig. 11.11, Gunite Automatic Slack Adjuster**

24.3 *Haldex Slack Adjusters:* Inspect each slack adjuster and anchor strap for damage. See **Fig. 11.12**. Have any damaged components replaced.

25. Check the air brake system for proper operation.

25.1 Check the air governor cut-in and cut-out pressures as follows.

Run the engine at fast idle. The air governor should cut out the air compressor at approximately 120 psi (827 kPa). With the engine idling, apply the brake pedal several times. The air governor should cut in the air compressor at approximately 100 psi (689 kPa). If the air governor does not cut in and out as described above, it must be adjusted to these specifications. If the



10/11/2005

f421397

A. Rotate the control arm toward the brake chamber until you can feel it contacting the internal stop.

- |                         |                                |
|-------------------------|--------------------------------|
| 1. Clevis               | 6. Control-Arm Washers and Nut |
| 2. Slack Adjuster       | 7. Anchor Strap Slot           |
| 3. Clevis Pin           | 8. Anchor Strap                |
| 4. Manual Adjusting Nut | 9. Brake Chamber               |
| 5. Control Arm          |                                |

**Fig. 11.12, Haldex Automatic Slack Adjuster**

air governor cannot be adjusted or repaired, replace it before operating the vehicle.

25.2 Check the air pressure buildup time as follows.

With the air system fully charged to 120 psi (827 kPa), make one full brake application and note the air pressure reading on the gauge. Continue to reduce the air pressure by moderate brake applications to a maximum of 90 psi (620 kPa), then run the engine at governed rpm. If the time required to raise the air pressure to 120 psi (827 kPa) (from the pressure noted after one brake application) is more than 30 seconds, eliminate any leaks or replace the air compressor before operating the vehicle.

25.3 Check the air pressure reserve as follows.

With the air system fully charged to 120 psi (827 kPa), stop the engine and note the air pressure. Then make one full brake

# Pretrip and Post-Trip Inspections and Maintenance

application and observe the pressure drop. If it drops more than 25 psi (172 kPa), all areas of leakage must be eliminated before operating the vehicle.

- 25.4 Check the air leakage in the system as follows.

With the parking brake (spring brake) applied, the transmission out of gear, and the tires chocked, charge the air system until cut-out pressure of 120 psi (827 kPa) is reached.

With the service brakes released, shut down the engine, wait 1 minute and note the air pressure gauge reading. Observe the air pressure drop in psi (kPa) per minute.

Charge the air system until cut-out pressure of 120 psi (827 kPa) is reached. With the parking brakes released and the service brake applied, shut down the engine, wait 1 minute and note the air pressure gauge reading. Observe the air pressure drop in psi (kPa) per minute.

If leakage exceeds the limits shown in **Table 11.4**, repair all areas of leakage before driving the vehicle.

Maximum Allowable Service Brake Air Leakage		
Description	Air Leakage in psi (kPa) Per Minute	
	Released	Applied
Truck or Tractor Only	2 (14)	3 (21)
Truck or Tractor w/Single Trailer	3 (21)	4 (28)
Truck or Tractor w/Two Trailers	5 (35)	6 (42)

**Table 11.4, Maximum Allowable Service Brake Air Leakage**

26. *Test the service brakes.*

When starting to move the vehicle and before picking up speed, test the brakes with the foot pedal and parking brake control valve (yellow knob) to be sure they will bring the vehicle to a safe stop.

## Weekly Post-Trip Inspection and Maintenance



### WARNING

**Battery posts, terminals, and related accessories contain lead and lead compounds, chemicals known to the State of California to cause cancer and reproductive harm. To prevent possible personal injury, always wash your hands after handling battery parts and related accessories.**

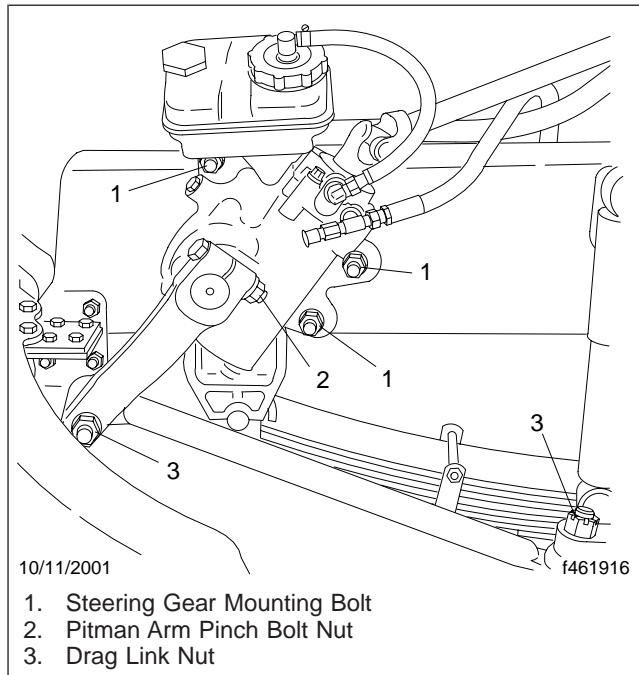
1. *Inspect the batteries and battery cables.*
  - 1.1 Access the batteries. Be sure the battery hold-down is secure. If it is loose, tighten the hold-down bolts; if it is broken, replace it.
  - 1.2 If the battery is equipped with a built-in hydrometer, examine the hydrometer. If a green dot shows in the sight glass, the battery is sufficiently charged.  
  
If the sight glass is dark, the charge is low and the battery must be recharged.  
  
If the sight glass is clear, the battery has a low level of electrolyte and must be replaced.

2. *Check the level of the wheel bearing lubricant in the hub cap at each end of the front axle.*  
  
If needed, fill the hubs to the level indicated on the hub cap. See **Group 35** of the *L-Line and A-Line Maintenance Manual*, for recommended lubricants.

**IMPORTANT:** Before removing the fill plug, always clean the hub cap and plug.

3. *Examine the steering components.*  
  
See **Fig. 11.13**. If repairs are needed, see **Group 46** of the *L-Line and A-Line Workshop Manual* for instructions, or take the vehicle to an authorized Sterling dealer.
  - 3.1 Check the mounting bolts and pitman arm nut for tightness.
  - 3.2 Check the drag link nuts for missing cotter pins.

# Pretrip and Post-Trip Inspections and Maintenance



**Fig. 11.13, Steering Gear Fasteners**

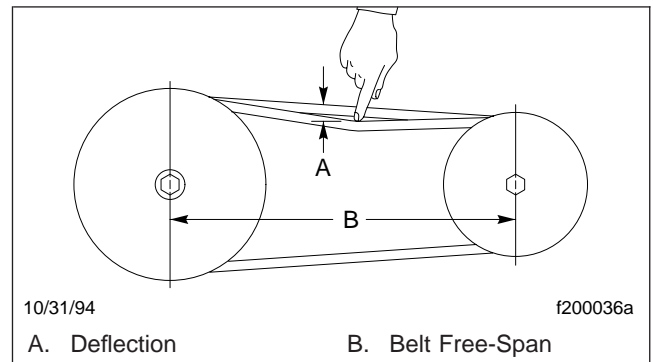
- 3.3 Inspect the steering drive shaft and steering linkage for excessive looseness, or other damage.
- 3.4 Tighten loose nuts and have damaged parts replaced as needed.
4. *Check the condition of the serpentine drive belt.*  
Look for signs of glazing, wear (frayed edges), damage (breaks or cracks), or oil contamination. If a belt is glazed, worn, damaged, or oil soaked, have the belt replaced, following the instructions in **Group 01** of the *L-Line and A-Line Workshop Manual*.

## CAUTION

**Do not drive with a serpentine belt that is visibly worn or damaged. If it fails, the lack of coolant flow could rapidly cause progressive damage to engine components.**

5. *Check the drive belt for proper tension.*  
Use your index finger to apply force at the center of the belt free-span. See **Fig. 11.14**. There is no adjustment for belt tension on engines with automatic belt tensioners. If there is not proper ten-

sion, have the belt tensioner replaced. See **Group 01** of the *L-Line and A-Line Workshop Manual* for instructions, or take the vehicle to an authorized Sterling dealer.



**Fig. 11.14, Checking Belt Tension**

6. *Inspect the seat belts and tether belts.*

## WARNING

**Inspect and maintain seat belts as instructed below. Worn or damaged seat belts could fail during a sudden stop or crash, possibly resulting in serious injury or death.**

**IMPORTANT:** Seat belts have a finite life which may be much shorter than the life of the vehicle. Regular inspections and replacement as needed are the only assurance of adequate seat belt security over the life of the vehicle.

**NOTE:** When any part of a seat belt needs replacement, the entire seat belt must be replaced, both retractor and buckle side.

- 6.1 Check the web for fraying, cuts, or extreme wear, especially near the buckle latch plate and in the D-loop guide area.
- 6.2 Check the web for extreme dirt or dust and for severe fading from exposure to sunlight.
- 6.3 Check the buckle and latch for operation and for wear or damage.
- 6.4 Check the Komfort Latch for function and cracks or other damage.

# Pretrip and Post-Trip Inspections and Maintenance

---

- 6.5 Check the web retractor for function and damage.
- 6.6 Check the mounting bolts for tightness and tighten any that are loose.

- 2.3 Tighten hose clamps as necessary, but do not overtighten, as hose life can be adversely affected.
- 2.4 Be sure the hose support brackets are securely fastened. Make sure the hoses are not located near sources of wear, abrasion, or high heat.

## Monthly Post-Trip Inspection and Maintenance

 **WARNING**

**Battery posts, terminals, and related accessories contain lead and lead compounds, chemicals known to the State of California to cause cancer and reproductive harm. To prevent possible personal injury, always wash your hands after handling battery parts and related accessories.**

- 1. *Clean the batteries.*
  - 1.1 Remove any corrosion from the hold-down and the top of the battery.

 **CAUTION**

**Take care to keep the vent plugs tight so that the neutralizing solution does not enter any of the battery cells and damage the battery.**

- 1.2 Use a soda solution to neutralize the acid present, then rinse off the soda solution with clean water.
- 1.3 If the battery posts or cable terminals are corroded, disconnect the terminals from the posts. Clean them with a soda solution and a wire brush. After cleaning, connect the terminals to the battery posts, then apply a thin coat of petroleum jelly to the posts and terminals to help retard corrosion.
- 2. *Inspect the radiator and heater hoses, including the clamps and support brackets.*
  - 2.1 Make sure the radiator inlet and outlet hoses are pliable and are not cracking or ballooning. Replace hoses that show signs of cracking, weakening, or ballooning.
  - 2.2 Make sure the heater hoses are pliable and are not cracking or ballooning. Replace hoses that show signs of cracking, weakening, or ballooning.

**IMPORTANT:** Replace all hoses, including heater hoses, at the same time. Service-type knitted or braided yarn-reinforced neoprene hose is acceptable. Silicone hoses having an extended service life can be substituted for the reinforced neoprene type. See the Freightliner *Service Parts Catalog* or contact your Sterling dealer.

- 3. *Check the steering wheel for excessive play.*
  - 3.1 Start the engine. With the front tires straight ahead, turn the steering wheel until motion is observed at the front wheels.
  - 3.2 Align a reference mark on a ruler, then slowly turn the steering wheel in the opposite direction until motion is again detected at the wheels.
  - 3.3 Check the lash (free play) at the rim of the steering wheel. See local/federal regulations for acceptable ranges of lash.  
  
If there is excessive lash, check the steering system for wear or incorrect adjustment of the linkage and steering gear before operating the vehicle.
- 4. *Check the brake lining wear on all vehicles, including those with automatic slack adjusters. Proper brake operation is dependent on periodic maintenance and inspection of the brake linings.*
  - 4.1 Check that brake linings are free of oil and grease.
  - 4.2 Inspect the thickness of the brake linings. If the axle assembly is equipped with a dust shield or backing plate, remove the inspection plugs. If *any* brake linings are worn to less than approximately 1/4 inch (6.4 mm) at the thinnest point, have the linings replaced on *all* brake assemblies on that axle. See **Group 42** of the *L-Line*



# Pretrip and Post-Trip Inspections and Maintenance

---

*and A-Line Workshop Manual* for lining replacement instructions and camshaft end-play inspection.

- 4.3 Check the brake drums for wear and cracks.
- 4.4 Check that the inspection plugs in the dust shields or backing plates, if so equipped, are installed.

# 12

## Cab Appearance

---

Cab Washing and Polishing .....	12.1
Care of Fiberglass Parts .....	12.1
Care of Chrome Parts .....	12.1
Dashboard Care .....	12.1
Vinyl Upholstery Cleaning .....	12.1
Velour Upholstery Cleaning .....	12.2
Reflective Material .....	12.3
Cleaning the Engine .....	12.3
Cleaning Exterior Plastic .....	12.3
Cleaning Exterior Lights .....	12.3
Cleaning and Maintaining Safety Belts .....	12.3
Underbody .....	12.3
Leather Upholstery Cleaning .....	12.3
Woodtone Trim .....	12.4
Inside Windows .....	12.4
Cleaning Lights .....	12.4
Cleaning Mirrors .....	12.4

# Cab Appearance

---

## Cab Washing and Polishing

To protect the finish of your new vehicle, follow these guidelines carefully:

- During the first 30 days, rinse your vehicle frequently with water. If the vehicle is dirty, use a mild liquid soap. Do not use detergent.
- During the first 30 days, do not use anything abrasive on your vehicle. Brushes, chemicals, and cleaners may scratch the finish.
- During the first 120 days, do not wax your vehicle.

To extend the life of your vehicle's finish, follow these guidelines:

- Avoid washing your vehicle in the hot sun.
- Always use water. After the cab is completely washed, dry it with a towel or chamois.
- Do not dust painted surfaces with a dry cloth, as this will scratch the paint.
- Do not remove ice or snow from a painted surface with a scraper of any sort.
- To prevent damage to the finish, wax it regularly. Before waxing, if the finish has become dull, remove oxidized paint using a cleaner specifically designed for this purpose. Remove all road tar and tree sap before waxing. Sterling recommends that a quality brand of cleaner or cleaner-polish and polishing wax be used.
- Do not let diesel fuel or antifreeze stand on a painted surface. If either should occur, rinse the surface off with water.
- To prevent rust, have any nicks or other damage on the finish touched up as soon as possible.
- Park your vehicle in a sheltered area whenever possible.

## Care of Fiberglass Parts

Wash unpainted fiberglass air fairings and shields monthly with a mild detergent, such as dishwashing liquid. Avoid strong alkaline cleansers.

Apply a wax specifically designed for fiberglass.

## Care of Chrome Parts

To prevent rust, keep chrome parts clean and protected at all times. This is especially important during winter driving and in coastal areas where there is exposure to salt air.

When cleaning chrome parts, use clean water and a soft cloth or sponge. A mild detergent may also be used.

Sponge gently, then rinse. If necessary, use a non-abrasive chrome cleaner to remove stubborn rust or other material. Do not use steel wool.

To help protect the chrome after cleaning, apply a coat of polishing wax to the surface. Never use wax on parts that are exposed to high heat, such as exhaust pipes.

## Dashboard Care

Periodically wipe the dashboard with a water-dampened cloth. A mild detergent can be used, but avoid using strong detergents.



### CAUTION

**Do not use Armor-All Protectant®, STP Son-of-a-Gun®, or other equivalent treatments. These cleaners contain vinyl plasticizers that can cause stress crazing in the interior plastic panels, which can result in cracking of the panels.**

## Vinyl Upholstery Cleaning

To prevent soiling, frequent vacuuming or light brushing to remove dust and dirt is recommended. Harsh cleaning agents can cause permanent damage to vinyl upholstery. To preserve the upholstery and prevent damage, carefully review the following sections for recommended cleaning procedures. Waxing or refinishing improves soil resistance and cleanability for all vinyls. Any hard wax, such as that used on automobiles, may be used.

## Ordinary Dirt

Wash the upholstery with warm water and mild soap, such as saddle or oil soap. Apply soapy water to a large area and allow to soak for a few minutes, then rub briskly with a cloth to remove the dirt. This can be repeated several times, as necessary.

If dirt is deeply imbedded, use a soft bristle brush after applying the soap.

If dirt is extremely difficult to remove, wall-washing preparations normally found around the home can be used. Powdered cleaners, such as those used for sinks and tiles, are abrasive and must be used with caution as they can scratch the vinyl or give it a permanent dull appearance.

## Chewing Gum

Harden the gum with an ice cube wrapped in a plastic bag, then scrape it off with a dull knife. Any remaining traces of gum can be removed with an all-purpose light oil (peanut butter will also work) and wiped off.

## Tars, Asphalts, and Creosote

Each of these items stains vinyl after prolonged contact. They should be wiped off immediately and the area carefully cleaned, using a cloth dampened with naphtha.

## Paint, Shoe Heel Marks

Paint should be removed immediately. Do not use paint remover or liquid-type brush cleaner on vinyl. An unprinted cloth, dampened with naphtha or turpentine may be used. Use care to prevent contact with parts of the upholstery that are not vinyl.

## Sulfide Stains

Sulfide compounds, such as those found in eggs and some canned goods, can stain after prolonged contact with vinyl. These stains can be removed by placing a clean, unprinted piece of cloth over the spotted area and pouring a liberal amount of 6 percent hydrogen peroxide onto the cloth. Allow the saturated cloth to remain on the spot for 30 to 60 minutes. For stubborn spots, allow the hydrogen-peroxide saturated cloth to remain on the area overnight. Use caution to prevent the solution from seeping into the seams, or it will weaken the cotton thread.

## Nail Polish and Nail Polish Remover

Prolonged contact with these substances causes permanent damage to vinyl. Careful blotting immediately after contact minimizes damage. Do not spread the liquid during removal.

## Shoe Polish

Most shoe polishes contain dyes which penetrate vinyl and stain it permanently. Shoe polish should be wiped off as quickly as possible using naphtha or lighter fluid. If staining occurs, try the procedure used for sulfide stains.

## Ball Point Ink

Ball point ink can sometimes be removed if rubbed immediately with a damp cloth, using water or rubbing alcohol. If this does not work, try the procedure used for sulfide stains.

## Miscellaneous

If stains do not respond to any of the treatments described above, it is sometimes helpful to expose the vinyl to direct sunlight for up to 30 hours. Mustard, ball point ink, certain shoe polishes, and dyes often bleach out in direct sunlight, leaving the vinyl undamaged.

## Velour Upholstery Cleaning

To prevent soiling, frequent vacuuming or light brushing to remove dust and dirt is recommended. Spot clean with a mild solvent or an upholstery shampoo, or the foam from a mild detergent. When using a solvent or a dry-cleaning product, follow the instructions carefully, and clean only in a well-ventilated area. Avoid any product that contains carbon tetrachloride or other toxic materials. With either method, pretest a small area before proceeding. Use a professional upholstery cleaning service when extensive cleaning is needed.

## Grease and Oil-Based Stains

Dampen a small absorbent cloth with dry-cleaning solvent or spot remover. Apply the cloth carefully to the spot from the outer edge to the center. Pat and blot the spot with a clean, dry cloth. Repeat several times, as necessary, turning the cloths so that the stain does not redeposit on the fabric.

## Sugar and Water-Based Stains

Apply water-based detergent or cleaner, working in circular motions. Pat and blot as dry as possible. Repeat, if necessary, before drying thoroughly.

# Cab Appearance

---

## Chewing Gum or Wax

Harden the gum or wax with an ice cube wrapped in a plastic bag, then scrape it off with a dull knife. Excess wax can be absorbed by placing a thick white blotter over the wax and heating with a warm (not hot) iron. Remove the remainder by using the procedure for grease and oil-based stains.

## Mildew

Brush the dry fabric with a soft brush. Sponge with detergent, and blot. If the fabric is colorfast, dilute a teaspoon of bleach in one quart (one liter) of cool water. Apply with a swab, directly on the mildew stain. Dab repeatedly with clear, cool water, and blot dry.

## Reflective Material

Using warm water and detergent, clean by hand with a sponge, cloth or soft brush and rinse thoroughly. Automatic truck wash machines are also acceptable. When using a high-pressure spray nozzle, hold the nozzle at least 12 inches away from the surface and less than a 45 degree angle to the surface to avoid lifting the reflective material from the truck.

## Cleaning the Engine

Cover the underhood electrical connections and terminals of your vehicle when cleaning the engine compartment. Avoid spraying or splashing cleaning solvents or detergent solutions on the terminals and connections. After the cleaning is completed and with the engine not running, remove the protective cleaning coverings. Exposing electrical connections and terminals to cleaning solvents and detergent solutions over a period of time can corrode them and result in electrical system damage and malfunctions.

## Cleaning Exterior Plastic

Use vinyl cleaner for routine cleaning. Clean with a tar remover if necessary. Do not clean plastic parts with thinners, solvents or petroleum-based cleaners.

## Cleaning Exterior Lights

Wash with the same detergent as the exterior of your vehicle. Use glass cleaner or tar remover if necessary.

To avoid scratching the lights, do not use a dry paper towel, chemical solvents or abrasive cleaners.

## Cleaning and Maintaining Safety Belts

Clean the safety belts with a mild soap solution recommended for cleaning upholstery or carpets. Do not bleach or dye the belts, because the belt webbing could be weakened.

## Underbody

Flush the complete underside of the vehicle frequently. Keep body drain holes unplugged. Inspect for road damage.

## Leather Upholstery Cleaning

For routine cleaning, wipe the surface with a soft, damp cloth. For more thorough cleaning, wipe the surface with a mild soap.

If the leather cannot be completely cleaned using a mild soap and water solution, the leather may be cleaned using a commercially available cleaning product "Tanners Preserve Leather Cleaner" and a 3M "Type T" scrubbing pad by using the following steps.

**IMPORTANT:** The type of scrubbing pad is very critical because the common 3M "Scotch Brite" green pad is too aggressive and will damage the leather surface.



**Do not use household cleaners, glass cleaner, alcohol solutions or cleaner intended for vinyl, rubber or plastics. These products can damage the leather.**

**IMPORTANT:** In some instances, color or dye transfer can occur when wet clothing (wool, denim, leathers or other noncolorfast garments) comes in contact with leather upholstery. If this occurs, the leather should be cleaned immediately to avoid permanent staining.

"Tanners Preserve Leather Cleaner" (product number AS-300) is available from "First Brands" by calling

1-800-726-1001. This product may also be available at many local automotive after market stores.

3M "Type T" Clean And Finish Scrubbing Pads (UPC 04011-01276) are available through your local 3M distributor. Call 1-800-742-9649 for the nearest distributor in your area.

1. Spray a small amount of the leather cleaner on the pad and rub the area to be cleaned with the pad using a circular motion. Only clean one-quarter of the area at a time. For heavily soiled areas, spray the cleaner directly onto the leather (two squirts should be adequate) and rub with the pad. Repeat if necessary.
2. Using a soft, damp cloth, remove the loosened dirt and foam.
3. Dry with a soft cloth.

## Woodtone Trim

Wipe stains with a soft cloth and a multi-purpose cleaning solution.

## Inside Windows

Use glass cleaner for the inside windows if they become fogged.

## Cleaning Lights

Dirty lights reduce night vision distances and oncoming drivers cannot see your vehicle as soon. Keep your lights clean at all times.

## Cleaning Mirrors

Do not clean your mirrors with a dry cloth or abrasive materials. Use a soft cloth and mild detergent and water. Be careful when removing ice from outside mirrors because you may damage the reflective surface.

# 13

## In an Emergency

---

Hazard Warning Lights .....	13.1
Fire Extinguisher .....	13.1
Emergency Kit, Optional .....	13.1
Emergency Starting with Jumper Cables .....	13.1
Towing .....	13.2
Fire in the Cab .....	13.4

# In an Emergency

---

## Hazard Warning Lights

The hazard warning light switch tab is located on the left side of the steering column. To operate the hazard lights, press the orange control once. All of the turn signal lights and both of the indicator lights on the control panel will flash.

To cancel the hazard warning lights, press the control again.

## Fire Extinguisher

A fire extinguisher is located in the cab by the driver's door.

## Emergency Kit, Optional

An optional emergency kit package is located between the seats, at the front of the center console, if the vehicle does not have a sleeper compartment. If there is a sleeper compartment, the emergency kit is located elsewhere, depending on vehicle configuration. The package includes one or more of each of the following: first aid kit, a reflective vest, and a triangular reflector and flare kit.

If there is an emergency while driving, cautiously pull off the road, paying attention to other traffic. Turn on the hazard warning lights. Place the flares and reflector along the side of the road, to alert other drivers that an emergency situation exists.

### WARNING

**Use extreme care when placing flares in emergency situations that involve exposure to flammable substances such as fuel. An explosion or fire could occur causing serious personal injury.**

## Emergency Starting with Jumper Cables

When using jumper cables, use the following instructions.

### WARNING

**Batteries release explosive gas. Do not smoke when working around batteries. Put out all flames and remove all sources of sparks or intense heat in the vicinity of the battery. Do not allow the ve-**

**hicles to touch each other. Do not lean over the batteries when making connections, and keep all other persons away from the batteries. Failure to follow these precautions could lead to severe personal injury as a result of an explosion or acid burns.**

### CAUTION

**Make sure both starting systems have the same voltage outputs, and avoid making sparks. Otherwise the vehicle charging systems could be severely damaged. Also, do not attempt to charge isolated, deep-cycle batteries with jumper cables. Follow the battery manufacturer's instructions when charging deep-cycle batteries.**

On vehicles equipped with optional jump-start posts, attach the positive cable clamp to the positive post instead of to the battery, and attach the negative cable clamp to the negative post.

### CAUTION

**Connecting the jumper cables to the vehicle frame rail or to the engine block can cause severe damage to the engine wiring.**

On vehicles without jump-start posts, the positive cable clamp can be attached to the starter positive lug terminal.

1. Apply the parking brakes and turn off the lights and all other electrical loads.
2. Connect an end of one jumper cable to the positive terminal of the booster battery (or jump-start post, if equipped), and connect the other end of the cable to the positive terminal of the discharged battery (or jump-start post, if equipped).

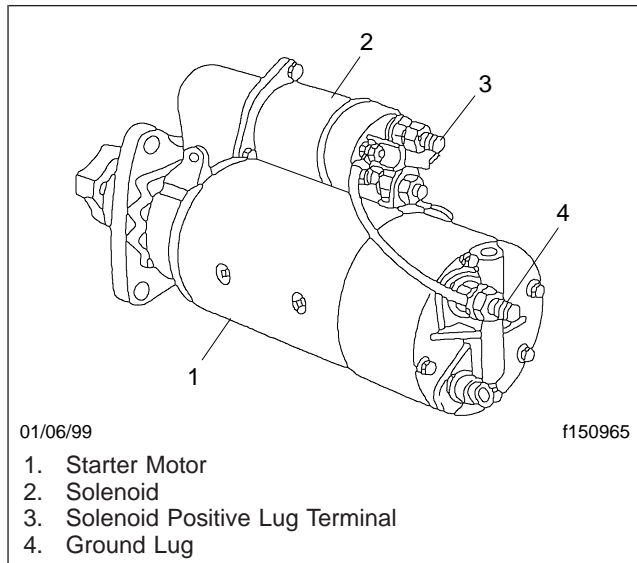
### WARNING

**Do the next step exactly as instructed and do not allow the clamps of one cable to touch the clamps of the other cable. Otherwise, a spark could occur near a battery, possibly resulting in severe personal injury from explosion and acid burns.**

3. Connect one end of the second jumper cable to the negative terminal of the booster battery and connect the other end to the negative jump-start post or the starter ground lug. The starter ground



lug (see **Fig. 13.1**) is the best location. Do *not* use the frame rail or the engine block as a ground.



**Fig. 13.1, Delco Remy 42-MT Starter**

**NOTE:** It may be easier to access the starter ground lug by routing the jumper cable underneath the vehicle. If the starter ground lug is not accessible, connect to the negative battery post of the discharged battery.

4. Start the engine of the vehicle with the booster batteries, and let the engine run a few minutes to charge the batteries of the other vehicle.
5. Attempt to start the engine of the vehicle with the batteries receiving the charge. Do not operate the starter longer than 30 seconds, and wait at least two minutes between starting attempts to allow the starter to cool.
6. When the engine starts, let it idle a few minutes.

## **! WARNING**

**Do the next step exactly as instructed and do not allow the clamps of one cable to touch the clamps of the other cable. Otherwise, a spark could occur near a battery, possibly resulting in severe personal injury from explosion and acid burns.**

7. Disconnect the grounded cable from the vehicle; then disconnect the other end of the cable from the negative terminal of the booster battery.
8. Disconnect the remaining cable from the newly charged battery or jump-start post first, then disconnect the other end.

## Towing

When it is necessary to tow the vehicle, make sure the instructions below are closely followed to prevent damage to the vehicle.

### **! WARNING**

**Do not tow an unbraked vehicle if the combined weight of both vehicles is more than the sum of the gross axle weight ratings (GAWR) of the towing vehicle. Otherwise brake capacity will be inadequate, which could result in personal injury or death.**

## Front Towing Hookup

1. Disconnect the battery ground cables.

### **! CAUTION**

**Failure to remove the axle shafts when towing the vehicle with the rear wheels on the ground could result in damage to the transmission and other parts.**

2. Remove both drive axle shafts. On dual drive axles, if the vehicle is to be lifted and towed, remove only the rearmost drive axle shafts.  
  
On vehicles equipped with an air fairing, remove both the forward and rearmost drive axle shafts if there is insufficient towing clearance.
3. Cover the ends of the hubs with metal plates or plywood cut to fit the axle opening, and drilled to fit the axle shaft studs. This prevents lubricant from leaking out, and will keep contaminants from getting into and damaging the wheel bearings and axle lubricant.

# In an Emergency

---

## CAUTION

Failure to protect the frame rails from the chains could cause damage, leading to eventual frame failure.

4. On dual drive axles, if the vehicle is to be lifted and towed, chain the forward rear-axle assembly to the vehicle frame; use protection to keep the chains from damaging the frame.
5. Remove the bumper extension and chrome bumper, if so equipped. Remove the bumper fairing, if so equipped.
6. On vehicles equipped with an air fairing, adjust the trim tab to the lowest position.

## CAUTION

Do not pass a sling (for example, a rope or chain) from one tow hook to another to fasten for towing (see Fig. 13.2). Known as reeving, this practice is *not* permissible in most industrial applications of towing and hoisting. Reeving can overload the hooks and result in damage to the vehicle.

7. Attach the towing device. Due to the many variables that exist in towing, positioning the lifting and towing device is the sole responsibility of the towing-vehicle operator.
8. On vehicles equipped with an air fairing, measure the distance from the ground to the bumper, or from the ground to a frame bracket.
9. Lift the vehicle, and secure the safety chains. If extra towing clearance is needed, remove the front wheels.

## WARNING

Failure to lower the vehicle could result in the air fairing striking an overhead obstruction, such as a bridge or overpass, and causing vehicle damage or personal injury.

10. On vehicles equipped with an air fairing, repeat the measurement taken in step 8. The difference between the two measurements must not exceed 14 inches (36 cm). If necessary, lower the vehicle.

11. Connect the clearance lights, taillights, and signal lights. Connect any special towing lights required by local regulations.

## WARNING

Failure to chock the tires or connect the tow truck's air brake system before releasing the spring parking brakes could allow the disabled vehicle to suddenly roll. This could cause property damage or personal injury.

12. Chock the disabled vehicle's tires, and connect the towing vehicle's air brake system to the vehicle being towed. Then, release the spring parking brakes and remove the chocks.

## Rear Towing Hookup

### CAUTION

Using a rear towing hookup on a vehicle equipped with a roof fairing could cause damage to the cab structure.

1. Place the front tires straight forward, and secure the steering wheel in this position.
2. Disconnect the battery ground cables.

### CAUTION

Failure to protect the frame rails from the chains could cause damage, leading to eventual frame failure.

3. On dual drive axles, using protection to keep the chains from damaging the vehicle frame, chain the forward-rear drive axle to the frame.
4. Attach the towing device. Due to the many variables that exist in towing, positioning the lifting and towing device is the sole responsibility of the towing-vehicle operator.
5. Lift the vehicle, and secure the safety chains. If extra clearance is needed, remove the bumper extension, if equipped.
6. Connect the clearance lights, taillights, and signal lights. Also connect any special towing lights required by local regulations.

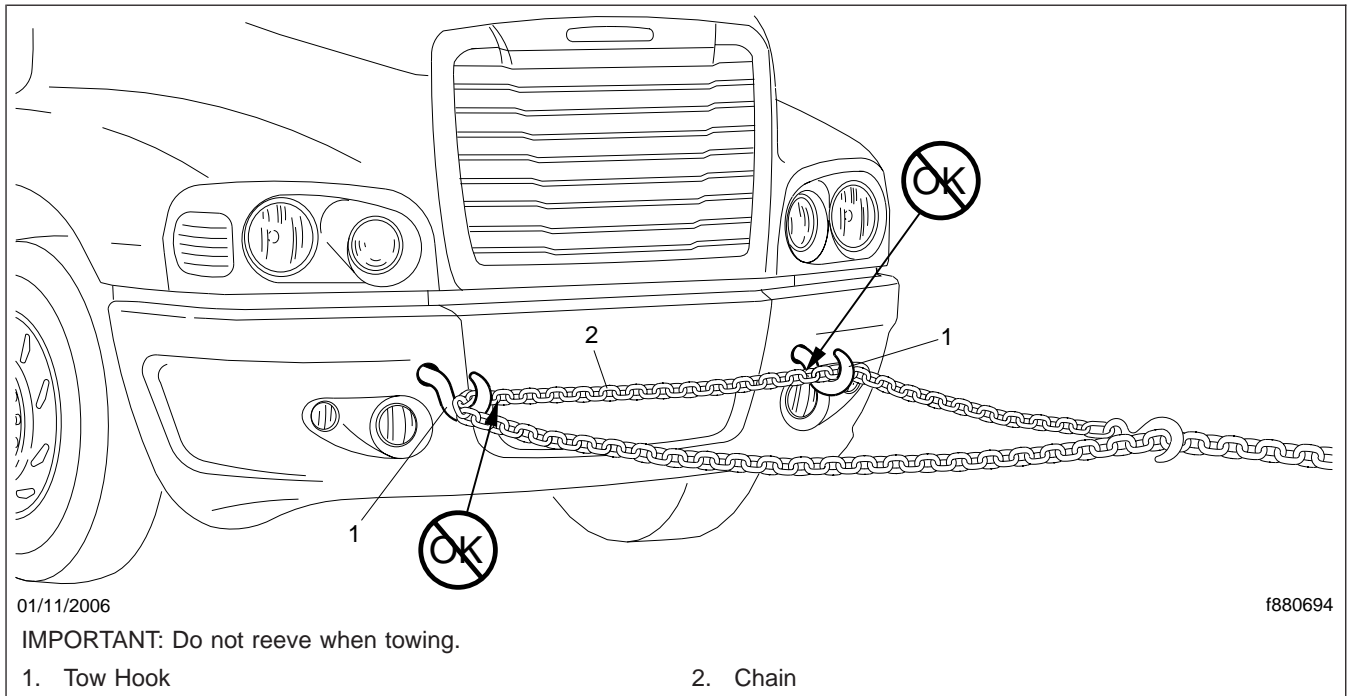


Fig. 13.2, Reeving

## Fire in the Cab

The incidence of fire in heavy- and medium-duty trucks is rare, according to data from the National Highway Traffic Safety Administration. Federal Motor Vehicle Safety Standard #302 limits the flammability of specified materials used inside the cab, but despite this, most materials will burn. The cab of this vehicle contains urethane foam, which is of concern in this respect.

### **WARNING**

**Urethane foam is flammable! Do not allow any flames, sparks, or other heat sources such as cigarettes or light bulbs to contact urethane foam. Urethane foam in contact with such heat sources could cause a serious, rapid fire, which could result in death, severe burns, or gas poisoning, as well as damage to the vehicle.**

## In Case of a Cab Fire

As quickly as possible, bring the vehicle to a safe stop, apply the parking brake, turn off the ignition, and get out of the vehicle.

# Index

---

Subject	Page	Subject	Page
<b>A</b>			
Air Conditioning, Auxiliary (Sleeper Bunk) Heater and Air Conditioner	4.3	Aftertreatment System (ATS) Request/Inhibit Regen Switch	2.6
Air Conditioning	4.2	Air-Suspension Switch, Optional	2.6
Allison Automatic Models	8.18	Allison Automatic- Transmission Controls	2.9
General Information	8.18	Axle Controls	2.4
<b>B</b>			
Back-of-Cab Grab Handles, Steps, and Deck Plate	3.7	Battery-Isolation Switch	2.10
Accessing Back-of-Cab Area	3.7	Clearance Lights/Blink Switch	2.3
Exiting the Back-of-Cab Area	3.8	Cruise Control, Optional	2.7
Baggage Compartment Doors	3.7	Daytime-Running Lights	2.3
Battery Box Cover	3.8	Engine Brake Controls	2.4
Brake System	6.1	Engine-Air Switch, Optional	2.6
Antilock Braking System (ABS)	6.3	Fan Override Switch	2.6
Automatic Slack Adjusters	6.4	Fifth Wheel Air Slide Control Valve Switch	2.5
Brake System Operation	6.2	Flash-to-Pass	2.7
General Information	6.1	Fog Lights Switch	2.3
Trailer ABS Lamp Operation	6.4	Hazard-Warning-Light Switch	2.9
<b>C</b>			
Cab Door Locks and Handles	3.1	Headlight High/Low Beam Control (Signal-Stat)	2.7
Cab Washing and Polishing	12.1	Headlight High/Low Beam Control	2.7
Cab-to-Sleeper Access	3.5	Headlight/Parking Light Switch	2.3
Canadian Motor Vehicle Safety Standard (CMVSS) Labels	1.2	Heater/Air-Conditioner Controls	2.4
Care of Chrome Parts	12.1	Horn	2.9
Care of Fiberglass Parts	12.1	Hot Post, Optional	2.4
Cleaning and Maintaining		Idle-Speed Control, Optional	2.3
Safety Belts	12.3	Ignition Switch	2.1
Cleaning Exterior Lights	12.3	Instrument Panel Dimmer Switch	2.2
Cleaning Exterior Plastic	12.3	Mirror Controls	2.2
Cleaning Lights	12.4	Parking Brake Valve	2.5
Cleaning Mirrors	12.4	Power Locks	2.1
Cleaning the Engine	12.3	Power Windows	2.1
Clutches	7.25	Road Lights Switch	2.3
Clutch Operation	7.25	Suspension Seat Adjustment Controls	2.9
General Information	7.25	Tilt/Telescoping Steering Wheel	2.6
Lubrication	7.26	Trailer Air-Supply Valve	2.5
Cold-Weather Operation, CAT, Cummins, DDE S60, M-B	7.8	Trailer-Brake Hand Control Valve	2.9
Caterpillar	7.8	Transmission Controls	2.9
Cummins	7.9	Turn Signals	2.7
Detroit Diesel S60	7.10	Windshield Wiper/Washer Controls	2.7
Mercedes-Benz	7.10		
Controls	2.1		

Subject	Page	Subject	Page
<b>D</b>			
Dashboard Care	12.1	Mercedes-Benz Engine Operation	7.17
DD15 Heavy-Duty Engine	7.3	Engine Shutdown, CAT, Cummins, DDE S60, M-B	7.19
DDEC VI Driving Tips	7.4	Caterpillar	7.19
Engine Protection	7.3	Cummins	7.20
Defogging and Defrosting Using Fresh Air	4.1	Detroit Diesel S60	7.20
Door Windows	3.3	Mercedes-Benz	7.21
<b>E</b>			
Eaton Fuller AutoShift Automated Models	8.1	Engine Starting, CAT, Cummins, DDE S60, M-B	7.6
General Information, AutoShift	8.1	Caterpillar	7.6
Operation, AutoShift with SmartShift	8.2	Cold-Weather Start Systems	7.8
Eaton UltraShift™ DM	8.4	Cummins and Detroit Diesel S60	7.7
General Information, UltraShift DM	8.4	Mercedes-Benz	7.7
Operation, UltraShift DM	8.5	EPA Emission Control	1.2
Ultrashift Diagnostics	8.9	EPA07 Exhaust Emissions	1.2
Eaton Vorad	2.25	Vehicle Noise Emission Control Label	1.2
Driver Display Unit (DDU)	2.26	EPA07 Aftertreatment System (ATS)	7.1
Failure Display Mode/Fault Codes	2.30	<b>F</b>	
In Case of Accident	2.29	Federal Motor Vehicle Safety Standard (FMVSS) Labels	1.1
Maintenance and Diagnostics	2.29	Fire Extinguisher	13.1
Side Sensor Display, Optional	2.28	Fire in the Cab	13.4
Special Road Situations	2.28	In Case of a Cab Fire	13.4
Emergency Kit, Optional	13.1	Fontaine Fifth Wheels	10.6
Emergency Starting with Jumper Cables	13.1	Fifth Wheel Locking Operation	10.7
Engine Braking System, CAT, Cummins, DDE S60, M-B	7.21	Fifth Wheel Lubrication	10.10
CAT BrakeSaver	7.21	Fifth Wheel Slide Operation	10.9
Constant-Throttle Engine Brake (MBE4000 only)	7.24	General Information	10.6
Exhaust Brake	7.22	Freightliner SmartShift Transmission Shift Control, Optional	8.1
Jacobs Engine Brake	7.23	General Information	8.1
Turbo Brake (MBE4000 only)	7.24	Fresh Air	4.2
Engine Break-In, CAT, Cummins, DDE S60, M-B	7.11	Fuller Deep-Reduction and Range-Shift Models	8.15
Engine Operation, CAT, Cummins, DDE S60, M-B	7.11	General Information	8.15
Caterpillar Engine Operation	7.12	Operation	8.16
Cummins Engine Operation	7.13	Fuller Range-Shift Models	8.11
Detroit Diesel S60 Engine Operation	7.15	General Information	8.11
Engine Protection	7.11	Operation	8.11
		Fuller Splitter and Range-Shift Models	8.13
		General Information	8.13
		Operation	8.13
		Fuller Straight-Shift Models	8.10
		General Information	8.10

# Index

---

Subject	Page
Operation	8.10

## G

Grab Handles and Access Steps	3.1
Entering the Driver's Side (Left-Hand Drive)	3.2
Entering the Driver's Side (Right-Hand Drive)	3.3
Entering the Passenger's Side (Left-Hand Drive)	3.2
Entering the Passenger's Side (Right-Hand Drive)	3.3
Exiting the Driver's Side (Left-Hand Drive)	3.2
Exiting the Driver's Side (Right-Hand Drive)	3.3
Exiting the Passenger's Side (Left-Hand Drive)	3.2
Exiting the Passenger's Side (Right-Hand Drive)	3.3

## H

Hazard Warning Lights	13.1
Heating, Auxiliary (Sleeper Bunk) Heater and Air Conditioner	4.2
Heating	4.2
High-Altitude Operation, CAT, Cummins, DDE S60, M-B	7.21
Caterpillar	7.21
Cummins	7.21
DDE S60, Mercedes-Benz	7.21
Holland Fifth Wheels	10.1
Fifth Wheel Locking Operation	10.2
Fifth Wheel Lubrication	10.6
Fifth Wheel Slide Operation	10.4
General Information	10.1
Hood Tilting	3.8
To Return the Hood	3.8
To Tilt the Hood	3.8
HVAC General Information	4.1

## I

Ignition and Lock Key	3.1
Inside Windows	12.4
Instrumentation Control Unit 3 (ICU3)	2.19
ICU3 Ignition Sequence	2.19
Mode/Reset Switch	2.23

Subject	Page
Instrumentation Control Unit 4 (ICU4)	2.16
Buzzer and Chime	2.16
Ignition Sequence	2.17
Mode/Reset Switch	2.17
Instruments	2.10
Application Air Pressure Gauge, Optional	2.13
Coolant Temperature Gauge	2.10
Engine Oil Pressure Gauge	2.10
Engine Oil Temperature Gauge, Optional	2.11
Forward and Rear Axle Oil Temperature Gauges, Optional	2.13
Fuel Gauge	2.12
Intake-Air Restriction Gauge, Optional	2.13
Primary and Secondary Air Pressure Gauges	2.12
Pyrometer, Optional	2.12
Speedometer/Odometer	2.10
Tachometer/Engine Hours Meter	2.10
Transmission Oil Temperature Gauge, Optional	2.12
Voltmeter	2.11

## L

Leather Upholstery Cleaning	12.3
-----------------------------	------

## M

Meritor Drive Axles with Main Differential Lock	9.1
Meritor Interaxle Differential Lockout Operation	9.2
Meritor Main Differential Lock Operation	9.1
Meritor Tandem Drive Axles with Interaxle Differential	9.1

## N

NGI Instrument Cluster	2.23
Instruments	2.23
Lightbar	2.23
Message Center	2.23
Mode and Set Buttons	2.23

Subject	Page	Subject	Page
<b>P</b>		<b>U</b>	
Power Distribution Module and Power Distribution Box	3.4	Underbody	12.3
Pretrip and Post-Trip Inspection Checklists	11.1	<b>V</b>	
Pretrip and Post-Trip Maintenance Procedures	11.3	Vehicle Specification Decal	1.1
Daily Pretrip Inspection and Maintenance	11.3	Velour Upholstery Cleaning	12.2
Monthly Post-Trip Inspection and Maintenance	11.15	Chewing Gum or Wax	12.3
Weekly Post-Trip Inspection and Maintenance	11.13	Grease and Oil-Based Stains	12.2
<b>R</b>		Mildew	12.3
Reflective Material	12.3	Sugar and Water-Based Stains	12.2
Roll Stability Control	2.30	Vinyl Upholstery Cleaning	12.1
<b>S</b>		Ball Point Ink	12.2
Seat Belts and Tether Belts	5.5	Chewing Gum	12.2
General Information	5.5	Miscellaneous	12.2
Seat Belt Operation	5.5	Nail Polish and Nail Polish Remover	12.2
Seats	5.1	Ordinary Dirt	12.1
Bostrom Talladega™ 915 Seat	5.2	Paint, Shoe Heel Marks	12.2
EzyRider® Seat	5.2	Shoe Polish	12.2
General Information	5.1	Sulfide Stains	12.2
National 2000 Series Seat	5.3	Tars, Asphalts, and Creosote	12.2
National Nonsuspended Seat	5.4	<b>W</b>	
Two-Passenger Bench Seat	5.5	Warning and Indicator Lights	2.13
Sleeper Bunk Latches	3.6	Engine Protection	2.15
Sleeper Compartment Bunk Restraints	5.7	Woodtone Trim	12.4
Bunk Restraint Adjustment	5.7		
Bunk Restraint Operation	5.7		
General Information	5.7		
Sleeper Compartment Exit Door	3.6		
Sleeper Compartment Vents	3.3		
Steering System	6.1		
General Information	6.1		
Power Steering System	6.1		
<b>T</b>			
Tire and Rim Labels	1.2		
Towing	13.2		
Front Towing Hookup	13.2		
Rear Towing Hookup	13.3		