

## Introduction

This manual provides information needed to operate and understand the vehicle and its components. More detailed information is contained in the *Owner's Warranty Information for North America* booklet, and in the vehicle's workshop and maintenance manuals.

Custom-built Sterling vehicles are equipped with various chassis and cab components. Not all of the information contained in this manual applies to every vehicle. For details about components in your vehicle, refer to the chassis specification pages included in all new vehicles and to the vehicle specification decal located inside the vehicle.

For your reference, keep this manual in the vehicle at all times.

**IMPORTANT:** Descriptions and specifications in this manual were in effect at the time of printing. Sterling Truck Corporation reserves the right to discontinue models and to change specifications or design at any time without notice and without incurring obligation. Descriptions and specifications contained in this publication provide no warranty, expressed or implied, and are subject to revisions and editions without notice.

## Environmental Concerns and Recommendations

Whenever you see instructions in this manual to discard materials, you should first attempt to reclaim and recycle them. To preserve our environment, follow appropriate environmental rules and regulations when disposing of materials.

## Event Data Recorder

This vehicle is equipped with one or more devices that record specific vehicle data. The type and amount of data recorded varies depending on how the vehicle is equipped (such as the brand of engine, if an air bag is installed, or if the vehicle features a collision avoidance system, etc.).

## Customer Assistance Center

Having trouble finding service? Call the Customer Assistance Center at 1-800-785-4357 or 1-800-STL-HELP. Call night or day, weekdays or weekends, for dealer referral, vehicle information, breakdown coordi-

nation, or Fleetpack assistance. Our people are knowledgeable, professional, and committed to following through to help you keep your truck moving.

## Reporting Safety Defects

If you believe that your vehicle has a defect which could cause a crash or could cause injury or death, you should immediately inform the National Highway Traffic Safety Administration (NHTSA) in addition to notifying Sterling Truck Corporation.

If the NHTSA receives similar complaints, it may open an investigation and if it finds that a safety defect exists in a group of vehicles, it may order a recall and remedy campaign. However, NHTSA cannot become involved in individual problems between you, your dealer, or Sterling Truck Corporation.

To contact NHTSA, you may call the Vehicle Safety Hotline toll-free at 1-888-327-4236 (TTY: 1-800-424-9153); go to [www.safercar.gov](http://www.safercar.gov); or write to: Administrator, NHTSA, 1200 New Jersey Avenue, SE, Washington, DC 20590. You can also obtain other information about motor vehicle safety from [www.safercar.gov](http://www.safercar.gov).

Canadian customers who wish to report a safety-related defect to Transport Canada, Defect Investigations and Recalls, may telephone the toll-free hotline 1-800-333-0510, or contact Transport Canada by mail at: Transport Canada, ASFAD, Place de Ville Tower C, 330 Sparks Street, Ottawa, Ontario, Canada K1A 0N5.

For additional road safety information, please visit the Road Safety website at: [www.tc.gc.ca/roadsafety/menu.htm](http://www.tc.gc.ca/roadsafety/menu.htm).

# Foreword

---

© 2000–2009 Daimler Trucks North America LLC. All rights reserved. Daimler Trucks North America LLC is a Daimler company.

No part of this publication, in whole or part, may be translated, stored in a retrieval system, or transmitted in any form by any means, electronic, mechanical, photocopying, recording, or otherwise, without the prior written permission of Daimler Trucks North America LLC. For additional information, please contact Daimler Trucks North America LLC, Service Systems and Documentation, P.O. Box 3849, Portland OR 97208–3849 U.S.A. or refer to [www.Daimler-TrucksNorthAmerica.com](http://www.Daimler-TrucksNorthAmerica.com) and [www.SterlingTrucks.com](http://www.SterlingTrucks.com).

# Contents

---

Chapter		Page
	Introduction, Environmental Concerns and Recommendations, Event Data Recorder, Customer Assistance Center, Reporting Safety Defects .....	Foreword
1	Vehicle Identification .....	1.1
2	Instruments and Controls Identification .....	2.1
3	Vehicle Access and Features .....	3.1
4	Heater and Air Conditioner .....	4.1
5	Seats and Seat Belts .....	5.1
6	Steering and Brake Systems .....	6.1
7	Engines and Clutches .....	7.1
8	Transmissions .....	8.1
9	Rear Axles .....	9.1
10	Fifth Wheels .....	10.1
11	Pretrip and Post-Trip Inspections and Maintenance .....	11.1
12	Cab Appearance .....	12.1
13	In an Emergency .....	13.1
	Index .....	I.1

# 1

## Vehicle Identification

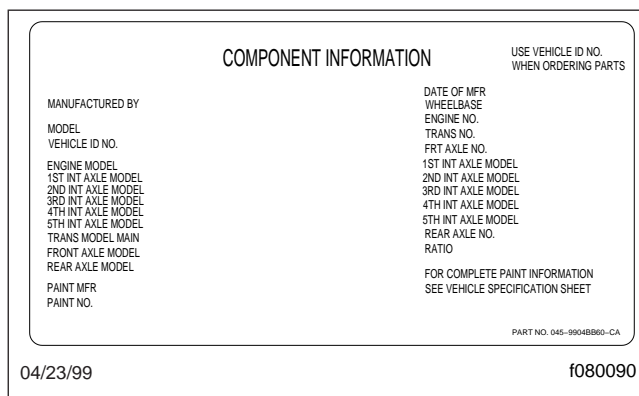
---

Vehicle Specification Decal .....	1.1
Federal Motor Vehicle Safety Standard (FMVSS) Labels .....	1.1
Canadian Motor Vehicle Safety Standard (CMVSS) Labels .....	1.2
Tire and Rim Labels .....	1.2
EPA Emission Control .....	1.2

# Vehicle Identification

## Vehicle Specification Decal

The vehicle specification decal lists the vehicle model, identification number, and major component models. It also recaps the major assemblies and installations shown on the chassis specification sheet. The specification decal is inside the rear cover of the *Owner's Warranty Information for North America* booklet. An illustration of the decal is shown in **Fig. 1.1**.



**Fig. 1.1, Vehicle Specification Decal, Canadian-Built Vehicle Shown**

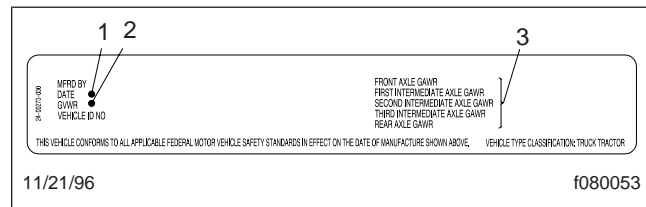
NOTE: Labels shown in this chapter are examples only. Actual specifications may vary from vehicle to vehicle.

## Federal Motor Vehicle Safety Standard (FMVSS) Labels

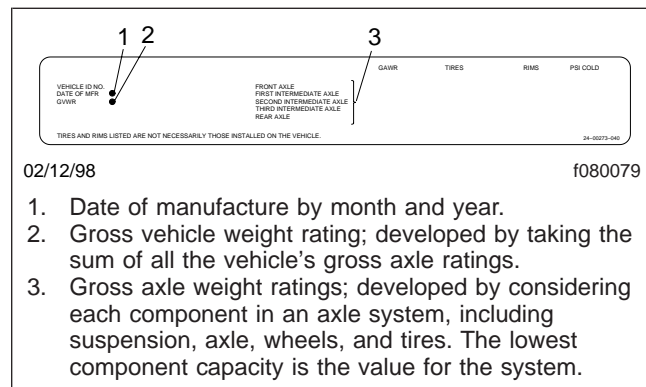
NOTE: Due to the variety of FMVSS certification requirements, not all of the labels shown will apply to your vehicle.

Tractors with or without fifth wheels purchased in the U.S. are certified by means of a certification label (**Fig. 1.2**) and the tire and rim labels (**Fig. 1.3**). These labels are attached to the left side rear door jamb, as shown in **Fig. 1.4**.

If purchased for service in the U.S., trucks built without a cargo body have a certification label (**Fig. 1.5**) attached to the left side rear door jamb. See **Fig. 1.4**. In addition, after completion of the vehicle, a certification label similar to that shown in **Fig. 1.2** must be attached by the final-stage manufacturer. This label will be located on the left side rear door jamb and certifies that the vehicle conforms to all applicable

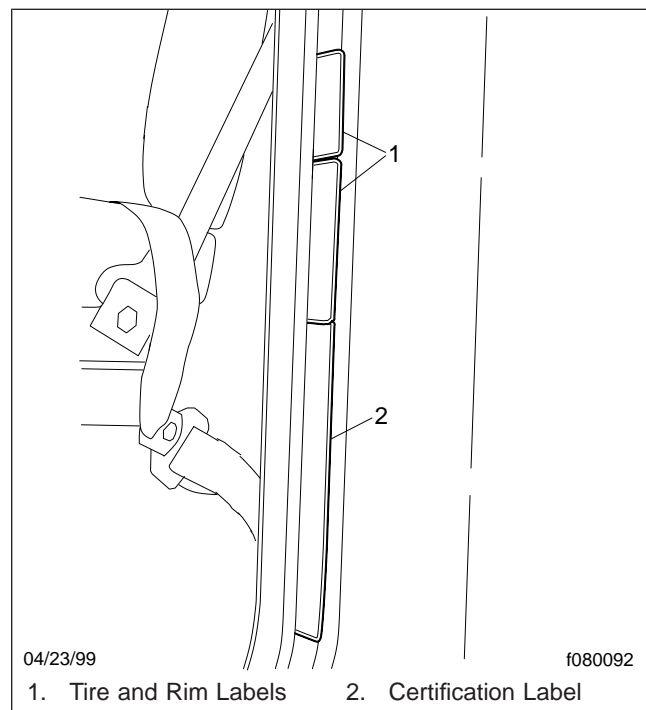


**Fig. 1.2, Certification Label, U.S.**



1. Date of manufacture by month and year.
2. Gross vehicle weight rating; developed by taking the sum of all the vehicle's gross axle ratings.
3. Gross axle weight ratings; developed by considering each component in an axle system, including suspension, axle, wheels, and tires. The lowest component capacity is the value for the system.







**Fig. 1.3, Tire and Rim Label**



**Fig. 1.4, Labels Location**



# Vehicle Identification

EXHAUST AFTERTREATMENT SYSTEM INFORMATION					
INDICATOR LAMP(S)	 (Solid) Level 1	 (Flashing) Level 2	 (Flashing) CHECK Level 3	 (Flashing) CHECK STOP Level 4	 WARNING 
Indicator Lamp Message(s)	Filter Regeneration Recommended	Filter Regeneration Necessary	Parked Regeneration Required – Engine Derate	Parked Regeneration Required – Engine Shut Down	HEST (High Exhaust System Temperature)
Diesel Particulate Filter Condition	Filter is reaching capacity.	Filter is now reaching maximum capacity.	Filter has reached maximum capacity.	Filter has exceeded maximum capacity.	<b>Flashing</b> A regeneration is in progress.
Required Action	Bring vehicle to highway speeds to allow for an Automatic Regeneration or perform a Parked Regeneration.	To avoid engine derate bring vehicle to highway speeds to allow for an Automatic Regeneration or perform a Parked Regeneration as soon as possible.	Vehicle must be parked and a Parked Regeneration must be performed – engine will begin derate.	Vehicle must be parked and a Parked Regeneration or Service Regeneration must be performed. Check engine operator's manual for details –engine will shut down.	<b>Solid</b> Exhaust Components and exhaust gas are operating at high temperature. When stationary, keep away from people and flammable materials, vapors, or structures.
For a driver performed Parked Regeneration, vehicle must be equipped with a dash mounted Regeneration Switch.					
<b>See Engine Operator's Manual for complete Regeneration Instructions.</b>					
<small>24-01583-0008</small>					

02/20/2009

f080147

Fig. 1.8, Sunvisor Warning Label

# 2

## Instruments and Controls Identification

---

Instrument and Control Panel .....	2.1
Warning and Indicator Lights .....	2.10
Instruments .....	2.13
Instrumentation Control Unit 4 (ICU4) .....	2.16
Instrumentation Control Unit 3 (ICU3 and ICU3 '07) .....	2.21
NGI Instrument Cluster, Optional .....	2.23



# Instruments and Controls Identification

## Instrument and Control Panel

**Figure 2.1** represents a typical instrument and control panel equipped with all of the standard and many of the optional instruments and controls.

### Ignition Switch and Key

The ignition switch has four positions: OFF, START, ON, and accessory (ACC). See **Fig. 2.2**. The ignition key can be inserted and removed only in the OFF position. The ignition key also locks and unlocks the cab doors from the outside.

With the ignition switch in the OFF position, whether the ignition key is inserted or not, the low-beam headlights, hazard warning lights, marker lights, clearance lights, dome lights, parking lights, and the brake lights will operate.

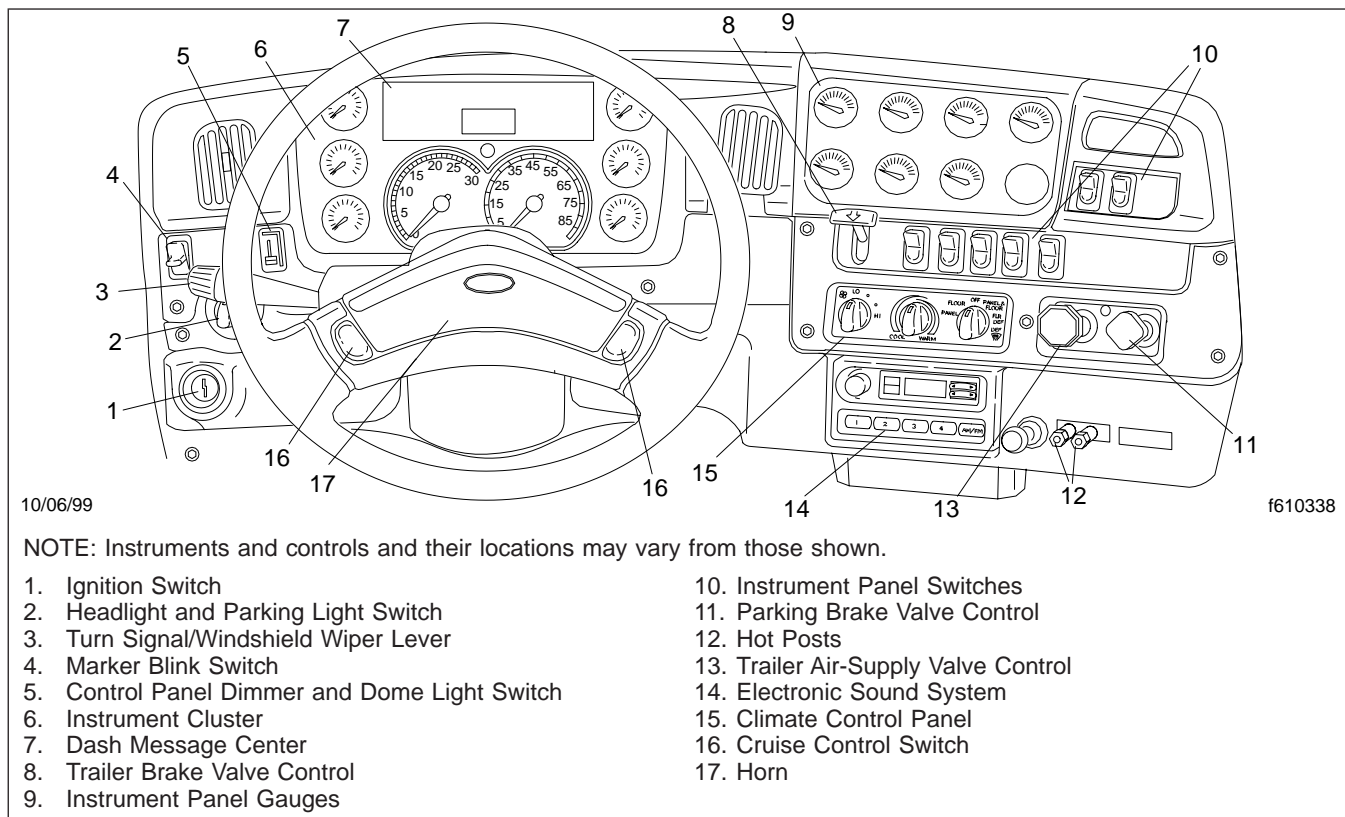
To start the engine, turn the ignition key 90 degrees clockwise to the START position. After the engine has started, release the key and it will return to the on position.

In the ON position, the key is turned 45 degrees clockwise. With the ignition switch in the ON position, all the electrical systems are operable. The warning lights and buzzer indicating low air pressure and low oil pressure will operate until the engine is started and the minimum pressures are built up.

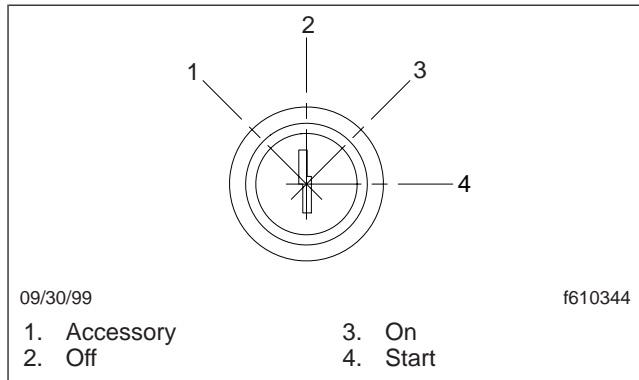
In the ACC position, the key is turned 45 degrees counterclockwise. With the ignition switch in the accessory position, the radio, windshield wipers, heated mirrors, power mirrors, and power windows are operable.

### Power Window Switch, Optional

The power window switch is located on the driver's door and controls the passenger window if there is a manual window regulator for the driver's door. If there are two power window switches on the driver's door, one switch controls the driver's window and one switch controls the passenger's window. See **Fig. 2.3**. The passenger's door also has a power



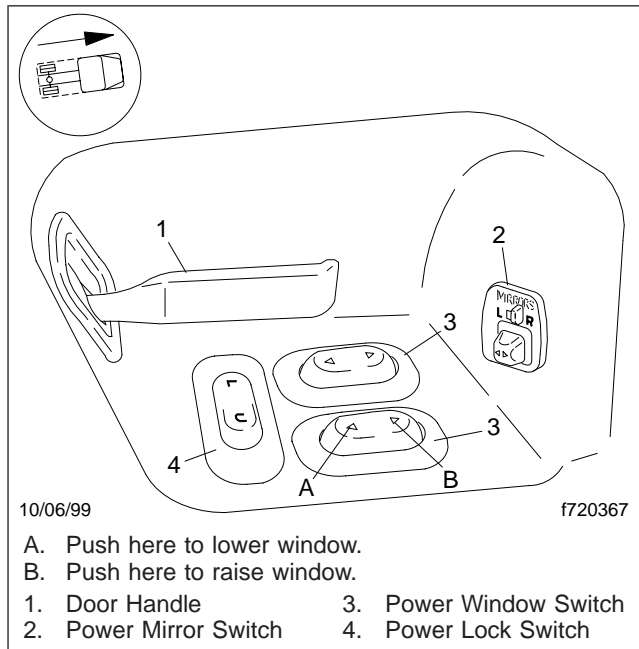
**Fig. 2.1, Instrument and Control Panel Layout**



**Fig. 2.2, Ignition Switch Positions**

window switch if both doors are controlled electrically.

Push the dimpled end of the power window switch to lower the window; push the raised end of the switch to raise the window.



**Fig. 2.3, Power Lock, Window, and Mirror Switches**

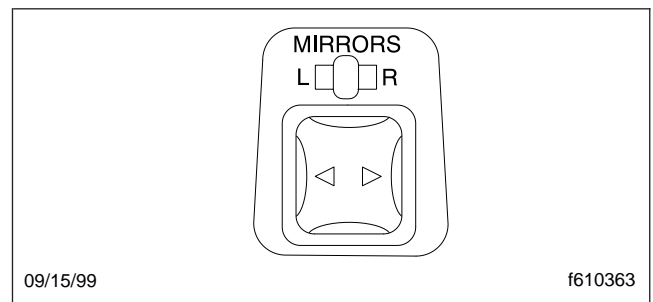
## Power Lock Switch, Optional

The power lock switch (Fig. 2.3) is located below the door handle on the driver's side and the passenger's side of the cab. Press the **L** to lock the doors. Press the **U** to unlock the doors.

## Mirror Controls

### Power Mirror Switch, Optional

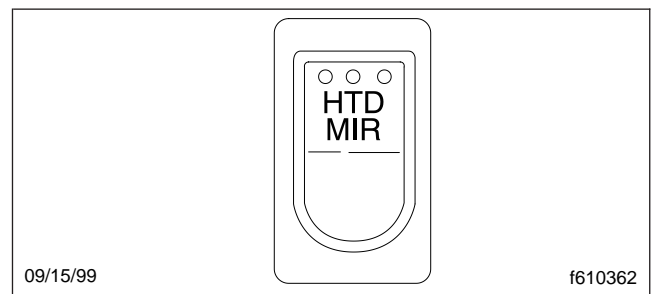
The position of the door-mounted mirrors is controlled by the power mirror switch (Fig. 2.4) located near the door handle on the driver's side of the cab. Move the lever toward the **L** to control the left mirror, and toward the **R** to control the right mirror. Move the button to the left or right to control the position of the mirror.



**Fig. 2.4, Power Mirror Switch**

### Heated Mirror Switch, Optional

One or both door-mounted mirrors can be heated to keep them defrosted. Press the upper end of the heated mirror switch (Fig. 2.5) to heat the mirrors. When the heated mirror switch is pressed, the **MIR HEAT** indicator on the dash message center comes on.



**Fig. 2.5, Heated Mirror Switch**

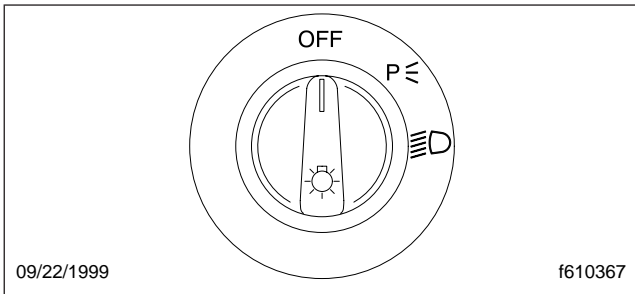
### Lighted Mirrors, Optional

The lights on the door-mounted mirrors act as marker lights. Push the paddle on the marker blink (MARK BLNK) switch (Fig. 2.7) down to turn on the mirror lights.

# Instruments and Controls Identification

## Headlight and Parking Light Switch

The headlight and parking light switch (**Fig. 2.6**) is located above the ignition switch. Turn the switch 45 degrees clockwise to turn on the parking lights. Turn the switch 90 degrees clockwise to turn on the headlights.



**Fig. 2.6, Headlight and Parking Light Switch**

## Daytime Running Lights, Optional



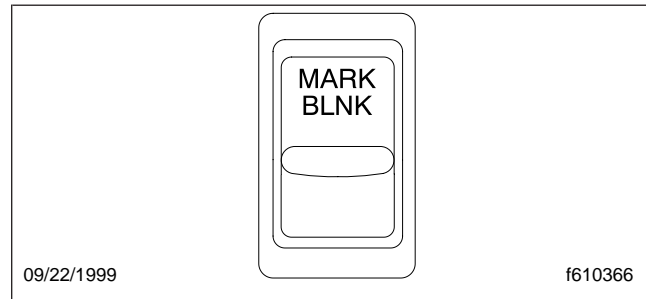
**When the daytime running lights are on, only the headlights are illuminated at a reduced intensity. The marker lights, taillights, and trailer lights are not illuminated. Turn the headlights ON at dusk. Using the daytime running lights at night could cause an accident resulting in personal injury or property damage.**

The daytime running lights are turned on when the engine is started, the parking brake is released, and the headlight switch is in the OFF position. The daytime running lights illuminate the headlights at a reduced intensity during daytime driving. These lights are not to be used in place of the headlights during reduced visibility or nighttime driving conditions.

For vehicles built to operate in Canada, daytime running lights are required.

## Marker Blink Switch

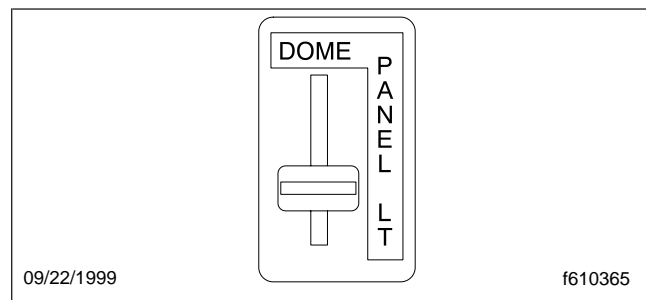
The marker blink (MARK BLNK) switch (**Fig. 2.7**) is a paddle switch located above and to the left of the headlight and parking light switch. Push the paddle down to turn on the marker lights. Push the paddle up to blink the marker lights. When the paddle is in the center position, the marker lights are off.



**Fig. 2.7, Marker Blink Switch**

## Instrument and Control Panel Dimmer Switch

The instrument and control panel dimmer switch (**Fig. 2.8**) is located above and to the right of the headlight and parking light switch. The instrument and control panel lights can be brightened by moving the lever up, or dimmed by moving the lever down. The dome light can be turned on by moving the switch all the way up.



**Fig. 2.8, Instrument and Control Panel Dimmer Switch**

## Turn Signal Lever, United Technologies

### Turn Signals

The turn signal lever (**Fig. 2.9**) is located on the left side of the steering column. Push the lever up to turn on the right-turn signal. Pull the lever down to turn on the left-turn signal. The turn signal lever will return to the neutral position after the turn has been completed.

### High-Beam Headlights

Push the turn signal lever away from you to change the headlights from low beam to high beam.

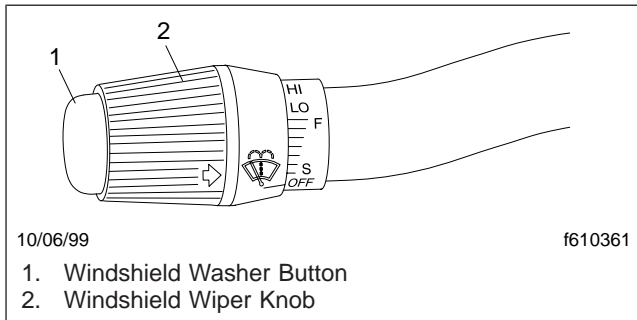


Fig. 2.9, Turn Signal Lever, United Technologies

## Flash to Pass

Pull the turn signal lever toward you and release the lever to momentarily flash the high-beam headlights when the headlights are off.

## Windshield Wipers



**Do not move the wiper arms manually. Wiper motor damage will occur if the arms are moved.**

To turn on the windshield wipers, turn the knob on the end of the turn signal lever. There are seven intermittent wiper speeds from slow to fast, a low speed, and a high speed. See Fig. 2.9.

## Windshield Washer

To turn on the windshield washer, push in the button at the end of the turn signal lever. Windshield washer fluid will continue to spray as long as the button is pushed in. See Fig. 2.9.

## Hazard Warning Lights

Push the hazard warning lights switch (Fig. 2.10) on top of the steering column to turn on the hazard warning lights. Push the switch again to turn off the hazard warning lights.

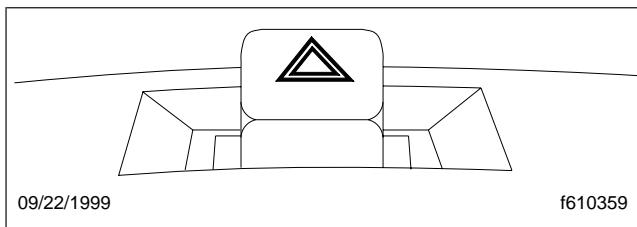


Fig. 2.10, Hazard Warning Lights Switch

## Turn Signal Lever, Signal-Stat Turn Signals

The turn signal lever (Fig. 2.11) is located on the left side of the steering column. Push the lever up to turn on the right-turn signal. Pull the lever down to turn on the left-turn signal. Return the turn signal lever to the neutral position after the turn has been completed.

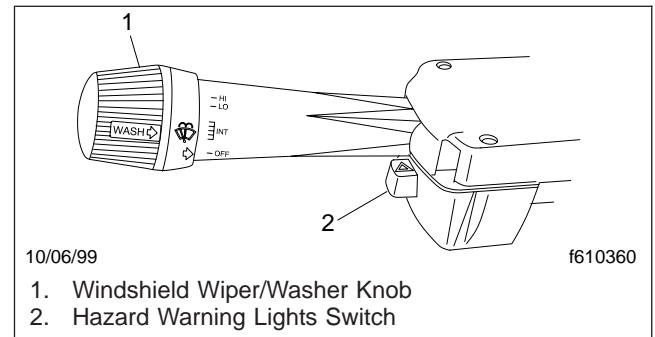


Fig. 2.11, Turn Signal Lever, Signal-Stat

## High-Beam Headlights

Pull the turn signal lever toward you to change the headlights from low beam to high beam.

## Flash to Pass

Pull the turn signal lever toward you and release the lever to momentarily flash the high-beam headlights when the headlights are off.

## Windshield Wipers



**Do not move the wiper arms manually. Wiper motor damage will occur if the arms are moved.**

To turn the windshield wipers on, turn the knob on the end of the turn signal lever. There are five intermittent wiper speeds, a low speed, and a high speed. See Fig. 2.11.

## Windshield Washer

To turn the windshield washer on, push in the button at the end of the turn signal lever. Windshield washer fluid will continue to spray as long as the knob is pushed in. See Fig. 2.11.

# Instruments and Controls Identification

## Tilt, or Tilt and Telescoping Steering Wheel, Optional

### **WARNING**

Make sure that the steering column is locked before driving the vehicle. Never tilt or telescope the steering wheel while driving the vehicle. Doing so could cause loss of vehicle control, personal injury, and property damage.

To tilt the steering wheel, push down on the lever (Fig. 2.12) below the steering wheel, and tilt the column to the desired position. Release the lever to lock the steering wheel in place.

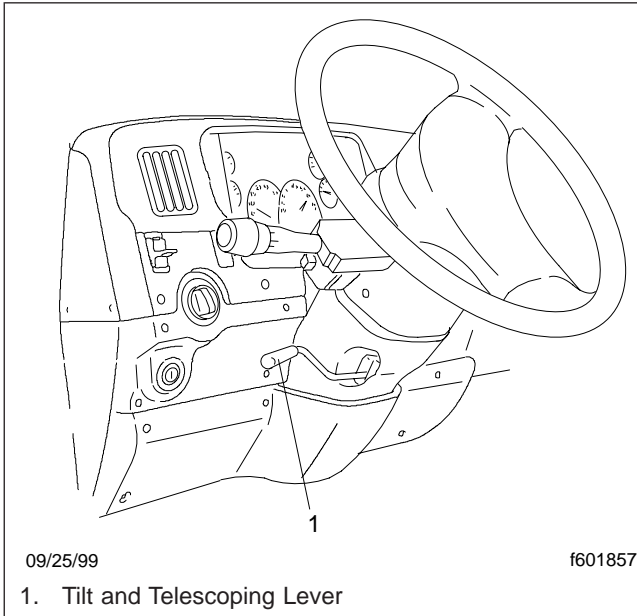


Fig. 2.12, Tilt, or Tilt and Telescoping Steering Wheel

To telescope the steering wheel, pull the lever up and pull the steering wheel closer to you or push the steering wheel farther away. Release the lever to lock the steering wheel in place.

## Horn

Your vehicle is equipped with an electric horn and may have an optional air horn.

To use the electric horn, press the center of the steering wheel. To use the air horn, pull the cable located on the ceiling above the driver's seat.

## Trailer-Brake Hand-Control-Valve Lever

The trailer-brake hand-control-valve lever (Fig. 2.13) is used to apply the trailer brakes without applying the truck or tractor brakes, and is mounted on the instrument and control panel. Pull the lever down to apply the brakes. When the lever is released, the lever will return to the upper position.

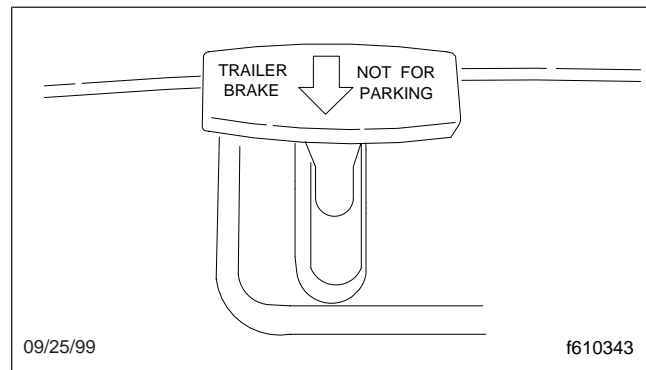


Fig. 2.13, Trailer-Brake Hand-Control-Valve Lever

## Heater and Air-Conditioner Controls

Refer to Chapter 4 for detailed operating instructions of the heater and air conditioner.

## Parking-Brake-Control Valve

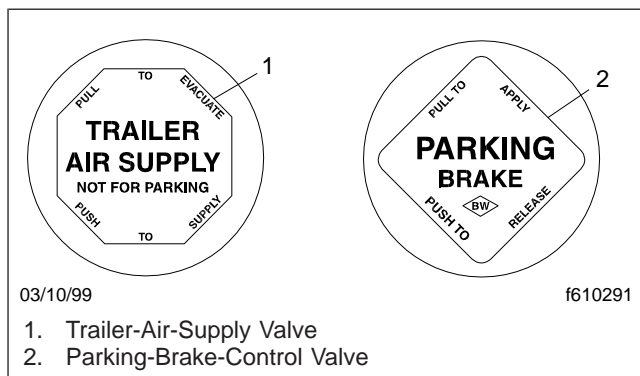
The yellow diamond-shaped knob (Fig. 2.14) operates the parking-brake-control valve. Pulling the knob out applies both the tractor and the trailer spring brakes. Pushing the knob in releases the tractor spring brakes. Before the spring brakes can be released, the air pressure in either air brake system must be at least 65 psi (448 kPa).

Refer to Chapter 6 under the heading "Air Brake System" for instructions regarding the use of the parking-brake-control valve.

## Trailer-Air-Supply Valve

The red octagonal-shaped knob (Fig. 2.14) operates the trailer-air-supply valve. After the vehicle is connected to a trailer, and the air hoses are connected, and the pressure in the air system is at least 65 psi (448 kPa), the trailer-air-supply valve can be pushed in (and should stay in) to charge the trailer-air-supply system and release the trailer spring brakes. Before disconnecting a trailer, or when operating a vehicle

# Instruments and Controls Identification



**Fig. 2.14, Brake Valve Knobs**

without a trailer, the trailer-air-supply valve must be pulled out.

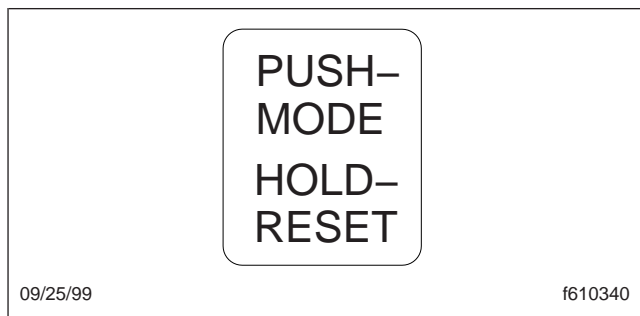
Refer to [Chapter 6](#) under the heading "Air Brake System" for instructions regarding the use of the trailer-air-supply valve.

## Hot Posts

Hot posts ([Fig. 2.1](#)) are provided as a source of power within the cab to operate 12-volt electrical accessories. A power and ground jack are included in the hot post.

## Mode/Reset Switch, Optional

The mode/reset switch ([Fig. 2.15](#)) is located on the right side of the instrument cluster. The mode/reset switch is used to scroll through the displays on the message display screen, and to reset the trip distance and trip hours values to zero. When the mode/reset switch is pressed for one second or less, the switch acts as a mode switch. When the switch is pressed for more than one second, the switch acts as a reset switch.



**Fig. 2.15, Mode/Reset Switch**

To reset the value of the selected display to zero, press the mode/reset switch for one second or longer. To toggle between MI (miles) or KM (kilometers), press the mode/reset switch while in the SELECT screen.

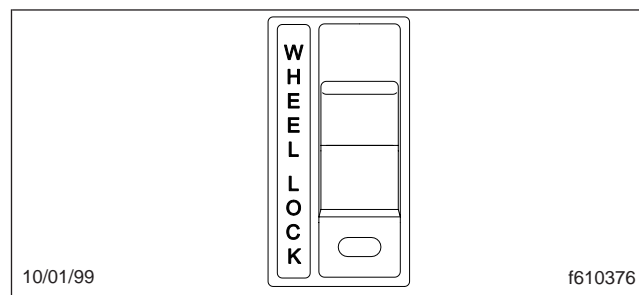
When the odometer reading is displayed and the parking brake is released:

- Press the mode/reset switch once and the trip distance will display.
- Press the mode/reset switch a second time and the trip hours (engine hours) will display.
- Press the mode/reset switch a third time and the SELECT screen and the current units, MI or KM, will display.
- Press the mode/reset switch a fourth time to return to the odometer reading.

## Axle Controls

### Wheel Lock Switch, Optional

The wheel lock switch locks together the wheels on the same axle. Push the wheel lock switch ([Fig. 2.16](#)) up to engage the wheel lock. Move the switch to the center position to disengage the wheel lock. Refer to [Chapter 9](#) for complete operating instructions.



**Fig. 2.16, Wheel Lock Switch**

### Axle Lock Switch, Optional

The axle lock switch is installed on vehicles with tandem rear drive axles. It locks the rear drive axles together. Push the axle lock switch ([Fig. 2.17](#)) up to engage the axle lock. Move the switch to the center position to disengage the axle lock.

# Instruments and Controls Identification

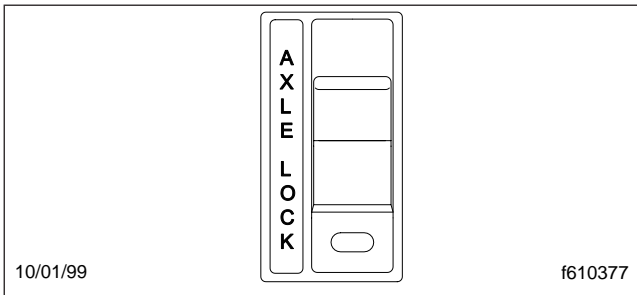


Fig. 2.17, Axle Lock Switch

## All-Wheel-Drive Switches, Optional

All-wheel-drive (AWD) allows the driver to direct driveline power to all four axles, front and rear. Two switches are used to control AWD: an AWD operation switch used to activate all-wheel-drive, and an AWD range switch used to select the high or low range.

The AWD operation switch is a two-position rocker switch with a light-emitting diode (LED) that illuminates when AWD is engaged. The legend LOCKED is underneath the LED on the upper half of the switch. On the lower half is the legend AWD. See Fig. 2.18. When the panel lights are on, the AWD legend is backlit in green.

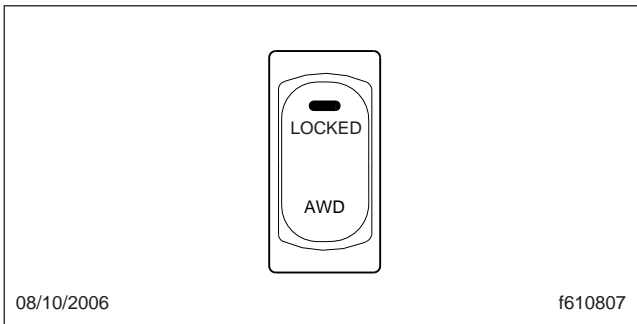


Fig. 2.18, AWD Operation Switch

To engage AWD, press the upper half of the rocker switch. The LED illuminates to indicate that AWD is engaged. To turn off AWD, press the lower half of the switch. The LED goes out to indicate the AWD is no longer engaged.

When AWD is engaged, the LOCKED legend is backlit in red. In addition, a red indicator with the legend FR AXLE ENGAGE displays on the dash message center.

## CAUTION

To prevent damage to the transfer case and the driveline, stop the vehicle and apply the parking brake before using the range switch.

The AWD range switch is used under similar conditions to those of the axle shift switch on a two-speed rear axle. Use the high range when driving at normal speeds under off-road conditions, or on non-paved surfaces. Use the low range when extra traction is needed at low speeds; for example, under conditions of mud, snow, or ice. This switch should be used only when AWD has been engaged.

In most cases, the AWD range switch is a two-position rocker switch with the legends LO RANGE at the upper end and HIGH RANGE at the lower end. On vehicles with a power takeoff unit (PTO), the three-position switch has a neutral (N-TRL) position in the middle. See Fig. 2.19.

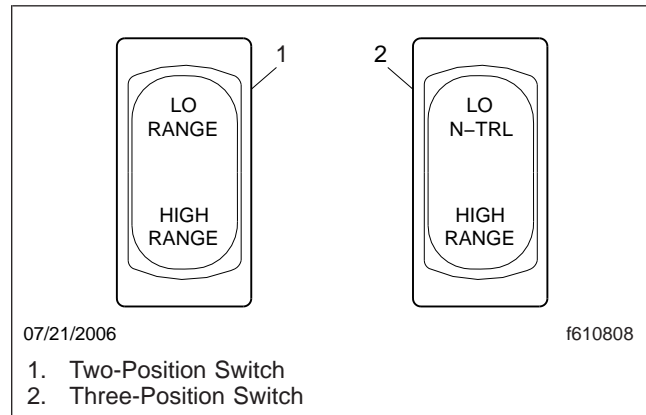


Fig. 2.19, AWD Range Switches

On vehicles without a PTO, high range is considered standard operation. To activate the low range, press the upper half of the switch. When the low range is activated, the LO RANGE legend is backlit in red. In addition, a red indicator with the legend T-CASE LO RANGE displays on the dash message center. To switch back to HIGH RANGE, press the lower half of the switch.

**IMPORTANT:** Always use the N-TRL switch position when operating the PTO.

On vehicles with a PTO, neutral is considered standard operation (switch in the middle position). An

# Instruments and Controls Identification

amber indicator with the legend T-CASE NEUTRL displays on the dash message center.

To activate the high range, press the lower half of the switch. No indicator displays on the dash message center with the high range activated. Press the upper half to return to N-TRL.

To activate the low range, press the upper half of the switch. A red indicator with the legend T-CASE LO RANGE displays on the dash message center. On the switch, the LO N-TRL legend is backlit in red. Press the lower half to return to N-TRL, and then press the lower half again to select HIGH RANGE.

## Traction in Mud or Snow Switch, Optional

If the vehicle is equipped with Automatic Traction Control, the traction in mud or snow (TRAC MUD/SNOW) switch (Fig. 2.20) is used to provide increased traction on soft surfaces such as snow, mud, or gravel by slightly increasing the permissible wheel spin.

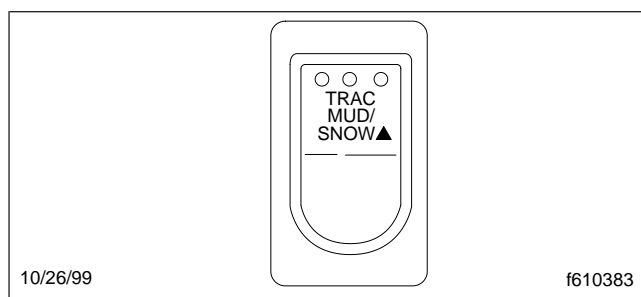


Fig. 2.20, Traction in Mud or Snow Switch

## Engine Brake Controls

### Exhaust Brake Switch, Optional

The exhaust brake restricts the flow of exhaust gases, which slows the engine. Push the exhaust brake switch (Fig. 2.21) up to engage the exhaust brake. Move the switch to the center position to disengage the exhaust brake. Refer to Chapter 7 under the heading "Exhaust Braking System, Optional" for additional information.

### Engine Brake Switch, Optional

The three-position engine brake switch is available only on Mercedes-Benz MBE900 engines. Press the upper half of the engine brake switch to apply both

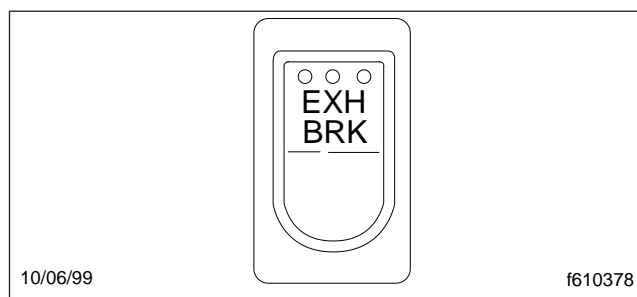


Fig. 2.21, Exhaust Brake Switch

the engine brake and exhaust brake. When the switch is in the center position, only the exhaust brake is applied. When the lower half of the switch is pressed, the switch is off.

## Aftertreatment System (ATS) Request/Inhibit Regen Switch

A parked regen of the ATS can be initiated with the request/inhibit regen switch. See Fig. 2.22. It may also be used to inhibit the vehicle from performing an automatic regen.

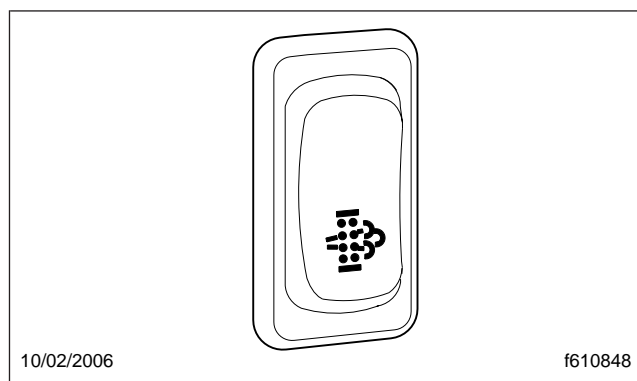


Fig. 2.22, Request/Inhibit Regen Switch

The style and function of switch will vary with the engine make and model. See the engine operation manual for operation details.

## ABS Diagnostic Switch, Optional

The ABS diagnostic switch (Fig. 2.23) is a momentary switch that turns on the blink code diagnostic capabilities. For information on troubleshooting with blink code diagnostics, see Group 42 in the Acterra® Workshop Manual.



# Instruments and Controls Identification

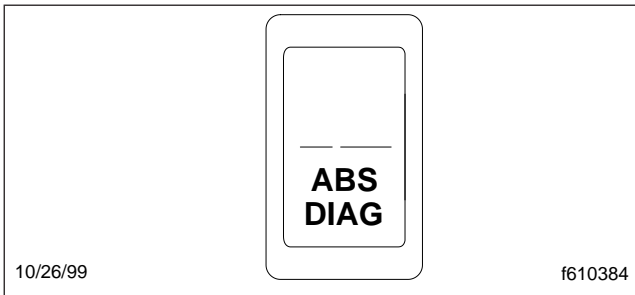


Fig. 2.23, ABS Diagnostic Switch

## Cruise Control

To turn on the cruise control, press the ON switch located on the steering wheel. See Fig. 2.24.

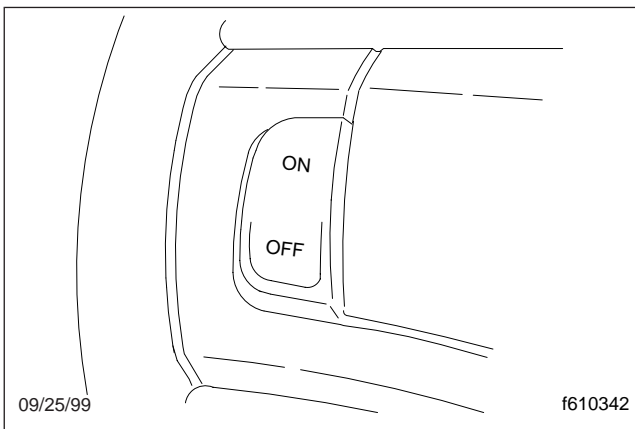


Fig. 2.24, Cruise Control On/Off Switch

**To Set a Speed**—press the set/coast (SET/CST) switch located on the steering wheel, after you have reached the desired speed. See Fig. 2.25. The vehicle will travel at the set speed until the brake pedal or clutch pedal is depressed, or until the cruise control OFF switch is pressed.

The speed control may not operate until a minimum vehicle speed is reached. For more information, refer to your diesel engine operation and maintenance manual.

When driving up a steep hill, the speed control may not be able to maintain the preset speed in the transmission gear position selected. To maintain a preset speed in this situation, downshift the transmission to a lower gear.

**To Set a Higher Set Speed**—choose one of three ways to set a higher set speed.

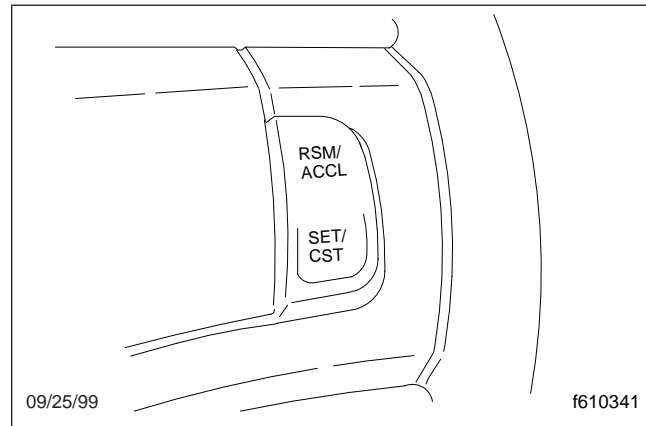


Fig. 2.25, Speed Control Switch

- Press and hold the resume/accelerate (RSM/ACCL) switch (Fig. 2.25) located on the steering wheel until the higher set speed is reached. Then release the switch.
- Press and release the resume/accelerate switch. Each press of the switch will increase the set speed by 1 mph (1.6 km/h).
- Press and release the resume/accelerate switch and depress the accelerator pedal until the desired speed is reached. Then press the set/coast (SET/CST) switch.

You can accelerate with the throttle pedal at any time during cruise control usage. Releasing the throttle pedal will return the vehicle to the previously programmed set speed.

**To Set a Lower Set Speed**—choose one of three ways to set a lower set speed.

- Press and hold the set/coast (SET/CST) switch located on the steering wheel until the lower set speed is reached. Then release the switch.
- Press and release the set/coast switch. Each press of the switch will decrease the set speed by 1 mph (1.6 km/h).
- Press and release the set/coast switch and depress the brake pedal until the desired speed is reached. Then press the set/coast switch.

**To Disengage the Speed Control**—depress the brake pedal or the clutch pedal. Disengaging the

# Instruments and Controls Identification

speed control will not erase the previously programmed set speed. Pressing the OFF switch will erase the previously programmed set speed.

**To Return to a Set Speed**—press the resume/accelerate (RSM/ACCL) switch for about three seconds.

**IMPORTANT:** The use of radio transmitting equipment that is not FCC approved may cause the speed control to malfunction. Therefore, use only properly installed FCC approved radio transmitting equipment in your vehicle.

**To Turn Off Cruise Control**—press the OFF switch ([Fig. 2.24](#)) located on the steering wheel. Once the cruise control is turned off, the previously programmed set speed will be deleted.

## Stationary Throttle Control Operation

On all engines except CAT 3126, the cruise control may also be used as a throttle control for PTO applications under the following conditions:

- the parking brake is set
- the clutch and accelerator pedals are released

To operate the cruise control:

- Press the ON switch located on the steering wheel;
- Press and hold the set/coast (SET/CST) switch located on the steering wheel until the desired rpm has been reached;
- Adjust the rpm by alternately pressing the set/coast and resume/accelerate (RSM/ACCL) switches.

The cruise control now functions as a throttle control.

To turn off the throttle control:

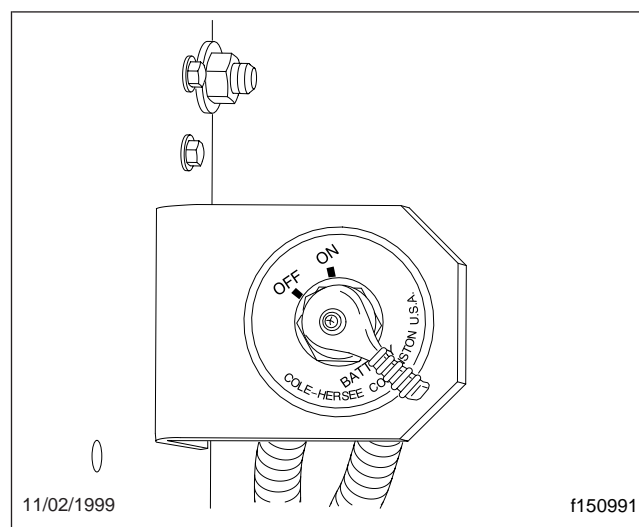
- Press the OFF switch located on the steering wheel, or depress the throttle pedal or the clutch pedal.

On CAT 3126 engines, the PTO will only operate if the vehicle is in neutral. This feature can be overridden by a special service tool. See your dealer or service representative for more information.

## Battery-Isolation Switch

The battery-isolation switch (see [Fig. 2.26](#)) is located on the cab floor at the left of the driver's seat, or in-

side the battery box. The battery-isolation switch reduces the power to the cab and engine power wiring. Use it whenever the vehicle is to be put out of service for extended periods.



**Fig. 2.26, Battery-Isolation Switch**

**IMPORTANT:** The battery-isolation switch does not completely disconnect the batteries from the electrical system. For service operations that require that the batteries be disconnected, always shut down the engine and remove the negative battery cables.

**NOTE:** Whenever battery power is disconnected, clocks and electronically tuned radios must be reset.

## Transmission Controls

If so equipped, the transmission range control valve and splitter valve are attached to the gearshift knob. Transmission shift pattern labels are located inside the cab.

Refer to [Chapter 8](#) for complete manual transmission operating instructions.

Refer to [Chapter 8](#) for information on the automatic transmission controls.









## Warning and Indicator Lights

Dash lightbars have warning and indicator lights that may be lettering or icons. Up until December 31,

# Instruments and Controls Identification

2006, the warning and indicator lights were a mixture of ISO icons and lettering. Since January 2007, ISO icons are used for all standard warning and indicator

lights on the dash lightbar. See [Table 2.1](#) for descriptions of the icons.

Warning and Indicator Light Icons		
	Check Engine (amber)	Indicates an undesirable engine condition is detected or recorded. The vehicle can still be driven. If the condition gets worse, the stop engine or engine protection light will illuminate.
	Stop Engine or Engine Protect (red)	Indicates a serious fault that requires the engine shut down immediately. The engine ECU will reduce the maximum engine torque and speed, and, if the condition does not improve, will shut down the engine within 30 seconds of the light illuminating. The driver must safely bring the vehicle to a stop on the side of the road and shut down the engine as soon as the red light is seen. If the engine shuts down while the vehicle is in a hazardous location, the engine can be restarted after turning the key to the OFF position for a few seconds.
	High Exhaust System Temperature (HEST) Lamp (amber)	Slow (10-second) flash indicates a regeneration is in progress, and the driver is not controlling the engine idle speed.  Steadily illuminated indicates a regeneration is in progress, with high exhaust temperatures at the outlet of the tail pipe, if the speed is below 5 mph (8 km/h). It does not signify the need for service; it only alerts the vehicle operator of high exhaust temperatures. See the engine operation manual for details.
	Diesel Particulate Filter (DPF) Lamp (amber)	Steadily illuminated indicates a regeneration is required. Change to a more challenging duty cycle, such as highway driving, to raise exhaust temperatures for at least 20 minutes, or perform a parked regeneration. See the engine operation manual for details.  Blinking indicates that a parked regeneration is required immediately. An engine derate and shutdown will occur. See the engine operation manual for details on how to perform a stationary regeneration.
	Malfunction Indicator Lamp (MIL) (amber)	Indicates an engine emissions-related fault, including, but not limited to the aftertreatment system. See the engine operation manual for details.
	Tractor ABS Lamp (amber)	Indicates a problem with the ABS is detected. Repair the tractor ABS immediately to ensure full antilock braking capability.
	Trailer ABS Lamp (amber)	Indicates a fault is detected with the trailer ABS.
	Left-Turn Signal (green)	Flashes on and off whenever the outside turn signal lights are flashing.

# Instruments and Controls Identification











Warning and Indicator Light Icons		
	Right-Turn Signal (green)	Flashes on and off whenever the outside turn signal lights are flashing.
	High-Beam Indicator (blue)	Indicates the headlights are on high beam.
	Low Air Pressure Warning Lamp (red)	Activates with a buzzer when air pressure in the primary or secondary air reservoir falls below 64 to 76 psi (440 to 525 kPa).
	High Coolant Temperature Warning Lamp (red)	Activates with a buzzer when the coolant temperature goes above a maximum level specified by the engine manufacturer (see the engine manual).
	Low Engine Oil Pressure Warning Lamp (red)	Activates with a buzzer when engine oil pressure goes below a minimum level specified by the engine manufacturer (see the engine manual).
	Parking/Emergency Brake Lamp (BRAKE!) (Red)	Indicates the parking brake is engaged, or hydraulic brake fluid pressure is low. A buzzer activates when the vehicle is moving over 2 mph (3 km/h) with the parking brake set.
	Fasten Seat Belt Lamp (red)	Illuminates for 15 seconds when the ignition key is turned to the ON position.
	Intake Heater Lamp (amber)	Indicates the intake air heater is active.
	Water in Fuel Lamp (amber)	Indicates that the fuel could contain water.
	Low Battery Voltage Lamp (red)	Indicates battery voltage is 11.9 volts or less.

Table 2.1, Warning and Indicator Light Icons

## Engine Protection Warning Lights

**IMPORTANT:** Drivers of electronically controlled engines should know the extent of the warning/warning-shutdown system for their vehicle before operating it. This information can be obtained from their Sterling dealer.

### Amber Check Engine Warning Light

When the amber Check Engine warning lamp comes on for any reason, the vehicle can still be operated, and the driver can proceed to the required destina-

tion. This condition should be reported to an authorized service center as soon as possible. See the engine manufacturer's engine operation and maintenance manual for details of the engine protection system in the vehicle. See [Fig. 2.27](#).

### Red Stop Engine Light

When the red Stop Engine lamp comes on, the computer has detected a major malfunction in the engine that requires immediate attention.

**IMPORTANT:** It is the operator's responsibility to shut down the engine to avoid serious damage.

# Instruments and Controls Identification

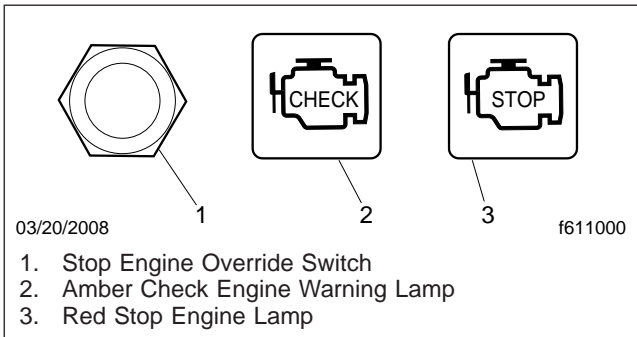


Fig. 2.27, Engine Protection Warning Lights

See the engine manufacturer's engine operation and maintenance manual for details of the engine protection system in the vehicle.

If the engine shuts down while the vehicle is in a hazardous location, the engine can be restarted after turning the key to the OFF position for a few seconds, to allow the driver to move the vehicle to a safe location.

## Stop Engine Override Switch



Using the override button so the engine operates for an extended period may result in engine damage. The operator has the responsibility to take action to avoid engine damage.

The vehicle may be equipped with a Stop Engine Override (SEO) switch, that can be used to override the shutdown sequence. This override resets the shutdown timer, restoring power to the level when the red stop engine lamp was illuminated. The switch must be recycled after five seconds to obtain a subsequent override.

## Instruments

### Tachometer, Optional

The tachometer (Fig. 2.28) indicates the engine speed in hundreds of revolutions per minute (rpm) and serves as a guide for shifting the transmission and keeping the engine in the appropriate rpm range.

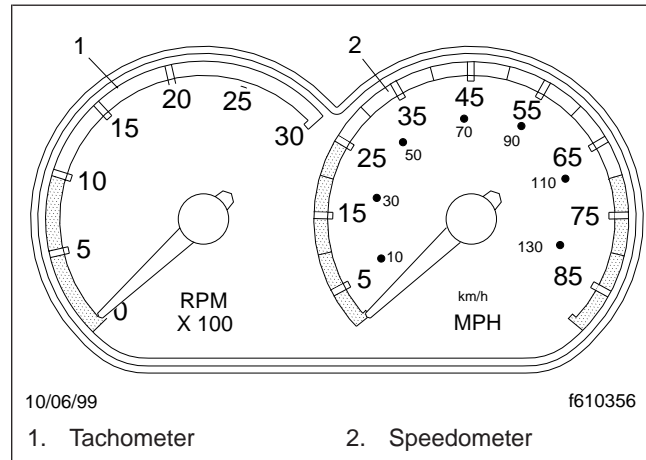


Fig. 2.28, Tachometer/Speedometer

## Speedometer

The speedometer (Fig. 2.28) registers speed in both miles per hour (mph) and kilometers per hour (km/h).

## Engine Oil Pressure Gauge



A sudden decrease or absence of oil pressure may indicate mechanical failure. Bring the vehicle to a safe stop and investigate the cause to prevent further damage. Do not operate the engine until the cause has been determined and corrected.

Refer to the engine operation manual for the specific safe-operating range for your vehicle. See Fig. 2.29.

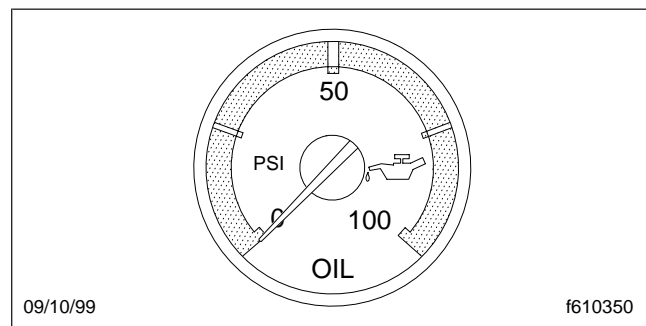
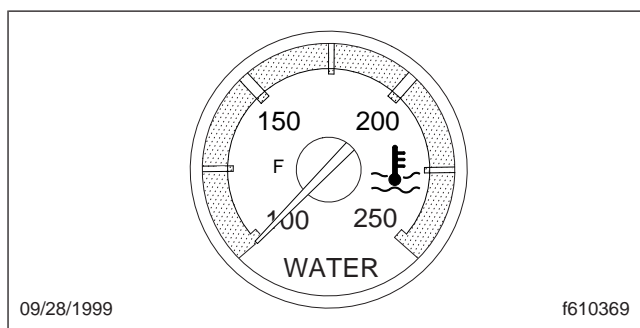


Fig. 2.29, Engine Oil Pressure Gauge

## Coolant Temperature Gauge

During normal operation, the coolant temperature gauge should read 180 to 210°F (82 to 99°C). Refer to the engine operation manual for the specific safe-operating range for your vehicle. See **Fig. 2.30**. If the temperature remains below normal or exceeds the maximum, inspect the cooling system to determine the cause. Refer to **Group 20** in the *Acterra® Workshop Manual* for troubleshooting and repair procedures.



**Fig. 2.30, Coolant Temperature Gauge**

## Voltage Reading



**Gel cell batteries can be damaged if the battery voltage is allowed to drop below 12.0 volts or if the charging voltage is more than 14.1 volts. Start the engine to recharge the gel cell before the battery becomes fully discharged. If an external charger is needed, disconnect the gel cell battery and use only an external battery charger that has been approved for gel cell batteries.**

The voltage reading indicates the vehicle charging system voltage when the engine is running, and the battery voltage when the engine is stopped. By monitoring the voltage reading, you can be aware of potential charging system problems and have them fixed before the batteries discharge enough to create starting difficulties.

The voltage reading will normally show approximately 13.7 to 14.1 volts when the engine is running. The voltage of a fully charged battery is 12.7 to 12.8 volts when the engine is stopped. A completely discharged battery will produce only about 12.0 volts. The voltage reading will indicate lower voltage as the vehicle

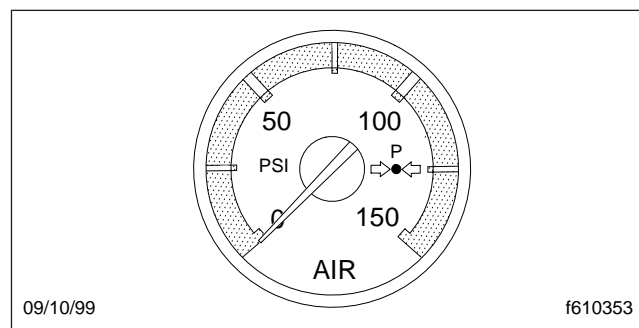
is being started or when electrical devices in the vehicle are being used.

If the voltage reading shows an undercharged or overcharged condition for an extended period, have the charging system and batteries checked at a repair facility.

On a vehicle equipped with a battery isolator system, the voltage reading shows the average voltage of all the batteries when the engine is running. When the engine is stopped, the voltage reading shows only the gel cell battery voltage and does not indicate the voltage of the engine-starting batteries.

## Primary and Secondary Air Pressure Gauges

Air pressure gauges (**Fig. 2.31** and **Fig. 2.32**) register the pressure in the primary and secondary air systems. Normal pressure, with the engine running, is 100 to 120 psi (689 to 827 kPa) in both systems. A low air pressure warning light comes on and a buzzer sounds when air pressure in either the primary or secondary system drops below a minimum pressure of 60 psi (414 kPa). When the engine is started, the warning light and buzzer remain on until air pressure in both systems exceeds minimum pressure.



**Fig. 2.31, Primary Air Pressure Gauge**

## Fuel Gauge

The fuel gauge (**Fig. 2.33**) indicates the level of fuel in the fuel tank(s).

# Instruments and Controls Identification

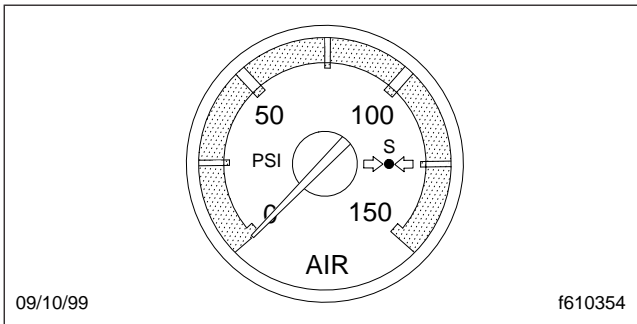


Fig. 2.32, Secondary Air Pressure Gauge

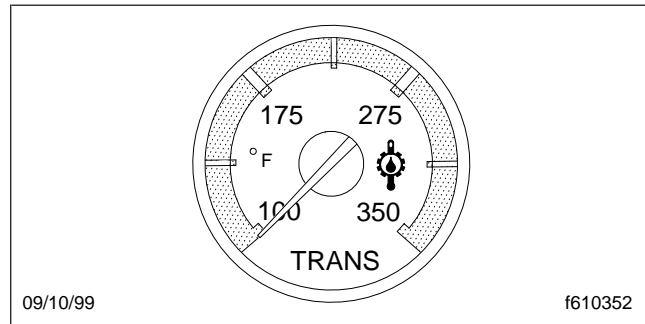


Fig. 2.34, Transmission Oil Temperature Gauge

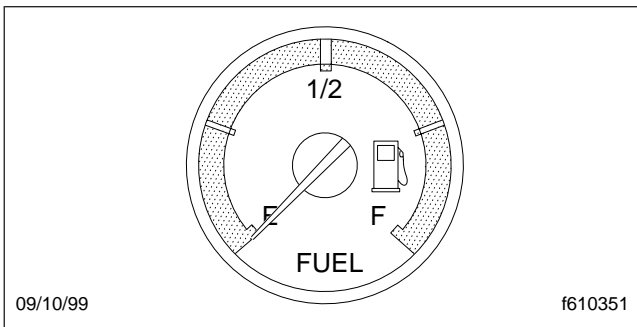


Fig. 2.33, Fuel Gauge

## Transmission Oil Temperature Gauge, Optional



A sudden increase in oil temperature that is not caused by a load increase may indicate mechanical failure. Bring the vehicle to a safe stop and investigate the cause to prevent further damage. Do not operate the engine until the cause has been determined and corrected.

During normal operation, the transmission oil temperature gauge (Fig. 2.34) reading should not exceed 250°F (121°C).

## Forward and Rear Axle Oil Temperature Gauges, Optional



A sudden increase in oil temperature that is not caused by a load increase may indicate mechanical failure. Bring the vehicle to a safe stop and

investigate the cause to prevent further damage. Do not operate the engine until the cause has been determined and corrected.

During normal operation, forward and rear axle oil temperature gauges (Fig. 2.35 and Fig. 2.36) should read between 150 and 230°F (65 and 110°C).

Under heavy loads, such as when climbing steep grades, temperatures up to a maximum of 250°F (121°C) are not unusual.

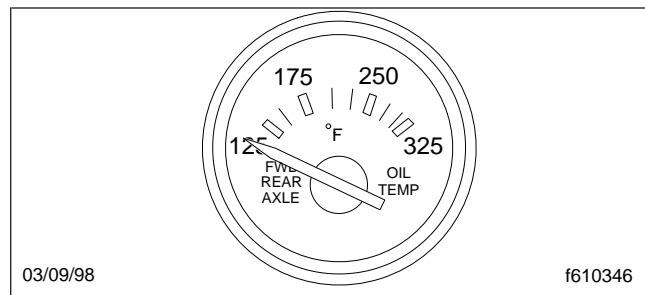


Fig. 2.35, Forward Rear Axle Oil Temperature Gauge

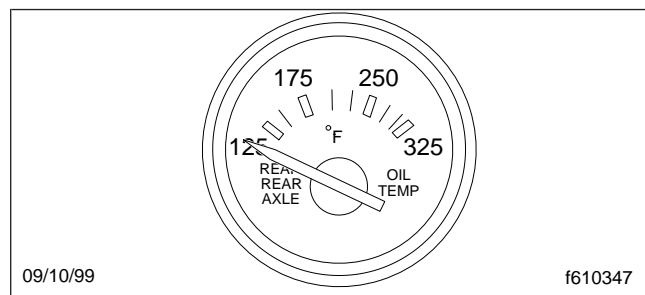


Fig. 2.36, Rearmost Axle Oil Temperature Gauge

## Application Air Pressure Gauge, Optional

An application air pressure gauge (Fig. 2.37) registers the air pressure being used to apply the brakes, and should be used for reference only. The gauge will not register air pressure until the foot brake pedal is depressed or the trailer hand brake is applied.

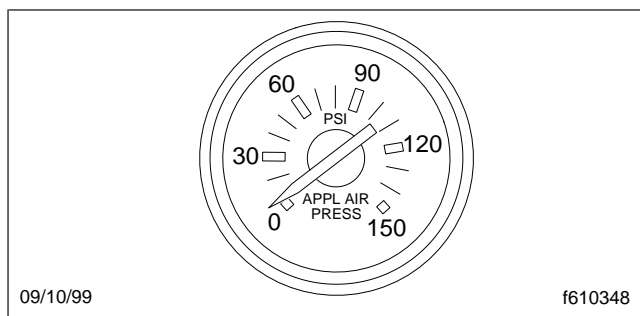


Fig. 2.37, Application Air Pressure Gauge

## Intake Air Restriction Indicator

The intake air restriction indicator (Fig. 2.38) measures the vacuum on the engine side of the air cleaner at the air cleaner outlet. Vacuum is measured in inH<sub>2</sub>O (inches of water). If the intake air restriction indicator stays locked at or above the service values shown in Table 2.2, the air cleaner needs to be serviced. After the air cleaner is serviced, push the reset button on the intake air restriction indicator to reset the indicator.

NOTE: Rain or snow can wet the filter, which can temporarily cause a higher than normal reading.

Intake Air Restriction Indicator Values		
Engine Type	Initial inH <sub>2</sub> O	Service inH <sub>2</sub> O
Caterpillar	15	25
Cummins	10	25
Mercedes-Benz	10	22
Detroit Diesel	12	20

Table 2.2, Intake Air Restriction Indicator Values

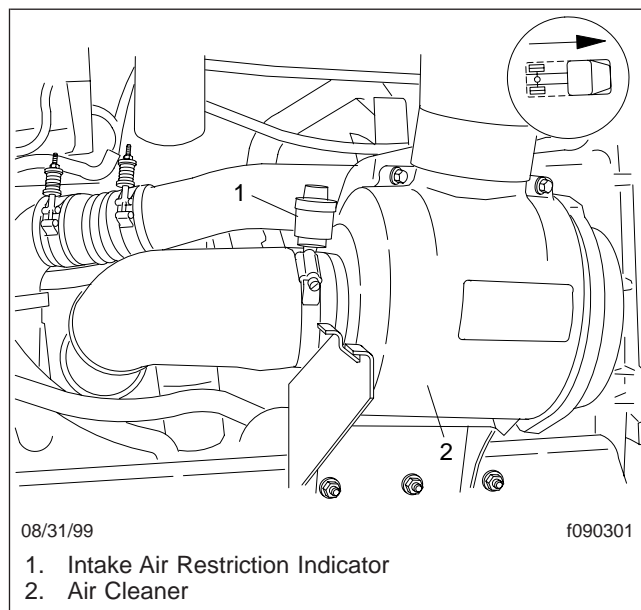


Fig. 2.38, Intake Air Restriction Indicator

## Intake Air Restriction Indicator, Dash-Mounted, Optional

The intake air restriction indicator (Fig. 2.39) measures the vacuum on the engine side of the air cleaner at the air cleaner outlet. Vacuum is measured in inH<sub>2</sub>O (inches of water). If the intake air restriction indicator stays locked at or above the service values shown in Table 2.2, the air cleaner needs to be serviced. After the air cleaner is serviced, push the reset tab on the intake air restriction indicator to reset the indicator.

NOTE: Rain or snow can wet the filter, which can temporarily cause a higher than normal reading.

## Instrumentation Control Unit 4 (ICU4)

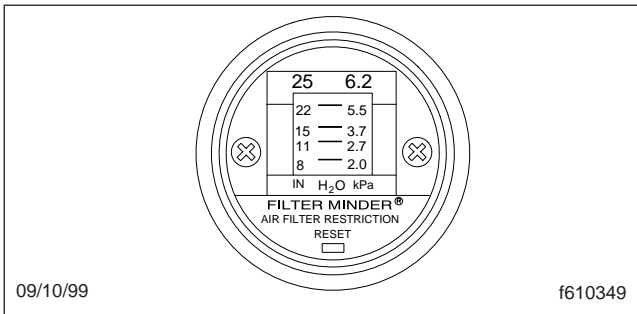
The ICU4 instrument cluster is an individual gauge cluster, with a lightbar with a driver message display screen, and integrated warning and indicator lights. See Fig. 2.40 for a typical layout of the gauges.

Standard gauges are:

- speedometer
- engine-coolant temperature gauge



# Instruments and Controls Identification

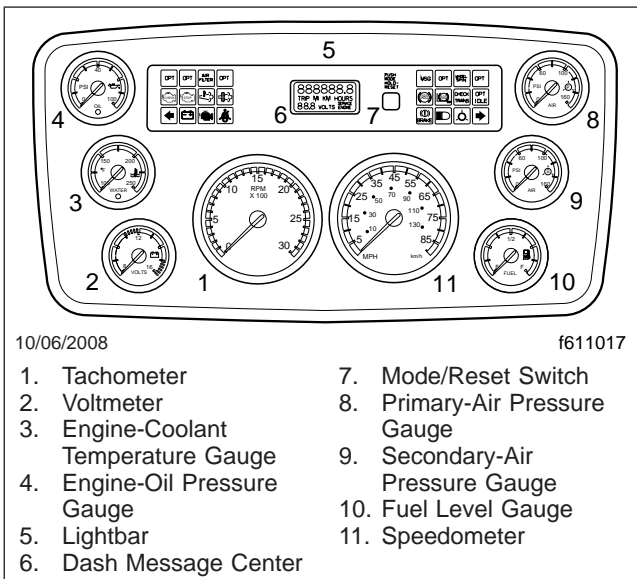


**Fig. 2.39, Intake Air Restriction Indicator, Dash-Mounted**

- engine-oil pressure gauge
- voltmeter
- fuel gauge
- air gauges

The following gauges have a warning light on the gauge:

- engine-coolant temperature (high)
- engine-oil pressure (low)
- fuel level (low)



**Fig. 2.40, ICU4 Instrument Cluster**

## Buzzer and Chime

A buzzer sounds for three seconds during the self-test at start-up, and when the following conditions exist:

- low air pressure
- low oil pressure
- high coolant temperature
- the parking brake is applied and the vehicle is moving at a speed of at least 2 mph (3 km/h)

A chime sounds when the parking brake is off and the door is open, or when the headlights are on and the door is open.

## Ignition Sequence

When the ignition key is turned on, the ICU4 begins a self-test. During this process, all gauges controlled by the cluster sweep to full scale and return, the buzzer sounds for 3 seconds, the fasten seat belt warning light illuminates for 15 seconds, and the battery voltage, low air pressure, and parking brake warning lights illuminate then turn off. Then the software revision level of the ICU4 is displayed, followed by active faults, if any, then the odometer display.

## Mode/Reset Switch

The mode/reset switch controls the display of the odometer, trip miles and hours, engine miles and hours, service cycle screens, fault code screens, and oil level screens (on some Mercedes-Benz engines; if equipped and enabled).

With the parking brake released, only the basic function screens, which include odometer, trip miles, and trip hours, can be accessed. Park the vehicle and set the parking brake to access additional screen functions.

## Basic Function Screens

When the odometer is displayed, push the mode/reset switch once to display trip distance, and push it again to display trip hours. Both numbers are calculated from the last time the value was reset. Hold the switch when either number is displayed, to reset the value to zero. See [Fig. 2.41](#).

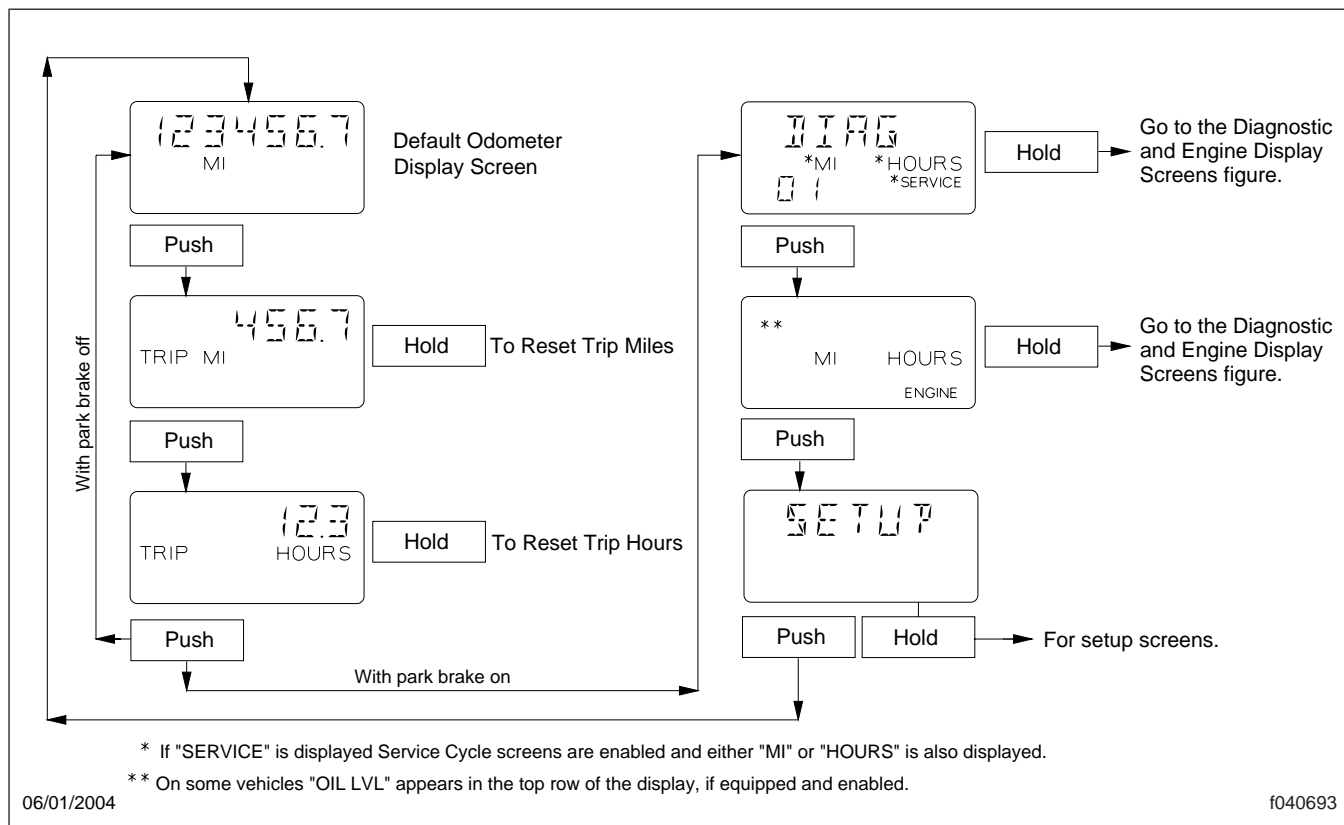


Fig. 2.41, ICU4 Basic Function Screens

## Diagnostic Screens

During vehicle start-up, with the parking brake on, the ICU4 displays any active fault codes for three seconds each, until the parking brake is released. While the active fault codes are on display, push the mode/reset switch once to display the initial diagnostic screen (DIAG) and the total number of active faults. See Fig. 2.42.

If service cycle screens are enabled, and service distance or time has been exceeded, the text SERVICE will be displayed with the other fault messages. This informs the driver that the service interval has been exceeded, and vehicle service is required.

Specific fault code information can be displayed only while the vehicle is parked and the parking brake set. When the odometer screen is displayed, push the mode/reset switch until the DIAG screen is displayed, then hold the switch to enter the fault code screen sequence. Once the initial fault code is displayed, push the switch to cycle through additional diagnostic

codes relating to the first fault. Hold the switch to display additional faults or return to the DIAG screen. If service cycle screens are enabled, service interval information is displayed before fault code information is displayed.

When the word SERVICE appears on the DIAG message display screen, service cycle screens are enabled. Hold the mode/reset switch at the DIAG screen to display miles or hours remaining until the next scheduled service. When MI appears on the DIAG screen, service miles are enabled; when HOURS appears on the screen, service hours are enabled. Either service miles or hours can be enabled, but not both. When service miles or hours has been exceeded, the number flashes to indicate service is overdue.

## Engine Screens

Push the mode/reset switch once following the DIAG screen and the word ENGINE is displayed in the lower right corner of the digital display. Hold the





# Instruments and Controls Identification

If NO is selected, the display will sequence to the odometer display.

The last screen in the SETUP menu, RESET EE is for resetting certain parameters to the original settings. Hold the mode switch to reset the ABS rollcall, sensor fault codes, and engine oil level screens. Push the mode switch to sequence the display to the odometer setting.

## Instrumentation Control Unit 3 (ICU3 and ICU3 '07)

The instrumentation control unit (ICU) houses most warning and indicator lights, most gauges, and a message display screen. Warning messages and diagnostic fault codes will appear in the message display screen. The dash lightbars have warning and indicator lights that may be lettering or icons. Up until December 31, 2006, the warning and indicator lights are a mixture of ISO icons, and lettering. Since January 2007, ISO icons are used for all standard warning and indicator lights on the dash lightbar. See [Table 2.1](#) for an explanation of the icons.

There can be up to eight gauges on the ICU3 instrument cluster, six electronic gauges and two mechanical gauges. See [Fig. 2.44](#). Only air gauges operate mechanically. The ICU3 cannot drive gauges located on the control panel.

The dash message center is the heart of the ICU3. It has two parts, a set of up to 26 warning and indicator lights and a message display screen. The message display screen is a one-line by seven-character liquid crystal display (LCD) that normally shows the odometer reading. Below the odometer reading is a smaller one-line by three-character LCD that shows the voltmeter reading.

The message display screen will also display the trip distance, trip hours (engine hours), and service diagnostics if the vehicle has this option.

Use the instrument and control panel dimmer switch to increase or decrease the brightness of the message display screen.

There can be up to 26 warning and indicator lights installed in the ICU3. See [Fig. 2.45](#) and [Fig. 2.46](#).

There are four rows of lights in the dash message center. Lights installed in the top row are optional and their positions may vary. The lights in the bottom

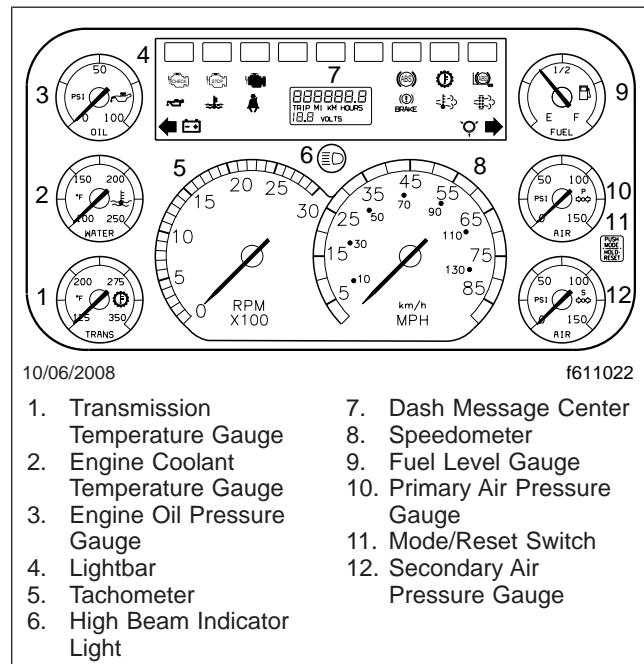


Fig. 2.44, ICU3 ('07 shown)

three rows are installed in fixed positions on all vehicles. Most are standard, but a few are optional.

## ICU3 Ignition Sequence

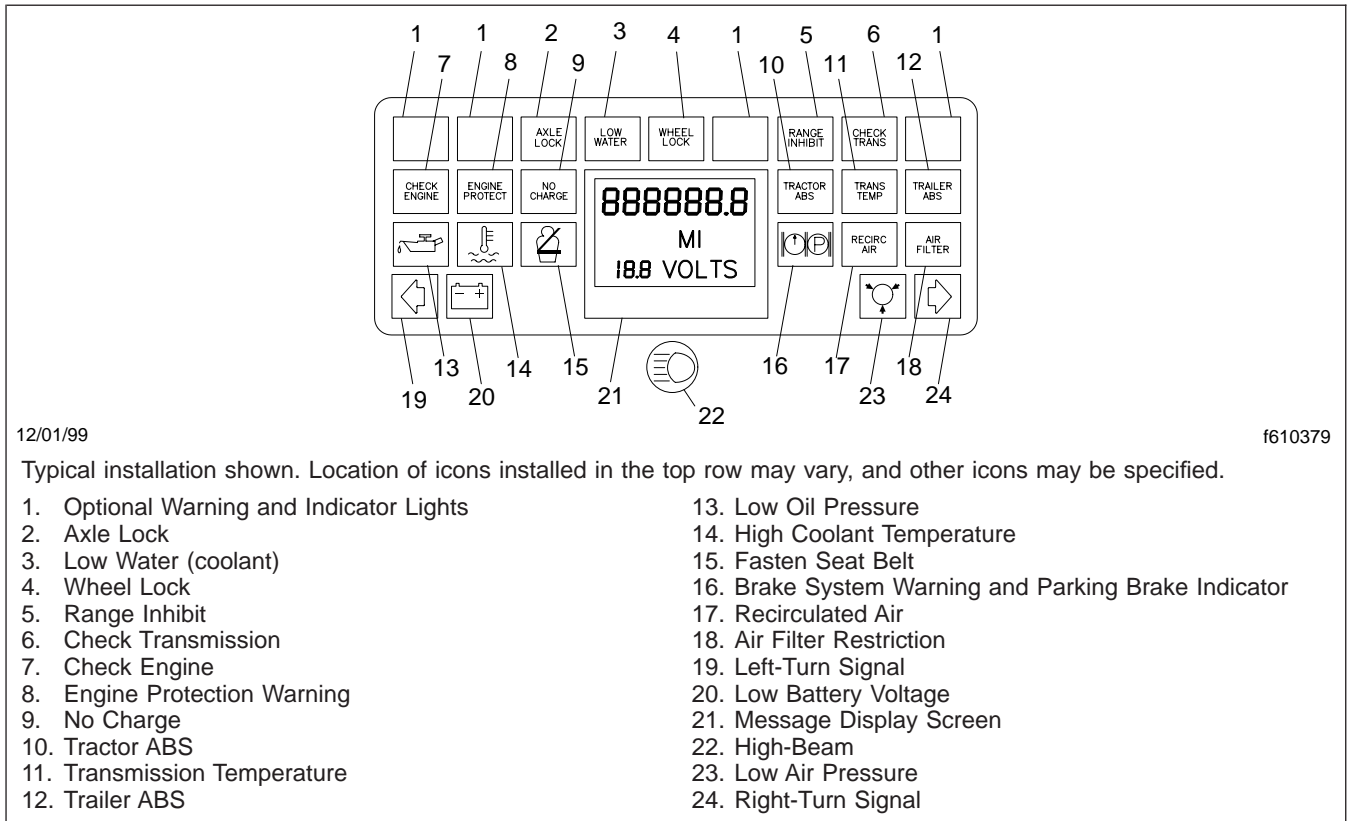
If the headlights are turned on, the message display screen displays the odometer reading. When the ignition is turned on, all the electronic gauges complete a full sweep of their dials, the warning and indicator lights light up, and the buzzer sounds for three seconds.

NOTE: The air gauges do not sweep.

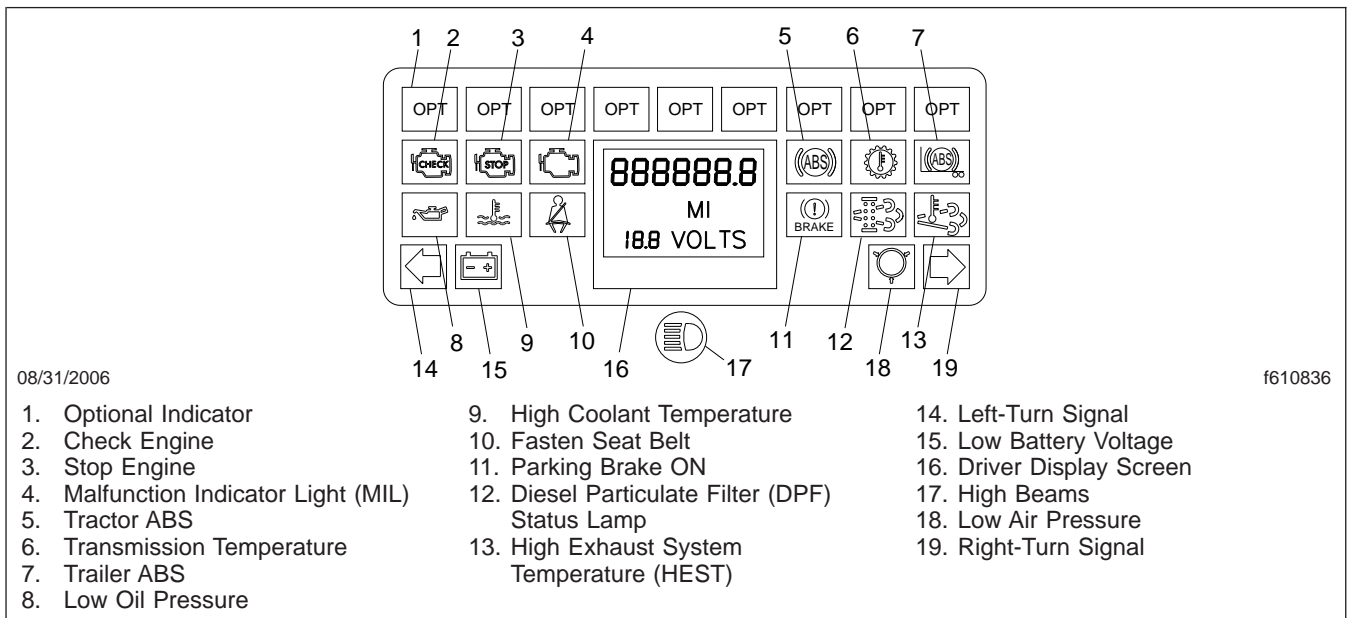
The following lights come on during the ignition sequence:

- high coolant temperature warning
- low engine oil pressure warning
- low air pressure warning
- parking brake indicator
- engine protection warning
- check engine warning
- tractor ABS
- trailer ABS

# Instruments and Controls Identification



**Fig. 2.45, ICU3 Dash Message Center**



**Fig. 2.46, ICU3 '07 Dash Message Center**

# Instruments and Controls Identification

---

NOTE: Although the engine and ABS warning lights come on during the ignition sequence, they are not controlled by the ICU3 or ICU3 '07 but by their own system ECU (electronic control unit).

Once the ignition switch has been turned on, the ICU3 or ICU3 '07 performs a self-test to look for active faults. During the first half of the self-test, all segments of the message display screen display **888888.8**. The voltmeter display also comes on with the value **18.8**. During the second half of the self-test, the software revision level is displayed.

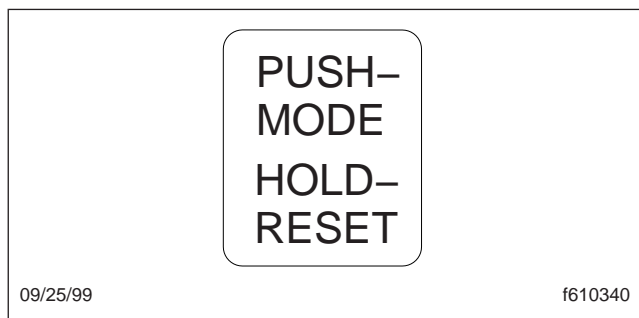
If there are no active faults, the screen displays the odometer reading.

If the ICU3 or ICU3 '07 has received active fault codes from other devices, it displays them, one after the other, until the parking brake is released or the ignition switch is turned off.

A list of fault codes and definitions can be found in **Group 54** of the *Acterra® Workshop Manual*. Once the parking brake is released, the ICU3 or ICU3 '07 displays the odometer reading again.

## Mode/Reset Switch

The mode/reset switch ([Fig. 2.47](#)) is located on the right side of the instrument cluster. The mode/reset switch is used to scroll through the displays on the message display screen, and to reset the trip distance and trip hours values to zero.



**Fig. 2.47, Mode/Reset Switch**

See [Fig. 2.48](#) for the state diagram for the LCD display cycle.

NOTE: The systems diagnostics test is used by trained personnel to retrieve fault codes and other diagnostic information pertaining to the vehicle.

When the odometer reading is displayed and the parking brake is applied:

- Press the mode/reset switch once and the trip distance will display.
- Press the mode/reset switch a second time and the trip hours (engine hours) will display.
- Press the mode/reset switch a third time and the SELECT screen and the current units, MI or KM, will display.
- Press the mode/reset switch a fourth time to return to the odometer reading.

To reset trip miles and/or trip hours to zero, press the mode/reset switch for 1 second or longer. To toggle between MI (miles) or KM (kilometers), press the mode/reset switch while in the SELECT screen.

## NGI Instrument Cluster, Optional Instruments

The NGI instrument cluster became an option in January of 2002.

Each of its gauges is an individually replaceable unit. The instrument control unit (ICU) is located in the speedometer and receives information from the various sensors installed on the vehicle and feeds it to the electronic gauges. Only the air gauges operate mechanically.

## Lightbar

The lightbar has 3 rows of 7 warning lights. See [Fig. 2.49](#). The 7 telltales on the top row of the lightbar will vary depending on the vehicle configuration and customer preference. The 2 lower rows contain 14 standard telltales as shown in [Table 2.3](#).

# Instruments and Controls Identification

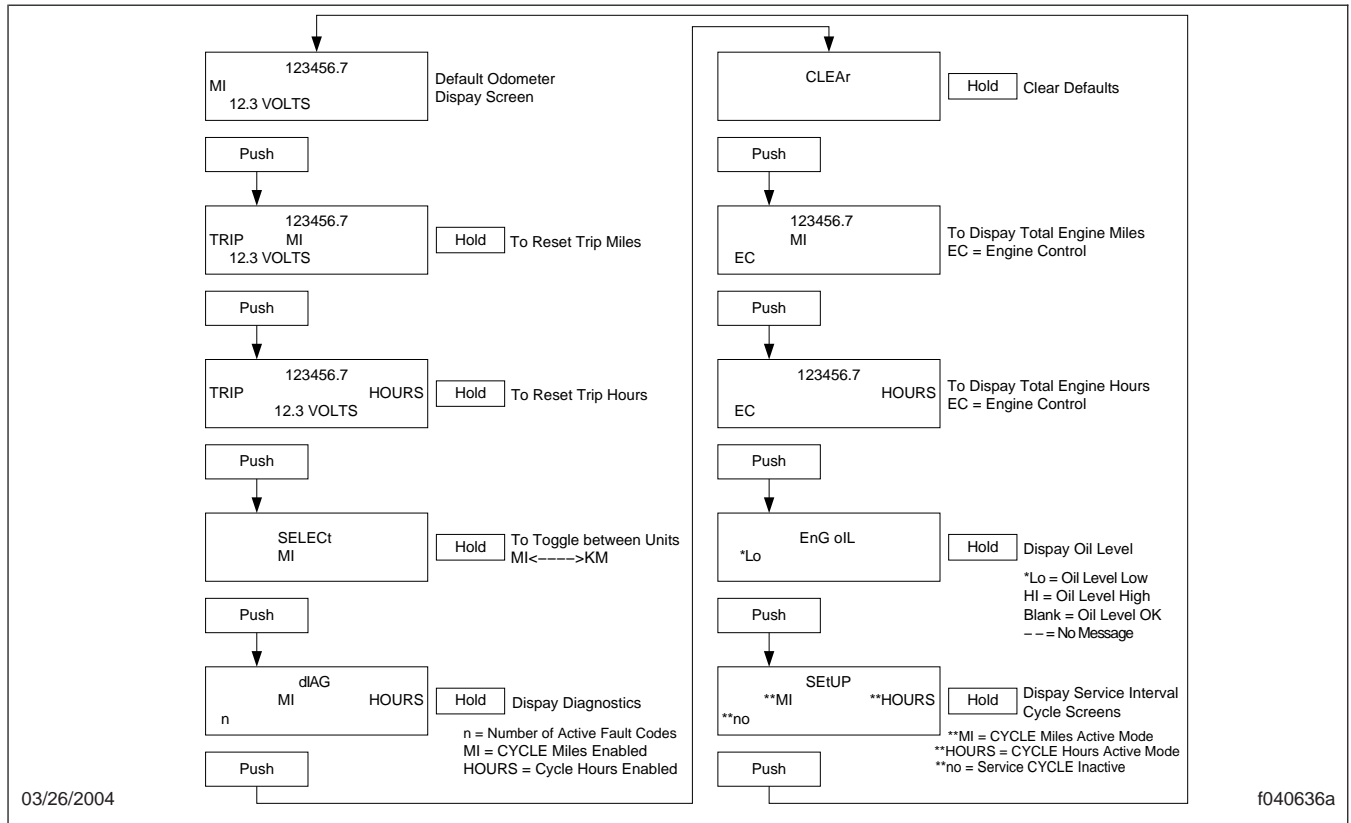


Fig. 2.48, ICU3 Mode Reset LCD Display Cycle

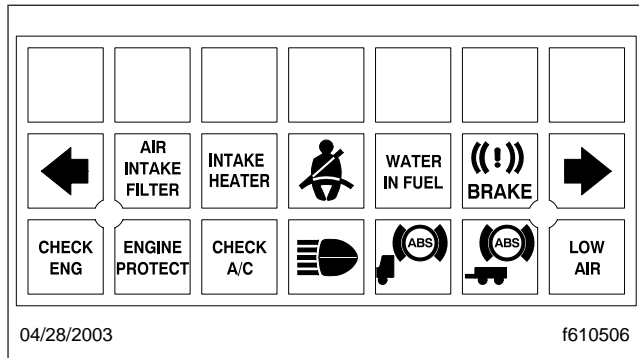


Fig. 2.49, NGI Lightbar

NGI Lightbar Standard Telltales	
Light	LED Color
High Beam Headlamps	Blue
Tractor ABS (Antilock Brake System)	Amber
Parking/Emergency Brake	Red
Air Intake Filter Restriction	Amber
Right Turn Signal	Green
Trailer ABS	Amber
Water in Fuel	Amber
Intake Heater	Amber
Check A/C	Amber
Low Air	Red

Table 2.3, NGI Lightbar Standard Telltales

NGI Lightbar Standard Telltales	
Light	LED Color
Left Turn Signal	Green
Check Engine	Amber
Engine Protection	Red
Fasten Seat Belt Symbol	Red

## Message Center

The NGI message center is a one row, seven character liquid crystal display (LCD), located on the speedometer, that displays the following information:



# Instruments and Controls Identification

- Odometer
- Trip Odometers (two)
- Engine Hour Meter
- System Diagnostic Menu
- NGI-specific warning messages

The odometer, hour meter, and trip odometers are primary screens. When a primary screen is displayed for 3 seconds or more it becomes the default screen. The default screen is displayed at ignition and will remain so until manually adjusted using the Mode and Set buttons.

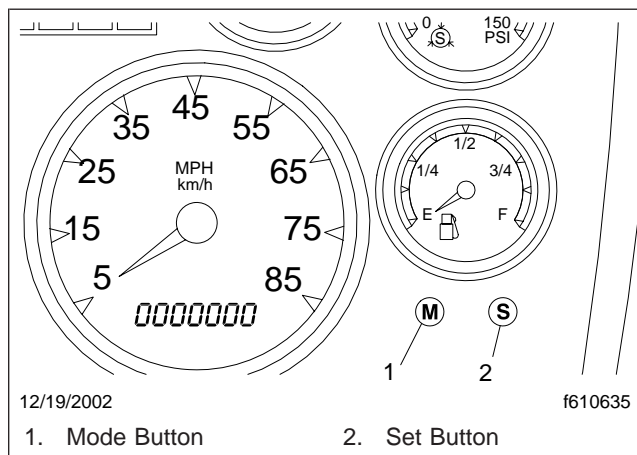
## Mode and Set Buttons

The Mode and Set buttons are located in the lower right corner of the instrument cluster. See [Fig. 2.50](#). Pressing the Mode button cycles through the various functions. Pressing the Set button selects the desired function. See [Fig. 2.51](#). In the Odometer mode, the Set button toggles to MI or KM. In the Trip 1 and 2 Odometer modes, the Set button resets the Trip meter to zero. In the Engine hours mode, total engine hours are displayed. This is not resettable. In the System mode, the Set button initiates the System Diagnostics test and will display any warning messages that are present in the system.

**NOTE:** The systems diagnostics test is used by trained personnel to retrieve fault codes and other diagnostic information pertaining to the vehicle.

To run the system diagnostics, the following conditions must be met:

- ignition on;
- parking brake set;
- road speed below 2 mph;
- engine rpm at or below 1000;
- no low air pressure warning in effect.



**Fig. 2.50, Mode and Set Buttons**

# Instruments and Controls Identification

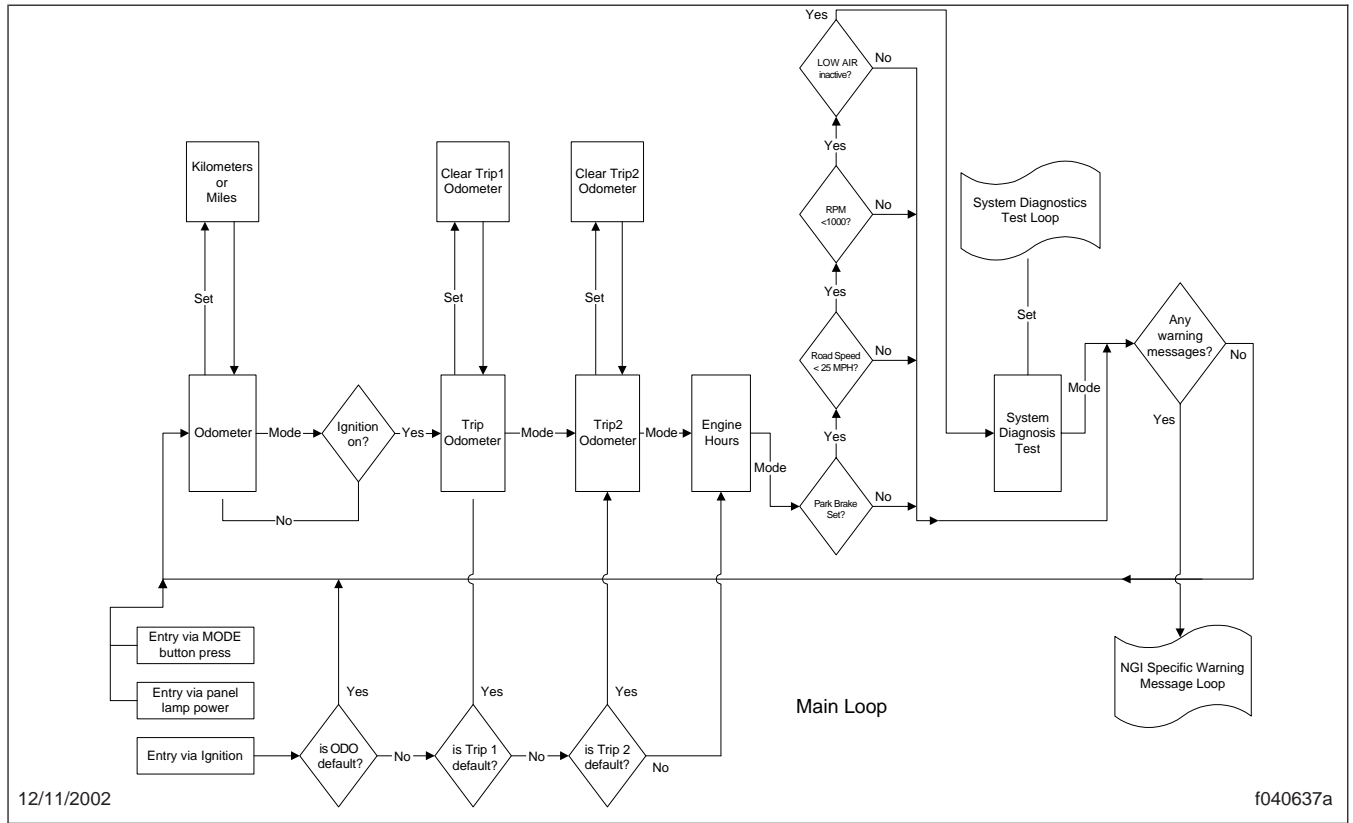


Fig. 2.51, State Diagram for LCD Display

# 3

## Vehicle Access and Features

---

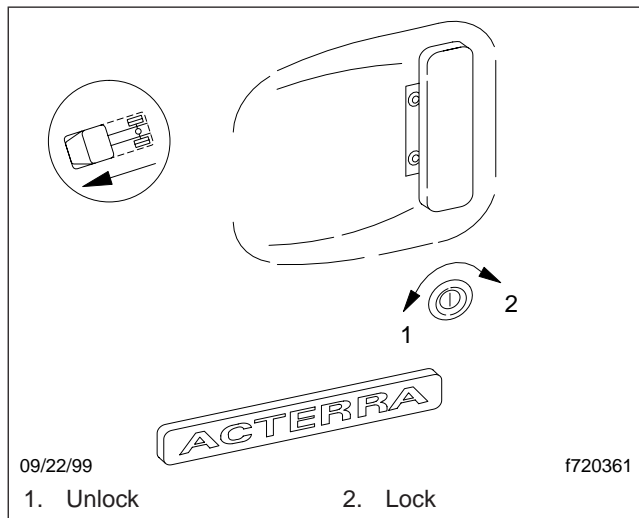
Cab Door Locks and Handles .....	3.1
Door Windows .....	3.1
Cab Entry and Exit .....	3.2
Hood Tilting .....	3.4
Back-of-Cab Grab Handles, Steps, and Deck Plate .....	3.4
Fuse, Relay, and Circuit Breaker Identification .....	3.5

# Vehicle Access and Features

## Cab Door Locks and Handles

The key that operates the ignition switch also locks and unlocks the cab doors from the outside. The lock cannot be operated when the door is open.

To unlock the driver's door from outside the cab, insert the key in the lockset and turn the key counterclockwise (**Fig. 3.1**). Pull the handle out to open the door. To lock the driver's door, insert the key in the lockset and turn the key clockwise.



**Fig. 3.1, Driver's Door Lock and Handle**

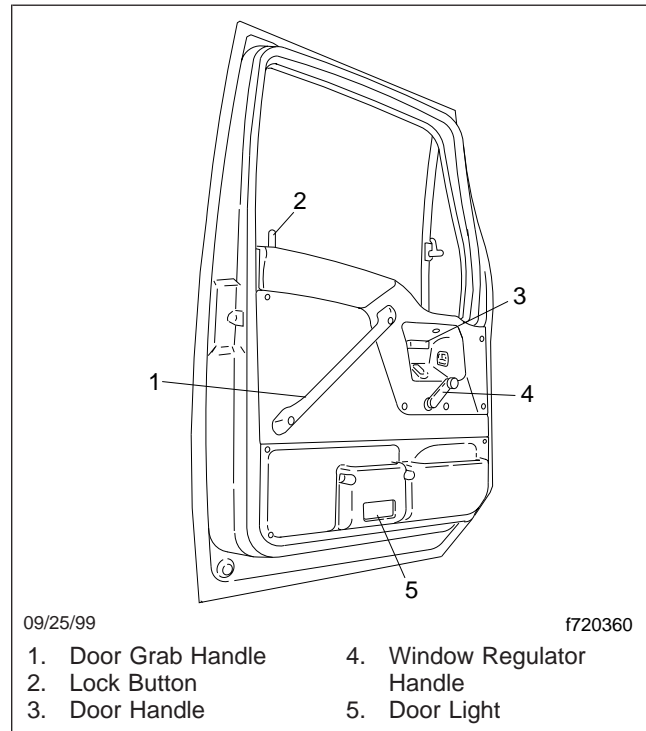
To unlock the passenger's door from outside the cab, insert the key in the lockset and turn the key clockwise. Pull the handle out to open the door. To lock the passenger's door, insert the key in the lockset and turn the key counterclockwise.

To lock the door from inside the cab, close the door, then push the lock button down or push the **L** on the power lock switch. See **Fig. 3.2** and **Fig. 3.3**.

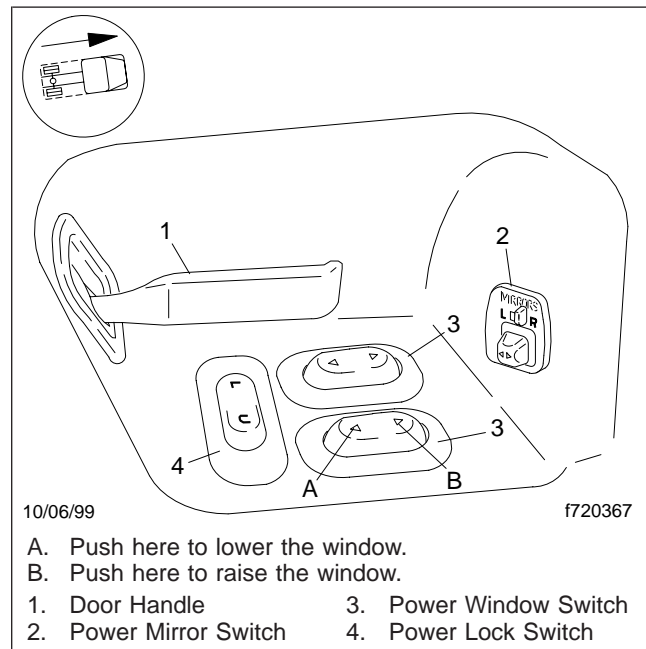
To open the door from the inside, pull the door handle toward you. This will unlatch the door whether or not it was locked. To unlock the door without unlatching it, pull up the lock button or press the **U** on the power lock switch.

## Door Windows

If the vehicle has manual window regulators, lower the driver's door window by turning the window regulator handle clockwise. To lower the passenger's



**Fig. 3.2, Door Interior**



**Fig. 3.3, Power Switches**

door window, turn the window regulator handle counterclockwise.

If the vehicle is equipped with power window switches, they are located on the door (Fig. 3.3). Push the dimpled end of the power window switch to lower the window. Push the raised end of the power window switch to raise the window.

## Cab Entry and Exit

### **WARNING**

**Wet or dirty shoe soles greatly increase the chance of slipping or falling. If your soles are wet or dirty, be especially careful when climbing onto, or down from, the back-of-cab area.**

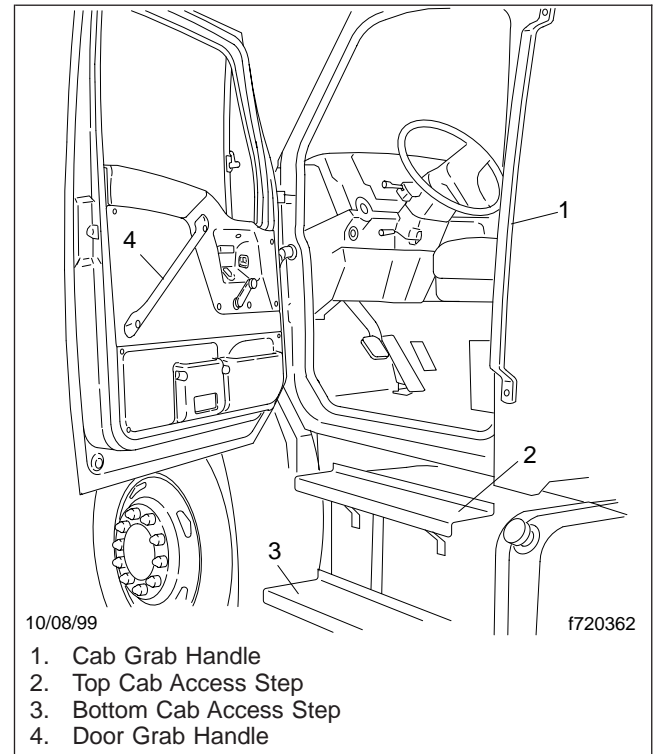
**Always maintain three-point contact with the back-of-cab access supports while entering and exiting the back-of-cab area. Three-point contact means both feet and one hand, or both hands and one foot, on the grab handles, steps, and deck plates. Other areas are not meant to support back-of-cab access, and grabbing or stepping in the wrong place could lead to a fall, and personal injury.**

**Be careful not to get hands or feet tangled in hoses or other back-of-cab equipment. Carelessness could cause a person to trip and fall, with possible injury.**

When entering or exiting the cab, use the grab handles and cab access steps as indicated in the following instructions. See Fig. 3.4 and Fig. 3.5.

### Entering the Driver's Side When There are Two Cab Access Steps

1. Open the driver's door and place anything that you are carrying in the cab.
2. Grasp the door grab handle with your left hand and the cab grab handle with your right hand.
3. Place your right foot on the bottom step and pull yourself up.
4. Place your left foot on the top step.
5. Grasp the steering wheel with your left hand and step into the cab with your right foot first.



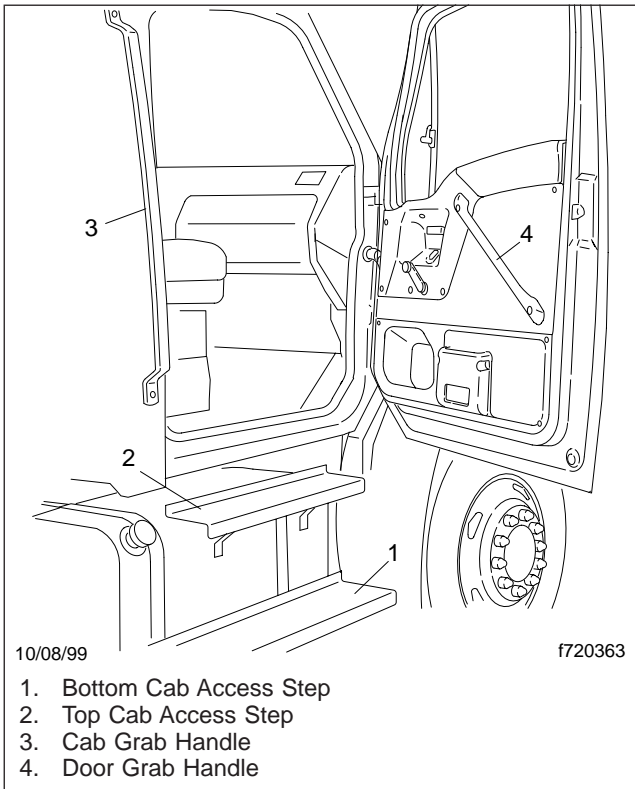
**Fig. 3.4, Driver's Side Cab Access Steps and Grab Handles**

6. Grasp the steering wheel with your right hand and pull yourself into the seat.

### Exiting the Driver's Side When There are Two Cab Access Steps

1. Do not attempt to exit the cab while carrying any items in your hands.
2. Grasp the steering wheel with both hands and place your left foot on the top step. Pivot your body so you're facing in to the cab.
3. Grasp the cab grab handle with your right hand.
4. Move your right foot to the bottom step.
5. Grasp the door grab handle with your left hand.
6. Step to the ground with your left foot first.

# Vehicle Access and Features



**Fig. 3.5, Passenger's Side Cab Access Steps and Grab Handles**

## Entering the Passenger's Side When There are Two Cab Access Steps

1. Open the passenger's door and place anything that you are carrying in the cab.
2. Grasp the cab grab handle with your left hand and the door grab handle with your right hand.
3. Place your left foot on the bottom step and pull yourself up.
4. Place your right foot on the top step.
5. Grasp the seat with your left hand and step into the cab with your left foot first.
6. Pull yourself into the seat.

## Exiting the Passenger's Side When There are Two Cab Access Steps

1. Do not attempt to exit the cab while carrying any items in your hands.

2. Grasp the door grab handle with your right hand and place your right foot on the top step.
3. Grasp the grab handle with your left hand.
4. Move your left foot to the bottom step.
5. Step to the ground with your right foot first.

## Entering the Driver's Side When There is One Cab Access Step

1. Open the driver's door and place anything that you are carrying in the cab.
2. Grasp the door grab handle with your left hand and the grab handle with your right hand.
3. Place your right foot on the cab access step.
4. Bring your left foot up to the cab floor and step up, bringing your right foot into place in the cab.
5. Grasp the steering wheel with your left hand and pull yourself into the seat.

## Exiting the Driver's Side When There is One Cab Access Step

1. Do not attempt to exit the cab while carrying any items in your hands.
2. Grasp the door grab handle with your left hand.
3. Move your left foot to the cab access step and grasp the grab handle with your right hand.
4. Bring your right foot down to the ground, then bring your left foot down to the ground.

## Entering the Passenger's Side When There is One Cab Access Step

1. Open the passenger's door and place anything that you are carrying in the cab.
2. Grasp the grab handle with your left hand and the door grab handle with your right hand.
3. Place your right foot on the cab access step.
4. Bring your left foot up to the cab floor and step up, bringing your right foot into place in the cab.
5. Grasp the seat with your left hand and pull yourself into the seat.

## Exiting the Passenger's Side When There is One Cab Access Step

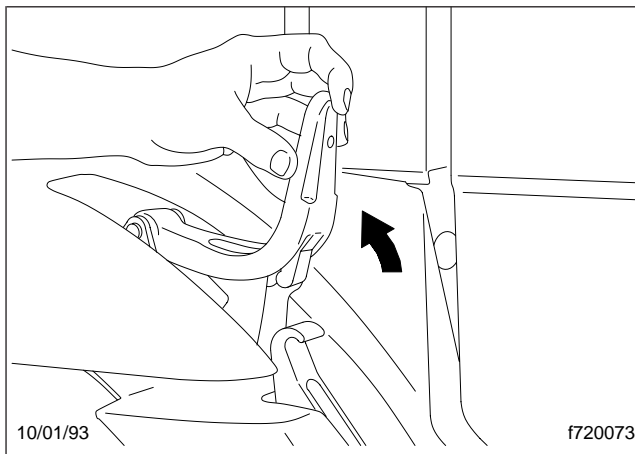
1. Do not attempt to exit the cab while carrying any items in your hands.
2. Grasp the door grab handle with your right hand.
3. Move your right foot to the cab access step, and grasp the grab handle with your left hand.
4. Bring your left foot down to the ground, then bring your right foot down to the ground.

## Hood Tilting

A grab handle at the front of the hood provides a hand-hold for hood tilting. Stop cables prevent the hood from overtravel. In the operating position, the hood is secured to the lower cab half-fenders by a hold-down latch on each side of the hood.

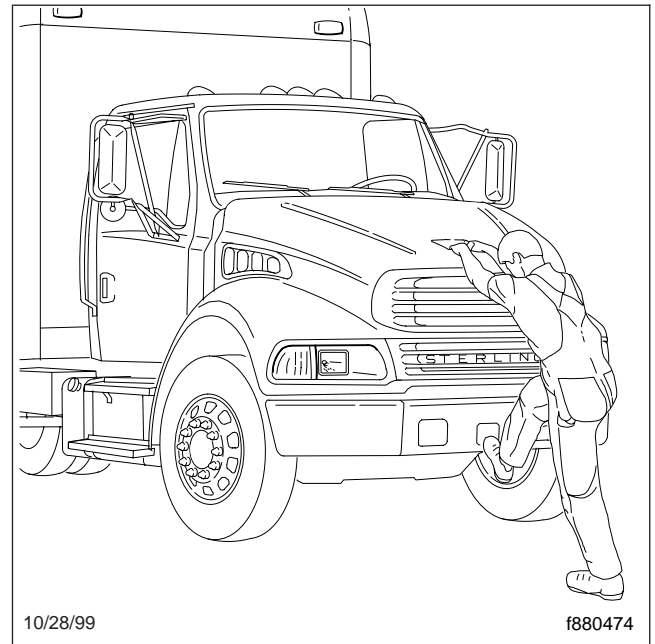
### To Tilt the Hood

1. Apply the parking brakes.
2. Release both hood hold-down latches by pulling the ends up. See [Fig. 3.6](#).



**Fig. 3.6, Unlatch the Hood**

3. Using the front bumper step and the hood handle, slowly tilt the hood until the stop cables support it. See [Fig. 3.7](#).



**Fig. 3.7, Tilting the Hood**

## CAUTION

**Do not let the hood free-fall to the full-open position. To do so could cause damage to the hood or hood straps.**

### To Return the Hood

1. Grasp the hood handle and lift the hood to the 45-degree position.
2. As the hood goes over center, use the bumper step and the hood handle to control the rate of descent to the operating position.
3. Make sure the hood is flush with the cowl, then secure the hood by engaging both hood hold-down latches.

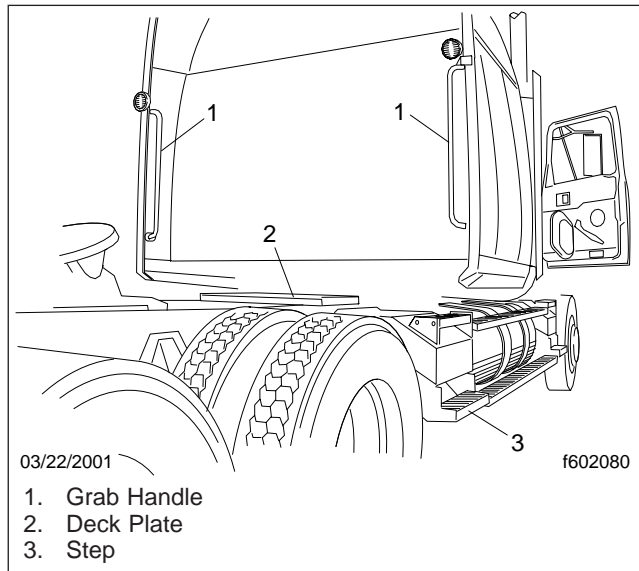
**IMPORTANT:** Make sure that both hold-down latches are fully engaged before operating the vehicle.

## Back-of-Cab Grab Handles, Steps, and Deck Plate

When trailer air and electrical connections cannot be coupled from the ground, Federal Motor Carrier

# Vehicle Access and Features

Safety Regulations require commercial carriers to provide back-of-cab access (**Fig. 3.8**).



**Fig. 3.8, Back-of-Cab Access**

A grab handle is mounted either on the exhaust shield, the cab, or the sleeper. Steps are mounted on the fuel tank, battery box, or frame; depending on the available space. When an optional deck plate is included, it is mounted across the top of the frame rails.

## **WARNING**

**Wet or dirty shoes, steps, or grab rails greatly increase the chance of slipping or falling. If your shoes or the contact areas are wet or dirty, be especially careful when entering or exiting the vehicle, or back-of-cab access.**

**Always maintain three-point contact with the vehicle, when accessing the back of the cab. Three-point contact means both feet and one hand, or both hands and one foot.**

**When steps are mounted on battery box covers, make sure that the cover is latched and secure, before using the steps.**

**Do not step on the fuel tank, battery box, frame, etc., unless adequate slip resistant surfaces and handholds are provided.**

**Do not jump from the vehicle.**

## Accessing Back-of-Cab Area

When climbing onto the deck plate, use the grab handle and access steps as follows:

1. Grasp the grab handle with both hands. Reach up as far as is comfortable.
2. Place one foot on the bottom step and pull yourself up.
3. Place your other foot on the top step.
4. Move your lower hand to a higher position on the grab handle.
5. Step onto the deck plate.

## Exiting the Back-of-Cab Area

When climbing down from the deck plate, use the grab handle and access steps as follows:

1. Grasp the grab handle with both hands.
2. Step one foot at a time to the top step.
3. Move your upper hand to a lower position on the grab handle.
4. Move one foot to the bottom step.
5. Move your upper hand to a lower position on the grab handle.
6. Step to the ground with your upper foot first.

## Fuse, Relay, and Circuit Breaker Identification

There are two power distribution modules (PDM) in the vehicle. The internal PDM is located below the right-side dash or the passenger-side dash. The external PDM is located under the hood on the front-wall. Refer to **Fig. 3.9** and **Table 3.1** for the internal PDM fuse, relay, and circuit breaker identification. Refer to **Fig. 3.10** and **Table 3.2** for the external PDM fuse, relay, and circuit breaker identification.

Internal PDM Fuse, Relay, and Circuit Breaker Identification			
Pos. No.	Description	Part Number	Rating
1	—	D9ZB-14A094-CA and F6HT-14526-CA	10A



# Vehicle Access and Features

Internal PDM Fuse, Relay, and Circuit Breaker Identification			
Pos. No.	Description	Part Number	Rating
2	Power Door Lock	D9ZB-14A094-CA and F6HT-14526-CA	10A
3	Horn/Buzzer	D9ZB-14A094-CA and F6HT-14526-CA	10A
4	Windshield Washer/Wiper	F6HT-145264-NA and F6HT-14526-NA	11/CB
5	—	D9ZB-14A094-DA and F6HT-14526-DA	15A
6	Air Dryer Heater	D9ZB-14A094-CA and F6HT-14526-CA	10A
7	—	D9ZB-14A094-CA and F6HT-14526-CA	10A
8	Axle Shift	D9ZB-14A094-DA and F6HT-14526-DA	15A
9	—	D9ZB-14A094-CA and F6HT-14526-CA	10A
10	Backup Lamp	D9ZB-14A094-CA and F6HT-14526-CA	10A
11	Open	D9ZB-14A094-CA and F6HT-14526-CA	10A
12	—	D9ZB-14A094-CA and F6HT-14526-CA	10A
13	—	D9ZB-14A094-CA and F6HT-14526-CA	10A
14	—	D9ZB-14A094-CA and F6HT-14526-CA	10A
15	Radio System	D9ZB-14A094-EA and F6HT-14526-EA	20A
16	Radio System	D9ZB-14A094-CA and F6HT-14526-CA	10A
17	Mirror, Heated, Power	D9ZB-14A094-FA and F6HT-14526-FA	25A
18	Accessory Supply	D9ZB-14A094-DA and F6HT-14526-DA	15A
19	—	D9ZB-14A094-BA and F6HT-14526-BA	5A
20	—	D9ZB-14A094-DA and F6HT-14526-DA	15A
21	—	D9ZB-14A094-CA and F6HT-14526-CA	10A
22	Ignition Run	D9ZB-14A094-CA and F6HT-14526-CA	10A
23	—	D9ZB-14A094-DA and F6HT-14526-DA	15A
24	CB Radio Post	D9ZB-14A094-DA and F6HT-14526-DA	15A

Internal PDM Fuse, Relay, and Circuit Breaker Identification			
Pos. No.	Description	Part Number	Rating
25	Start, Ignition	D9ZB-14A094-FA and F6HT-14526-FA	25A
26	ABS Hydraulic Pump	D9ZB-14A094-CA and F6HT-14526-CA	10A
27	Open	—	—
28	Open	—	—
29	Open	—	—
30	Open	—	—
31	Interior Light	D9ZB-14A094-DA and F6HT-14526-DA	15A
32	Marker Clearance Lamp	D9ZB-14A094-DA and F6HT-14526-DA	15A
33	Cluster Diagram Connector	D9ZB-14A094-DA and F6HT-14526-DA	15A
34	Left Side Power Window	F6HT-14526-MA and F6HT-14526-MA	18A/CB
35	Right Side Power Window	F6HT-14526-MA and F6HT-14526-MA	18A/CB
36	Utility/Trailer Lamp	—	—
37	Head Lamp	D9ZB-14A094-DA and F6HT-14526-DA	15A
38	Open	D9ZB-14A094-CA and F6HT-14526-CA	—
39	Fog/Road Lamp	D9ZB-14A094-CA and F6HT-14526-CA	10A
40	Open	—	—
41	Open	—	—
42	Stop Lamp/Hazard Warning Lamp	D9ZB-14A094-GA and F6HT-14526-GA	30A
43	Engine	D9ZB-14A094-CA and F6HT-14526-CA	10A
44	—	D9ZB-14A094-CA and F6HT-14526-CA	—
45	ABS	D9ZB-14A094-BA and F6HT-14526-AA	5A
46	—	D9ZB-14A094-CA and F6HT-14526-CA	10A
47	ABS	D9ZB-14A094-BA and F6HT-14526-AA	5A
48	—	D9ZB-14A094-BA and F6HT-14526-BA	—
R1	Right Side Power Window Relay	23-11276-011	—
R2	Left Side Power Window Relay	23-11276-011	—
R3	2-Speed Axle Relay	23-11276-011	—

# Vehicle Access and Features

Internal PDM Fuse, Relay, and Circuit Breaker Identification			
Pos. No.	Description	Part Number	Rating
R4	Ignition Run Relay	23-11276-011	—
R5	Ignition Run/ Accessory Relay	23-11276-011	—
R6	Ignition Run Relay	23-11276-011	—
R7	Fog/Road Lamp	23-11276-011	—
R8	HVAC Blower	—	—
R9	Hazard Warning Lamps	—	—
R10	Open	—	—
R11	Windshield Wiper/ Washer	23-11276-011	—
R12	ABS Power	23-11276-011	—
R13	Transmission	680 545 00 05	—
R14	Brake Cut Out	680 545 00 05	—

Internal PDM Fuse, Relay, and Circuit Breaker Identification			
Pos. No.	Description	Part Number	Rating
R15	Open	—	—
R16	Open	—	—
R17	Hydraulic Brake Pump	680 545 00 05	—
R18	Engine Brake	680 545 00 05	—
R19	ABS Lamp	680 545 00 05	—
R20	2-Speed Axle, MBE	680 545 00 05	—
R21	Electronic Engine Service Brake	680 545 00 05	—
R22	Trans ABS	680 545 00 05	—

**Table 3.1, Internal PDM Fuse, Relay, and Circuit Breaker Identification**

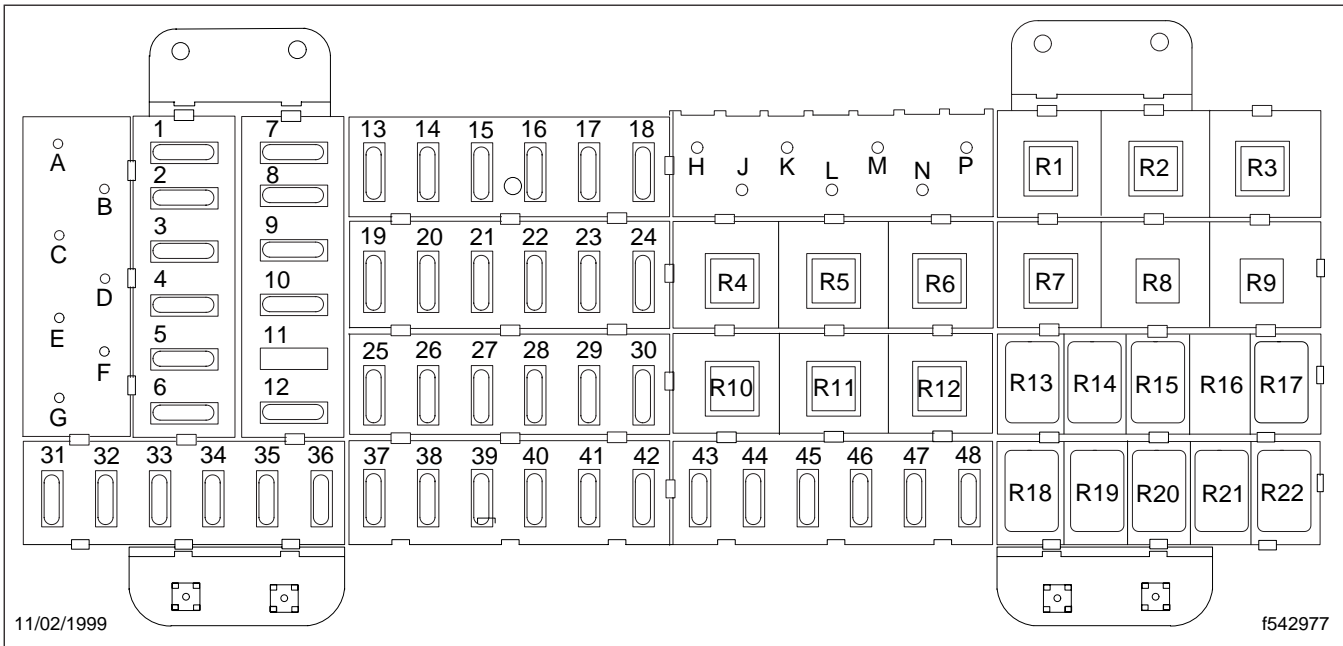
External PDM Fuse, Relay, and Circuit Breaker Identification			
Pos.	Description	Part Number	Rating
R-A	Fuel Heater Relay (optional)	F0AB-14B192-AA	—
R-B	Tail/Brake Lamp Relay (body builder)	F0AB-14B192-AA	—
R-C	Marker Lamp Relay (body builder)	F0AB-14B192-AA	—
R-D	Transmission, Backup Light Relay	F0AB-14B192-AA	—
R-E	Trailer ABS ECU Constant Relay	F80B-14B192-AA	—
R-F	Transmission Neutral Relay	F0AB-14B192-AA	—
R-G	Not Used	—	—
R-H	Not Used	—	—
R-J	Not Used	—	—
R-K	Not Used	—	—
R-L	Not Used	—	—
R-M	Not Used	—	—
R-N	Trailer Left-Turn Relay	F0AB-14B192-AA	—
R-P	Trailer Right-Turn Relay	F0AB-14B192-AA	—
R-R	Trailer Park Lamp Relay	F0AB-14B192-AA	—
R-U	Trailer Marker Lamp Relay	F0AB-14B192-AA	—
R-V	Trailer Brake Lamp Relay	F80B-14B192-AA	—
R-W	Not Used	—	—
A	Power to R-A Fuel Heater (optional)	E97B-14A094-BA and F6HT-14526-JA	40A Fuse 40A CB
B	Feed F1, F2 (PDM electrical center)	E97B-14A094-AA and F6HT-14526-LA	30A Fuse 30A CB
C	Feed to R-B, R-C (body builder)	E97B-14A094-BA and F6HT-14526-JA	40A Fuse 40A CB
D	Feed F13, F14, F15 (PDM electrical center)	E97B-14A094-BA and F6HT-14526-JA	40A Fuse 40A CB
E	Power to R-2 (PDM electrical center) Left Door	E97B-14A094-BA and F6HT-14526-JA	40A Fuse 40A CB
F	Feed F36 (PDM electrical center)	E97B-14A094-BA and F6HT-14526-JA	40A Fuse 40A CB
G	Power to R-8 (PDM electrical center) HVAC Blower Motor	E97B-14A094-BA and F6HT-14526-JA	40A Fuse 40A CB
H	Power to R-6 (PDM electrical center) Ignition Run	E97B-14A094-BA and F6HT-14526-JA	40A Fuse 40A CB

# Vehicle Access and Features

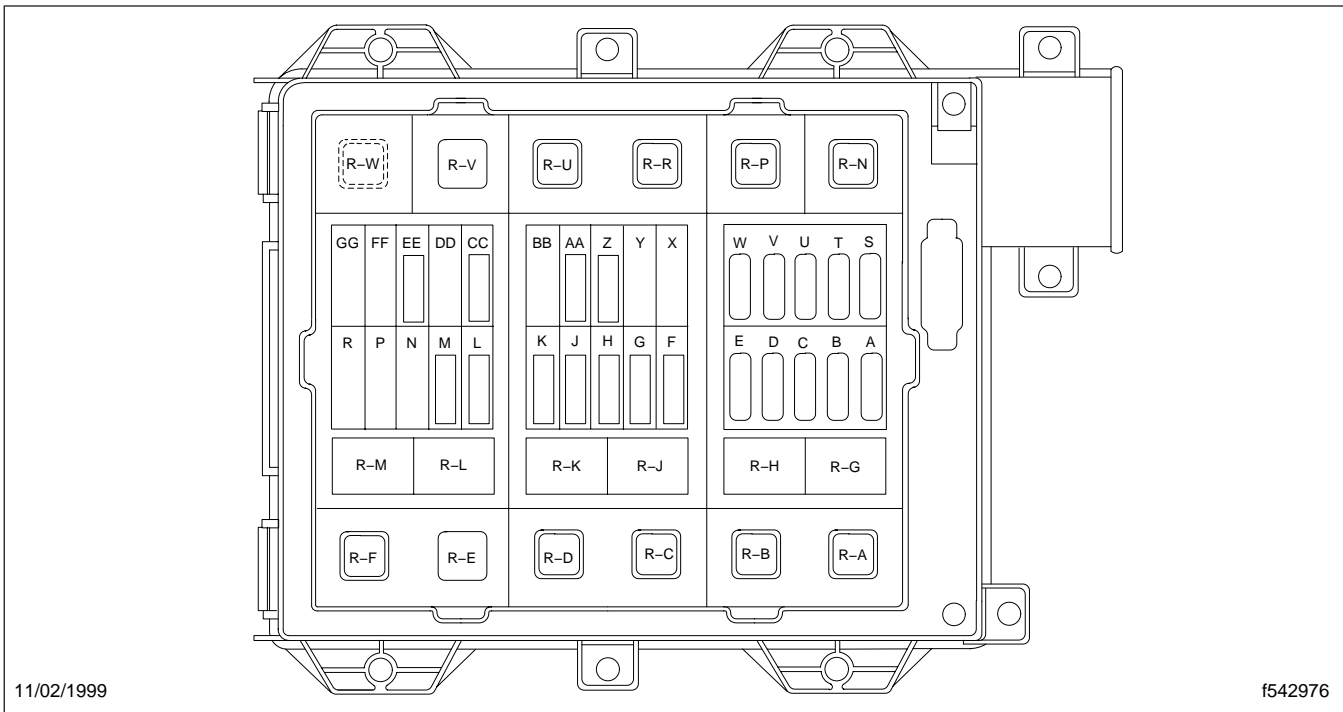
External PDM Fuse, Relay, and Circuit Breaker Identification			
Pos.	Description	Part Number	Rating
J	Ignition to R-5 (PDM electrical center)	E97B-14A094-DA	60A Fuse 60A CB
K	Feed F31, F32, F33 (PDM electrical center)	E97B-14A094-BA and F6HT-14526-JA	40A Fuse 40A CB
L	Feed F37 (PDM electrical center) Head Lamps	E97B-14A094-BA and F6HT-14526-JA	40A Fuse 40A CB
M	Feed F26 (PDM electrical center) ABS Power	E97B-14A094-BA and F6HT-14526-JA	40A Fuse 40A CB
N	Open	—	—
P	Open	—	—
R	Open	—	—
S	Feed F3, F4 (PDM electrical center) Windshield Wipers	E97B-14A094-BA and F6HT-14526-JA	40A Fuse 40A CB
T	Power to R-N, R-P Trailer Left and Right Turn Signals	E97B-14A094-BA and F6HT-14526-JA	40A Fuse 40A CB
U	Feed F23, F24 (PDM electrical center) CB Radio	E97B-14A094-BA and F6HT-14526-JA	40A Fuse 40A CB
V	Power to R-1 (PDM electrical center) Right Door	E97B-14A094-BA and F6HT-14526-JA	40A Fuse 40A CB
W	Power to R-R, R-U Trailer Park/Marker	E97B-14A094-BA and F6HT-14526-JA	40A Fuse 40A CB
X	Open	—	30A Fuse 30A CB
Y	Open	—	30A Fuse 30A CB
Z	Feed F42 (PDM Electrical Center) Brake Lamp/Flash	E97B-14A094-BA and F6HT-14526-JA	40A Fuse 40A CB
AA	Feed PDM Electrical Center (A) Custom Access Panel	E97B-14A094-BA and F6HT-14526-JA	40A Fuse 40A CB
BB	Open	—	30A Fuse 30A CB
CC	Power to R-V Trailer Brake Lamp	E97B-14A094-BA and F6HT-14526-JA	40A Fuse 40A CB
DD	Open	—	—
EE	Power to R-E Trailer	E97B-14A094-BA and F6HT-14526-JA	40A Fuse 40A CB
FF	Open	—	—
GG	Open	—	—

**Table 3.2, External PDM Fuse, Relay, and Circuit Breaker Identification**

# Vehicle Access and Features



**Fig. 3.9, Internal PDM Fuse, Relay, and Circuit Breaker Panel**



**Fig. 3.10, External PDM Fuse, Relay, and Circuit Breaker Panel**

# 4

## Heater and Air Conditioner

---

HVAC General Information .....	4.1
Defogging and Defrosting Using Fresh Air .....	4.1
Heating .....	4.2
Air Conditioning, Optional .....	4.2
Fresh Air .....	4.2

# Heater and Air Conditioner

## HVAC General Information

A dash-mounted climate control panel (Fig. 4.1 or Fig. 4.2) allows you to control all of the heating, air conditioning, defrosting, and ventilating functions.

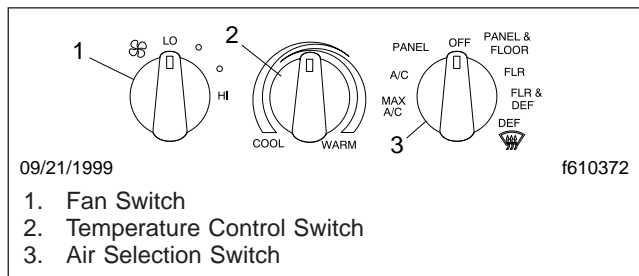


Fig. 4.1, Climate Control Panel With Air Conditioning

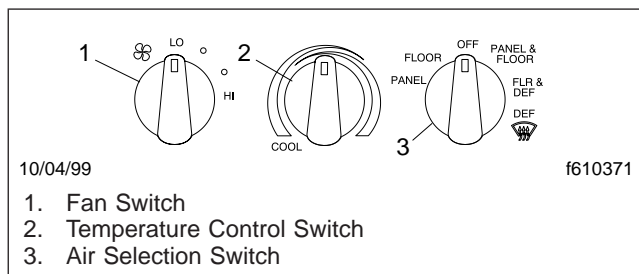


Fig. 4.2, Climate Control Panel Without Air Conditioning

A four-speed fan forces fresh or recirculated air through the air outlets at the windshield, door windows, dash panel, and cab floor.

A temperature control switch is used to select the desired temperature. Turn the switch counterclockwise for cool air, or clockwise for warm air.

An air selection switch controls the direction of warm or cool air either through the dash panel louvers, the dash panel louvers and floor outlets, the floor outlets, the floor and defrost (windshield) outlets, or the defrost outlets.

The dash panel louvers can be adjusted left and right, and up and down. Close the louver by moving the control toward the solid circle; open the louver by moving the control toward the open circle (Fig. 4.3).

Fresh air is forced through the air outlets when the air selection switch is in the A/C (air conditioning), PANEL, PANEL & FLOOR, FLR (floor), FLR & DEF (defrost), and DEF positions. Recirculated air is forced through the air outlets when the air selection

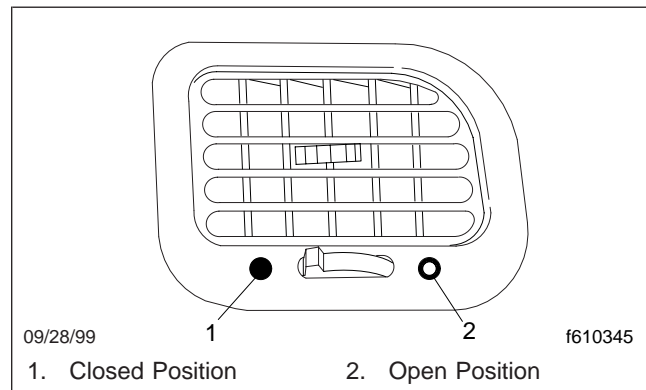


Fig. 4.3, Dash Panel Louver

switch is in the MAX A/C (maximum air conditioning) position. Dusty or smoky outside air is prevented from being drawn inside the cab when the air selection switch is in the OFF position.

**IMPORTANT:** To prevent the buildup of fumes or odors (for example from smoking) and to prevent oxygen depletion inside the cab, do *not* operate the air conditioning system in the MAX A/C mode for more than 20 minutes.

**NOTE:** An engine heater supply gate valve is optional on the Acterra. Shutting off the heater supply gate valve limits the ability to control the air conditioning temperature in the cab. With the valve shut off, warm coolant is no longer available from the engine and the controls on the climate control panel can't be used to change the air temperature.

## Defogging and Defrosting Using Fresh Air

1. Turn the temperature control switch all the way clockwise for warm air, and turn the fan switch to LO before starting the engine.
2. Remove any ice or snow from the outside of the windshield, door windows, and fresh air inlet grille.
3. With the engine at operating temperature, turn the fan switch to the highest speed. Leave it in this position for 30 seconds. This will clear the system of moist air.

4. Move the air selection switch to the defrost (DEF) position. In this position warm, dry air is directed to the windshield.

NOTE: If your vehicle is equipped with air conditioning, the air conditioner automatically comes on in the defrost mode. Operating in this mode dries the air.

## Heating

1. With the engine at operating temperature, move the temperature control switch all the way clockwise for heat.
2. Turn on the fan switch to the desired speed.
3. Move the air selection switch to the desired setting.

IMPORTANT: If the windows start to fog, move the air selection switch to defrost (DEF) and make sure the fan is on.

NOTE: In mild weather the fan switch can be kept in the LO position since forward motion of the vehicle will provide airflow through the heater.

4. When a comfortable temperature has been reached, adjust the fan switch setting and temperature control switch as needed to maintain the temperature.

## Air Conditioning, Optional

IMPORTANT: Operate the air conditioner at least five minutes each month, even during cool weather. This helps prevent drying and cracking of tubing seals, reducing refrigerant leaks in the system. Operate the air conditioner only after the engine compartment is warm, and the interior of the cab is 70°F (21°C) or higher. During cold weather, the heater can be operated at the same time to prevent discomfort.

1. If the cab is hot inside, temporarily open the windows to let the hot air out.
2. Move the air selection switch to a non-air conditioning panel position and turn the fan switch to LO before starting the engine.
3. Start the engine.

4. Move the air selection switch to either one of the air conditioning settings. With the switch at the A/C setting, fresh air is drawn into the cab. With the switch at MAX A/C, the air inside the cab is recirculated. A recirculated air (RECIRC AIR) indicator on the dash message center illuminates when the air inside the cab is recirculated.

IMPORTANT: To prevent the buildup of fumes or odors (for example from smoking) and to prevent oxygen depletion inside the cab, do *not* operate the air conditioning system in the MAX A/C mode for more than 20 minutes.

5. Move the temperature control switch counterclockwise for cool air. In this position, no heat is given off by the heater.
6. Turn the fan switch to the highest speed.
7. As soon as cool air is flowing from the dash panel louvers, close the windows. Adjust the fan switch setting as desired.
8. If the air from the outlets is too cold, move the temperature control switch clockwise for warmer air flow.

IMPORTANT: If the outside air is dusty or smoky, set the air selection switch to MAX A/C and keep the windows and vent closed to prevent drawing in dust or smoke. The air selection switch can also be set to OFF to prevent drawing in dust or smoke.

## Fresh Air

1. Move the air selection switch to the desired position.
2. Move the temperature control switch counterclockwise for no heating, or move it clockwise for heat.
3. Set the fan switch at the desired speed.

# 5

## Seats and Seat Belts

---

Seats .....	5.1
Seat Belts and Tether Belts .....	5.5



# Seats and Seat Belts

## Seats

### General Information

Unless otherwise noted, all seat adjustments should be made while seated and before the engine is started.



Keep hands, tools, and other objects away from the scissor points under the seats. Failure to do so could cause personal injury.

### Seat Adjustment

The following is a description of adjustments that can be made to various Sterling-installed seats. Not all seats have all of the adjustments listed below. See [Fig. 5.1](#) for illustrations of the seat adjustments.

1. Back Cushion Tilt: This adjustment tilts the back cushion forward or backward.
2. Lumbar Support: Lumbar support changes the shape of the back of the seat to give more or less support to the occupant's lumbar (lower back) area. This adjustment is either mechanical or air controlled depending on the type of seat.
3. Isolator: This feature (also referred to as back-slap isolator or Chugger-Snubber<sup>®</sup>) reduces the amount of road shock by isolating the occupant from the motion of the vehicle and allowing the upper seat to move in a simple pendulum motion. A lockout feature is used when the isolator is not desired.
4. Height Adjustment: The entire seat moves up or down when adjusting the height. The adjustment is either manually controlled or air controlled depending on the type of seat.
5. Bottom Cushion Angle or Fore and Aft Bottom Cushion Height: This feature lets the occupant raise or lower the front or back of the bottom cushion. This adjustment is easier to perform when all weight is removed from the seat.

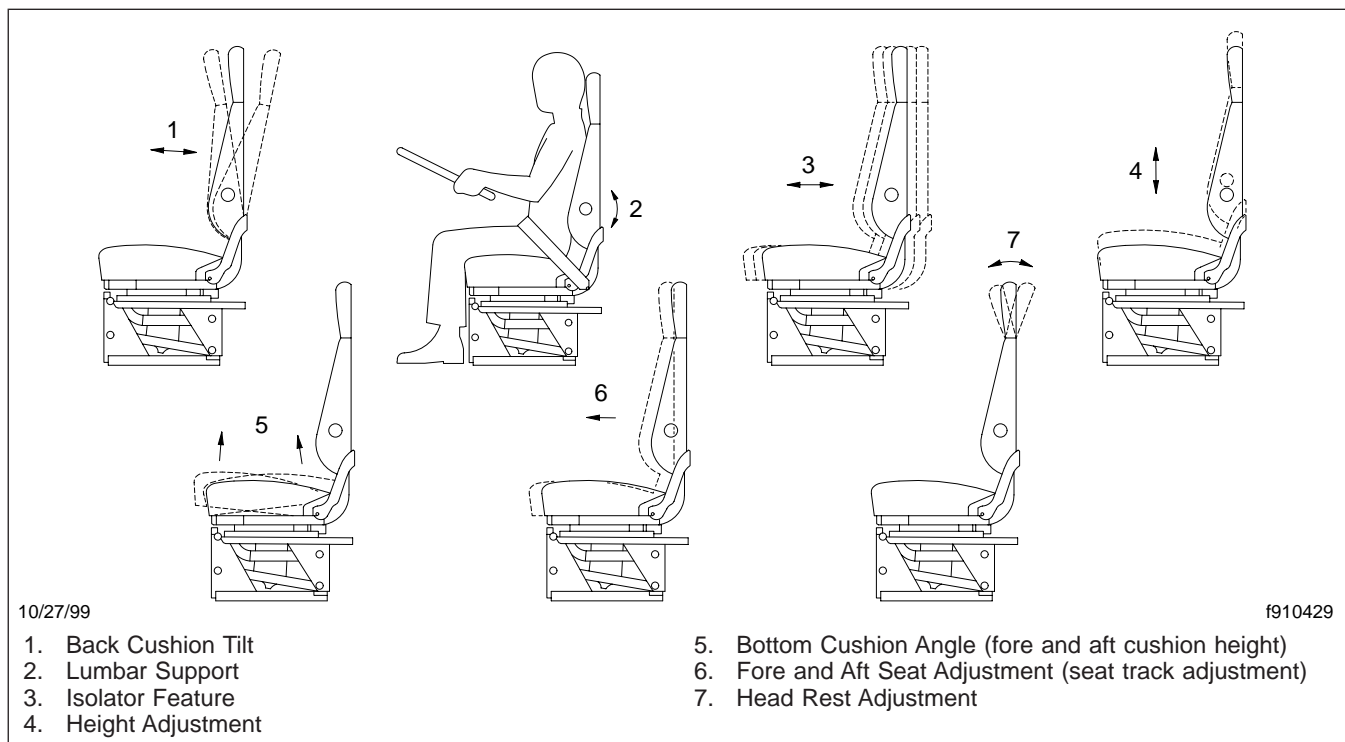
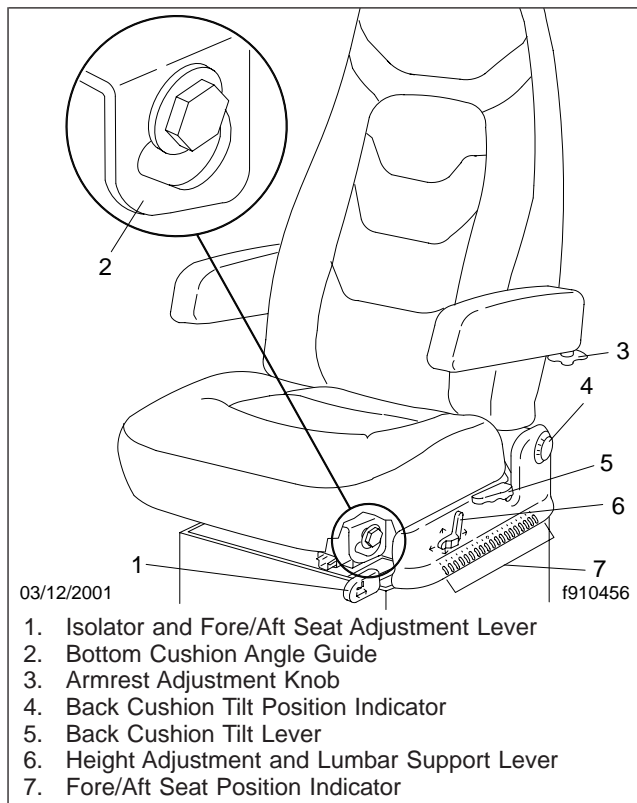


Fig. 5.1, Seat Adjustments

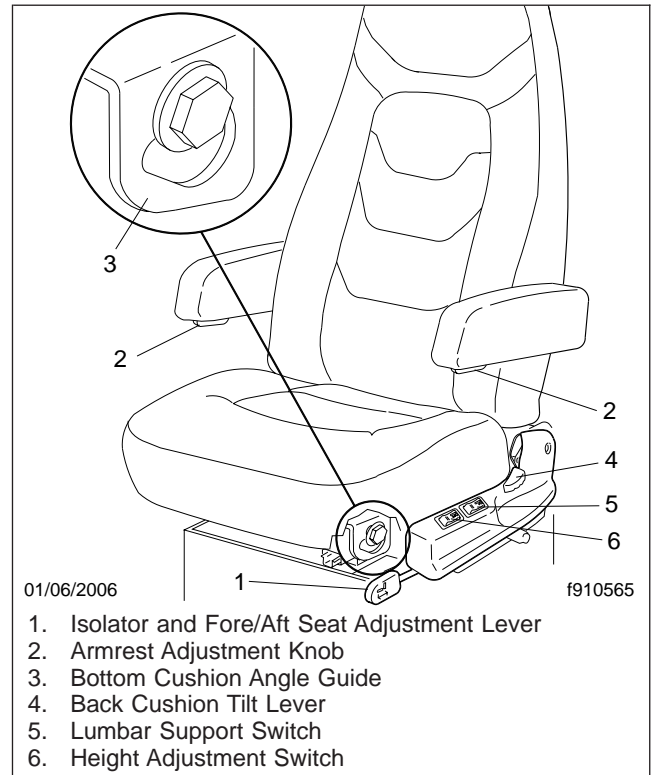
6. Fore and Aft Seat or Seat Track Adjustment: The entire seat moves forward or backward when this adjustment is made.
7. Head Rest Adjustment: When this adjustment is made, the angle of the head rest changes to provide support to the head.
8. Weight Adjustment: On seats with weight adjustment, the feature is fully automatic. When you sit on the seat, a leveling valve places you in the center of the ride zone. Additional adjustments are possible by using the height adjustment feature.

## EzyRider® Seat

For seat adjustment controls on vehicles built before November 28, 2005, see [Fig. 5.2](#). For seat adjustment controls on vehicles built on or after November 28, 2005, see [Fig. 5.3](#).



**Fig. 5.2, EzyRider Seat Adjustment Controls (Vehicles Built Before November 28, 2005)**



**Fig. 5.3, EzyRider Seat Adjustment Controls (Vehicles Built on or After November 28, 2005)**

### Back Cushion Tilt

To tilt the back cushion, raise the back cushion tilt lever and lean forward or backward. Release the lever to lock the cushion in place.

### Lumbar Support

To adjust the amount of support for your lower back, use the lumbar support switch or lever on the side of the seat.

### Isolator

To engage the isolator, push in on the isolator lever. To lock out the isolator, pull the isolator lever out to the first stop.

### Fore and Aft Seat Adjustment

Pull the fore and aft seat adjustment lever out to the second stop and slide the seat forward or backward to the desired position.

# Seats and Seat Belts

## Height Adjustment

To raise or lower the seat, use the height adjustment switch or lever on the side of the seat.

## Bottom Cushion Angle

To adjust the bottom cushion angle, pull the bottom cushion up and forward or down and back. The bottom cushion angle is controlled by the guides on each side of the seat.

## Seat Position Indicators

Seats installed in vehicles built before November 28, 2005 are equipped with seat position indicators. A back cushion tilt position indicator and a fore/aft seat position indicator allow the driver to see where the seat is adjusted within the adjustment ranges.

## Armrest Angle (optional armrests)

To adjust the vertical angle of the armrest, turn the adjustment knob on the underside of the armrest.

## National Nonsuspended Seat

See [Fig. 5.4](#) for seat adjustment controls.

### Back Cushion Tilt

To tilt the back cushion, turn the back cushion tilt knob and lean forward or backward.

### Fore and Aft Seat Adjustment

To adjust the fore and aft position of the entire seat, move the fore and aft seat adjustment lever to the left and slide the seat forward or backward to the desired position.

### Fore and Aft Bottom Cushion Adjustment

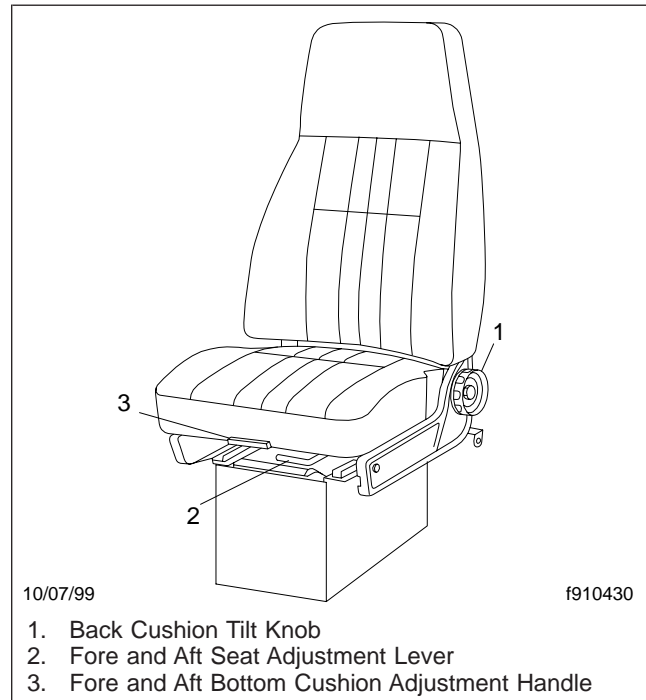
To adjust the fore and aft position of the bottom cushion only, pull the fore and aft bottom cushion adjustment handle out and slide the bottom cushion forward or backward to the desired position.

## National 2000 Series Seat

See [Fig. 5.5](#) for seat adjustment controls.

### Back Cushion Tilt

To tilt the back cushion, turn the back cushion tilt knob until the desired position is reached.



**Fig. 5.4, National Nonsuspended Seat Adjustment Controls**

## Height Adjustment

To raise or lower the height of the seat, use the height adjustment switch on the side of the seat.

## Fore and Aft Seat Adjustment

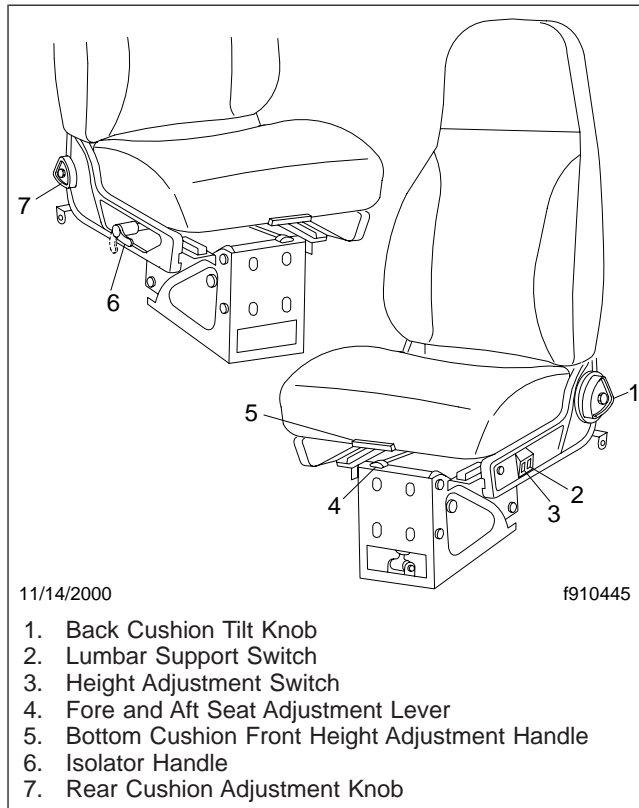
To adjust the fore and aft position of the entire seat, move the fore and aft seat adjustment lever to the left and slide the seat forward or backward to the desired position. Move the lever back to its original position to lock the seat in place.

## Rear Cushion Adjustment

To adjust the height of the rear of the seat cushion, remove your weight from the seat and turn the rear cushion adjustment knob to one of three positions.

## Isolator

Also called a Chugger Snubber®, the isolator reduces the amount of road shock by isolating the occupant from the motion of the vehicle and allowing the seat to move in a simple pendulum motion. To use the



**Fig. 5.5, National 2000 Series Seat Adjustment Controls**

isolator feature, turn the isolator handle to the horizontal position. Turn the isolator handle down when the isolator feature is not desired.

### Lumbar Support

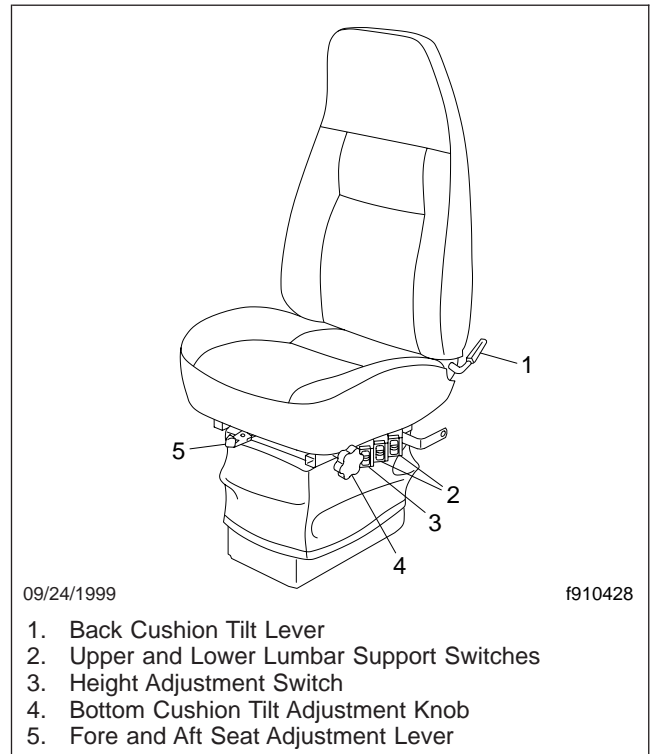
To adjust the lumbar support, use the lumbar support switch on the side of the seat to give more or less support to your lower back.

### Bottom Cushion Front Height

To adjust the height of the front of the bottom cushion, lift the bottom cushion front height adjustment handle, and pull forward or push back to the desired setting.

## Bostrom Talladega™ 915 Seat

See [Fig. 5.6](#) for seat adjustment controls.



**Fig. 5.6, Bostrom Talladega 915 Seat Adjustment Controls**

### Back Cushion Tilt

To tilt the back cushion, lean forward slightly to remove pressure from the cushion and hold the back cushion tilt lever down. Lean backward slowly to the desired position and release the lever to lock the cushion in place.

### Height Adjustment

To raise the seat, push up on the height adjustment switch. To lower the seat, push down on the height adjustment switch.

### Fore and Aft Seat Adjustment

Move the fore and aft seat adjustment lever to the side to adjust the seat to the desired fore-aft position. Move the lever back to its original position to lock the fore-aft position.

### Bottom Cushion Tilt Adjustment

Turn the bottom cushion tilt adjustment knob to increase or decrease the bottom cushion tilt.

# Seats and Seat Belts

---

## Lumbar Support

For seats with air lumbar support, use the upper and lower lumbar support switches to adjust the top lumbar and bottom lumbar supports.

## Two-Passenger Bench Seat

The two-passenger bench seat is stationary. The bottom seat cushion lifts up to access an additional storage area under the seat.

## Seat Belts and Tether Belts

### General Information

Seat belt assemblies are designed to secure persons in the vehicle to help lessen the chance of injury or the amount of injury resulting from accidents or sudden stops. For this reason, Sterling Truck Corporation urges the driver and *all* passengers, regardless of age or physical condition, to use seat belts when riding in the vehicle.

Seat belt assemblies in the vehicle meet Federal Motor Vehicle Safety Standard 209, "Type 1" and "Type 2" requirements. They are recommended for all persons weighing over 50 pounds (23 kg).

A child restraint system should also be provided for each child weighing 50 pounds (23 kg) or less. It should meet the requirements of Federal Motor Vehicle Safety Standard 213, "Child Restraint Systems." When providing such a restraint system, carefully read and follow all instructions pertaining to installation and usage for the child. Make certain the child remains in the restraint system at all times when the vehicle is in motion.

In addition to seat belt assemblies, tether belts are installed on suspension-type seats. Tether belts help secure the seat to the floor and are intended to restrain the seat and seat belt in case of an accident or sudden stop.

**IMPORTANT:** Seat belts have a finite life which may be much shorter than the life of the vehicle. Regular inspections and replacement as needed are the only assurance of adequate seat belt security over the life of the vehicle.

See [Chapter 11](#) for the seat belt inspection procedure.

## Seat Belt Operation

### Three-Point Seat Belt With Komfort® Latch

While your vehicle is in motion, the combination lap and shoulder belt adjusts to your movement. However, if you brake hard, corner hard or if your vehicle receives an impact of 5 mph (8 km/h) or more, the lap and shoulder belt locks and prevents you from moving.

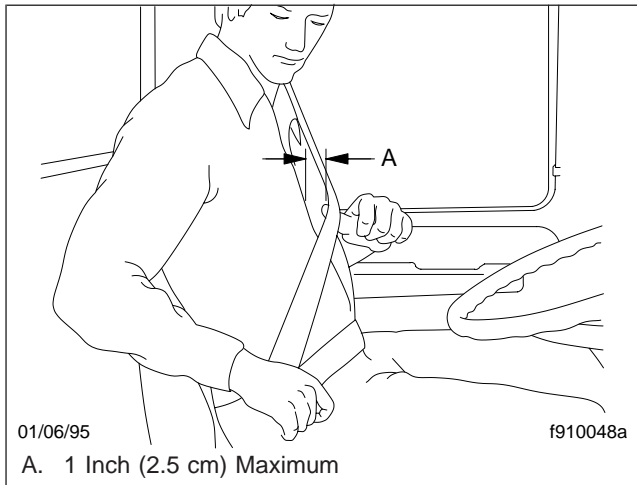


**Wear three-point seat belts only as described below. Three-point seat belts are designed to be worn by one person at a time. In case of an accident or sudden stop, personal injury or death could result from misuse.**

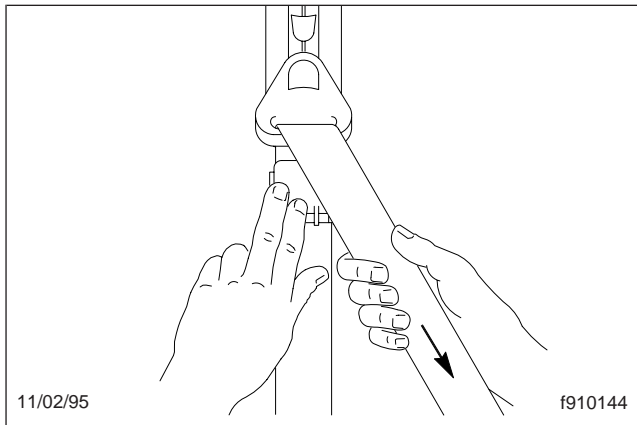


**Fasten the seat belts before driving. Fastening a three-point seat belt while driving creates a hazard.**

1. Pull the lap-shoulder portion of the belt from the retractor so that the shoulder portion of the belt crosses your shoulder and chest. Insert the belt tongue into the proper buckle until you hear a snap and feel it latch.
2. Tighten the lap portion of the belt, pull up on the shoulder piece until it fits you snugly. The belt should rest as low on your hips as possible.
3. If desired, engage the Komfort latch as follows:  
Pull on the shoulder strap to lessen the pressure of the strap on your shoulder and chest. Allow no more than one inch (2.5 cm) of slack between your chest and the shoulder harness. See [Fig. 5.7](#). More slack can significantly reduce the seat belt's effectiveness in an accident or a sudden stop. While holding the belt slack, press the Komfort latch lever up, clamping the belt's webbing. See [Fig. 5.8](#).
4. To unbuckle the three-point seat belt, push the button on the buckle as shown in [Fig. 5.9](#). If the Komfort latch was used, release it by giving the shoulder belt a quick tug. If you lean forward against the shoulder belt, the Komfort latch will automatically release and will need to be reset.



**Fig. 5.7, Adjusting Shoulder Harness Clearance**

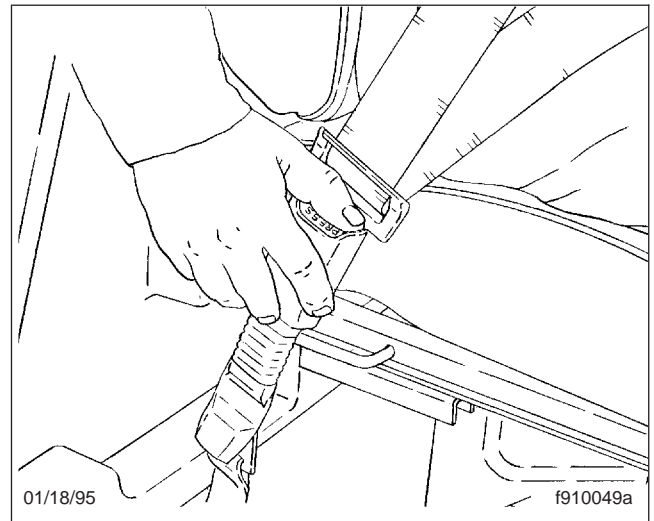


**Fig. 5.8, Locking the Komfort Latch**

**NOTE:** The Komfort Latch does not have to be released in an emergency situation. The Komfort Latch will release by itself under rough road or other abnormal conditions. Make sure the three-point seat belt is completely retracted when it is not in use.

## Lap Belt Without a Retractor

The center lap belt on a two-passenger seat does not have a retractor and therefore should be shortened and fastened when being used. To lengthen the belt, tip the belt tongue at a right angle to the belt and pull the belt over your lap until the tongue reaches the buckle.



**Fig. 5.9, Releasing the Three-Point Seat Belt**

1. Pull the belt across your hips and insert the tongue into the correct buckle on your seat until you hear a snap and feel it lock.
2. Make sure the buckle is securely fastened.
3. Adjust the belt so that it fits snugly around your hips. If you need to lengthen the belt, unfasten it and repeat the previous steps. If you need to shorten the belt, pull on the loose end of the belt.

# 6

## Steering and Brake Systems

---

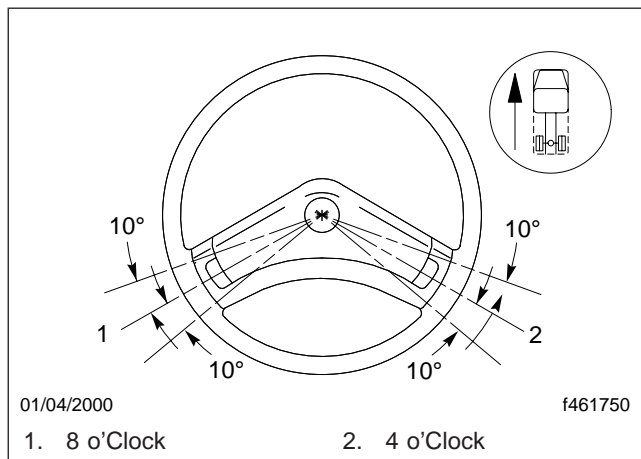
Steering System .....	6.1
Air Brake System .....	6.1
Hydraulic Brake System .....	6.5

# Steering and Brake Systems

## Steering System

### General Information

When there is no load on the vehicle and the front tires are pointed straight ahead, the steering wheel spokes should be at the 4 o'clock and 8 o'clock positions, or within 10 degrees of these positions. See **Fig. 6.1**. For steering wheel adjustment procedures, see **Group 46** of the *Acterra® Workshop Manual*.



**Fig. 6.1, Steering Wheel Centered**

### Power Steering System

The power steering system consists of a steering gear (which includes a manual steering mechanism, a hydraulic control valve, and a hydraulic power cylinder), hydraulic hoses, power steering pump, power steering reservoir, and other components. Some models are also equipped with a separate hydraulic power cylinder on the right side of the front axle. The power steering pump, driven by the engine, provides the power assist for the steering system. If the engine is not running, there is no power assist.

If the power-assist feature does not work due to hydraulic fluid loss, steering pump damage, or some other cause, bring the vehicle to a safe stop. Do not drive the vehicle until the cause of the problem is corrected.

### **! WARNING**

**Driving the vehicle without the power-assist feature of the steering system requires much greater effort, especially in sharp turns or at low speeds,**

**which could result in an accident and possible injury.**

Drivers should use the power available with a power steering system carefully. If the front tires become lodged in a deep chuckhole or rut, drive the vehicle out instead of using the steering system to lift the tires from the hole. Also, avoid turning the tires when they are against a curb as this places a heavy load on steering components and could damage them.

## Air Brake System

### General Information

A dual air brake system operates two independent air brake systems through one set of brake controls. Each system has its own reservoir, plumbing, and brake chambers. The primary air system operates the service brakes on the rear axles; the secondary air system operates the service brakes on the front axle. Either or both the primary and secondary systems can operate the trailer brakes.

### **! WARNING**

**Do not operate the vehicle with the front brakes backed off or disconnected. Backing off or disconnecting the front brakes will not improve vehicle handling and may lead to loss of vehicle control resulting in property damage or personal injury.**

If the primary air system loses pressure, the rear service brakes will not work but the secondary air system will continue to operate the front axle and trailer brakes.

If the secondary air system loses air pressure, the front brakes will not work but the primary air system will continue to operate the rear service brakes and trailer brakes.

**IMPORTANT:** When air pressure is lost in one of the air systems, the air compressor will operate but will not replenish the air supply in the system that is not leaking. There will only be enough air in the non-leaking system to get the vehicle stopped. Therefore, it is important to bring the vehicle to a safe stop as soon as possible. Do not attempt to drive the vehicle again until the problem is corrected.



# Steering and Brake Systems

Trucks are equipped with spring brake modulation. If an air pressure loss occurs in the primary air system, the rear spring brakes will be modulated (applied and released) according to how hard the brake pedal is being pushed. There will only be enough air in the secondary system for two to four brake applications, then the park brake valve will pop out and lock the brakes.

Before driving your vehicle, allow time for the air compressor to build up a minimum pressure of 95 psi (655 kPa) in both air systems. Monitor the air pressure system by observing the primary and secondary air pressure gauges and the low air pressure warning light and buzzer. The warning light and buzzer shut off when air pressure in both systems reaches 64 to 76 psi (441 to 524 kPa).

The low air pressure warning light and buzzer come on if air pressure drops below 64 to 76 psi (441 to 524 kPa) in either system. If this happens, check the air system pressure gauges to determine which system has low pressure. Although the service brakes will still slow the vehicle, one set of the service brakes will not be operating and the vehicle will require a longer distance to stop. Bring the vehicle to a safe stop and have the air system repaired before continuing.

If a tractor-trailer loses pressure in both the primary and secondary air systems, the trailer service brakes or spring parking brakes will automatically activate when the air pressure drops below 35 to 45 psi (241 to 310 kPa). The tractor spring parking brakes will automatically activate when the air pressure drops below 20 to 30 psi (138 to 207 kPa). On trucks, spring parking brakes will come on when the air pressure drops below 20 to 30 psi (138 to 207 kPa). The activation is gradual but irreversible. Do not wait for automatic activation of the brakes. When the low air pressure warning light and buzzer first come on, immediately bring the vehicle to a safe stop. Correct the cause of the air loss before attempting to drive the vehicle again.

## WARNING

**Do not drive the vehicle with the parking brakes caged. If the vehicle is driven with the parking brakes caged, there would be no means of stopping the vehicle if a complete loss of air pressure occurred. This could result in serious personal injury or vehicle damage.**

**IMPORTANT:** Connect to a towing vehicle or chock the tires before caging the spring parking brakes.

**NOTE:** Before a vehicle with insufficient system air pressure can be moved, the spring parking brakes must be released by connecting an external air source at the gladhands, or by manually caging (manually releasing) the parking brake springs.

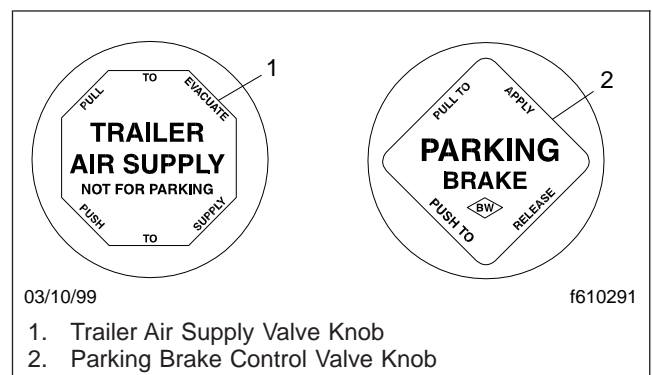
## Operation

Before driving the vehicle, make sure all occupants are wearing seat belts. Secure all loose items in the cab so that they will not fly forward during a full brake application.

In a normal stop, push in the clutch pedal (if the vehicle has one) as the vehicle approaches a halt and shift the transmission to neutral. Set the spring parking brakes after coming to a stop, if the vehicle is to be parked.

**IMPORTANT:** In the event of a total loss of service brakes with full system air pressure, use the parking brake control valve (the yellow knob) to bring the vehicle to a complete stop in the safest location possible.

The yellow diamond-shaped knob (**Fig. 6.2**) on the control panel activates the parking brake valve. Pulling out the knob puts on both the tractor and the trailer spring parking brakes and causes the trailer air supply valve knob to pop out.



**Fig. 6.2, Parking Brake Control Valve and Trailer Air Supply Valve Knobs**

# Steering and Brake Systems

---

Pulling the red octagonal knob (**Fig. 6.2**) on the control panel opens the trailer air supply valve, exhausting the pressurized air from the system and setting the parking spring brakes. When the air hoses from the vehicle are connected to the trailer and the pressure in both air systems reaches at least 65 psi (448 kPa), the red knob must be pushed in. It should remain pushed in to keep the supply valve open, releasing the trailer spring parking brakes and charging the trailer air supply system .

The red knob should be out to block the trailer air supply before disconnecting a trailer. If pressure in both air systems drops to 35 to 45 psi (241 to 310 kPa) the red knob automatically pops out, exhausting the trailer air supply and applying the trailer service or spring parking brakes. Braking increases as pressure falls, until as pressure approaches zero, the brakes are fully set.

## CAUTION

**Do not use the spring parking brakes if the service brakes are hot, such as after descending a steep grade. Also, do not use the spring parking brakes during freezing temperatures if the service brakes are wet. To do so could damage the brakes if hot, or cause them to freeze during cold weather.**

**If the brakes are wet, drive the vehicle in low gear and lightly apply the brakes to heat and dry them. Allow hot brakes to cool before using the spring parking brakes. Always chock the tires.**

If the brakes are wet, drive the vehicle in low gear and lightly apply the brakes to heat and dry them.

Allow hot brakes to cool before using the spring parking brakes.

If the trailer is not equipped with spring parking brakes, pulling out the yellow knob applies the tractor spring parking brakes and the trailer service brakes. When the tractor and trailer parking brakes (or trailer service brakes) are both applied, the trailer brakes can be released by pushing in the red knob, leaving the tractor parking brakes applied. Air pressure in the primary or secondary reservoir must be at least 64 psi (441 kPa) before the tractor spring parking brakes, or the trailer service or spring parking brakes, can be released.

On trailers without spring parking brakes, chock the trailer tires before disconnecting the tractor when

parking just the trailer. When parking a tractor with a trailer, if the trailer is not equipped with spring parking brakes, set the tractor spring parking brakes.

## WARNING

**Do not use the trailer service brakes for parking; they are not designed for this purpose. If air bleeds out of the trailer air tank during parking, the vehicle could roll causing serious personal injury or property damage.**

## Meritor™ WABCO® Antilock Braking System (ABS), Air Brake Systems

The Meritor WABCO Antilock Braking System (ABS) is an electronic wheel speed monitoring and control system that works with the air brake system. ABS passively monitors vehicle wheel speed at all times, but *controls* wheel speed during an emergency or reduced-traction stop. In normal braking applications, the standard air brake system works as they always have and ABS has no active role.

**IMPORTANT:** For proper ABS system operation, use tires of the factory installed size. The sizes of the tires installed during production are programmed into the electronic control unit. Installing different size tires could result in reduced braking ability leading to longer stopping distances.

ABS reads from signal-generating tone wheels and sensors located in the wheel hubs of each sensed axle. The sensors transmit vehicle wheel speed information to an electronic control unit (ECU). The main circuit of the ECU interprets the speed sensor signals and constantly compares wheel speeds, wheel braking rates, and vehicle speed. If it senses a wheel is beginning to lock, the ECU signals the appropriate solenoid control valve to reduce braking in that wheel, preventing a skid. During emergency braking, the solenoid control valve prevents wheel lockup by controlling air pressure in the brake chambers.

The ECU also has a safety circuit which constantly monitors the wheel sensors, solenoid control valves and the electrical circuitry. In a vehicle equipped only with a tractor ABS system, when the ignition switch is turned on the TRACTOR ABS warning light comes on. The warning light goes out only if all of the tractor ABS components are working properly.

## CAUTION

An accumulation of road salt, dirt, or debris on the ABS tone wheels and sensors can cause the ABS warning light to come on. If the ABS light does come on, the tone rings and sensors should be inspected for corrosion and serviced if necessary. The service should include cleaning of the tone rings and sensors. If any tone ring on a vehicle shows severe corrosion, all tone rings on that vehicle should be replaced.

During winter months in areas where corrosive materials are used on the highways, periodically clean the underside of the vehicle, including the tone rings and sensors, to ensure proper ABS function and to protect the components from corrosion. Clean more frequently when unusually corrosive chemicals are being used.

The dash-mounted TRAILER ABS light will operate as follows when a compatible trailer is properly connected to a tractor:

- When the ignition key is turned to the on position, the trailer ABS lamp will illuminate briefly, then turn off.
- If the lamp comes on momentarily during vehicle operation then shuts off, a fault was detected and corrected.
- If the lamp comes on and stays on during vehicle operation, there is a problem with the trailer ABS. Repair the trailer ABS system immediately to ensure full antilock braking capability.

The Trailer ABS lamp will not light up unless a compatible trailer is connected to the tractor.

**IMPORTANT:** If a compatible trailer is connected and the lamp does not flash on briefly when the ignition key is turned on, it is possible that the lamp is burnt out.

Automatic Traction Control is an option available on ABS-equipped vehicles with air brake systems. It helps improve traction when vehicles are on slippery surfaces by keeping drive wheels from spinning. ATC works automatically in two ways.

- If a drive wheel starts to spin, ATC decreases air pressure to brake the wheel. This transfers engine torque to the wheels with better traction.

- If all of the drive wheels spin, ATC reduces engine torque to provide improved traction.

If the vehicle is equipped with Automatic Traction Control (ATC), any wheel spin during acceleration turns on the WHEEL SPIN indicator light. The light goes out when the wheel stops spinning. When the light comes on, partially release the throttle pedal until the light goes out. If slippery road conditions continue, turn the axle lock switch on. See [Chapter 9](#) for axle lock instructions.

## CAUTION

**Do not turn the differential lock switch on while the WHEEL SPIN indicator light is on. To do so could damage the rear axle.**

ATC turns itself on and off. Drivers do not have to select this feature. If drive wheels spin during acceleration, the WHEEL SPIN indicator comes on, indicating ATC is active. It goes out when the drive wheels stop spinning.

The ATC option includes a mud or deep snow (TRAC MUD/SNOW) switch. This switch is used to improve traction on soft surfaces such as snow, mud, or gravel by slightly increasing the permissible wheel spin. When the mud or deep snow switch is pressed, the WHEEL SPIN indicator comes on.

The ABS diagnostic (ABS DIAG) switch is a momentary switch that turns on the blink code diagnostic capabilities. It may also be used to disable the traction control for dynamometer testing as described in the next paragraph. For information on troubleshooting with blink code diagnostics, see [Group 42](#) of the *Acterra® Workshop Manual*.

## WARNING

**Failure to disable the ATC before dynamometer testing could result in serious personal injury and damage to the vehicle.**

Vehicles with ATC must have the ATC disabled to test the vehicle on a dynamometer. To disable the ATC, press and hold the ABS diagnostic switch for at least three seconds. Once the system configuration code begins, ATC has been disabled. The WHEEL SPIN indicator comes on and stays on while disabled.

The Meritor WABCO ABS system combines one front-axle control channel with either one rear axle

# Steering and Brake Systems

(the four-sensor system), or two rear axles (the six-sensor system) to form one control circuit. For example, the sensor and solenoid control valve at the left-front axle form a control circuit with the sensor(s) and solenoid valve(s) on the right rear axle(s). During vehicle operation, if the safety circuit senses a failure in any part of the ABS system (a sensor, solenoid control valve, wiring connection, short circuit, etc.), the TRACTOR ABS warning light comes on and the control circuit where the failure occurred is switched to normal braking action. ABS will continue to work on the remaining control circuit. Even if the ABS system is not working to some degree, normal braking ability is maintained. A possible exception would be if a solenoid control valve or combination solenoid control valve is damaged or not working. Since these valves are an integral part of the air brake system, normal braking may be reduced or may not work at all and if they are malfunctioning the vehicle must be parked as quickly and safely as possible.

**IMPORTANT:** If any of the ABS warning lights do not work as described above or come on while driving, repair the ABS system immediately to ensure full antilock braking capability.

During emergency or reduced-traction stops, push the brake pedal steadily until the vehicle comes to a safe stop. Do *not* pump the brake pedal. If the driver pushes the brake pedal hard enough to lock the wheels, the ABS system will control braking to provide steering control and the shortest possible stopping distance.

Although the ABS system improves vehicle control during emergency braking situations, the driver still has the responsibility to drive appropriately for the existing traffic and road conditions. For example, the ABS system cannot prevent an accident if the driver is speeding or following too closely, or going too fast in slippery road surfaces.

## Automatic Slack Adjusters

Automatic slack adjusters are required on all vehicles equipped with air brakes manufactured after October 20, 1994. Automatic slack adjusters should never be manually adjusted except during routine maintenance of the foundation brakes (e.g., replacing shoes), during slack adjuster installation or in an emergency situation.

When the brake pushrod stroke exceeds the legal brake adjustment limit on a vehicle, there is likely a

mechanical problem with the foundation brake components or the adjuster is improperly installed.

Visit a repair facility as soon as possible when brakes equipped with automatic slack adjusters are determined to be out of adjustment.

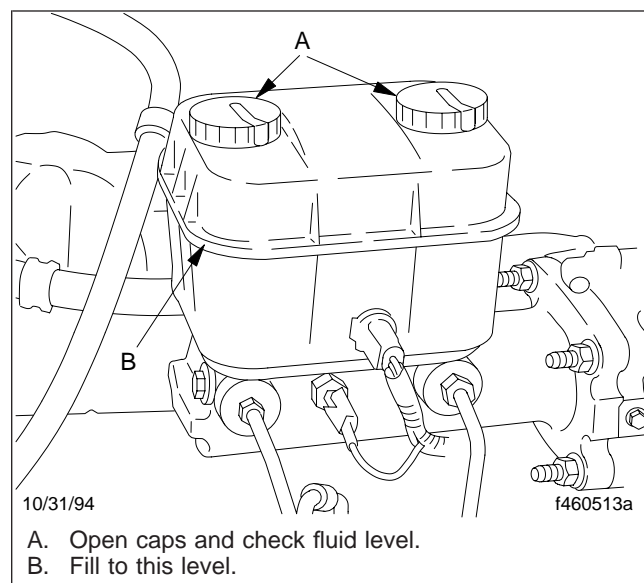
## **! WARNING**

**Manually adjusting an automatic slack adjuster to bring the pushrod stroke within legal limits is likely masking a mechanical problem. Adjustment is not repairing. In fact, continual adjustment of automatic slack adjusters may result in premature wear of the adjuster itself. Further, the improper adjustment of some automatic slack adjusters may cause internal damage to the adjuster, thereby preventing it from properly functioning.**

## Hydraulic Brake System

### General Information

The hydraulic brake system includes a Hydro-Max® power booster, master cylinder, hydraulic brake reservoir (Fig. 6.3), hydraulic lines, a brake rotor on each wheel hub, and a brake caliper and pad assembly at each rotor.



- 10/31/94
- A. Open caps and check fluid level.  
B. Fill to this level.
- f460513a

**Fig. 6.3, Hydraulic Brake Reservoir**

**IMPORTANT:** Fill the master cylinder reservoir to the bottom of the narrow ring of the filler neck. Use only heavy-duty DOT 3 brake fluid in the hydraulic brake system.

The master cylinder supplies hydraulic pressure to the brakes. It is attached to the front of the Hydro-Max power booster. The power booster receives pressurized automatic transmission fluid (ATF) from the power steering system. (The power steering system contains ATF, not the product specifically called power steering fluid.) An electrically powered "reserve" pump cuts in, if fluid pressure falls between the power steering pump and the power booster. The brake system warning light comes on if there is a problem within the system.

If the light comes on, bring the vehicle to a safe stop and correct the problem immediately. Do not attempt to drive until the problem is found and corrected.

For hydraulic brake system troubleshooting and adjustment procedures, see **Group 42** of the *Acterra® Workshop Manual*.

## Operation

Before driving the vehicle, secure all loose items in the cab so that they will not fly forward during a full brake application. Make sure all occupants are wearing seat belts. Check that the brake system warning light is off after releasing the parking brake. If the warning light does not go off, find and correct the problem before continuing to operate the vehicle.

During normal brake stops, pushing the brake pedal slows the vehicle. As the vehicle slows almost to a stop, push in the clutch pedal if there is one, and shift the transmission to neutral. After coming to a stop, apply the parking brake if the vehicle is to be parked.

## Meritor™ WABCO® Antilock Braking System (ABS), Hydraulic Brake Systems

The Meritor WABCO Antilock Braking System (ABS) is an electronic wheel speed monitoring and control system which works with the hydraulic brake system. ABS watches each braking wheel's speed at all times, then *controls* wheel speed during an emergency or reduced-traction stop. In normal braking the

standard hydraulic brake system is in effect, the ABS does nothing.

**IMPORTANT:** For proper ABS system operation, do not change tire sizes. The sizes of the tires installed during production are programmed into the electronic control unit (ECU). Installing different sized tires could result in inaccurate wheel speed signals to the ECU, reduced braking force and longer stopping distances. This could lead to an accident, property damage and personal injury.

ABS uses signal-generating tone wheels and sensors located in the wheel hubs of each sensed axle to measure their speeds. The sensors transmit the wheel speed information to the ECU which compares wheel speeds and a vehicle reference speed. If the calculations indicate a wheel is about to lock, the ECU signals the brake pressure modulator to increase or decrease braking pressure.

The ECU also has a safety circuit which constantly monitors the wheel sensors, brake pressure modulator, and the electrical circuitry. The TRACTOR ABS warning light comes on after the ignition is switched on. The warning light goes out only if all the tractor ABS components are working properly.

The ABS warning light comes on and stays lit when the ignition is switched on. It should go off when the vehicle exceeds four miles per hour. If it does not go off over four miles per hour, there may be an active fault in the hydraulic ABS. If the ABS warning light comes on and stays on, then goes off after the vehicle goes over four miles per hour, there may be a stored fault in the hydraulic ABS. Have the ABS system checked if either situation occurs.

If during vehicle operation the safety circuit senses a failure in any part of the ABS system (a sensor, brake pressure modulator, wiring connection, short circuit, etc.) the TRACTOR ABS warning light comes on and the control circuit where the failure occurred is switched to normal braking action. Even if the ABS system is partially or completely inoperative, normal braking ability is maintained. An exception would be if the brake pressure modulator, or hydraulic fluid line is damaged. As these components are an integral part of the hydraulic brake system, normal braking may be impaired or inoperative.

# Steering and Brake Systems

---

## CAUTION

An accumulation of road salt, dirt, or debris on the ABS tone wheels and sensors can cause the ABS warning light to come on. If the ABS light does come on, the tone rings and sensors should be inspected for corrosion and serviced if necessary. The service should include cleaning of the tone rings and sensors. If any tone ring on a vehicle shows severe corrosion, all tone rings on that vehicle should be replaced.

During winter months in areas where corrosive materials are used on the highways, periodically clean the underside of the vehicle, including the tone rings and sensors, to ensure proper ABS function and to protect the components from corrosion. Clean more frequently when unusually corrosive chemicals are being used.

Before ignition, the dash mounted TRAILER ABS lamp will operate as follows when a compatible trailer is properly connected to a tractor:

- When the ignition key is turned to the on position, the trailer ABS lamp will illuminate momentarily, then turn off.
- If the lamp comes on momentarily during vehicle operation, then shuts off, a fault was detected and corrected.
- If the lamp comes on and stays on during vehicle operation, there is a fault with the trailer ABS. Repair the trailer ABS system immediately to ensure full antilock braking capability.

The Trailer ABS lamp will not illuminate unless a compatible trailer is connected to the tractor.

**IMPORTANT:** If any of the ABS warning lights do not work as described above or come on while driving, repair the ABS system immediately to ensure full antilock braking capability.

During emergency or reduced-traction stops, fully depress the service brake until the vehicle comes to a safe stop. Do *not* pump the pedal. With the service brake pedal depressed, the ABS system will control all wheels to provide steering control and a reduced braking distance.

Although the ABS system improves vehicle control during emergency braking situations, the driver still has the responsibility to change driving styles depending on the existing traffic and road conditions.

For example, the ABS system cannot prevent an accident if the driver is speeding or following too closely on slippery road surfaces.

The ABS diagnostic (ABS DIAG) switch is a momentary switch that turns on the blink code diagnostic capabilities. It may also be used to disable the traction control for dynamometer testing. For information on troubleshooting with blink code diagnostics, see **Group 42** of the *Acterra® Workshop Manual*.

## WARNING

**Failure to disable the ATC before dynamometer testing could result in serious personal injury and damage to the vehicle.**

Vehicles with ATC must have the ATC disabled to test the vehicle on a dynamometer. To disable the ATC, press and hold the ABS diagnostic switch for at least three seconds. Once the system configuration code begins, ATC has been disabled. The WHEEL SPIN indicator comes on and stays on while disabled.

# 7

## Engines and Clutches

---

EPA07 Aftertreatment System (ATS) .....	7.1
Engine Starting .....	7.2
Cold-Weather Starting .....	7.5
Starting After an Extended Shutdown or Oil Change .....	7.6
Engine Break-In .....	7.6
Engine Operation .....	7.6
Cold-Weather Operation .....	7.9
Engine Shutdown .....	7.11
High-Altitude Operation .....	7.13
Exhaust Braking System, Optional .....	7.13
Engine Braking System, Optional .....	7.15
Clutches .....	7.15

# Engines and Clutches

---

## EPA07 Aftertreatment System (ATS)

On-road diesel engines built after December 31, 2006, are required to meet EPA07 guidelines for reduced exhaust emissions of particulate matter and nitrogen oxides (NOx). NOx is limited to just over 1 gram per brake horsepower hour (g/bhp-hr), and particulate matter cannot exceed 0.01 g/bhp-hr.

EPA07-compliant engines require ultralow-sulfur diesel (ULSD) fuel, and they should never be run on fuel with sulfur content higher than 15 ppm. In addition, they require low-ash engine oil. The following guidelines must be followed, or the warranty may be compromised.

- Use ultralow-sulfur diesel (ULSD) with 15 ppm sulfur content or less, based on ASTM D2622 test procedure.
- Do not use fuel blended with used engine lube oil.
- Engine lube oil must have a sulfated ash level less than 1.0 wt %, meeting the API CJ-4 index specifications.

**IMPORTANT:** Using non-specification fuels or oils can lead to shortened diesel particulate filter (DPF) cleaning or exchange intervals. For example, using CI-4+ oil with 1.3% sulfated ash (30% more ash content) may result in the need for DPF cleaning or exchange 20 to 30% sooner than would normally be required.

The "exhaust system" in EPA07-compliant vehicles is called the aftertreatment system (ATS). The ATS varies according to engine manufacturer and vehicle configuration, but instead of a muffler, an aftertreatment system has a device that outwardly resembles a muffler, called the aftertreatment device (ATD).

**IMPORTANT:** See your engine operation manual for complete details and operation of the aftertreatment system.

Inside the ATD on Mercedes-Benz, Detroit Diesel, and Cummins engines, the exhaust first passes over the diesel oxidation catalyst (DOC), then it passes through the diesel particulate filter (DPF), which traps soot particles. If exhaust temperature is high enough, the trapped soot is reduced to ash, in a process called passive regeneration (regen). **Passive regen-**

**eration** occurs as the vehicle is driven normally under load; the driver is not even aware that it is happening. The harder an EPA07 engine works, the better it disposes of soot, as the exhaust heat alone is enough to burn the soot to ash. Over the course of a workday, however, passive regeneration cannot always keep the ATD filter clean, so the filter must undergo **active regeneration**. In active regeneration, extra fuel is injected into the exhaust stream to superheat the soot trapped in the DPF and turn it to ash. Active regeneration happens only when the vehicle is moving above a certain speed, determined by the engine manufacturer. Consult manufacturers' documentation for details.

Both active and passive regeneration happen automatically, without driver input.

**NOTE:** Caterpillar engines do not use a DOC; CAT engines burn diesel fuel at the regeneration heat to superheat the exhaust and burn the trapped soot to ash. Engine software monitors and controls this process.

If conditions do not provide for at-speed active regeneration, the vehicle will need a driver-activated **parked regeneration**. The vehicle must be standing still, and the driver must initiate parked regen. Completing a parked regen takes 20 minutes to an hour, depending on ambient conditions.



**During parked regeneration, exhaust temperatures are very high, and could cause a fire, heat damage to objects or materials, or personal injury to persons near the exhaust outlet.**

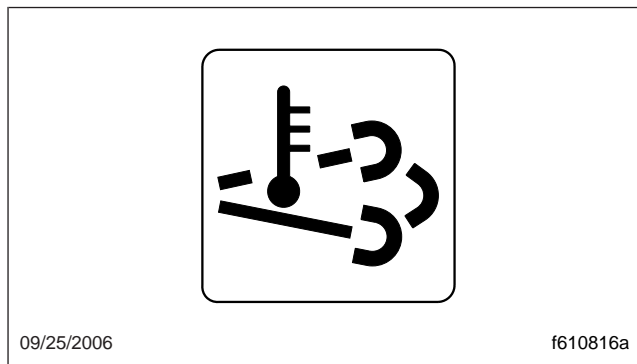
**Before a parked regeneration, make certain the exhaust outlets are directed away from structures, trees, vegetation, flammable materials, and anything else that may be damaged or injured by prolonged exposure to high heat.**

There are three warning lamps in the driver message center that alert the driver of the need to perform a parked regen, clean the filter, or of an engine fault that affects the emissions.

A slow (10-second) flash of the high exhaust system temperature (HEST) lamp, indicates a regeneration is in progress, and the driver is not controlling the engine idle speed.

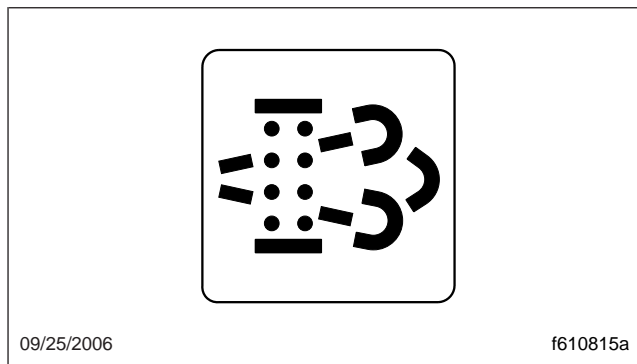


A solid illuminated high exhaust system temperature (HEST) lamp, alerts the operator of high exhaust temperature during the regeneration process, when the speed is below 5 mph (8 km/h). The HEST lamp does not signify the need for any kind of vehicle or engine service; it only alerts the vehicle operator of high exhaust temperatures. Make sure the engine exhaust pipe outlet is not directed at any person, or at any surface or material that will melt, burn, or explode. See [Fig. 7.1](#).



**Fig. 7.1, High Exhaust System Temperature (HEST) Lamp**

A solid yellow diesel particulate filter (DPF) lamp indicates that a parked regen is required soon, and should be scheduled for the earliest convenient time. See [Fig. 7.2](#). A blinking yellow DPF lamp indicates that a parked regen is required immediately, or an engine derate may occur.

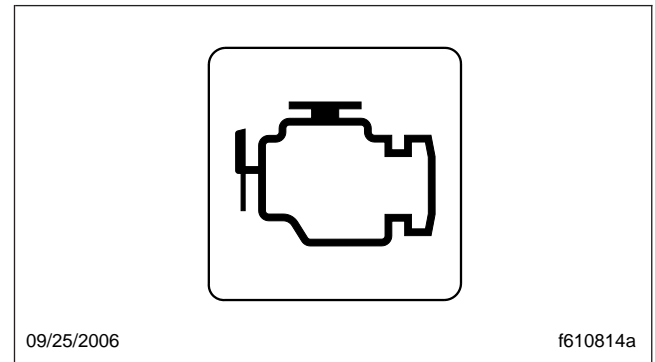


**Fig. 7.2, Diesel Particulate Filter (DPF) Status Lamp**

A solid yellow malfunction indicator lamp (MIL) indicates an engine fault that affects the emissions. See [Fig. 7.3](#).

Diesel particulate filter servicing must be performed by an authorized technician, and a record must be maintained for warranty purposes. The record must include:

- date of cleaning or replacement;
- vehicle mileage;
- particulate filter part number and serial number.



**Fig. 7.3, Malfunction Indicator Lamp (MIL)**

The request/inhibit regen switch ([Fig. 7.4](#)), located on the dash, may have three selectable positions:

- request regeneration;
- default (can include appropriate normal state condition—either in an automatic regeneration or inhibit state);
- inhibit regeneration.

**NOTE:** The regen switch can start an active regen only when at least one of two conditions exists: either the DPF light is lit, or the engine software calls for it. If neither of those conditions exist, the regen switch cannot cause a regeneration to happen.

The function of the switch will vary by the engine make and model in the vehicle. See the engine operation manual for switch operation details.

## Engine Starting

**NOTE:** Before starting the engine, read [Chapter 2](#) for detailed information on how to read the instruments and operate the controls.

# Engines and Clutches

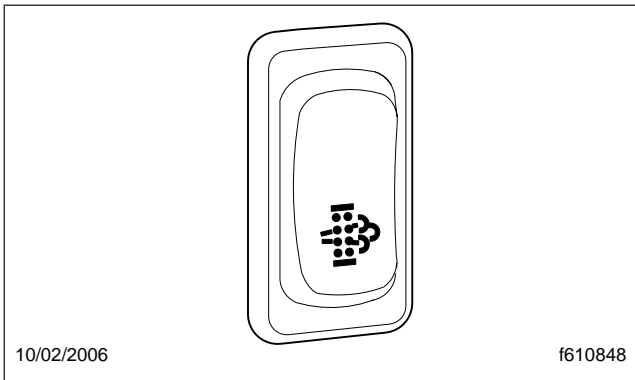


Fig. 7.4, Request/Inhibit Regen Switch

## CAUTION

When starting a vehicle equipped with a manual transmission and clutch lockout switch, the clutch pedal must be fully depressed during the entire start sequence. Failure to do so can cause the pinion to release and re-engage, which could cause ring gear and starter pinion damage.

If a vehicle does not start on the first attempt, make sure that the engine has completely stopped rotating before reapplying the starter switch. Failure to do so can cause the pinion to release and re-engage, which could cause ring gear and starter pinion damage.

Moving a vehicle with the starter and/or using the starter to bump the engine for maintenance procedures is strictly prohibited. Use of these methods to bump the engine over or move the vehicle can cause the pinion to release and re-engage, which could cause ring gear and starter pinion damage.

**IMPORTANT:** Ring gear and starter pinion damage caused by improper starting procedures is not warrantable.

Whenever you start an engine, watch for any signs of engine problems. If the engine vibrates, misfires, or makes unusual noises, turn the engine off as soon as possible and determine the cause of the problem. Frequently, engine damage may be avoided by a quick response to early indications of problems.

## Pre-Start

**NOTE:** These pre-start steps apply to all engines.

1. Perform the engine pretrip inspection and daily maintenance checks in [Chapter 11](#).
2. Set the parking brake.
3. For manual transmissions, place the transmission in neutral and disengage the clutch.

For automatic transmissions, make sure the transmission shift control is in neutral or park.

**NOTE:** On vehicles equipped with a neutral start switch, the transmission must be in neutral before the engine can be started. For air start systems, check the air supply before starting the engine. There must be 100 psi (689 kPa) of air pressure available.

## Starting Precautions, All Engines

### WARNING

Do not use any starting aid, such as ether, in engines with an intake air preheater. This could cause an explosion, resulting in serious personal injury or death.

### CAUTION

Do not crank the engine for more than 30 seconds at a time. Wait two minutes after each try to allow the starter to cool. Failure to do so could cause starter damage.

**NOTE:** Some starters are equipped with optional overcrank protection. If overcranking occurs, a thermostat breaks the electrical circuit to the starter motor until the motor has cooled.

### CAUTION

Protect the turbocharger during the start-up by not opening the throttle or accelerating the engine above 1000 rpm until normal engine idle oil pressure registers on the gauge.

## Mercedes-Benz

NOTE: Before doing these steps, do the steps in "Pre-Start."

### CAUTION

Never attempt to start any Mercedes-Benz electronic engine using ether or any other starting fluid. Serious engine damage could result.

1. Turn the ignition switch to the on position (Fig. 7.5). All the electronic gauges on the instrument and control panel complete a full sweep of their dials, the warning and indicator lights light up, and the buzzer sounds for three seconds.

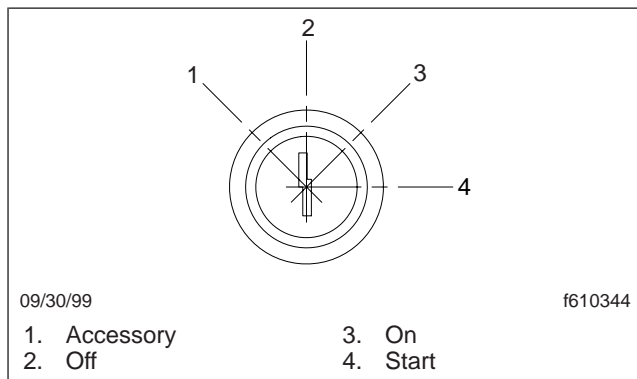


Fig. 7.5, Ignition Switch Positions

**IMPORTANT:** On vehicles equipped with an intake air preheater, wait until the INTAKE HEATER indicator goes out before attempting to start the engine.

2. Turn the ignition switch to the start position. Without touching the throttle pedal, start the engine.
3. Idle the engine for one to three minutes at 600 rpm (700 rpm for 4-cylinder engines) before operating the engine under load.
4. Check the oil pressure gauge for any drop in lubricating oil pressure or mechanical malfunction in the lubricating oil system. Minimum oil pressure at idle is 7 psi (50 kPa).

### CAUTION

Do not rev the engine if the oil pressure gauge indicates no oil pressure. Shut down the engine if no oil pressure appears within approximately ten seconds. Check to determine the cause of the problem. Operating the engine with no oil pressure will damage the engine.

## Caterpillar

NOTE: Before doing these steps, do the steps in "Pre-Start."

1. Turn the ignition switch to the on position (Fig. 7.5). The CHECK ENGINE indicator comes on for five seconds. The INTAKE HEATER indicator comes on for a minimum of two seconds, regardless of coolant temperature.

**IMPORTANT:** If the INTAKE HEATER indicator stays on for more than two seconds, wait until the indicator goes out before attempting to start the engine.

2. Turn the ignition switch to the start position. Release the switch the moment the engine starts.
  - 2.1 If the engine does not start after 15 to 20 seconds of cranking, turn the ignition switch off.
  - 2.2 Wait two minutes to allow the starter motor to cool. Turn the ignition switch back to the on position and try to start the engine again.
  - 2.3 As soon as the engine starts, release the ignition switch, allowing the engine to run at a slow idle.

### CAUTION

If the oil pressure is too low, shut down the engine immediately to prevent serious damage. If the vehicle is equipped with an automatic shut-down system, the engine will shut down after 30 seconds.

3. The engine may be operated at low load and speed once the engine oil pressure has reached 10 psi (69 kPa) and air pressure (if applicable) has reached 64 to 76 psi (441 to 524 kPa).

# Engines and Clutches

---

- When the engine has reached the minimum operating temperature of 160°F (71°C), the engine may be operated at full load.

## Cummins



**Never attempt to start any Cummins IS series electronic engine (ISB, ISC, ISL) using ether or any other starting fluid. Serious engine damage could result.**

**NOTE:** Before doing these steps, do the steps in "Pre-Start."

- Turn the ignition switch to the on position (**Fig. 7.5**). The CHECK ENGINE indicator will come on. The INTAKE HEATER indicator comes on for a minimum of two seconds, regardless of coolant temperature. Leave the ignition switch on until the CHECK ENGINE indicator goes out.

**IMPORTANT:** If the INTAKE HEATER indicator stays on for more than two seconds, wait until the indicator goes out before attempting to start the engine.

- Turn the ignition switch to the start position. After the engine starts, release the key.
- Bring the engine up to operating speed gradually as it warms up and develops stable oil pressure.

**NOTE:** When the engine is started, it takes a short time to build up a lubricating oil film between the shafts and bearings, and between the pistons and liners. The oil pressure gauge indicates any drop in lubricating oil pressure within 15 seconds of engine start-up.

- If minimum engine oil pressure at idle of 10 psi (69 kPa) does not register within 15 seconds, shut down the engine.



**Protect the turbocharger during the start-up by not opening the throttle or accelerating the engine above 1000 rpm until minimum engine idle oil pressure registers on the gauge. Failure to do so could damage the turbocharger.**

- Idle the engine for three to five minutes at 1000 rpm before operating the engine under load.

## Cold-Weather Starting



**Do not use any starting aid, such as ether, in engines with an intake air preheater. This could cause an explosion, resulting in serious personal injury or death.**

Modern electronic engines do not normally require special starting aids. At low temperatures, intake air preheaters, manifold preheaters, or water jacket heaters are sometimes used to assist in starting.

## Mercedes-Benz

The intake air preheater is activated by turning the ignition switch to the on position (**Fig. 7.5**). If the engine is at normal temperature, the INTAKE HEATER indicator goes out after two seconds.

If the temperature is low enough to require the heater, the INTAKE HEATER indicator stays on while the intake air preheater warms up. After the indicator goes out, start the engine. If the engine doesn't start after about 30 seconds of cranking, turn the key to the off position and wait two minutes, then repeat the starting procedure.

**NOTE:** If the engine doesn't start on the second try, wait at least five minutes before using the intake air preheater again.

## Caterpillar

Caterpillar truck engines with direct injection are designed to start at temperatures above 32°F (0°C) without using start systems. If the temperature is below 32°F (0°C), startability will be improved by the use of an automatic ether injection system and/or a jacket water heater.



**Directing ether at the heater element in the intake air preheater could cause extensive engine damage.**

The intake air preheater is activated by turning the ignition switch to the on position (Fig. 7.5). If the engine is at normal temperature, the INTAKE HEATER indicator goes out after two seconds.

If the temperature is low enough to require the heater, the INTAKE HEATER indicator stays on while the intake air preheater warms up. After the indicator goes out, start the engine.

**IMPORTANT:** Attempting to start the engine before the INTAKE HEATER indicator has gone off could result in excessive white smoke at start-up.

If the engine doesn't start after 15 to 20 seconds of cranking, turn the key to the off position and wait two minutes; then repeat the starting procedure.

## Cummins

The cold-start system approved for use on Cummins engines has been based upon starting aid capabilities to  $-25^{\circ}\text{F}$  ( $-32^{\circ}\text{C}$ ).

Turn the ignition switch to the on position (Fig. 7.5). If the engine is at normal temperature, the INTAKE HEATER indicator goes out after two seconds.

If the temperature is low enough to require the heater, the INTAKE HEATER indicator stays on while the intake air preheater warms up. After the indicator goes out, start the engine.

Run the engine slightly above idle until oil pressure shows on the gauge. If oil pressure doesn't show on the gauge within 30 seconds of starting, turn the key to the off position and wait one minute; then repeat the starting procedure.

## Starting After an Extended Shutdown or Oil Change

Do the following steps after an oil change or after the engine has been shut down for more than three days:

1. Disconnect the electrical connector from the fuel pump solenoid valve.
2. Crank the engine until oil pressure shows on the gauge.
3. Connect the electrical connector to the fuel pump solenoid valve.

4. Start the engine. After one minute, shut down the engine and check for leaks.
5. Allow five minutes for the oil to settle, then check the engine oil level and add oil if needed. Do not overfill.

## Engine Break-In

Every engine is tested on a dynamometer before shipment, eliminating the need for a break-in period. Before running the engine for the first time, follow the instructions in the engine operator's manual for the vehicle.

## Engine Operation



**Do not operate the engine in an area where flammable vapors such as gasoline or diesel fumes are present. Shut down the engine when in an area where flammable liquids or gases are being handled. Failure to observe these precautions could result in serious injury or death.**

All diesel engines have been built to comply with the requirements of the Federal (U.S.) Clean Air Act. Once an engine is placed in service, the responsibility for meeting both state and local regulations is with the owner/operator. Good operating practices, regular maintenance, and correct adjustments are factors which will help to stay within the regulations.

Proper maintenance of the engine, which is the responsibility of the owner/operator, is essential to keep the emission levels low.

## Engine Protection

On electronic engines, an engine-protection system monitors all engine sensors and electronic components, and recognizes system malfunctions. If a critical fault is detected, an amber check-engine warning lamp and a red stop-engine lamp illuminate.

The standard parameters that are monitored for engine protection are: low coolant level, high coolant temperature, low oil pressure, high soot level (DPF), and uncontrolled DPF regeneration.

# Engines and Clutches

---

## Amber Check-Engine Warning Lamp

When the amber check-engine warning lamp comes on for any reason, the vehicle can still be operated, and the driver can proceed to the required destination. This condition should be reported to an authorized service center as soon as possible.

## Red Stop-Engine Lamp

 **WARNING**

**When the red stop-engine light illuminates, most engines are programmed to shut down automatically within 30 seconds. The driver must immediately move the vehicle to a safe location at the side of the road to prevent causing a hazardous situation that could cause bodily injury, property damage, or severe damage to the engine.**

The red stop-engine lamp illuminates to indicate that the engine-protection system has been activated. The conditions that will cause the red stop-engine lamp to come on are:

- high coolant temperature
- loss of coolant
- low oil pressure
- high soot level (DPF)
- uncontrolled DPF regeneration

On some engines, the engine ECU will derate the engine, allowing it to run at low rpm and slow vehicle speed, until the vehicle can be driven to a safe location or to a service facility. On other engines, the engine ECU will first derate the engine, then if the condition does not improve, shut it down completely 30 seconds after the light comes on. The driver must safely bring the vehicle to a stop on the side of the road before the engine shuts down.

To restart the engine (override the shutdown command) turn the ignition switch to OFF, leave it there a few seconds, and turn the switch to START. The engine will run for a short period and shut down again if the condition does not improve.

**IMPORTANT:** Do not attempt to restart the engine while the vehicle is moving. Bring the vehicle to a safe stop and restart the engine with the vehicle stopped.

## Stop-Engine Override Switch

If the vehicle is equipped with a stop-engine override (SEO) switch, it can be used to override the shutdown sequence. This override resets the shutdown timer, restoring power to the previous level before the red stop-engine lamp was illuminated. The switch must be recycled after five seconds to obtain a subsequent override.

 **CAUTION**

**Using the override button so the engine operates for an extended period may result in engine damage. The operator has the responsibility to take action to avoid engine damage.**

## Mercedes-Benz

While you are driving, watch for any signs of engine problems. If the engine overheats, uses excessive fuel or lubricating oil, vibrates, misfires, makes unusual noises, or shows an unusual loss of power, turn the engine off as soon as possible and determine the cause of the problem. Frequently, engine damage may be avoided by a quick response to early indications of problems.

1. Use the tachometer to determine when to shift. Follow the pattern on the shift lever when moving through the gears.
2. Depending on the vehicle gearing, the posted speed limit can sometimes allow operation in either of the top two gears; however, for improved operating efficiency (fuel economy and engine life), operate in the top gear at reduced rpm rather than in the next lower gear at the maximum rpm.
3. Cruise at partial throttle whenever road conditions and speed requirements permit. This driving technique permits operating within the most economical power range of the engine.
4. Use lower gears in steep downhill driving. Normally, the gear used to descend a hill is the same gear used to climb a hill of the same grade.
5. Never allow the engine to exceed the rated speed. Use the exhaust brake and the optional constant-throttle brake, if installed, to lower engine rpm below the rated speed.

6. Never allow the engine to idle for more than 30 minutes. Excessive idling can cause oil to leak from the turbocharger.

## CAUTION

**Stop the engine at the first sign of malfunction. Almost all malfunctions give some warning to the operator before significant damage occurs. Many engines are saved because alert operators heed the warning signs (sudden drop in oil pressure, unusual noises, etc.) and immediately shut down the engine.**

NOTE: Long periods of idling are not good for an engine because the combustion chamber temperatures drop so low the fuel may not burn completely. This will cause carbon to clog the injector spray holes and piston rings, and may result in stuck valves.

If the engine coolant temperature becomes too low, raw fuel will wash the lubricating oil off the cylinder walls and dilute the crankcase oil, causing all moving parts of the engine to suffer from poor lubrication.

## Caterpillar

Proper operation and maintenance are key factors in obtaining the maximum life and economy of a vehicle engine. Follow the directions in the Caterpillar *Operation and Maintenance Manual* and this manual for trouble-free, economical engine operation.

1. Operate the engine at low load. After normal oil pressure is reached and the temperature gauge needle begins to move, the engine may be operated at full load.

Caterpillar electronic engines automatically idle at 900 to 1000 rpm for the correct warm-up time after a cold engine start when the air temperature is lower than 40°F (5°C). These electronic engine systems will reduce the idle speed to 600 rpm when the engine has warmed sufficiently to operate the vehicle.

**IMPORTANT:** Fuel heaters used on vehicles with Caterpillar electronic engines could cause excessive fuel temperatures that affect engine performance and operation of the electronic engine controls. If a fuel heater is used, make sure

it has thermostatic controls. If the fuel heater has a timer, set the timer to activate only for a limited period of time before the engine starts. Make sure the fuel heater is used only for starting the engine.

2. Select a gear that allows a smooth, easy start without increasing engine speed above low idle or slipping the clutch. Engage the clutch smoothly. Jerky starts waste fuel and put stress on the drivetrain.

It is not necessary to accelerate Caterpillar electronic engines to governed speed in the lower gears to get the vehicle moving, except in a high power demand situation such as starting on a grade.

3. Continue to upshift until cruising speed is reached. Use only the rpm needed to make an upshift into the next gear. The engine speed needed to make an upshift increases as the truck speed increases. If the truck can be operated in a higher gear after reaching the desired speed, select the highest gear available that will pull the load. Experience with your vehicle will show you what rpm is needed to make upshifts under various conditions. This progressive shifting technique will lower fuel costs because the engine will be operating at the lowest rpm needed to pull the load.

Caterpillar electronic engines can be programmed to limit engine rpm while the vehicle is operated in the lower and higher gears. This feature assists the driver in following progressive shifting techniques.

4. On uphill grades, begin downshifting when the engine rpm falls to 1200 rpm. Fuel economy will be best if you let the engine lug back to around this speed before you downshift. Downshift until a gear is reached in which the engine will pull the load. Let the engine lug down if you can make it to the top of a hill without downshifting.

**IMPORTANT:** Do not allow Caterpillar electronic engines to exceed 2300 rpm (2100 rpm if equipped with an exhaust brake).

5. On a downhill grade, do not coast or put the transmission in neutral. Select the correct gear that does not allow the engine to exceed its maximum speed. Use the brakes to limit the truck speed.

# Engines and Clutches

---

A simple rule to follow is to select the same gear (or one gear lower) that would be needed to go up the grade.

6. As with any engine, prolonged idling of Caterpillar engines is not recommended. An idling engine wastes fuel and, if left unattended, is also unsafe.

Caterpillar engines can be programmed to shut off automatically after a specified idling time. The vehicle transmission must be in neutral and the parking brake must be set for the automatic shut-off option to work.

## Cummins

Follow the directions in the *Cummins Operation and Maintenance Manual* and in this manual for trouble-free, economical vehicle engine operation.

1. Cummins diesel engines produce high horsepower and peak torque characteristics at low rpm. Because of this, it is not necessary to keep the engine "wound up" to deliver the required horsepower at the wheels. These characteristics may also result in less shifting and make shifting at lower rpm (to peak torque) more practical.
2. Depending on the vehicle gearing, the posted speed limit can sometimes allow operation in either of the top two gears; however, for improved operating efficiency (fuel economy and engine life), operate in the top gear at reduced rpm rather than in the next lower gear at the maximum rpm.
3. Cruise at partial throttle whenever road conditions and speed requirements permit. This driving technique permits operating within the most economical power range of the engine.
4. When approaching a hill, open the throttle smoothly to start the upgrade at full power, then shift down as desired to maintain the optimum vehicle speed. The high torque of Cummins engines may permit topping some grades without shifting.
5. Cummins engines are designed to operate over a wide speed range. More frequent shifting than necessary does not allow proper utilization of this flexibility. The driver who stays in top gear and uses the wider speed range will achieve the best fuel economy.

6. The Cummins diesel engine is effective as a brake on downhill grades, but care must be used not to overspeed the engine going downhill. The governor has no control over engine speed when the engine is being pushed by the loaded vehicle.

Never turn off the ignition switch while going downhill. With the engine still in gear, fuel pressure will build up against the shutdown valve and may prevent it from opening when the ignition key is turned on.

---

## CAUTION

---

**Do not allow the engine to exceed its governed speed, or serious engine damage could result.**

7. Use a combination of brakes and gears to keep the vehicle under control at all times and to keep the engine speed below the rated governed rpm.

## Cold-Weather Operation

**IMPORTANT:** If a winterfront is used on a vehicle with an electronic engine equipped with a charge air cooler, make sure that there are slit openings distributed across the face of the winterfront to allow airflow through the entire charge-air-cooler core. Do not use a winterfront with closed areas that block uniform air flow across any sections of the charge-air-cooler crossflow tubes. This will adversely affect the operation and durability of the charge air cooler.

## Mercedes-Benz

Special precautions must be taken during cold weather. For service products to use in cold weather, see **Chapter 5** of the *MBE900 Engine Operator's Manual*.

**IMPORTANT:** At outside air temperatures below  $-4^{\circ}\text{F}$  ( $-20^{\circ}\text{C}$ ), a coolant preheater is recommended.

1. Check for cracks in the battery cases, for corrosion of the terminals, and for tightness of the cable clamps at the terminals. Run a load test to determine full or partial charging. Charge the batteries to full capacity. Replace any battery that is unable to hold full charge or is physically damaged.



2. Check the alternator output. Check the condition and tension of the poly-V belt.
3. Periodically check the coolant mixing ratio (concentration of antifreeze in the coolant). Add more if necessary. The coolant mixing ratio should never rise above 55 percent antifreeze.
4. Use low-viscosity lubricating oils for adequate lubrication.
5. At temperatures below 32°F (0°C), do not use summer-grade (2-D) diesel fuel. To avoid fuel problems due to paraffin separation, use winter-grade (1-D or winterized 2-D) diesel fuel only.
6. If the use of unblended summer-grade diesel fuel in winter cannot be avoided, install a thermostatically controlled fuel heater to prevent wax from clogging the fuel filters, and formation of ice crystals from water in the fuel. If a fuel heater is used, make sure it has thermostatic controls to prevent excessive heating of the fuel in warm weather. Excessive heating of fuel can cause a loss of engine power.

## Caterpillar

If the engine is in good mechanical condition and the precautions necessary for cold-weather operation are taken, ordinary cold weather will not cause difficulty in starting or loss of efficiency.

If the engine does not start, prime the fuel system.

For cold-weather operation, use the following guidelines:

1. When starting the engine in temperatures below 32°F (0°C), use engine lubricants of lower viscosity. See the engine operation and maintenance manual for specifications.
2. When operating in temperatures below 32°F (0°C), use sufficient antifreeze solution in the cooling system to prevent freezing.
3. During cold weather, give more attention to the condition of the batteries. Test them frequently to ensure sufficient power for starting. Inspect all switches and connections in the electrical system and keep them in good condition to prevent losses through poor contacts. See **Group 15** of the *Acterra® Workshop Manual* for detailed information.

4. If so equipped, turn off the battery disconnect switch after the engine is stopped to prevent battery discharge while the starter motor is cooling.

For starting below 0°F (–18°C), an optional cold-weather starting assist is recommended. For temperatures below –10°F (–23°C), consult your Caterpillar dealer for recommendations.

## **WARNING**

**Do not use any starting aid, such as ether, in engines with a cold start manifold heater. This could cause an explosion and serious personal injury or death.**

5. Customer parameters may include cold mode operation. When the coolant temperature is below 64°F (18°C), the system puts the engine in cold mode, limiting engine power, advancing timing, and adjusting the low idle to 600 rpm to improve warm-up time. The system will keep the engine in cold mode until coolant temperature rises above 64°F (18°C) or until the engine has been running for 12 minutes. The system will then stop the cold mode and allow the engine to operate normally.
6. Fuel cloud point is the temperature at which wax crystals become visible, which is generally above the pour point of the fuel. To keep the fuel filter elements from plugging with wax crystals, the cloud point should be no higher than the lowest ambient temperature at which the engine must start.

## Cummins

Satisfactory performance of a diesel engine operating in low ambient temperatures requires modification of the engine, surrounding equipment, operating practices, and maintenance procedures. The lower the temperatures the greater the amount of modification required, and yet with the modifications applied, the engines must still be capable of operation in warmer climates without extensive changes.

The following information is provided to engine owners, operators, and maintenance personnel on how the modifications can be applied to get satisfactory performance from their diesel engines.

There are three basic objectives:

# Engines and Clutches

---

1. Reasonable starting characteristics, followed by practical and dependable warm-up of the engine and equipment.
2. A unit or installation which is as independent as possible from external influences.
3. Modifications which maintain satisfactory operating temperatures with a minimum increase in maintenance of the equipment and accessories.

If satisfactory engine temperature is not maintained, higher maintenance cost will result due to increased engine wear.

Special provisions to overcome low temperatures are definitely necessary, whereas a change to a warmer climate normally requires only a minimum of revision. Most of the accessories should be designed in such a way that they can be disconnected so there is little effect on the engine when they are not in use.

The two most commonly used terms associated with preparation of equipment for low-temperature operation are "winterization" and "arctic specifications."

Winterization of the engine and/or components so that starting and operating are possible in the lowest temperature to be encountered requires:

- Proper lubrication with low-temperature lubricating oils.
- Protection from the low-temperature air. The metal temperature does not change, but the rate of heat dissipation is affected.
- Fuel of the proper grade for the lowest temperature.
- Heat to raise the engine block and component temperatures to at least  $-25^{\circ}\text{F}$  ( $-32^{\circ}\text{C}$ ) for starting in lower temperatures.
- Electrical equipment capable of operating in the lowest expected temperature. All switches, connections, and batteries in the electrical system should be inspected and kept in good condition to prevent losses through poor contacts.

Arctic specifications refer to the design of material and specifications of components necessary for satisfactory engine operation in extremely low temperatures to  $-64^{\circ}\text{F}$  ( $-53^{\circ}\text{C}$ ). Contact the nearest Sterling dealer or Cummins engine dealer, to obtain the special items required.



## CAUTION

**"Antileak" antifreezes are not recommended for use in Cummins engines. Although these antifreezes are chemically compatible with DCA water treatment, the "antileak" agents may clog the coolant filters.**

**IMPORTANT:** Fuel heaters used on vehicles with Cummins CELECT engine systems could cause high fuel temperatures that affect engine performance and operation of the electronic engine controls. If a fuel heater is used, make sure it has thermostatic controls. If the fuel heater has a timer, set the timer to activate only for a limited period of time before the engine starts. Make sure the fuel heater is used only for starting the engine.

## Engine Shutdown

### Mercedes-Benz

If any the following occur, shut down the engine immediately.

- The oil pressure swings back and forth or falls sharply.
  - Engine power and rpm fall, even though the accelerator pedal remains steady.
  - The exhaust pipe gives off heavy smoke.
  - The coolant and/or oil temperature climb abnormally.
  - Abnormal sounds suddenly occur in the engine or turbocharger.
1. With the vehicle stopped, apply the parking brakes and put the transmission in neutral.



## CAUTION

**Idle the engine one to two minutes before shutting it down, if this can be done without damage to the engine. After hard operation, shutting down the engine without idling may cause damage to the turbocharger.**

2. Allow the engine to idle one to two minutes before shutting it down. This allows the lubricating oil and the coolant to carry heat away from the

combustion chambers, bearings, shafts, and seals. The extreme heat may cause bearings to seize or oil seals to leak.

**IMPORTANT:** Bearings and seals in the turbocharger are subjected to the high heat of combustion exhaust gases. While the engine is running, this heat is carried away by oil circulation, but if the engine is stopped suddenly the turbocharger temperature may rise as much as 115°F (61°C).

## CAUTION

**Except in emergency, do not shut down the MBE900 engine when the coolant temperature is above 194°F (90°C). To do so could damage the engine.**

3. Turn off the ignition switch and shut down the engine.

## Caterpillar

## CAUTION

**Stopping the engine immediately after it has been working under load can result in overheating and accelerated wear of the engine components. Excessive temperatures in the turbocharger centerhousing will cause oil coking problems. Follow the procedure, outlined below, to allow the engine to cool.**

1. With the vehicle stopped, apply the parking brakes.
2. Reduce the engine speed to low idle.
3. Place the transmission shift lever in neutral.

**NOTE:** If the engine has been operating at low loads, run it at low idle for 30 seconds before stopping. If the engine has been operating at highway speed or at high loads, run it at low idle for three minutes to reduce and stabilize internal engine temperatures before stopping.

4. Turn off the ignition key to shut down the engine.
5. If equipped with an idle shutdown timer, it can be set to shut the engine down after a preset amount of time. Ninety seconds before the preset shutdown time, the CHECK ENGINE indica-

tor will begin to flash at a rapid rate. If the position of the clutch pedal or service brake changes during this final ninety seconds (diagnostic lamp flashing) the idle shutdown timer will be disabled until reset.

6. After stopping the engine, fill the fuel tank.
7. Check the crankcase oil level while the engine is stopped. Maintain the oil level between the ADD and FULL marks on the dipstick.
8. If temperatures below 32°F (0°C) are expected, allow the engine water jacket expansion tank to cool, then check the coolant for proper antifreeze protection. The cooling system must be protected against freezing to the lowest expected outside temperature. Add permanent-type antifreeze if required.
9. Repair any leaks, perform minor adjustments, tighten loose bolts, etc. Observe the vehicle mileage or the service meter reading, if so equipped. Perform periodic maintenance as instructed in the Lubrication and Maintenance Chart in the *Caterpillar Operation and Maintenance Management* manual.

## Cummins

1. With the vehicle stopped, apply the parking brakes and put the transmission in neutral.
2. It is important to idle an engine three to five minutes before shutting it down. This allows the lubricating oil and the water to carry heat away from the combustion chambers, bearings, shafts, etc. This is especially important with turbocharged engines.

Bearings and seals in the turbocharger are subjected to the high heat of combustion exhaust gases. While the engine is running this heat is carried away by oil circulation, but if the engine is stopped suddenly, the turbocharger temperature may rise as much 115°F (61°C). The extreme heat may cause bearings to seize or oil seals to leak.

3. Do not idle the engine for excessively long periods. Long periods of idling are not good for an engine because the combustion chamber temperatures drop so low the fuel may not burn completely. This will cause carbon to clog the injector spray holes and piston rings and may result in stuck valves.

# Engines and Clutches

---

If the engine coolant temperature becomes too low, raw fuel will wash the lubricating oil off the cylinder walls and dilute the crankcase oil causing all moving parts of the engine to suffer from poor lubrication.

4. If the engine is not being used, shut it down by turning the ignition switch off.

## CAUTION

**Stop the engine at the first sign of malfunction. Almost all malfunctions give some warning to the operator before significant damage occurs. Many engines are saved because alert operators heed the warning signs (sudden drop in oil pressure, unusual noises, etc.) and immediately shut down the engine.**

## High-Altitude Operation

Engines lose horsepower when operated at high altitude because the air is too thin to burn as much fuel as at sea level. This loss is about three percent for each 1000 feet (300 m) altitude above sea level for a naturally aspirated engine. Most turbocharged engines are rated for higher altitudes than naturally aspirated engines.

An engine will have smoky exhaust at high altitudes unless a lower gear is used. The engine will not demand full fuel from the fuel system unless the engine is altitude-compensated by the use of a turbocharger. Shift gears as needed to avoid excessive exhaust smoke.

## Exhaust Braking System, Optional

### General Information

An exhaust brake is an optional auxiliary braking system that assists but does not replace the service brake system. The exhaust brake switch, located on the control panel, in combination with the accelerator and clutch pedals, allows the driver to make maximum use of the exhaust brake in off-highway and mountain driving as well as in traffic or high-speed highway driving.

The exhaust brake is a butterfly-type valve mounted in the exhaust pipe. When the driver's foot is not on the accelerator pedal and the exhaust brake switch is

in the on position, an air cylinder shuts the butterfly valve which restricts the flow of exhaust gases and retards the engine. This retarding action is carried through the engine and drivetrain, slowing the vehicle and reducing the need for frequent service brake applications.

Exhaust brakes are not intended for use as the primary braking system during vehicle operation.

### Starting the Engine

Before starting the engine, make sure that the exhaust brake switch is in the off position. Do not turn the exhaust brake on until the engine has reached normal operating temperatures.

### Driving Downhill

While approaching a steep grade, make sure that the exhaust brake switch is in the on position. The exhaust brake comes on as soon as you remove your foot from the accelerator pedal. While going down the grade, use a low enough gear to safely descend with a minimum application of the service brakes. As a general guideline, use the same gear as you would to ascend the hill.

## WARNING

**Do not use the exhaust brake when driving on slippery or low-traction road surfaces. Failure to follow this precaution could result in a loss of vehicle control and possible personal injury or property damage.**

### Exhaust Brake Operating Characteristics

When you remove your feet from both the accelerator and clutch pedals and the exhaust brake switch is in the on position, the exhaust brake is applied. The following conditions should exist if the brake is operating properly:

- A slight change in the sound of the engine may be noticed when the exhaust brake is applied.
- Exhaust smoke should appear normal.
- Engine temperature should remain in the normal operating range.
- Road speed usually decreases when the exhaust brake is applied during a descent. When the vehicle is carrying a heavy load or the

grade is extremely steep, you may need to apply the service brakes occasionally.

- Do not expect a retarding effect similar to sudden hard application of the service brakes. The exhaust brake retards the vehicle with a smooth braking effect.
- During a descent, the tachometer usually shows a drop in rpm depending on the grade and the vehicle load.
- Depending on the grade and vehicle load, you may or may not feel the retarding force acting against your body when the brake is applied. The retarding force of the brake may not always be noticed, but it is actually preventing the vehicle from going much faster.

## Shutting Off the Engine

Make sure the exhaust brake is turned off before shutting off the engine.

## Pacbrake® Exhaust Brake

The Pacbrake exhaust brake is intended as a supplement to the service brakes and will *not* bring the vehicle to a complete stop. The Pacbrake will assist in the control or reduction of road speed in conjunction with, or independent of, the service brakes. The amount of retarding or braking force is controlled by the driver.

## Pacbrake Operation

The Pacbrake is controlled by the exhaust brake switch and the throttle pedal. All applications are additionally affected, controlled, or governed by engine speed through transmission gear selection. The Allison MD3060 transmission has automatic downshifting when the exhaust brake is requested. See the information on the "Allison World Transmission" later in this chapter.

On some applications, when the Pacbrake is in use, it may be necessary to check that the cruise control is not set and that the throttle is in the idle position.

On some applications the engine, transmission, cruise control, and the Pacbrake exhaust brake may electronically interact with each other, which automatically operates their functions. Following are some examples of the programmed options that may be available with the cruise control in the on position:

- The coast mode engages the Pacbrake when the service brake is applied and disengages when the service brake is released.
- The latch mode engages the Pacbrake when the service brake is applied and the Pacbrake remains on after the service brake is released. The Pacbrake is disengaged when another input (depressing the throttle or clutch, engine speed drops below 800 rpm, or the exhaust brake switch is turned off) is supplied.
- The manual mode does not require the cruise control switch to be on and operates the Pacbrake manually at the driver's discretion.

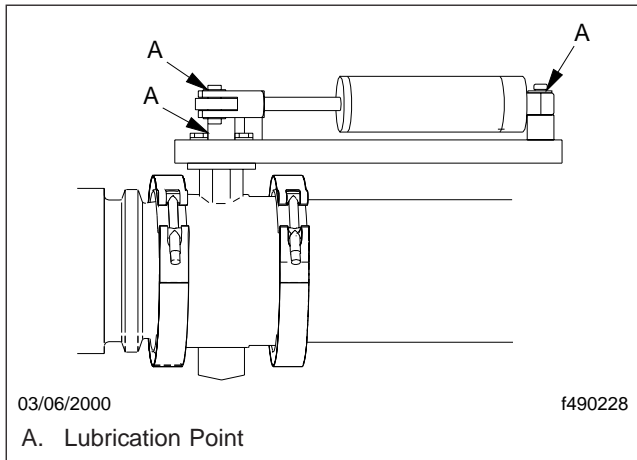
The amount of braking power the engine will develop is related to the speed (rpm) of the engine. The higher the engine rpm, the greater the retarding power.

Certain conditions may require that the transmission be downshifted in order to generate adequate rpm for the amount of retarding power required. Pacbrake exhaust brakes are designed and approved for safe use at 300 rpm above the engine's maximum governed rpm. Refer to individual engine manufacturer's specifications.

The Pacbrake will function best if it is used all of the time. However, if the vehicle is used inconsistently or seasonally, it may be necessary to perform a preventive maintenance procedure.

1. With the engine shut down, use any oil-free or nonpetroleum based high-heat lubricant and spray or coat a sufficient amount on the restrictor valve shaft and the attaching locations at each end of the actuation cylinder. See [Fig. 7.6](#).
2. With your hands or a pair of pliers, motion the valve several times to distribute the lubricant down the shaft and the attaching locations.

**NOTE:** Starting the engine and idling for short periods of time is not recommended. During a cold engine start-up, enough moisture is developed within the engine and the exhaust system to create a corrosion hazard that could affect the future operation of the Pacbrake. The brake housing may trap water in the valve shaft bore causing corrosion in an improper or nonfunctioning brake. If it is necessary to periodically start



**Fig. 7.6, Pacbrake Exhaust Brake and Air Cylinder**

the engine, it is recommended that normal operating temperatures be attained before shutting down the engine.

## Allison World Transmission

Pacbrake exhaust brakes on engines that are used with the Allison World Transmission MD series, are interfaced with the transmission electronic control module (ECM). An exhaust-brake-enabled transmission ECM will usually provide converter lockup in gears two through six. Effective exhaust braking begins when the transmission automatically downshifts into fifth gear (62 mph or less). Once on, the Pacbrake exhaust brake will control road speed and/or slow the vehicle sufficiently that the transmission will automatically downshift, if necessary, to Allison's preselect mode.

The preselect mode is normally assigned to second gear; however, the transmission can be reprogrammed by an Allison Transmission Distributor to third or fourth gear should the operator desire. If additional retarding power is required before the automatic downshifting occurs, you can select a lower transmission gear on the Allison shift selector.

## Engine Braking System, Optional

### Mercedes-Benz Engine Brake/ Constant-Throttle Valves

To increase braking performance, the MBE900 engine can be equipped with constant throttles in each combustion chamber. Small valves built into the cylinder head allow a small amount of compressed air to escape through the exhaust port during the combustion stroke. The constant-throttle valves are open during the entire time that the engine brake is activated.

When a vehicle is equipped with both an exhaust brake and an engine brake, a three-position engine brake switch is used to apply the exhaust and/or engine brakes. When the top of the engine brake switch is pressed, both the engine brake and exhaust brakes are applied. Using the engine brake and exhaust brake provides the best braking performance. With the switch in the center position, only the exhaust brake is applied. When the bottom of the switch is pressed, the switch is off.

## Clutches

### General Information

The major reason clutches wear out too soon is excessive heat. Clutches are designed to absorb and dissipate more heat than encountered in typical operation. The temperatures developed in typical operation will not break down the clutch friction surfaces. However, if a clutch is slipped excessively or required to do the job of a fluid coupling, high temperatures develop quickly and destroy the clutch. Temperatures generated between the flywheel, driven discs, and pressure plates can be high enough to cause the metal to flow and the friction facing material to char and burn.

### CAUTION

**Do not allow sustained slippage of the clutch; this could severely damage the clutch disc, pressure plate, or flywheel. Damage caused by clutch slippage due to improper break-in is not warrantable.**

Slipping and excessive heat are practically nonexistent when a clutch is fully engaged. But during the

moment of engagement, when the clutch is picking up the load, it generates considerable heat. An incorrectly adjusted or slipping clutch will rapidly generate sufficient heat to destroy itself.

The most important items that a driver should be aware of to ensure long service life of the clutch include: starting in the right gear, recognizing clutch malfunctions, and knowing when to adjust a clutch.

## Clutch Operation

### Gear Shifting Techniques

Many drivers upshift into the next gear or even skip-shift into a higher gear before the vehicle has reached the correct speed. This type of shifting is almost as bad as starting off in a gear that is too high since the engine rpm and vehicle speeds are too far apart, requiring the clutch to absorb the speed difference by generating heat. For transmission operating instructions, see [Chapter 8](#).

Apply the clutch brake by fully depressing the clutch pedal. The purpose of the clutch brake is to stop the transmission gears from rotating in order to engage the transmission gears quickly in making an initial start.

---

## CAUTION

---

**Never apply the clutch brake when making downshifts or upshifts. The clutch pedal should never be fully depressed before the transmission is put in neutral. If the clutch brake is applied with the transmission still in gear, a reverse load will be put on the gear. At the same time, it will have the effect of trying to stop or decelerate the vehicle with the clutch brake. Rapid wear of the friction discs will take place necessitating frequent replacement. Considerable heat will be generated, which will be detrimental to the release bearings and transmission front bearings.**

### Vehicle Overload, or Overloading the Clutch

Clutches are designed for specific vehicle applications and loads. These limitations should not be exceeded.

---

## CAUTION

---

**Overloading will not only result in damage to the clutch, but also to the entire powertrain.**

### Riding the Clutch Pedal

Riding the clutch pedal is destructive to the clutch since partial clutch engagement permits slippage, generating excessive heat. Riding the clutch pedal will also put a constant thrust load on the release bearing which can thin out the lubricant. Release bearing failures can be attributed to this type of misuse.

### Holding the Vehicle on an Incline With a Slipping Clutch

A slipping clutch accumulates heat faster than it can be dissipated, resulting in early clutch failures. Never use the clutch as a hill holder.

### Coasting With the Clutch Released (Pedal Depressed) and the Transmission in Gear

Do not allow the vehicle to coast with the clutch released and the transmission in gear. If the transmission remains in a low gear and the vehicle gains speed, which may occur on a downgrade, the input shaft and clutch driven disc will turn at speeds that are higher than normal. This occurs because the rear wheels and the driveline become the input for the transmission, and a higher-than-normal speed for a given transmission gear translates to a higher rpm value for the clutch driven disc.

## WARNING

**Do not coast with the clutch released (pedal depressed) and the transmission in gear. High driven-disc rpm could cause the clutch facing to be thrown off the disc. Flying debris could cause injury to persons in the cab.**

### Engaging the Clutch While Coasting

Engaging the clutch while coasting can result in tremendous shock loads and possible damage to the clutch as well as to the entire drivetrain.

# Engines and Clutches

---

## Reporting Erratic Clutch Operation Promptly

Reporting erratic clutch operation as soon as possible will give maintenance personnel a chance to inspect the clutch components.

On mechanical clutch linkages, free-pedal travel should be included and commented on daily in the driver's report, since clutch free-pedal travel is the maintenance department's guide to the condition of the clutch and the release mechanism.

### CAUTION

**Operating the vehicle with incorrect clutch pedal free-travel could result in clutch damage. See Group 25 of the *Acterra® Workshop Manual* for free-pedal adjustment procedures and specifications.**

## Clutch Adjustments

Some clutches have an internal adjustment. See the applicable section in **Group 25** of the *Acterra® Workshop Manual* for clutch adjustment procedures and specifications.

### CAUTION

**Operating the vehicle with the clutch incorrectly adjusted could result in clutch or clutch brake failure.**

## Lubrication

The release bearing should be lubricated at frequent intervals. See **Group 25** of the *Acterra® Maintenance Manual* for intervals and procedures.

### CAUTION

**Failure to lubricate the release bearing as recommended could result in release bearing damage and damage to the clutch.**



# 8

## Transmissions

---

Freightliner SmartShift Shift Control .....	8.1
Eaton Fuller AutoShift Automated Transmissions .....	8.1
Eaton Fuller UltraShift™ .....	8.5
Eaton Fuller Straight-Shift Transmissions .....	8.10
Eaton Fuller Range-Shift Transmissions .....	8.11
Eaton Fuller Deep-Reduction Transmissions .....	8.13
Mercedes-Benz Manual Transmissions .....	8.15
TTC Manual Transmissions .....	8.16
Allison On-Highway Transmissions .....	8.16
Allison MD Series Transmissions .....	8.19
Allison AT/MT Series Transmissions .....	8.22
Mercedes-Benz Automated Transmissions .....	8.24

# Transmissions

## Freightliner SmartShift Shift Control

The SmartShift transmission control is an electronic transmission control device. It is installed with the following transmissions:

- Eaton® Fuller® AutoShift™
- Eaton Fuller UltraShift™
- Mercedes-Benz Automated Gear Shift (AGS)

It replaces either the typical floor-mounted shift lever or dash-mounted push button control.

SmartShift accepts driver requests for transmission functions and transmits them through hard wiring to the transmission control unit (TCU). SmartShift is a true shift-by-wire system.

SmartShift offers two main advantages over conventional transmission control devices. Without a floor-mounted shift control, usable cab space is increased. The SmartShift control mounts to the right-hand side of the steering column and is operated by the fingers of the driver's right hand, allowing both hands to remain on the steering wheel.

A two-position slide switch (Fig. 8.1) is mounted on the body of the control lever just before the paddle widens out. The slide switch allows the driver to choose automatic (AUTO) or manual (MAN) mode.

In AUTO mode, gears shift automatically, without driver interaction. Manual gear shifts are accomplished by a momentary pull or push on the control in the plane perpendicular to the steering wheel. Pull upward (toward you) on the control to upshift and push downward (away from you) to downshift. The control is spring-loaded and returns to mid-position when released after an upshift or downshift.

For the Eaton Fuller automated transmissions (Fig. 8.1), a four-position (R, N, D, L) selector switch is located at the end of the lever. For the Mercedes-Benz AGS (Fig. 8.2), a three-position (R, N, D) selector switch is located at the end of the lever.

Embedded in the selector switch is a small neutral lock button to prevent accidental shifts into gear from neutral. Any time you shift through N, press down on the neutral lock button to move the switch from neutral (N) to another gear, such as drive (D), low (L), or reverse (R). When shifting to N, it is not necessary to press the neutral lock button.

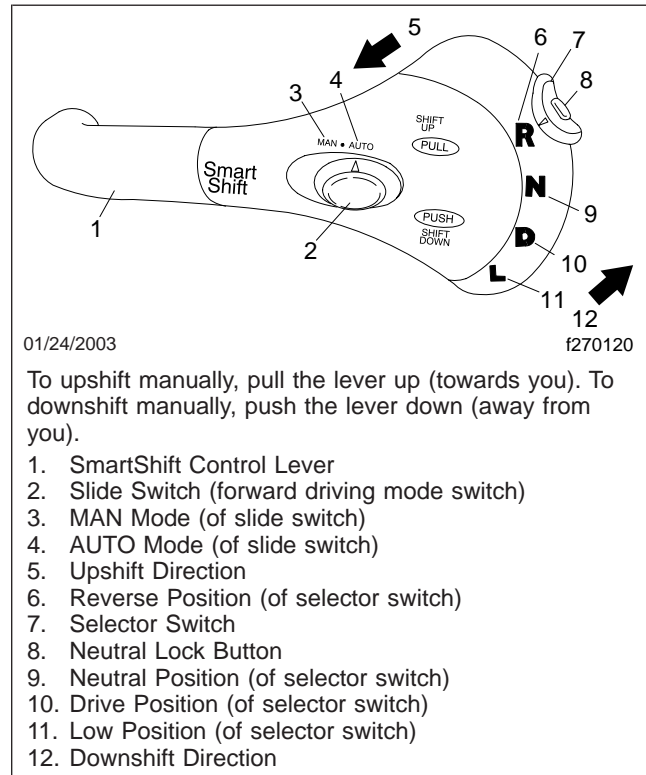


Fig. 8.1, SmartShift Control (with Eaton Fuller AutoShift and UltraShift)

## Eaton Fuller AutoShift Automated Transmissions

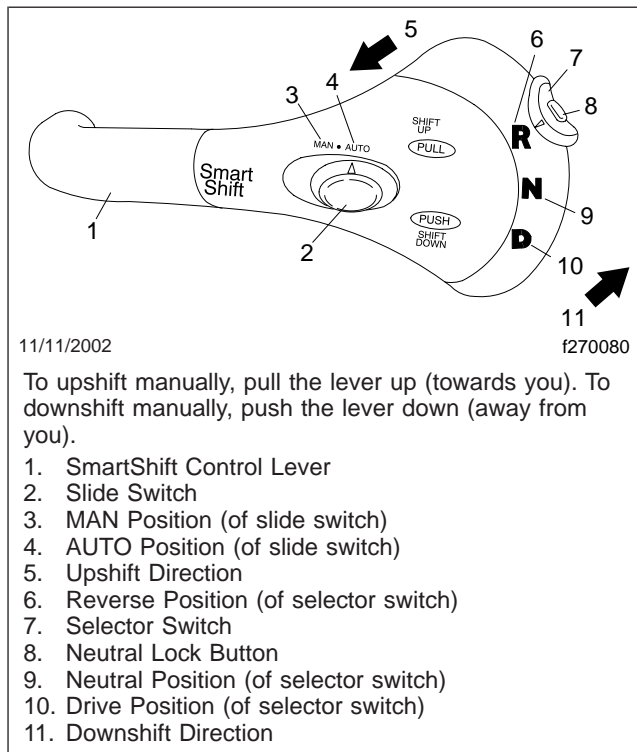
Refer to the Eaton website for additional information, [www.roadranger.com](http://www.roadranger.com).

**IMPORTANT:** Before starting the vehicle, always do the following:

- Be seated in the driver's seat.
- Place the transmission in neutral.
- Set the parking brakes.
- Press the clutch pedal down to the floor.

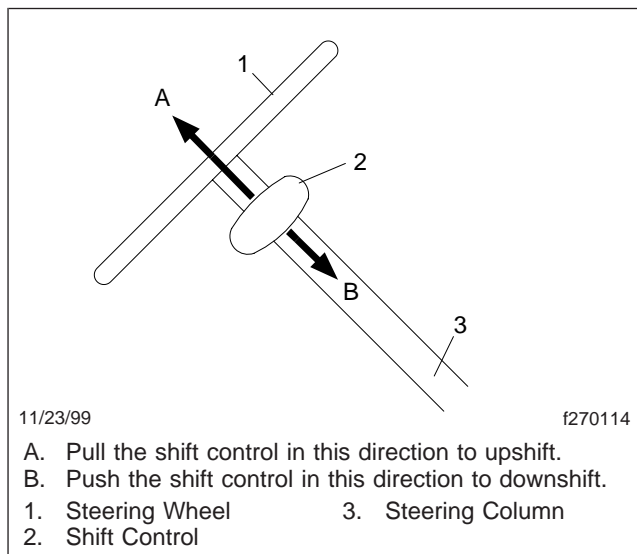
## General Information, AutoShift

The AutoShift ASX is a partially automated 6-speed or 7-speed Eaton Fuller transmission. The AutoShift AS2 is a partially automated 10-speed Eaton Fuller transmission. On all models, the driver must use the clutch and put the transmission in neutral to start and



**Fig. 8.2, SmartShift Control (with Mercedes-Benz AGS)**

stop the vehicle. The SmartShift transmission shift control (**Fig. 8.3**) is used with the AutoShift transmission.

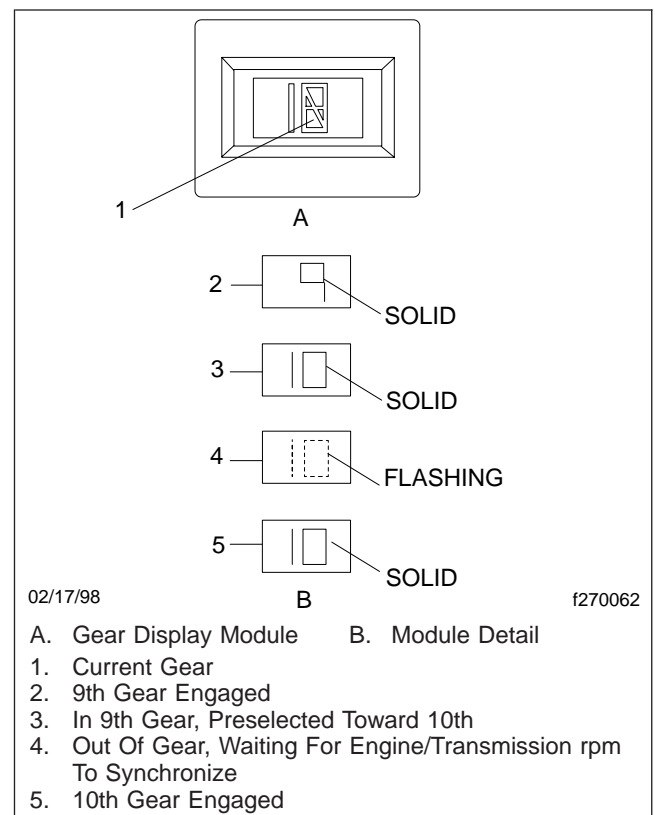


**Fig. 8.3, SmartShift Control Operation**

The driver does not need to break torque or increase or decrease engine speed to synchronize the shift. The transmission signals the engine controller when to break torque and the engine controller automatically increases or decreases engine speed. When engine speed is correct, the transmission engages the next gear and signals the engine controller to resume operation.

The AutoShift transmission can be operated in an automatic (AUTO) mode or a manual (MAN) mode. Select the mode you want to use by moving the slide switch on the shift control.

Gear information is presented to the driver on a gear display module mounted on the dashboard (**Fig. 8.4**). In automatic mode, the number of the forward gear currently selected appears continually on the display when in drive.



**Fig. 8.4, Gear Display Module**

The display also flashes the next gear to be engaged while the transmission is in neutral during a gear

# Transmissions

---

change. In manual mode, the current gear is displayed until a new gear is requested. When neutral is selected, N will appear on the display.

If the gear display continues to flash after releasing the clutch pedal, gear engagement is not complete. Press down the clutch again and wait for the gears to fully engage.

When reverse (R) is engaged on 10-speed AutoShift transmissions, either "RL" or "RH" will appear on the message display screen. AutoShift transmissions with fewer speeds do not have a dual range reverse gear. "R" will appear when reverse is engaged.

**IMPORTANT:** The information shown on the digital display indicates the state of the transmission only, not the state of the SmartShift control.

## Operation, SmartShift With Eaton Fuller AutoShift

 **WARNING**

**If the engine cranks in any gear other than neutral, have the vehicle serviced immediately. If the vehicle is started in gear it will suddenly move forward or backward, which could result in personal injury and damage to property and the transmission.**

### Automatic and Manual Modes

A two-position slide switch (forward driving mode switch) is located near the end of the control. See [Fig. 8.1](#). The switch positions are labelled MAN (manual shift mode) and AUTO (automatic drive mode).

**NOTE:** In automatic drive mode, upshifts and downshifts require no driver interaction. Move the selector switch to the drive (D) position, disengage the clutch to engage the gear selected, engage the clutch and drive the vehicle. In manual shift mode, upshifts and downshifts require either a pull upward or push downward on the control.

### Start-Up

1. With the parking brake applied, press the clutch all the way down to the floor.

2. Check to make sure the transmission is in neutral.

**IMPORTANT:** To start the engine, the transmission must be in neutral.

3. Start the engine.
4. With the transmission in neutral, release the clutch pedal.

**NOTE:** This allows the speed sensor on the input shaft to get a reading.

5. Press down on the clutch again and release the parking brake.
6. Select the desired starting gear.
7. Release the clutch.

**IMPORTANT:** If you have to leave the cab with the engine running:

- Place the transmission in neutral.
- Set the parking brakes.
- Chock the tires.

### Reverse

1. To engage reverse (R), slide the selector switch upward to the next position above the neutral position and disengage the clutch.

**NOTE:** AutoShift 10-speed transmissions have a dual-range reverse. Reverse low (RL) is the default reverse gear.

2. Select reverse high (RH) by pulling upward on the control.

**NOTE:** Reverse may be engaged below a programmable forward speed in order to rock the vehicle. If reverse is selected above the programmed forward speed, an audible warning will sound and a message indicating that the gear is not available will appear on the message display screen.

### Neutral

Neutral (N) is used for starting, parking, or any stationary operation. No gear is selected. The transmission must be in neutral before the engine can be started.

Select neutral by moving the mode selector switch to N while depressing the clutch pedal. Verify that the letter N appears on the auxiliary display. Set the parking brakes and slowly release the clutch pedal.

**NOTE:** Neutral is always available during vehicle operation. When in neutral, upshift and downshift requests are ignored. If the mode selector switch is moved from N to D (drive) while the vehicle is moving, the transmission will select an appropriate gear for the road speed.

## Selecting a Starting Gear

1. In automatic mode, select drive (D) by sliding the selector switch downward to the next position below the neutral position.
2. Disengage the clutch to engage the gear selected. Engage the clutch and drive the vehicle.

**NOTE:** To select a starting gear other than the default starting gear, either pull upward or push downward on the control while the vehicle is stopped and in drive (either manual or automatic mode).

Each pull upward on the control increases the starting gear by one gear, but no higher than 4th gear. The number of the gear selected will flash on the message display screen until the driver engages the clutch.

This gear will be stored in memory as the default starting gear until either a different starting gear is selected by the driver or the engine is shut down. The transmission may also be programmed so that it is not possible to select a starting gear other than the preprogrammed default starting gear.

## Upshifting

In drive (D), the transmission selects the starting gear and automatically selects gears between the starting gear and the top gear.

1. To select drive, move the selector switch to D while depressing the clutch pedal. Slowly release the clutch pedal and drive the vehicle.

**NOTE:** With the transmission in drive (D) in the automatic mode, upshifts require no driver interaction.

2. With the transmission in drive in the manual mode, request an upshift by pulling upward on the control. See [Fig. 8.3](#). If the requested gear is available, the transmission will upshift.

**NOTE:** A single, momentary pull upward on the control selects the next higher gear when it is available. Two consecutive, momentary upward pulls will cause a skip shift when the next two higher gears are available and conditions are right.

3. To skip shift, move the control two times in less than 1/2 second. The number of the gear engaged will appear on the message display screen.

**NOTE:** If a requested gear is not available, an audible warning will sound and the message display screen will indicate that the gear is not available. An unavailable requested upshift is not stored in memory. The upshift must be requested again.

## Downshifting

**NOTE:** With the transmission in drive (D) in the automatic mode, downshifts require no driver interaction.

1. With the transmission in drive in the manual mode, request a downshift by pushing downward on the control. If the requested gear is available, the transmission will downshift.

**NOTE:** A single, momentary push downward on the control selects the next lower gear when it is available. Two consecutive, momentary downward pushes will cause a skip shift, when the next two lower gears are available and conditions are right.

2. To skip shift, move the control two times in less than 1/2 second. The number of the gear engaged will appear on the message display screen.

**NOTE:** If a requested gear is not available, an audible warning will sound and the message display screen will indicate that the requested gear is not available. Unlike upshifting, an unavailable requested downshift is stored in memory and the shift will be made when the

# Transmissions

gear is available. The time limit for this memory is a programmable parameter.

## Low Gear Operation

Use low (L) when descending steep hills and using compression braking. Engine speed will be increased by 200 rpm and shift points will be offset by 200 rpm. The efficiency of the exhaust brake will be maximized.

Select low by moving the mode switch selector while depressing the clutch pedal if the vehicle is stopped. If L is selected while the vehicle is moving, the transmission downshifts at the earliest opportunity for maximum engine braking.

## Using the Clutch

Use the clutch to start and stop the vehicle. Be sure to put the transmission in neutral and apply the parking brake before shutting down the engine.

## Eaton Fuller UltraShift™

### General Information, UltraShift ASW

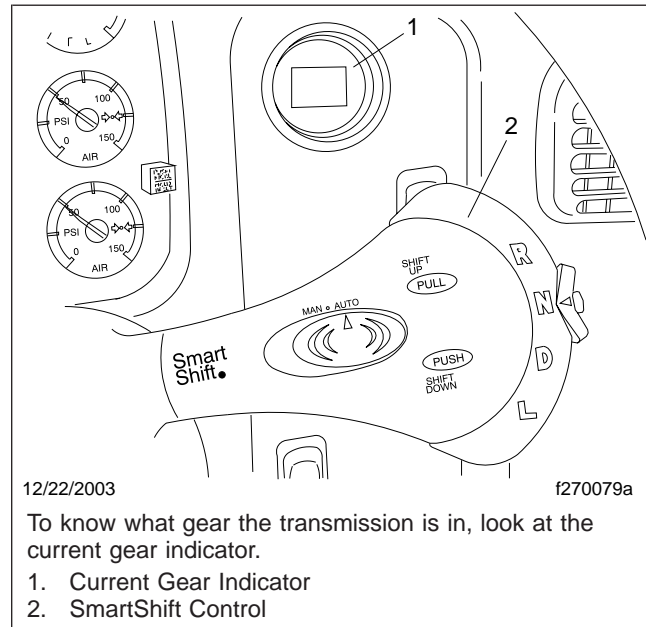
UltraShift ASW is a fully-automated six-speed medium-duty transmission. No clutch pedal is required to operate the vehicle. This transmission uses a "wet" clutch system in which the drive and driven discs rotate in a bath of automatic transmission fluid (Dexron III).

The UltraShift transmission uses the four-position SmartShift control lever on the steering column to select gears. To know what gear the transmission is in, look at the round current gear indicator on the right-hand control panel as shown in [Fig. 8.5](#). All forward shifts can be made either manually or automatically, at the driver's choice.

### Operation, UltraShift ASW

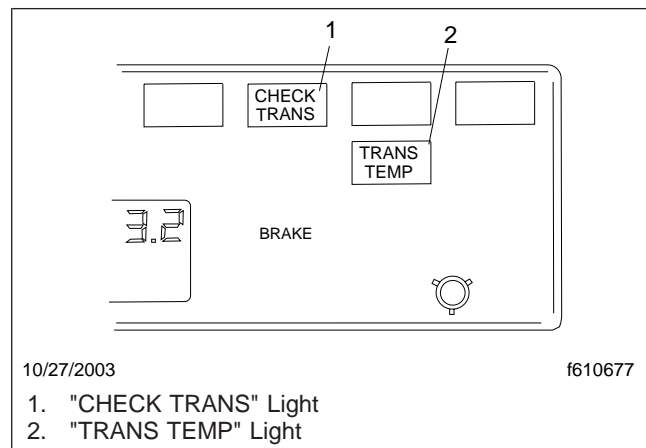
#### Power Up

1. With the parking brake set, select neutral (N) by moving the selector switch to the N position.
2. With the transmission in neutral, turn on the ignition switch. The "CHECK TRANS" and "TRANS TEMP" telltale lights come on and go out again (bulb check). See [Fig. 8.6](#).
3. After the ignition is turned on, the current gear indicator shows the dot display, arranged in a



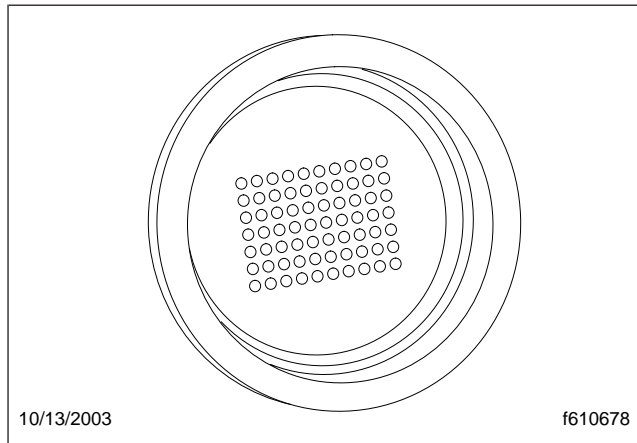
**Fig. 8.5, Shift Controls and Indicators, UltraShift Transmissions**

- To know what gear the transmission is in, look at the current gear indicator.
1. Current Gear Indicator
  2. SmartShift Control



**Fig. 8.6, Telltale Lights**

- square pattern. All dots in the pattern should light up, without gaps or spaces. See [Fig. 8.7](#).
4. Wait for the current gear indicator to show a solid "N." When the "N" is solid, rather than flashing, the UltraShift ASW transmission control unit (TCU) is powered up. Start the engine and apply the service brake.
5. Select drive (D) by pressing in the neutral lock button and moving the selector switch downward



**Fig. 8.7, Power Up Dot Display**

to the position below neutral. Release the parking brake. The gear is displayed on the current gear indicator.

**NOTE:** When D is selected, the transmission starts up in default starting gear, either first or second.

6. On a level grade, release the service brake and press down on the throttle pedal to allow the vehicle to move forward.

**⚠ WARNING**

**When starting or stopping on hills and grades, use extra care to prevent the vehicle from rolling back. A rollback accident could cause death, serious personal injury, or property damage.**

7. Prevent the vehicle from rolling backwards when stopped on a hill or grade, or when the vehicle is starting from a stop on a hill or grade.
  - 7.1 *To start from a full stop on hill or grade, quickly move your foot from the brake pedal and press firmly on the throttle pedal.*  
On steep hills, set the parking brake and release it only when there is enough engine power to prevent rollback.
  - 7.2 *To stop on a hill or grade, press and hold the brake pedal to keep the vehicle from moving.*

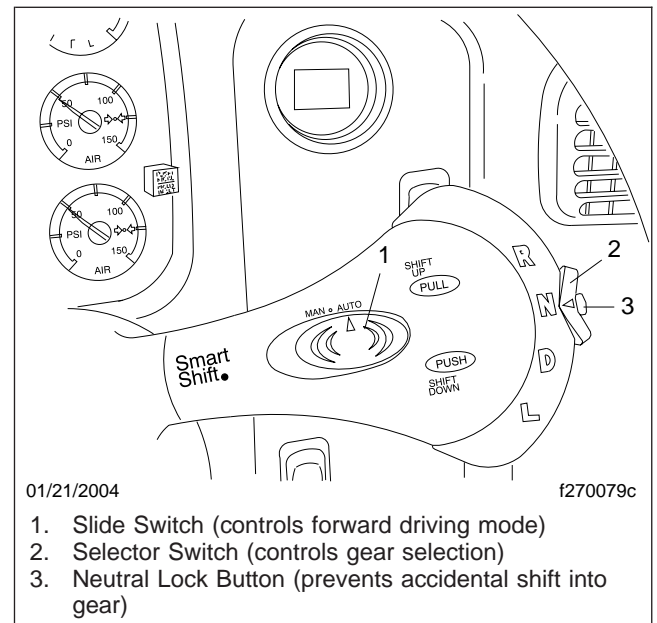
On steep hills, set the parking brake and chock the tires, front and/or rear. Never hold a hill with the throttle pedal. This will cause the clutch to overheat.

## Power Down

1. Apply the service brakes.
2. Select neutral (N) by moving the selector switch to N. When the "N" on the current gear indicator is solid, rather than flashing, the ASW TCU is ready to power down.
3. With the transmission in neutral, set the parking brake.
4. Turn off the ignition key and shut down the engine.

## Automatic and Manual Modes

The SmartShift control has a slide switch located on the body of the control lever just before the paddle widens out. See **Fig. 8.8**. The slide switch controls the forward driving mode, automatic or manual.



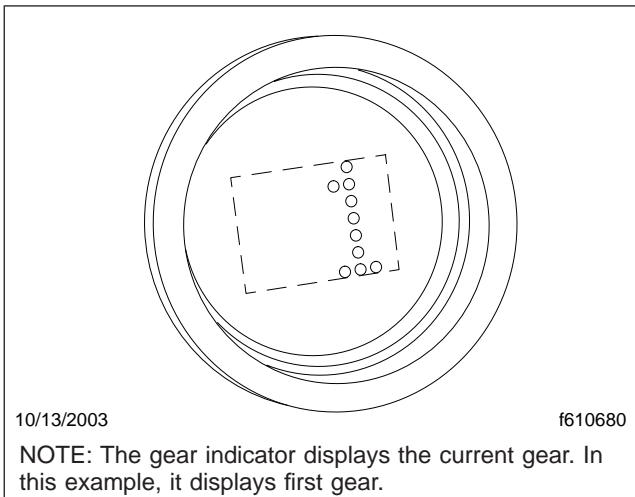
**Fig. 8.8, Switches, UltraShift Transmissions**

To change mode at any time, move the slide switch in the desired direction. This allows the driver to respond flexibly to a wide range of driving conditions, such as blind corners, tight curves, and steep hills.

# Transmissions

**IMPORTANT:** Whatever the mode, it is always possible to shift manually by moving the lever up or down as needed. When the engine speed is within 75 revolutions per minute (rpm) of the load-based shift point for an automatic shift, the ASW TCU will advance the shift.

In either mode, the gear indicator displays the current gear. See **Fig. 8.9**.



**Fig. 8.9, Current Gear Display**

At the start of a shift, the current gear continues to display until the transmission has been pulled into neutral. At this point, as the transmission is synchronizing for the new (target) gear, the gear indicator flashes the number of the new gear.

When the shift is complete, the new gear displays solid, without flashing.

## Automatic Mode (AUTO)

In automatic drive mode (AUTO), upshifts and downshifts are made by the transmission without driver intervention. Press in the neutral lock button, move the selector switch to drive (D), and press down on the throttle pedal. The transmission will shift automatically.

If driving conditions require, it is still possible to request a manual shift. The transmission will make the shift if the engine speed is within 75 rpm of the load-based shift point for that gear.

If the driver presses down on the throttle pedal after a manual downshift in automatic mode, the transmission will upshift again if the ASW TCU requires it.

## Manual Mode (MAN)

In manual drive mode (MAN), upshifts and downshifts are made by the driver:

- To shift up, pull the lever up (towards you).
- To shift down, push the lever down (away from you).

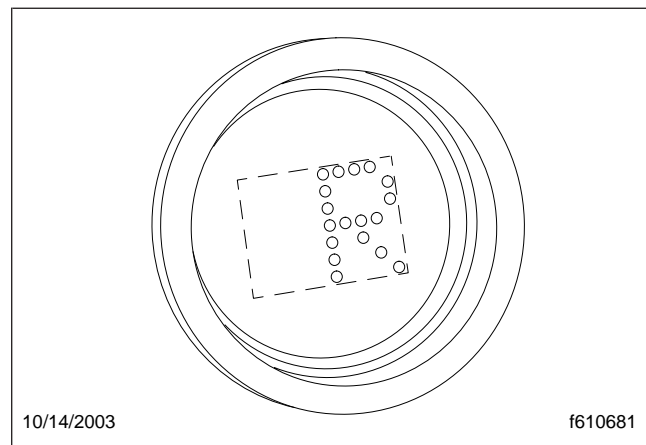
The system will hold the current gear until the driver requests a shift. In downhill situations in particular, the driver must be alert to vehicle speed by downshifting and/or using the service brakes as needed.

A shift request will still be refused if the selected gear would cause engine overspeed or excessive lugging.

## Selecting Gears

### Reverse

Reverse (R) is at the upper end of the four-position selector switch located at the end of the SmartShift control lever. To select R, press in the neutral lock button and move the selector switch upward to the position above neutral. When reverse is selected, the letter "R" displays on the current gear indicator. See **Fig. 8.10**.



**Fig. 8.10, Reverse Gear Display**

**IMPORTANT:** Under normal conditions, do not select reverse with the vehicle moving forward.

The vehicle must be moving at less than two miles per hour (3 km/h) before selecting reverse. If reverse

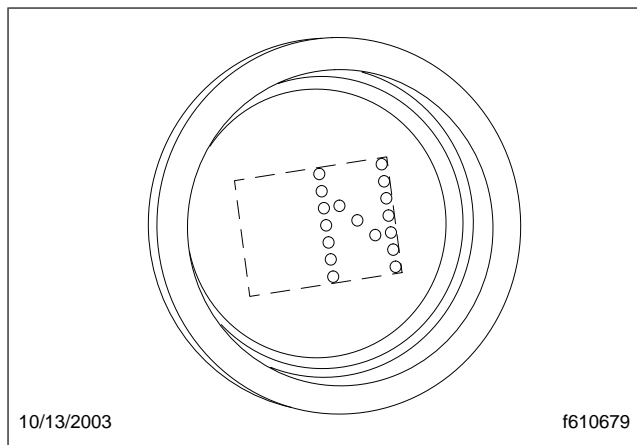


is selected when the vehicle is moving faster, an audible warning will sound and continue sounding at three-second intervals until the control lever is returned to the D position. When the vehicle is moving at the proper speed, reverse can be engaged.

## Neutral

**IMPORTANT:** Always start the engine with the transmission in neutral, the parking brake set, and the service brakes applied.

Neutral (N) is directly below R on the four-position selector switch located at the end of the SmartShift control lever. To select N, move the selector switch to the position below R. When neutral is selected, the letter "N" displays on the current gear indicator. See **Fig. 8.11**.



**Fig. 8.11, Neutral Display**

## **WARNING**

**Do not coast in neutral. Coasting in neutral can cause an accident, possibly resulting in severe personal injury or death.**

Neutral is always available during operation, whatever the vehicle speed. When in neutral, requests to upshift or downshift are ignored. If the selector switch is moved from neutral to drive while the vehicle is moving, the transmission will shift into a gear within the engine's operating torque range.

Before shutting down the engine, return the selector switch to N. When the ignition is turned off, the transmission will reset to neutral in a few minutes regardless of the position of the shift lever.

## Drive

Drive (D) is directly below N on the four-position selector switch located at the end of the SmartShift control lever. To select D, press in the neutral lock button and move the selector switch to the position below N. When drive is selected, the number of the currently selected forward gear (1, 2, 3, 4, 5, or 6) displays on the gear indicator. See **Fig. 8.9**.

When in drive, requests to upshift or downshift are enabled. Either manual or automatic mode can be selected on the slide switch.

The vehicle starts up in either first or second gear, depending on load and grade.

The ASW UltraShift controller adapts to the working conditions of each vehicle and its driver. After power up or a load change, it needs to learn the new conditions. While learning, it may hold a gear too long before upshifting. Start the upshift manually. It may take three or four shifts before ASW succeeds in learning the new load-based shift points, but after that it will handle the shifting automatically.

## Low

Low (L) is located at the lower end of the four-position selector switch located at the end of the SmartShift control lever. To select L, press in the neutral lock button and move the selector switch to the position below D.

When in low, the current gear is maintained. Requests to upshift are not enabled.

**IMPORTANT:** If the engine is approaching overspeed, the ASW TCU will override the current gear setting and upshift to prevent engine damage.

To enhance engine braking, downshifts are performed at higher rpm than normal.

If L is selected from neutral while stopped, the vehicle starts up in first gear and stays there until the engine approaches overspeed.

## Upshifting

To request an upshift with the transmission in drive, pull the control lever up (towards you). If the gear is available, the transmission upshifts and the new gear displays on the gear indicator. No skip shifts are available while upshifting.

# Transmissions

---

No upshifts are available in low, except to prevent engine overspeed.

If the transmission does not upshift quickly enough after power-up or a load change, begin the shift manually. The ASW TCU will learn the new load-based shift conditions after three or four shifts.

If the gear requested is unavailable, a tone will sound. An unavailable request to upshift is not stored in memory. The upshift must be requested again.

## Downshifting

**NOTE:** The driver can manually downshift at any time, even when the slide switch is set to AUTO mode.

To request a downshift with the transmission in drive or low, push the control lever down (away from you). If the gear is available, the transmission downshifts and the new gear displays on the gear indicator. Skip shifts are available while downshifting.

For best engine braking, select low while moving. In low, downshifts are performed at higher rpm than in drive.

**IMPORTANT:** If the engine is approaching overspeed, the ASW TCU will override the current gear setting and upshift to prevent engine damage.

If the gear requested is unavailable, a tone will sound. An unavailable request to downshift is not stored in memory. The downshift must be requested again.

When coasting to a stop, the ASW TCU does not finish the downshift until the driver presses down on the throttle pedal again.

**IMPORTANT:** A downshift request can never result in a shift into neutral, even if the vehicle is in the drive position in the lowest possible gear.

Before starting down a hill, slow down. Downshift to a speed that you can control without hard pressure on the service brakes.

Before entering a curve, slow down to a safe speed. Downshift if necessary. This lets you use some power through the curve to help the vehicle be more stable on the turn. It also allows you to regain speed faster as you come out of the curve.

## Ultrashift Diagnostics

### Clutch Calibration

The ASW TCU automatically adjusts for clutch wear. The calibration takes place whenever the following conditions are met:

- The engine is at normal operating temperature
- The vehicle is stopped
- The engine is at idle speed
- The selector switch on the controller is in neutral

Calibration may take up to two minutes to complete. The engine may slow and return to normal idle several times during calibration.

To stop calibration at any time, select one of the drive positions on the selector switch (R, D, or L).

### Clutch Protection Fault

Excessive clutch slippage creates heat and reduces the life of the clutch. These are some conditions which lead to clutch abuse:

- Using the throttle to hold the vehicle on a grade
- Starting the vehicle in too high a gear
- Overloading the vehicle
- Using high idle with the vehicle in gear

The ASW TCU is programmed to prevent clutch abuse. When the clutch overheats, the following alerts take place:

- The "TRANS TEMP" light comes on
- The current gear indicator displays "CA"
- A warning tone sounds at one-second intervals

The alerts continue until the clutch cools, the throttle is released, or the clutch is fully engaged.

### System Problem

In the event of a problem, do the following steps:

1. Note the driving conditions at the time the problem occurred.

- Record the status of the transmission at the time of the problem (AUTO or MAN mode, gear setting R, N, D, or L, current gear, engine speed, etc.)
- Reset the system, using the procedure below.

## Reset Procedure

Transmission operation can sometimes be restored by doing the following reset procedure:

- Stop the vehicle when it is safe to do so. Set the parking brake.
- Place the selector switch in neutral and turn off the ignition.
- Check all harness connectors as described in [Chapter 11](#).
- Wait at least two minutes with the engine shut down.
- Restart the engine.

If the problem continues, contact an authorized Freightliner or Eaton service facility.

## Locked In Gear

If the transmission becomes locked in gear, a dash (-) will appear on the current gear indicator when the vehicle is restarted during the reset procedure.

**NOTE:** If the transmission becomes locked in gear while the vehicle is moving, increased braking effort may be required to stop the vehicle.

If the current gear indicator displays a dash during power-up with the selector switch in neutral, do the following steps:

- Make sure the parking brake is set. Turn off the ignition and wait at least two minutes.
- Apply the service brakes.
- With the service brakes applied, release the parking brake.
- Make sure the selector switch is in neutral and turn on the ignition key. Do not attempt to start the engine at this time.
- If necessary to get the transmission to shift into neutral, release the pressure on the brake pedal slightly.

- Once the ASW TCU reaches neutral, a solid "N" will appear on the current gear indicator and the vehicle will start. Make sure the service brakes are applied and the parking brake is set.

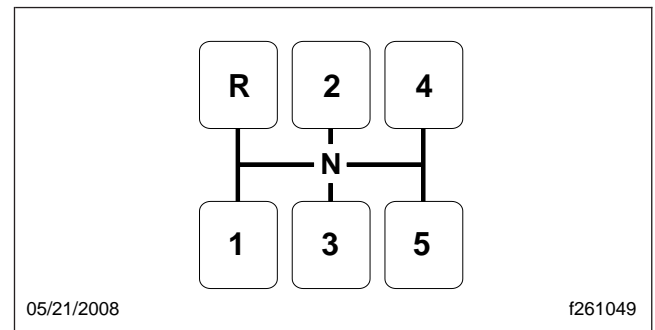
If the current gear indicator continues to display a dash, contact an authorized Freightliner or Eaton service facility.

## Eaton Fuller Straight-Shift Transmissions

Refer to the Eaton website for additional information, [www.roadranger.com](http://www.roadranger.com).

### General Information, Straight-Shift

Eaton Fuller 5-speed FS models are fully synchronized. They have five forward speeds and one reverse. See [Fig. 8.12](#) for the shift pattern.



**Fig. 8.12, Shift Pattern, 5-Speed FS Models**

Eaton Fuller 6-speed FS and FSO models are fully synchronized. They have six forward speeds and one reverse. See [Fig. 8.13](#) for the shift pattern.

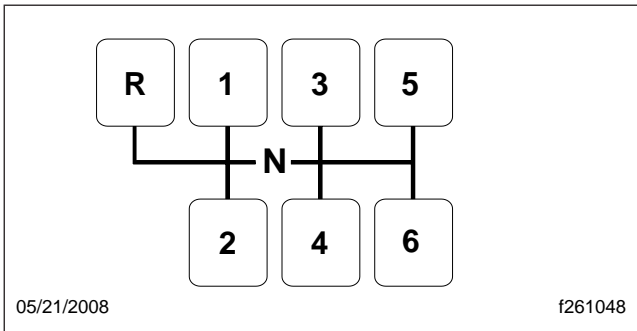
Eaton Fuller 7-speed T models are not synchronized. They have seven forward speeds and one reverse. See [Fig. 8.14](#) for the shift pattern.

These transmissions are designed for use with on-highway, fuel economy engines where a minimum of shifting is desired and less gear reduction is acceptable.

### Operation, Straight-Shift

- Always use 1st gear when starting to move the vehicle forward.
- Accelerate to build up the engine speed (rpm) needed to shift into 2nd gear. Disengage the

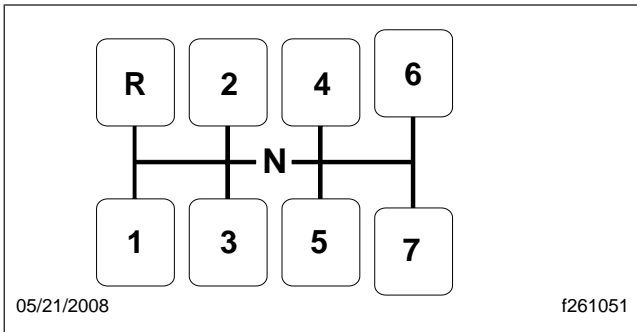
# Transmissions



05/21/2008

f261048

Fig. 8.13, Shift Pattern, 6-Speed FS and FSO Models



05/21/2008

f261051

Fig. 8.14, Shift Pattern, 7-Speed T Models

clutch and move the shift lever to 2nd gear. Engage the clutch and accelerate again. This is known as progressive shifting.

3. Continue upshifting using the same progressive sequence described in the previous step. Follow the pattern on the shift lever.
4. When downshifting, shift progressively down through each successive lower gear as follows:

When the engine speed drops to the same rpm to which it fell immediately after upshifting to that same gear, press the clutch pedal down and move the shift lever to the next lower gear. Engage the clutch smoothly.

Continue downshifting as required using the same sequence described above.

## CAUTION

If the vehicle is moving when shifting, depress the clutch pedal just far enough to disengage the clutch. Pressing it to the floor will engage the clutch brake, if so equipped, causing premature clutch brake wear.

**IMPORTANT:** Do not rest your foot on the clutch pedal while driving. This causes partial clutch disengagement which could cause premature clutch wear.

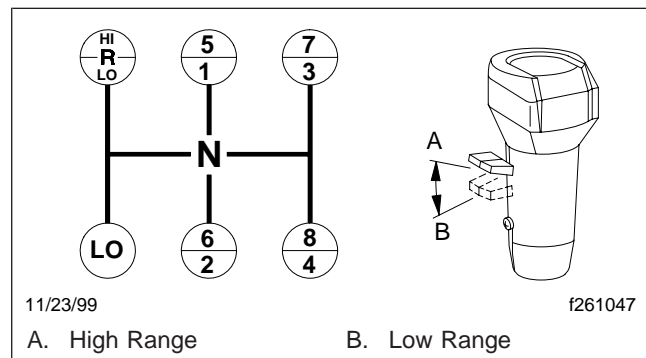
**NOTE:** On synchronized models, disengage the clutch completely when shifting gears. Double-clutching is unnecessary. On unsynchronized models, use double-clutching to engage 1st gear or reverse.

## Eaton Fuller Range-Shift Transmissions

Refer to the Eaton website for additional information, [www.roadranger.com](http://www.roadranger.com).

### General Information, Range-Shift Eaton Fuller 9-Speed RT Models

Eaton Fuller 9-speed RT models have nine forward speeds and two reverse speeds, consisting of a 5-speed front section and a 2-speed auxiliary section. The first position in the front section is used only as a starting gear. The other four ratios are used once in LO range and once again in HI range. See Fig. 8.15 for the shift patterns.



11/23/99

f261047

A. High Range

B. Low Range

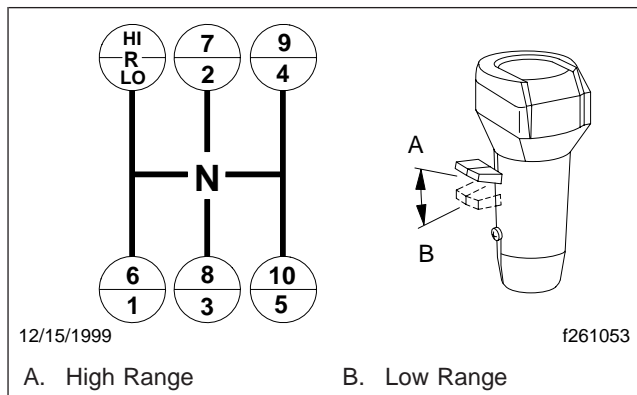
Fig. 8.15, Shift Pattern, 9-Speed RT Models

After shifting out of the first position, use the Roadranger® repeat H shift pattern. LO range and HI range are selected with the range knob or range lever. It is used once during the upshift sequence and once during the downshift sequence.

Always preselect the range shift. After preselection, the transmission will automatically make the synchronizer range shift as the shift lever passes through neutral.

## Eaton Fuller 10-Speed RT Models

Eaton Fuller Roadranger 10-speed RT and FR models have ten forward speeds and two reverse speeds. The gear shift lever mechanically engages and disengages five forward gears and one reverse gear in the transmission front section. The range lever on the roadranger valve allows the driver to control an air shifted auxiliary section to provide a LO and HI range. The five forward gears selected in LO range are used again in HI range to provide the 10 progressive forward gear ratios. See Fig. 8.16 for the shift patterns. See Table 8.1 for the shift progressions.



**Fig. 8.16, Shift Pattern, 10-Speed RT and FR Models**

Eaton Fuller Shift Progressions			
Model	LO Range		HI Range
	Off-Highway	On-Highway	
9-Speed Direct or Overdrive (RT)			
10-Speed Direct or Overdrive (RT)			

**Table 8.1, Eaton Fuller Shift Progressions**

Once the highest shift lever position (5th gear) is reached in LO range, the driver preselects the range

shift lever for HI range. The range shift occurs automatically as the shift lever is moved from 5th gear position to the 6th gear position.

When downshifting, the driver preselects the range lever for LO range and the range shift occurs automatically during the shift lever movement to the next gear position.

## Operation, Range-Shift

1. When operating off-highway or under adverse conditions, always use the low gear when starting to move the vehicle.

When operating on-highway, with no load or under ideal conditions, use 1st gear when starting to move the vehicle.

For all conditions, use the highest gear that is still low enough to start the vehicle moving with the engine idling and without excessively slipping the clutch.

2. Use the clutch brake to stop gear rotation when shifting into low (or 1st) or reverse when the vehicle is stationary. The clutch brake is applied by depressing the clutch pedal all the way to the floor.

For normal upshifts and downshifts, only a partial disengagement of the clutch is necessary to break engine torque.

3. Do not make range shifts with the vehicle moving in reverse gear.
4. Never attempt to move the range preselection lever with the gear shift lever in neutral while the vehicle is moving. Preselection with the range preselection lever must be made prior to moving the shift lever out of gear into neutral.
5. Do not shift from high range to low range at high vehicle speeds.
6. Double-clutch between all upshifts and downshifts.
7. After your shifting ability improves, you may want to skip some of the ratios. This may be done only when operating conditions such as load, grade, and road speed permit.

# Transmissions

---

## Upshifting

1. Position the gear shift lever in neutral. Start the engine and bring the air system pressure up to 100 to 120 psi (689 to 827 kPa).
2. Position the range preselection lever down into low range.
3. Press the clutch pedal to the floor. Shift into low or 1st gear, then engage the clutch with the engine at or near idle speed to start the vehicle moving. Accelerate to 80 percent of engine governed speed.
4. Shift progressively up from low or 1st gear to the top gear in low range, double-clutching between shifts and accelerating to 80 percent of engine governed speed.
5. While in the top gear of the low-range shift pattern and ready for the next upshift, flip the range preselection lever up into high range. Double-clutch through neutral and shift into the bottom gear in high range. As the shift lever passes through neutral, the transmission will automatically shift from low range to high range.
6. With the transmission in high range, shift progressively up through each of the high range gears, double-clutching between shifts.

## Downshifting

1. With the transmission in high range, shift progressively down to the bottom gear in high range, double-clutching between shifts.
2. When in the bottom gear of the high-range shift pattern and ready for the next downshift, push the range preselection lever down into low range. Double-clutch through neutral and shift into the top gear of the low-range shift pattern. As the shift lever passes through neutral, the transmission will automatically shift from high range to low range.
3. With the transmission in low range, downshift through the low range gears as conditions require.

Never use the clutch brake when downshifting or as a brake to slow the vehicle.

## Eaton Fuller Deep-Reduction Transmissions

Refer to the Eaton website for additional information, [www.roadranger.com](http://www.roadranger.com).

### General Information, Deep Reduction

**IMPORTANT:** Not all lever positions are used in each range and the shift patterns vary between transmissions. Be sure to read the shift pattern decal on the dash for the operating instructions for the specific transmission installed in your vehicle.

### 9-Speed RT–L Models

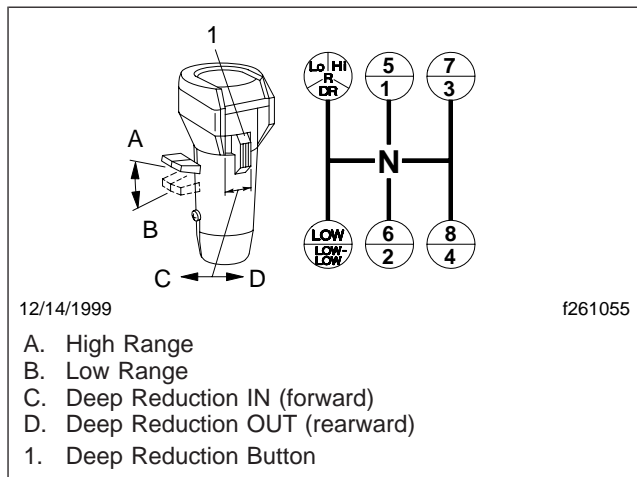
Eaton Fuller 9-speed deep-reduction transmissions have a 5-speed front section, and a 2-speed rear-range section, with a deep reduction button. The deep reduction (low-low) gear is used only when operating under adverse conditions. Low gear in the front section is used only for rough, off-highway conditions, as a starting ratio. Both the low gear and 1st gear in the low range can be split, using the deep reduction button, for another reduction ratio in those shift lever positions. The remaining four forward positions are used once in the low range and once in the high range. Reverse in the low range can also be split with the deep reduction button for a lower ratio.

### 10-Speed RT–LL Models

Eaton Fuller 10-speed deep-reduction transmissions have a 5-speed front section, and a 2-speed rear range section, with a deep reduction button. The deep reduction (low-low) gear is used only when operating under adverse conditions. Low gear in the front section is used only for rough, off-highway conditions, as a starting ratio. The remaining four forward positions are used once in the low range and once in the high range. See **Fig. 8.17** for the shift pattern.

### Operation, Deep Reduction

**IMPORTANT:** The shifter knob has an interlock feature that prevents the deep reduction button from being moved forward when the range preselection lever is up (in high range); when in low range and the deep reduction button is in the



**Fig. 8.17, Eaton Fuller 10-Speed Deep-Reduction Transmission Shift Patterns**

forward position, the range preselection lever cannot be moved up.

1. For all driving conditions, use the highest gear that is still low enough to start the vehicle moving with the engine idling, and without slipping the clutch excessively.
2. Use the clutch brake to stop gear rotation when shifting into low-low, low-1st (whichever is used as a starting ratio) or reverse, when the vehicle is stationary. The clutch brake is actuated by depressing the clutch pedal all the way to the floor.

For normal upshifts and downshifts, only a partial disengagement of the clutch is necessary to break engine torque.

3. Double-clutch between all upshifts and downshifts.
4. Never move the shift lever into low gear while in high range.
5. Do not preselect with the deep reduction button. When making the shift from a deep reduction ratio to a low range ratio, move the deep reduction button from a forward position to a rearward position, then complete the shift immediately.
6. Never move the deep reduction button from a rearward position to a forward position when the transmission is in high range.
7. Do not shift from high range to low range at high vehicle speeds.

8. Do not make range shifts with the vehicle moving in reverse gear.
9. Never attempt to move the range preselection lever with the gear shift lever in neutral while the vehicle is moving. Preselection with the range preselection lever must be made prior to moving the shift lever out of gear into neutral.
10. After your shifting ability improves, you may want to skip some of the ratios. This may be done *only* when operating conditions permit, depending on the load, grade, and road speed.

## Upshifting

There are several patterns of upshifting, depending on the vehicle load and the road conditions. Deep reduction gears are best suited for heavy loads and steep inclines. Low gear (in 10-speed transmissions) is best suited for off-highway use.

The following instructions are recommended for starting a loaded vehicle moving, under adverse conditions.

1. Position the gear shift lever in neutral. Start the engine, and bring the vehicle air system pressure up to 100 to 120 psi (689 to 827 kPa).
2. Position the range preselection lever down, into low range.
3. Move the deep reduction button to the forward position, to engage the deep reduction gears.
4. Depress the clutch pedal to the floor; shift into low-low gear; then engage the clutch, with the engine at or near idle speed, to start the vehicle moving. Accelerate to 80 percent of engine governed speed.
5. When ready for the next upshift, move the deep reduction button rearward, then break the torque on the gears by momentarily releasing the accelerator or depressing the clutch pedal. Do not move the shift lever.
6. From low gear, shift upward to the top gear in low range, double-clutching between shifts, and accelerating to 80 percent of engine governed speed.
7. While in the top gear of the low range shift pattern, and ready for the next upshift, flip the range preselection lever up into high range. Double-clutch through neutral, and shift into the bottom

# Transmissions

gear in high range. As the shift lever passes through neutral, the transmission will automatically shift from low range to high range.

8. With the transmission in high range, shift progressively upward through each of the high range gears, double-clutching between shifts.

## Downshifting

1. With the transmission in high range, shift progressively downward to the bottom gear in high range, double-clutching between shifts.
2. When in the bottom gear of the high range shift pattern, and ready for the next downshift, push the range preselection lever down into low range. Double-clutch through neutral, and shift into the top gear of the low range shift pattern. As the shift lever passes through neutral, the transmission will automatically shift from high range to low range.
3. With the transmission in low range, downshift through the low range gears, as conditions require.

**IMPORTANT:** Never use the clutch brake when downshifting, or as a brake to slow the vehicle.

## Mercedes-Benz Manual Transmissions

### CAUTION

Operating a manual transmission with the fluid level higher or lower than recommended can result in transmission damage.

Mercedes-Benz transmissions use a simple 6-speed gear pattern as shown in [Fig. 8.18](#).

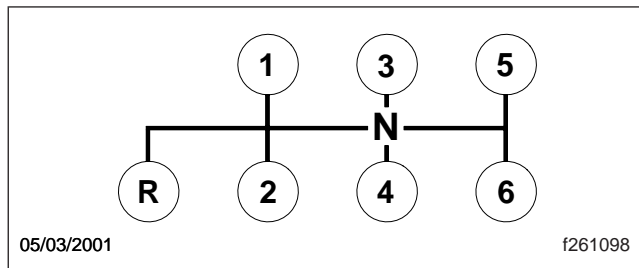


Fig. 8.18, Shift Pattern, M-B Transmissions

Always use first gear when starting to move the vehicle forward.

**IMPORTANT:** Do not rest your foot on the clutch pedal while driving. This causes partial clutch disengagement which could cause premature clutch wear.

While traveling, check the tachometer regularly to be sure the engine speed is within the most economical range (1400 to 2000 rpm).

On level roads, drive in the highest usable gear, keeping engine speed down.

### CAUTION

**Do not rest your hand on the gear shift lever while driving. This can cause synchronizer damage.**

When approaching an uphill grade, shift down ahead of time to prevent loss of engine rpm. When approaching a downhill grade, shift down ahead of time to prevent runaway speed. For information about shift points and "progressive shifting," see [Chapter 7](#).

Change gears only when absolutely necessary. Skip gears if needed.

When shifting, always press the clutch pedal all the way down. Do not force the gear lever.

Before shifting into reverse, be sure the engine is idling and the vehicle is not moving.

### CAUTION

**If the transmission locks up while driving, making further shifting impossible, continue driving in the gear already selected to reach service assistance, as circumstances allow. Or, safely park the vehicle off the roadway and contact your nearest Sterling dealer or other qualified service provider for roadside assistance. To prevent further transmission damage, do not move the vehicle from a standing start unless this can be accomplished safely, taking into account the gear that is engaged and the load on the vehicle.**

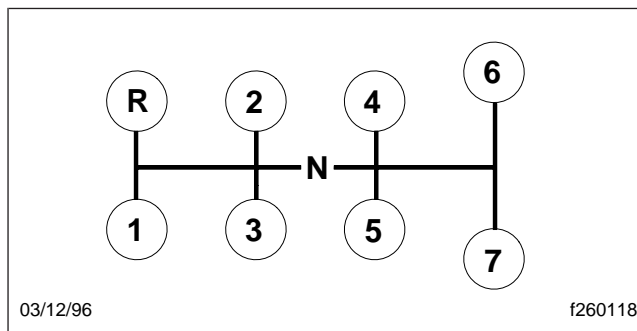


## TTC Manual Transmissions

Refer to the TTC website for additional information, [www.ttcautomotive.com](http://www.ttcautomotive.com).

### General Information, TTC

TTC (Spicer) 7-speed series transmissions are synchronized in all gears except 1st and reverse. They have seven forward gears and one reverse gear. See **Fig. 8.19** for the shift pattern.



**Fig. 8.19, TTC 7-Speed Transmission Shift Pattern**

### Operation, TTC

1. Always use 1st gear when starting to move the vehicle forward.
2. To save fuel, use progressive shifting techniques. It is usually not necessary to go all the way to governed speed before upshifting.
3. Double-clutch only when shifting out of neutral, or when shifting down into 1st.

**NOTE:** 1st gear, like reverse, is not synchronized.

### Upshifting

1. Position the gear shift lever in neutral, then start the engine. Bring the air system pressure up to 100 to 120 psi (689 to 827 kPa).
2. To shift, press down on the clutch and wait for the clutch to release completely. Move the shift lever into 1st gear and engage the clutch (remove your foot from the lever).
3. Accelerate until your rpm is high enough to shift into 2nd. Press down on the clutch and move the shift lever to second gear. Engage the clutch and continue driving.

4. Use this progressive shifting technique to shift into each higher gear. See **Fig. 8.19** for the shift pattern.

**IMPORTANT:** As you approach top speed, it will be necessary to accelerate closer and closer to governed speed before allowing the engine rpm to drop down at the next shift point.

### Downshifting

When downshifting, shift progressively down through each successive lower gear, as follows:

1. Depress the clutch pedal enough to release the torque, shift into the next lower gear, and engage the clutch smoothly while accelerating the engine to keep the vehicle moving at the desired speed.
2. Continue downshifting, as conditions require, using the same sequence described above. When shifting down into 1st gear, remember that 1st gear isn't synchronized. Double-clutch when shifting down into 1st gear.

## Allison On-Highway Transmissions

The Allison on-highway transmissions are fully automatic and include the 1000 Series™, 2000 Series™, and 2400 Series™. Refer to the Allison website for additional information, [www.allisontransmission.com](http://www.allisontransmission.com).

### Safety Precautions, On-Highway Transmissions

#### **WARNING**

**Do not leave the vehicle unattended with the engine running. If you leave the vehicle and the engine is running, the vehicle can move suddenly, which could result in personal injury or property damage.**

### 1000 Series

On vehicles with Allison 1000 series transmissions, do the following steps if you have to leave the cab with the engine running (for example, when checking the transmission fluid):

# Transmissions

---

## Without Park Position

1. Bring the vehicle to a complete stop using the service brake.
2. Ensure that the engine is at low idle rpm.
3. Put the transmission in neutral.
4. Apply the parking brake, and make sure it is properly engaged.
5. Chock the rear tires and take any other steps necessary to keep the vehicle from moving.

## With Park Position

1. Bring the vehicle to a complete stop using the service brake.
2. Ensure that the engine is at low idle rpm.
3. Put the transmission in P (park).
4. Apply the parking brake (if equipped), and make sure it is properly engaged.
5. Engage the park range by slowly releasing the service brake.
6. Chock the rear tires and take any other steps necessary to keep the vehicle from moving.

## 2000 Series

On vehicles with Allison 2000 series transmissions, do the following steps if you have to leave the cab with the engine running (for example, when checking the transmission fluid):

### Without Auto-Apply Parking Brake

Follow the instructions for vehicles with 1000 series transmissions, under the heading "Without Park Position."

### With Auto-Apply Parking Brake

1. Bring the vehicle to a complete stop using the service brake.
2. Ensure that the engine is at low idle rpm.
3. Put the transmission in PB (auto-apply parking brake).
4. Apply the parking brake (if equipped), and make sure it is properly engaged.

5. Chock the rear tires and take any other steps necessary to keep the vehicle from moving.

## 2400 Series

On vehicles with 2400 series transmissions, follow the instructions for vehicles with 1000 series transmissions.

## Range Inhibit Indicator, 2000 and 2400 Series

A RANGE INHIBIT indicator is a standard feature of the 2000 series and 2400 series transmissions. The RANGE INHIBIT indicator comes on to alert the driver that transmission operation is being inhibited and that the range shifts being requested by the driver may not occur. When certain operating conditions are detected by the TCM (transmission control module), the controls will lock the transmission in the current operating range.

Shift inhibits occur under the following conditions:

- Shifts from neutral to reverse or from neutral to a forward range when the engine is above idle, greater than 900 rpm.
- Forward/reverse directional shifts are typically not permitted if appreciable output shaft speed is detected.
- When some types of unusual transmission operating conditions are detected by the TCM, the TCM temporarily limits transmission operation until the vehicle can be driven to a service location. When this type of situation is detected, the TCM will lock the transmission in a safe gear range.
- The TCM will prevent shifts from park or neutral to range when auxiliary equipment, such as a power takeoff unit (PTO), is in operation.

## Operating Instructions, On-Highway Transmissions

Allison automatic transmissions are electronically controlled. The shift selector provides five or six forward ranges and one reverse range. A lever shift selector (**Fig. 8.20**) is used by the driver to select the ranges.

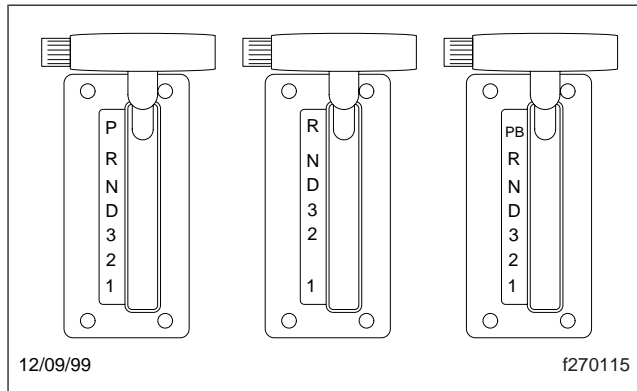


Fig. 8.20, Lever Shift Selectors

## P (Park, optional on 1000 and 2400 Series)

Use park when turning the engine on or off, to check vehicle accessories, to operate the engine in idle for longer than 5 minutes, and for stationary operation of the power takeoff, if equipped. This position places the transmission in neutral and engages the park pawl of the transmission.

NOTE: This does not apply the parking brake.

## PB (Auto-Apply Parking Brake, optional on 2000 Series)

The auto-apply parking brake places the transmission in neutral and applies the parking brake.

## R (Reverse)

Reverse is used to back the vehicle. When the selector is in reverse, the reverse warning signal will sound. Always bring the vehicle to a complete stop before shifting from a forward range to reverse, or from reverse to a forward range.

### CAUTION

Extended idling in reverse may cause transmission overheating and damage.

Do not idle in reverse for more than 5 minutes. Select P (park), PB (auto-apply parking brake), or N (neutral) when time at idle exceeds 5 minutes.

NOTE: The shift into reverse may not succeed if a range inhibitor is active. Check for illumination of the RANGE INHIBIT indicator.

## N (Neutral)

The neutral position places the transmission in neutral. This position is used when starting the engine and for stationary operation.

### WARNING

Failure to apply the vehicle parking brakes when the transmission is in neutral may allow the vehicle to move unexpectedly, possibly causing property damage or personal injury.

When neutral is selected, the vehicle service brakes, parking brake, or emergency brake must be applied. Selecting neutral does not apply vehicle brakes unless an auxiliary system to apply the parking brake is installed.

### WARNING

Do not coast in neutral. Coasting in neutral can cause an accident, possibly resulting in severe personal injury or death.

Do not let the vehicle coast in neutral. If the vehicle is allowed to coast in neutral, the engine brake will not work and you could lose control of the vehicle.

### CAUTION

Coasting in neutral can cause severe transmission damage.

## D (Drive)

### WARNING

When going downhill, use a combination of downshifting, braking, and other retarding devices to control vehicle speed and the engine's rated governed speed. Failure to do so could reduce vehicle braking, possibly causing loss of vehicle control and resulting in personal injury or property damage.

In the drive position, the transmission will initially go into first range when drive is selected. As vehicle speed increases, the transmission will upshift automatically through each available range up to fourth range or fifth range. As the vehicle slows, the transmission will downshift automatically.

# Transmissions

---

When going downhill, downshift to a lower transmission range to increase engine braking and to help maintain control. The transmission has a feature to prevent automatic upshifting above the lower range selected. However, during downhill operation, the transmission may upshift to the next higher range, if the engine is exceeding its governed speed in the lower range.

---

## CAUTION

---

**Do not idle in drive for more than 5 minutes. Extended idling in drive may cause transmission overheating and damage. Always select PB (auto-apply parking brake) or P (park) if time at idle is longer than 5 minutes.**

NOTE: The shift into drive may not succeed if a range inhibitor is active. Check for illumination of the RANGE INHIBIT indicator.

### **4 and 3 (Fourth and Third Ranges, optional)**

Use the fourth or third range for city traffic and for braking on steep downgrades.

### **3 and 2 (Third and Second Ranges, standard)**

Use the third or second range for heavy city traffic and for braking on steeper downgrades.

### **1 (First Range)**

Use first range when pulling through mud or deep snow, when maneuvering in tight spaces, or when driving up or down very steep grades. First range provides the vehicle with its maximum driving torque and maximum engine braking effect.

NOTE: To have the transmission select these ranges automatically, leave the selector lever in D (drive).

## **Allison MD Series Transmissions**

Refer to the Allison website for additional information, [www.allisontransmission.com](http://www.allisontransmission.com).

## Safety Precautions

### WARNING

**Do not leave the vehicle unattended with the engine running. If you leave the vehicle and the engine is running, the vehicle can move suddenly, which could result in personal injury or property damage.**

On vehicles with MD series transmissions, do the following steps if you have to leave the cab with the engine running (for example, when checking the transmission fluid):

1. Bring the vehicle to a complete stop using the service brake.
2. Put the transmission in N (neutral).
3. Ensure that the engine is at low idle rpm (500 to 800 rpm).
4. Apply the parking brake and emergency brakes, and make sure they are properly engaged.
5. Chock the rear tires and take any other steps necessary to keep the vehicle from moving.

## Operating Instructions, MD Series

The Allison MD transmission is electronically controlled and comes with a push-button shift control that provides five or six forward ranges and one reverse range. The push-button shift selector has an R (reverse), an N (neutral), a D (drive), an up arrow, a down arrow, a mode button, and a digital display.

New shift controls — known as "fourth generation" — were introduced in mid-2006. They replaced the previous units that are commonly referred to as "WTEC III". See [Fig. 8.21](#) and [Fig. 8.22](#).

### **R (Reverse)**

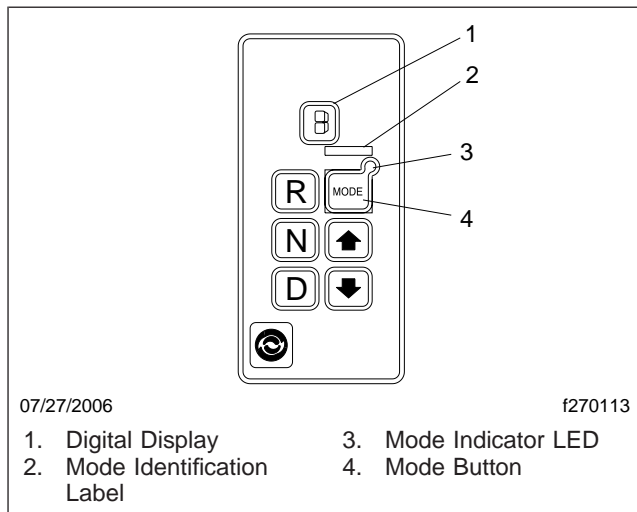
Press the R button to select reverse. The digital display will show R when reverse is selected. Always bring the vehicle to a complete stop and let the engine return to idle before shifting from a forward range to reverse, or from reverse to a forward range.

---

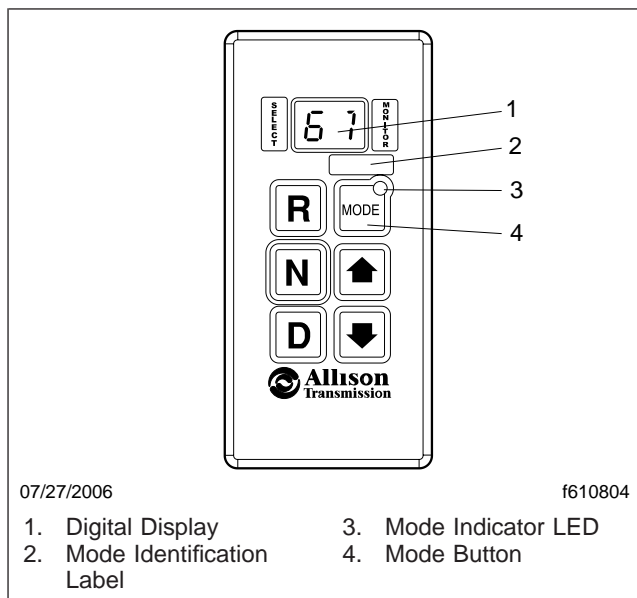
## CAUTION

---

**Extended idling in reverse may cause transmission overheating and damage.**



**Fig. 8.21, WTEC III Push-Button Shift Selector**



**Fig. 8.22, Fourth Generation Push-Button Shift Selector**

Do not idle in reverse for more than 5 minutes. Select neutral when time at idle exceeds 5 minutes.

**NOTE:** The shift into reverse may not succeed if a range inhibitor is active. When reverse is selected, always be sure that R is not flashing.

## N (Neutral)

### **! WARNING**

**When starting the engine, make sure that the service brakes are applied. Failure to apply the service brakes may result in unexpected vehicle movement, which could cause severe personal injury or death. Failure to apply the vehicle parking brakes when the transmission is in neutral may allow the vehicle to move unexpectedly, possibly causing property damage or personal injury.**

Press the N button to select neutral. The digital display will display N when neutral is selected. It is not necessary to press neutral before starting the vehicle. The ECU (electronic control unit) or TCM (transmission control module) automatically places the transmission in neutral at start-up.

### **! WARNING**

**Failure to apply the vehicle parking brakes when the transmission is in neutral may allow the vehicle to move unexpectedly, possibly causing property damage or personal injury.**

When neutral is selected, the vehicle service brakes, parking brake, or emergency brake must be applied. Selecting neutral does not apply vehicle brakes unless an auxiliary system to apply the parking brake is installed.

### **! WARNING**

**Do not coast in neutral. Coasting in neutral can cause an accident, possibly resulting in severe personal injury or death.**

Do not let the vehicle coast in neutral. If the vehicle is allowed to coast in neutral, the engine brake will not work and you could lose control of the vehicle.

Always select neutral before turning off the engine. Neutral is also used during stationary operation of the power takeoff if your vehicle is equipped with a PTO.

## D (Drive)

When the D button is pushed, the highest forward range will appear in the display. The transmission will normally go into first range when drive is selected

# Transmissions

---

(except for those units programmed to start in second range). As vehicle speed increases, the transmission will upshift automatically through each range. As the vehicle slows, the transmission will downshift automatically.

## CAUTION

**Do not idle in drive for more than 5 minutes. Extended idling in drive may cause transmission overheating and damage. Always select neutral if time at idle is longer than 5 minutes.**

NOTE: The shift into drive may not succeed if a range inhibitor is active. When drive is selected, always be sure that D is not flashing.

## **5, 4, 3, and 2 (Fifth, Fourth, Third, and Second Ranges)**

Occasionally, road conditions, load, or traffic conditions will make it desirable to restrict automatic shifting to a lower range. Lower ranges provide greater braking for going down grades. The lower the range, the greater the braking effect.

Push the up or down arrows on the push-button shift selector to select individual forward ranges. The digital display will display your choice of range. When a lower range is selected, the transmission may not downshift until the vehicle speed or engine RPM (engine governed speed) is reduced.

## WARNING

**When going downhill, use a combination of downshifting, braking, and other retarding devices to control vehicle speed and the engine's rated governed speed. Failure to do so could reduce vehicle braking, possibly causing loss of vehicle control and resulting in personal injury or property damage.**

When going downhill, downshift to a lower transmission range to increase engine braking and to help maintain control. The transmission has a feature to prevent automatic upshifting above the lower range selected. However, during downhill operation, if the engine governed speed is exceeded in the lower range, the transmission may upshift to the next higher range.

## **1 (First Range)**

Use the first range when pulling through mud or deep snow, when maneuvering in tight spaces, or when driving up or down steep grades. First range provides the vehicle with its maximum driving torque and maximum engine braking effect. Push the down arrow until the first range appears on the display.

## **Up and Down Arrows**

When a lower range is desired, after D has been pressed, press the down arrow until the desired range is shown on the display. Pressing the down arrow continuously causes the range position to continue to go down until the button is released or the lowest range is attained.

When the transmission is in drive and the down arrow has the transmission in a lower range position, press the up arrow to shift to a higher selector position. Pressing the up arrow continuously causes the range position to continue to rise until the button is released or the highest available position is attained.

Pressing the up or down arrows does not override the transmission automatic shifting operation. If a higher or lower position is selected, the transmission continues shifting through the ranges according to the vehicle operating characteristics until the highest or lowest selected position is reached.

## **Mode Button**

The MODE button starts a specialized input or output function that has been previously programmed into the ECU or TCM. Pressing the MODE button changes transmission operation for a specific function.

## **Mode Indicator LED**

When the MODE button is pressed, the mode indicator LED illuminates. A mode identification label, located above the MODE button, identifies the function associated with a mode change.

## **Digital Display**

The dual digital display shows both the selected range (SELECT) and actual range attained (MONITOR). The single digital display shows the selected range.

## Oil Level Sensor

Allison MD Series transmissions have an electronic oil level sensor to read fluid level information. The fluid level diagnostic will display whether the oil level is OK, too low, or too high. It will also display a default code and indicate if the preconditions (of receiving the fluid level information) are not met.

**IMPORTANT:** Maintain the the proper fluid level at all times. If the fluid level is too low, the converter and clutch do not receive an adequate supply of fluid. If the level is too high, the transmission may shift erratically or overheat.

To access the oil level display mode, park the vehicle on a level surface, shift to N (Neutral), apply the parking brake, and idle the engine. Then simultaneously press both the up and down arrows once. The oil level will display at the end of a two-minute countdown.

## Diagnostic Codes

Diagnostic codes are numerical indications relating to a malfunction in transmission operation. These codes are logged in the TCM/ECU memory. The most severe or most recent code is listed first. A maximum of five codes (numbered d1-d5) may be listed in memory at one time. If the mode indicator LED is illuminated, the displayed code is active. If it is not illuminated, the displayed code is not active.

**NOTE:** During normal operation, an illuminated mode indicator LED signifies the specialized mode operation is in use.

To enter diagnostics mode, first park the vehicle and apply the parking brake. Then simultaneously press both the up and down arrows twice.

## Allison AT/MT Series Transmissions

Refer to the Allison website for additional information, [www.allisontransmission.com](http://www.allisontransmission.com).

### Allison AT 500 Series

The Allison AT 500 Series transmissions provide four forward ranges and one reverse range. A lever shift selector (**Fig. 8.20**) is used by the driver to select the ranges.

## WARNING

**Do not leave the vehicle unattended with the engine running. If you leave the vehicle and the engine is running, the vehicle can move suddenly, which could result in personal injury or property damage.**

If you must leave the engine running, do not leave the vehicle until you do the following.

- Put the transmission in neutral.
- Apply the parking brake and emergency brakes and make sure they are properly engaged.
- Chock the rear tires and take any other steps necessary to keep the vehicle from moving.

## **PB (Auto-Apply Parking Brake, optional)**

When the shift selector does not have an auto-apply parking brake, always put the shift selector in neutral and apply the parking brake to hold the vehicle when it is unattended and before turning off the engine.

## **R (Reverse)**

Reverse is used to back the vehicle. Completely stop the vehicle before shifting from a forward range to reverse, or from reverse to a forward range. The reverse warning signal will sound when the selector is in reverse.

## **N (Neutral)**

Place the shift selector in neutral before starting the engine. When the shift selector has no park provision, always put the shift selector in neutral and apply the parking brake to hold the vehicle when it is unattended and before turning off the engine. The neutral position is also used during stationary operation of the power takeoff if your vehicle is equipped with a PTO.

## WARNING

**Do not let the vehicle coast in neutral. If the vehicle is allowed to coast in neutral, the engine brake will not work and you could lose control of the vehicle. This can cause an accident possibly resulting in personal injury or property damage. Coasting in neutral can also cause severe transmission damage.**

# Transmissions

---

## D (Drive)

In the drive position, the transmission will initially attain 1st range and as the vehicle speed increases, the transmission will upshift to second range, third range, and fourth range automatically. As the vehicle slows down, the transmission will downshift to the correct range automatically.

## 3 and 2 (Third and Second Ranges)

Third range and second range are used when road, load, or traffic conditions make it desirable to restrict the automatic shifting to a lower range. When conditions improve, return the selector to the drive position. The third and second ranges also provide greater engine braking for going down grades. The lower the range, the greater the braking effect.

### WARNING

**When going downhill, use a combination of downshifting, braking, and other retarding devices to control vehicle speed and the engine's rated governed speed. Failure to do so could reduce vehicle braking, possibly causing loss of vehicle control and resulting in personal injury or property damage.**

**IMPORTANT:** When descending a hill, downshift to a lower transmission range to increase engine braking and to help you maintain control. The transmission has a feature to prevent automatic upshifting above the lower range selected. However, during downhill operation, if the engine governed speed is exceeded in the lower range, the transmission may upshift to the next higher range.

## 1 (First Range)

The first range is used when pulling through mud or snow, or when driving up and down steep grades. This range provides the vehicle with maximum driving power and maximum braking power.

## Allison MT 600 Models

The Allison MT 643 transmission provides four forward ranges and one reverse range. The Allison MT 653DR transmission provides five forward ranges and one reverse range. A lever shift selector ([Fig. 8.20](#)) is used by the driver to select the ranges.

### WARNING

**Do not leave the vehicle unattended with the engine running. If you leave the vehicle and the engine is running, the vehicle can move suddenly, which could result in personal injury or property damage.**

If you must leave the engine running, do not leave the vehicle until you do the following.

- Put the transmission in neutral.
- Apply the parking brake and emergency brakes and make sure they are properly engaged.
- Chock the rear tires and take any other steps necessary to keep the vehicle from moving.

## R (Reverse)

Reverse is used to back the vehicle. Completely stop the vehicle before shifting from a forward range to reverse or from reverse to a forward range. The reverse warning signal will sound when the selector is in reverse.

## N (Neutral)

Place the shift selector in neutral before starting the engine. Shift to neutral and set the parking brake any time the vehicle is parked with the engine running. The neutral position is also used during stationary operation of the power takeoff if your vehicle is equipped with a PTO.

### WARNING

**Do not let the vehicle coast in neutral. If the vehicle is allowed to coast in neutral, the engine brake will not work and you could lose control of the vehicle. This can cause an accident possibly resulting in personal injury or property damage. Coasting in neutral can also cause severe transmission damage.**

## D (Drive)

In the drive position, the MT 643 transmission will initially attain first range and, as vehicle speed increases, the transmission will upshift to second range, third range, and fourth range. In the drive position, the MT 653DR transmission will initially attain second range and as the vehicle speed increases,



the transmission will upshift to third range, fourth range, and fifth range automatically. As the vehicle speeds slows down, the transmission will downshift to the correct range automatically.

## 4, 3, and 2 (Fourth, Third, and Second Ranges)

On the MT 643 transmission, the third range and second range are used when road, load, or traffic conditions make it desirable to restrict the automatic shifting to a lower range. When conditions improve, return the selector to the drive position. The third and second ranges also provide greater engine braking for going down grades. The lower the range, the greater the braking effect.

On the MT 653DR transmission, the fourth, third, and second ranges are used when road, load, or traffic conditions make it desirable to restrict the automatic shifting to a lower range. When conditions improve, return the selector to the drive position.

On the MT 653DR transmission, the third and second ranges are used for vehicle speed control up or down steep grades or for undesirable road conditions.

### **WARNING**

**When going downhill, use a combination of downshifting, braking, and other retarding devices to control vehicle speed and the engine's rated governed speed. Failure to do so could reduce vehicle braking, possibly causing loss of vehicle control and resulting in personal injury or property damage.**

**IMPORTANT:** When going downhill, downshift to a lower transmission range to increase engine braking and to help you maintain control. The transmission has a feature to prevent automatic upshifting above the lower range selected. However, during downhill operation, if the engine governed speed is exceeded in the lower range, the transmission may upshift to the next higher range.

## 1 (First Range)

On the MT 643 transmission, the first range is used when pulling through mud or snow, or when driving up and down steep grades. This range provides the

vehicle with maximum driving power and maximum braking power.

On the MT 653DR transmission, the first range is used for off-highway operation or when pulling through mud or snow. It is recommended that full power shifts *not* be made from first range to second range, or from second range to first range.

## Mercedes-Benz Automated Transmissions

### General Information, AGS

The AGS Automated Gear Shift is a fully automated 6-speed medium-duty transmission. The clutch is activated by a hydraulic system that is integral to the transmission. No clutch pedal is needed to operate the vehicle.

AGS transmissions use the SmartShift control lever on the steering column to select gears. A manual shift is possible at any time by moving the SmartShift lever up or down as needed.

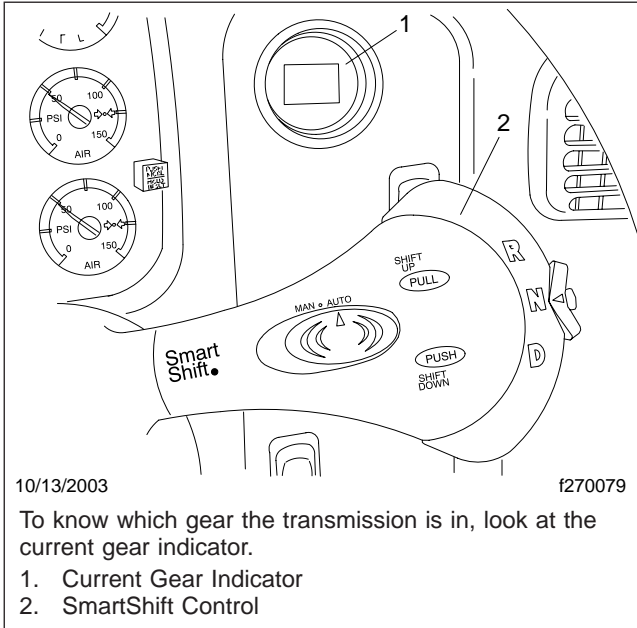
The transmission control unit (TCU) can direct all forward shifts in response to driving conditions and the driver's pressure on the brake and throttle pedals. To know which gear the transmission is in, look at the round current gear indicator on the right-hand control panel as shown in [Fig. 8.23](#).

The TCU always selects first gear to start the vehicle in motion. It is possible, in manual mode, to start an unloaded vehicle in second gear. In most cases, second gear is acceptable for downhill starts. In other situations, for best results always start moving in first gear. Loaded vehicles, or vehicles on substantial grades, must start moving only in first gear.

### **CAUTION**

**At the first sign of a transmission malfunction, take the vehicle out of service immediately. Depending on the type of problem, further shifting may not be possible, and driveline torque may be interrupted.**

# Transmissions



**Fig. 8.23, Shift Controls and Indicators, AGS Transmissions**

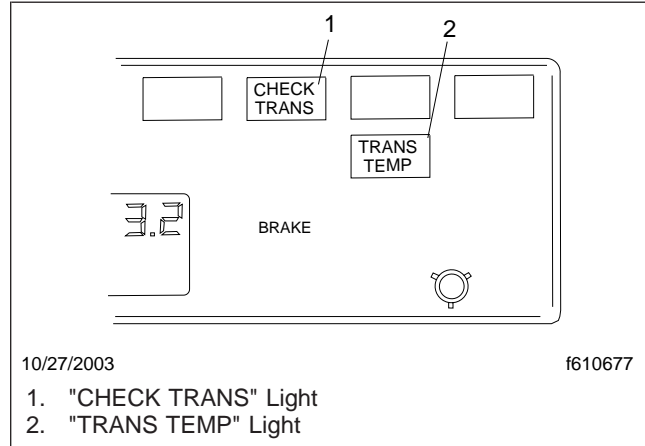
## Operation, AGS

### Power Up

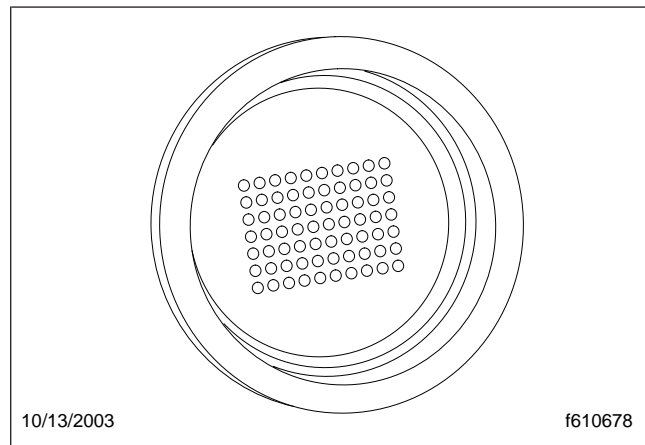
1. With the parking brake set and/or the brake pedal pressed down, select neutral (N) by moving the selector switch to the center position.
2. With the transmission in neutral, turn on the ignition switch. The "CHECK TRANS" and "TRANS TEMP" telltale lights come on and go out again (bulb check). See [Fig. 8.24](#).
3. On power up, the current gear indicator shows the dot display, arranged in a square pattern. All dots in the pattern should light up, without gaps or spaces. See [Fig. 8.25](#).
4. When the current gear indicator shows "N," start the engine.

**NOTE:** No matter what the circumstances, do not start the engine unless the current gear indicator shows "N." See [Chapter 13](#) for jump starting information.

5. Select drive (D) by pressing in the neutral lock button and moving the selector switch downward to the position below neutral. Release the park-



**Fig. 8.24, Telltale Lights**



**Fig. 8.25, Power-Up Dot Display**

ing brake and/or service brake pedal. The gear is displayed on the current gear indicator.

**NOTE:** When D is selected, the transmission starts up in first gear. To start up in second gear (downhill start, vehicle unloaded or lightly loaded), pull up on the SmartShift lever when the current gear indicator displays "1."

6. On a level grade, press down on the throttle pedal to allow the vehicle to move forward. The vehicle will not move until the pedal is depressed.

### **WARNING**

**When starting or stopping on hills and grades, use extra care to prevent the vehicle from rolling**

**back. A rollback accident could cause death, serious personal injury, or property damage.**

7. Prevent the vehicle from rolling backwards when stopped on a hill or grade, or when the vehicle is starting from a stop on a hill or grade.

- 7.1 *To start from a full stop on a hill or grade, quickly move your foot from the brake pedal and press firmly on the throttle pedal.*

On steep hills, set the parking brake and release it only when there is enough engine power to prevent rollback.

- 7.2 *To stop on a hill or grade, press and hold the brake pedal to keep the vehicle from moving.*

On steep hills, set the parking brake. Never hold a hill with the throttle pedal. This will cause the clutch to overheat.

## Power Down

1. Bring the vehicle to a complete stop.
2. Set the parking brake.
3. Move the selector switch to N. Wait until "N" appears on the current gear indicator.

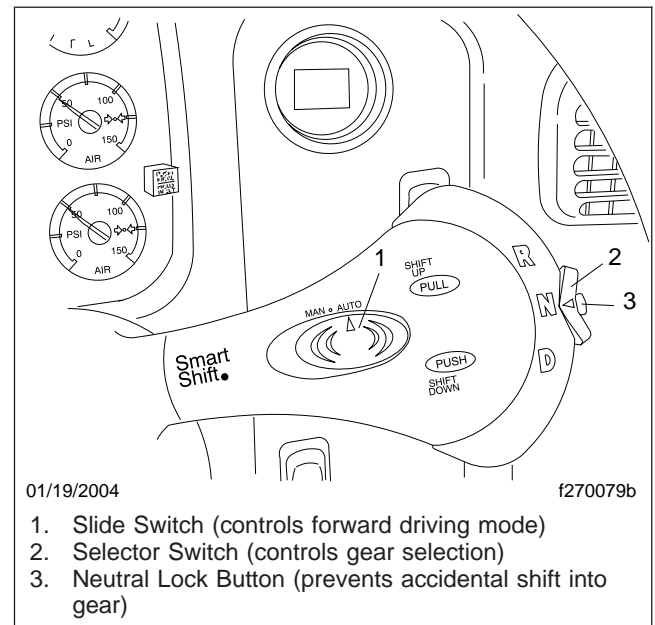
## ⚠ WARNING

**Always apply the parking brake before shutting down the engine. AGS will shift into neutral after shutdown, regardless of the position of the shift lever. If you do not set the parking brake, the vehicle could roll and cause an accident resulting in death, serious personal injury, or property damage.**

4. Turn the ignition switch off and shut down the engine.
5. If the current gear indicator flashes "PB" when the engine is shut down, set the parking brake and move the selector switch to "N."

## Automatic and Manual Modes

The SmartShift control has a slide switch located on the body of the lever just before the paddle widens out. See [Fig. 8.26](#). The slide switch controls the forward driving mode, automatic or manual.



**Fig. 8.26, Switches, AGS Transmission**

To change mode at any time, move the slide switch in the desired direction. This allows the driver to respond to a wide range of driving conditions, such as blind corners, tight curves, and steep hills.

**IMPORTANT:** Whatever the mode, it is always possible to shift manually by moving the lever up or down as needed.

In either mode, the gear indicator displays the current gear. See [Fig. 8.27](#).

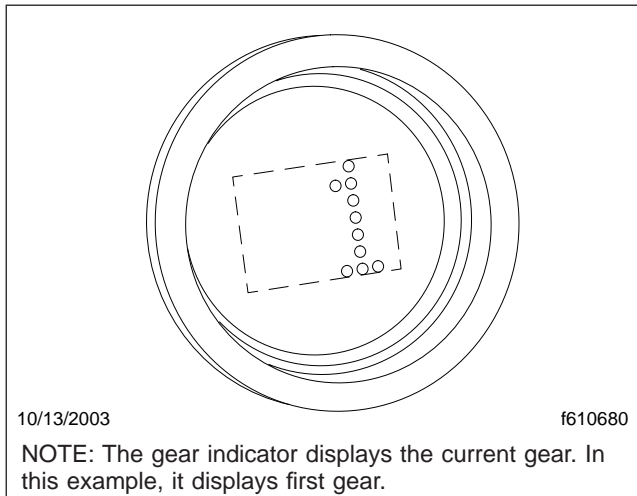
## Automatic Mode (AUTO)

Automatic drive mode (AUTO) is recommended for most driving conditions. For the best fuel economy, always use AUTO mode.

In AUTO mode, upshifts and downshifts are made by the transmission without driver intervention. Press in the neutral lock button, move the selector switch to drive (D), and press down on the throttle pedal. The transmission will shift automatically through the forward gears.

If driving conditions require, it is still possible to request a manual shift. The transmission will make the shift unless the selected gear would cause engine overspeed.

# Transmissions



**Fig. 8.27, Current Gear Display**

If the driver presses down on the throttle pedal after a manual downshift in automatic mode, the transmission will upshift again if the TCU requires it.

On downgrades, the transmission holds the current gear until the driver requests a shift, or presses the throttle pedal.

## **WARNING**

**While driving off-road or with locked differential in AUTO mode, use extra caution. Shifts of the AGS could interrupt power to the drive wheels, causing a rollback accident while climbing steep grades at low speeds. A rollback accident could cause death, serious personal injury, or property damage.**

### Manual Mode (MAN)

Manual mode may be required under certain conditions, such as:

- In difficult or slippery conditions
- On hills, steep grades, or other situations where driveline torque interruption is not desirable
- During off-road driving or driving with a locked differential
- In downhill driving where control of engine braking is needed

- If necessary to hold a specific gear on a downgrade

In manual drive mode (MAN), upshifts and downshifts are made by the driver:

- To shift up, pull the lever up (towards you).
- To shift down, push the lever down (away from you).

The system will hold the current gear until the driver requests a shift. In downhill situations in particular, the driver must be alert to vehicle speed and maintain vehicle control by downshifting and/or using the service brakes as needed.

When braking or slowing in MAN, downshift as necessary to prevent lugging the engine when speed is resumed. If the vehicle comes to a complete stop, the TCU resets the transmission to neutral.

NOTE: A downshift request will be refused if the selected gear would cause engine overspeed.

### Cruise Control

Cruise control is fully functional with AGS transmission in either AUTO or MAN mode.

In AUTO, the TCU will adjust the gear selections to maintain the speed settings as desired. No driver action is necessary.

In MAN, the vehicle speed settings must be within the engine speed range for the gear selected. If the engine cannot maintain set speed due to changes in road grade, the driver must downshift or upshift as necessary.

For vehicles equipped with a power take-off (PTO) unit, two modes of operation are possible, stationary and mobile. For PTO operation, see [Chapter 7](#).

### Selecting Gears

#### Reverse

Reverse (R) is at the upper end of the three-position selector switch located at the end of the SmartShift control lever. To select reverse (R), press in the neutral lock button and move the selector switch upward to the position above neutral. When reverse is selected, the letter "R" displays on the current gear indicator. See [Fig. 8.28](#).

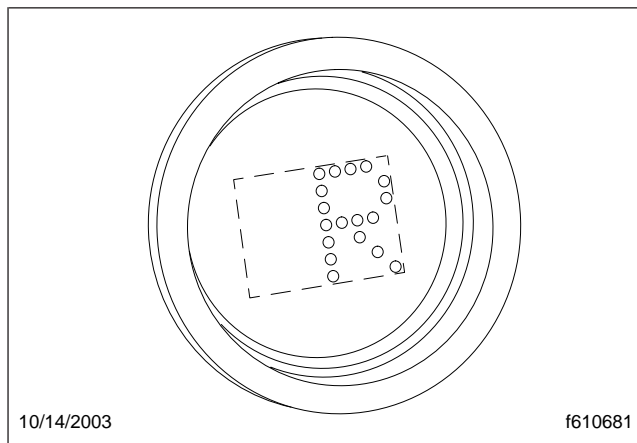
**IMPORTANT:** The vehicle must come to a complete stop before selecting reverse. If reverse is

selected with the vehicle moving forward, an audible alert will sound and continue sounding at three-second intervals until the selector switch is returned to N or D.

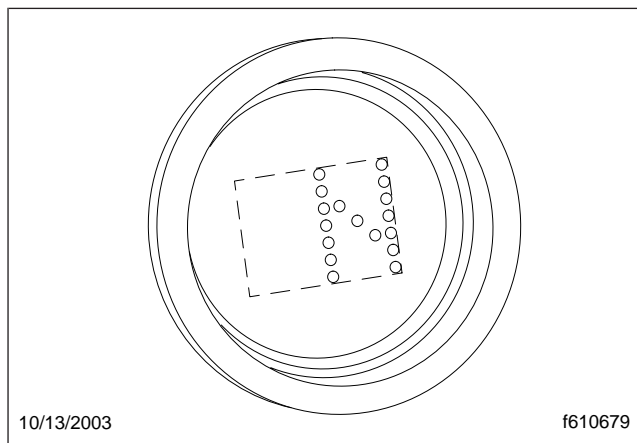
Once the vehicle has come to a complete stop, reverse can be engaged.

## Neutral

Neutral (N) is in the center of the three-position selector switch located at the end of the SmartShift control lever. Always start the engine in neutral. To select neutral, move the selector switch to the center position. When neutral is selected, the letter "N" displays on the current gear indicator. See [Fig. 8.29](#).



**Fig. 8.28, Reverse Gear Display**



**Fig. 8.29, Neutral Display**

## WARNING

**Do not coast in neutral. Coasting in neutral can cause an accident, possibly resulting in severe personal injury or death.**

Neutral is always available during operation, whatever the vehicle speed. When in neutral, requests to upshift or downshift are ignored. If the selector switch is moved from neutral to drive while the vehicle is moving, the transmission will shift into a gear within the operating torque range of the engine.

## WARNING

**Always apply the parking brake before shutting down the engine. AGS will shift into neutral after shutdown, regardless of the position of the shift lever. If you do not set the parking brake, the vehicle could roll and cause an accident resulting in death, serious personal injury, or property damage.**

Before shutting down the engine, return the selector switch to "N." When the ignition is turned off, the transmission will reset to neutral during power down.

## Drive

**IMPORTANT:** The vehicle must come to a complete stop before selecting drive. If drive is selected with the vehicle moving in reverse, an audible alert will sound and continue sounding at three-second intervals until the selector switch is returned to N or R.

Drive (D) is at the lower end of the three-position selector switch located at the end of the SmartShift control lever. To select drive, press in the neutral lock button and move the selector switch to the position below N. When drive is selected, the number of the currently selected forward gear (1, 2, 3, 4, 5, or 6) displays on the gear indicator. See [Fig. 8.27](#).

## Upshifting

**NOTE:** The driver can manually upshift at any time, even when the slide switch is set to AUTO mode.

To request an upshift with the transmission in drive, pull the control lever up (towards you). If the gear is

# Transmissions

---

available, the transmission upshifts and the new gear displays on the gear indicator.

As in a manual transmission, upshifting too early causes engine lugging and uneven operation.

To achieve smooth operation in MAN mode, upshift when the engine speed reaches approximately 2000 revolutions per minute (rpm). Heavy loads or steep grades require higher rpm; lighter loads require lower rpm.

An unavailable request to upshift is not stored in memory. The upshift must be requested again.

## Downshifting

**NOTE:** The driver can manually downshift at any time, even when the slide switch is set to AUTO mode.

To request a downshift with the transmission in drive, push the control lever down (away from you). If the gear is available, the transmission downshifts and the new gear displays on the gear indicator.

Downshifts are not available if the engine speed after the shift would exceed 2700 rpm. If the gear requested is unavailable, an audible alert will sound. An unavailable request to downshift is not stored in memory. The downshift must be requested again.

**IMPORTANT:** A downshift request can never result in a shift into neutral, even if the vehicle is in the drive position in the lowest possible gear.

To achieve smooth operation in MAN mode, downshift when the engine speed reaches approximately 1200 rpm.

Before starting down a hill, slow down. Downshift to a speed that you can control without hard pressure on the service brakes.

Before entering a curve, slow down to a safe speed. Downshift if necessary. This lets you use some power through the curve to help the vehicle be more stable on the turn. It also allows you to regain speed faster as you come out of the curve.

## AGS Diagnostics



**CAUTION**

**At the first sign of a transmission malfunction, take the vehicle out of service immediately. De-**

**pending on the type of problem, further shifting may not be possible, and driveline torque may be interrupted.**

## System Malfunction

If the "CHECK TRANS" telltale light comes on while driving, the audible alert sounds, and the current gear indicator begins to flash between the current gear and "SM" (system malfunction), there is a problem which may or may not be apparent to the driver. Bring the vehicle at once to a safe stopping place and call an authorized Freightliner service facility for assistance.

## Clutch Overload

If the "TRANS TEMP" telltale light comes on while driving and the current gear indicator begins to flash between the current gear and "CO" (clutch overload), the clutch has begun to overheat.

The clutch overload may have been caused by improper driving practices such as frequent and rapid start/stop driving, or hillholding with the throttle pedal. In this case, allow the clutch to cool, and continue on, but cease the improper driving practices.

If the clutch overload message returns or continues, the clutch is worn or damaged. Bring the vehicle at once to a safe stopping place and call an authorized Freightliner service facility for assistance.

## Low Hydraulic Fluid Level

**IMPORTANT:** The only hydraulic fluid permitted in this system is Pentosin CHF 11S. No other fluid can be substituted.

If the "CHECK TRANS" telltale light comes on while driving and the current gear indicator begins to flash between the current gear and "FL" (fluid level), there has been an unusual loss of hydraulic fluid. Bring the vehicle at once to a safe stopping place and call an authorized Freightliner service facility for assistance. The hydraulic reservoir holds about 1.05 quarts (one liter) of Pentosin CHF 11S.

**NOTE:** After hydraulic fluid loss, a special procedure is required to fill the hydraulic reservoir. This procedure must be carried out by an authorized Freightliner service facility.

# 9

## Rear Axles

---

Meritor™ Drive Axles With Wheel Lock .....	9.1
Meritor™ Wheel Lock Operation .....	9.1
Meritor™ Tandem Drive Axles With Axle Lock .....	9.2
Meritor™ Axle Lock Operation .....	9.2

# Rear Axles

## Meritor™ Drive Axles With Wheel Lock

The Meritor wheel lock is a driver-controlled traction device operated from the vehicle cab. The wheel lock switch (Fig. 9.1) allows the driver to lock the wheels on the same axle together. The wheel lock indicator light comes on when the wheel lock is turned on.

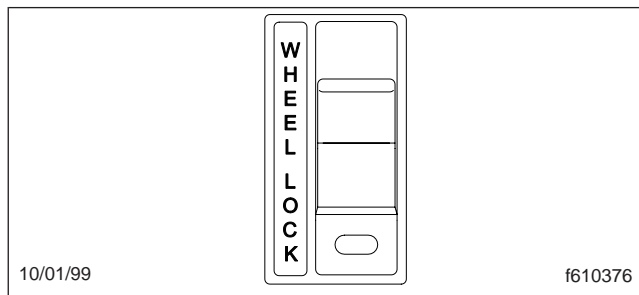


Fig. 9.1, Wheel Lock Switch

The wheel lock provides maximum traction under slippery conditions. When the wheel lock is engaged, the clutch collar completely locks the differential case, gearing, and axle shafts together, maximizing the traction of both wheels and protecting against spinout.

Under normal traction conditions, do not use the wheel lock feature.

### **WARNING**

**Be especially careful when driving under slippery conditions with the differential locked. Though forward traction is improved, the vehicle can still slip sideways, causing possible loss of vehicle control, personal injury, and property damage.**

## Meritor™ Wheel Lock Operation

To lock the wheels and obtain maximum traction under slippery conditions, push the wheel lock switch up.

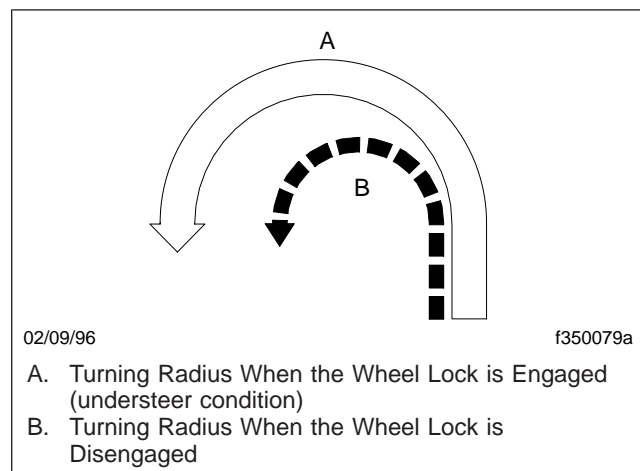
### **WARNING**

**Lock the wheels only when the vehicle is standing still or moving less than 25 mph (40 km/h). Never lock the wheels when the vehicle is travel-**

**ing down steep grades or when the wheels are slipping. This could damage the differential or lead to loss of vehicle control, causing personal injury and property damage.**

**NOTE:** On some vehicles, the wheel lock system is connected through the low speed range of the transmission. If this system is used, the transmission must be in the low speed range for the wheels to fully lock.

If the vehicle is moving, maintain a constant vehicle speed when the wheel lock is turned on. Briefly let up on the accelerator to relieve torque on the gearing, allowing the wheels to fully lock. The wheel lock indicator comes on when the wheel lock is turned on. When the wheels are fully locked, the turning radius will increase because the vehicle understeers. See Fig. 9.2. Drive cautiously and do not exceed 25 mph (40 km/h).



- 02/09/96 f350079a
- A. Turning Radius When the Wheel Lock is Engaged (understeer condition)
  - B. Turning Radius When the Wheel Lock is Disengaged

Fig. 9.2, Turning Radii

To disengage the wheel lock, move the wheel lock switch to the center position. Briefly let up on the accelerator to relieve torque on the gearing, allowing the wheels to fully unlock.

**NOTE:** If the wheel lock system is connected through the low speed range of the transmission, shifting out of low speed range will also disengage the wheel lock.

When the wheel lock is disengaged, the wheel lock indicator will turn off.



### Meritor™ Tandem Drive Axles With Axle Lock

Meritor tandem drive axles have an axle lock feature. The axle lock is controlled by the axle lock switch (Fig. 9.3) on the control panel.

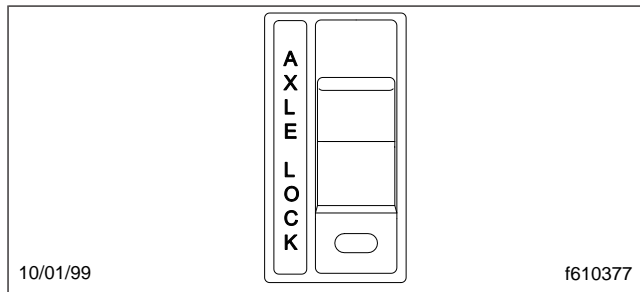


Fig. 9.3, Axle Lock Switch

When the axle lock is not engaged, there is differential action between the two axles. The differential compensates for different wheel speeds and variations in tire size. Keep the axle lock disengaged when driving on roads where traction is good.

When the axle lock is engaged, the axles are locked together and the driveshaft becomes a solid connection between the two axles. Power entering the forward axle is transmitted straight through to the rear axle so that both axles turn together at the same speed. The axle lock should be used when the vehicle encounters poor traction conditions; however, it also increases drivetrain and tire wear and should be used only when improved traction is required.

### Meritor™ Axle Lock Operation

To engage the axle lock and achieve maximum pulling power when approaching slippery or poor road conditions, push the axle lock switch up while maintaining vehicle speed. Let up momentarily on the accelerator to engage the axle lock. Proceed over poor road conditions with caution. Do not wait until traction is lost and the tires are spinning before engaging the axle lock.

#### CAUTION

**Do not turn the differential lock switch on while the WHEEL SPIN indicator light is on. To do so could damage the rear axle.**

To disengage the axle lock after leaving poor road conditions, move the axle lock switch to the center position while maintaining vehicle speed. Let up momentarily on the accelerator to allow the shift, then resume driving at normal speed.

# 10

## Fifth Wheels

---

Holland Fifth Wheels .....	10.1
Fontaine® Fifth Wheels .....	10.3

# Fifth Wheels

---

## Holland Fifth Wheels

### 3500 Series Stationary Models

Holland 3500 Series stationary fifth wheels are best suited for applications where the axle loading, kingpin setting, and vehicle combination length all remain constant throughout the fleet. The stationary fifth wheel can be a plate mount or an angle mount. See [Fig. 10.1](#).

The Type B kingpin lock mechanism ([Fig. 10.2](#)) utilizes two spring-loaded lock halves. The final forward motion of the kingpin into the open lock halves forces the locks to close around the kingpin. The kingpin can be released only by pulling the release handle all the way out. The lock adjustment nut will compensate for wear on the lock or kingpin.

### Fifth Wheel Locking Operation

#### Locking the Fifth Wheel Mechanism

1. Make sure the coupling area is level and clear of persons and obstacles.
2. The fifth wheel plate must be completely lubricated with chassis grease. For lubrication instructions, see **Group 31** of the *Acterra® Maintenance Manual*.

 **WARNING**

**Keep the fifth wheel plate lubricated to prevent binding between the tractor and trailer. A binding fifth wheel could cause erratic steering and loss of vehicle control, possibly resulting in serious personal injury or death.**

3. Make sure the locks are open. If the locks are closed, pull the release handle all the way out.
4. Position the tractor so that the fifth wheel lock opening is in line with the trailer kingpin.
5. Back the tractor close to the trailer and stop.
6. Chock the trailer wheels.
7. Apply the trailer brakes.
8. Adjust the trailer height so that the fifth wheel will lift the trailer. The trailer should contact the fifth wheel four to six inches (10 cm to 15 cm) behind the fifth wheel bracket pin.
9. Slowly back the tractor in to the trailer.

10. Test for kingpin lockup by pulling on the trailer against the chocks. Check for correct maximum clearance between the lock halves. If more than 1/8-inch (3.2-mm) clearance exists between the lock halves, the lock must be adjusted. See **Group 31** of the *Acterra® Workshop Manual* for adjustment procedures.

 **WARNING**

**Adjust the locks correctly to a maximum clearance of 1/8 inch (3 mm). Incorrect adjustment of the lock could cause the trailer to disconnect, possibly resulting in serious personal injury or death.**

11. Make a visual inspection for proper kingpin lockup. Make sure the lock is closed and that the adjustment nut is snug against the fifth wheel.

 **WARNING**

**The coupling procedure is not complete without an inspection. You must get out of the tractor and verify that the fifth wheel is properly coupled to the kingpin. Failure to verify that the fifth wheel is properly coupled to the kingpin could cause the trailer to detach from the tractor, possibly resulting in serious personal injury or death.**

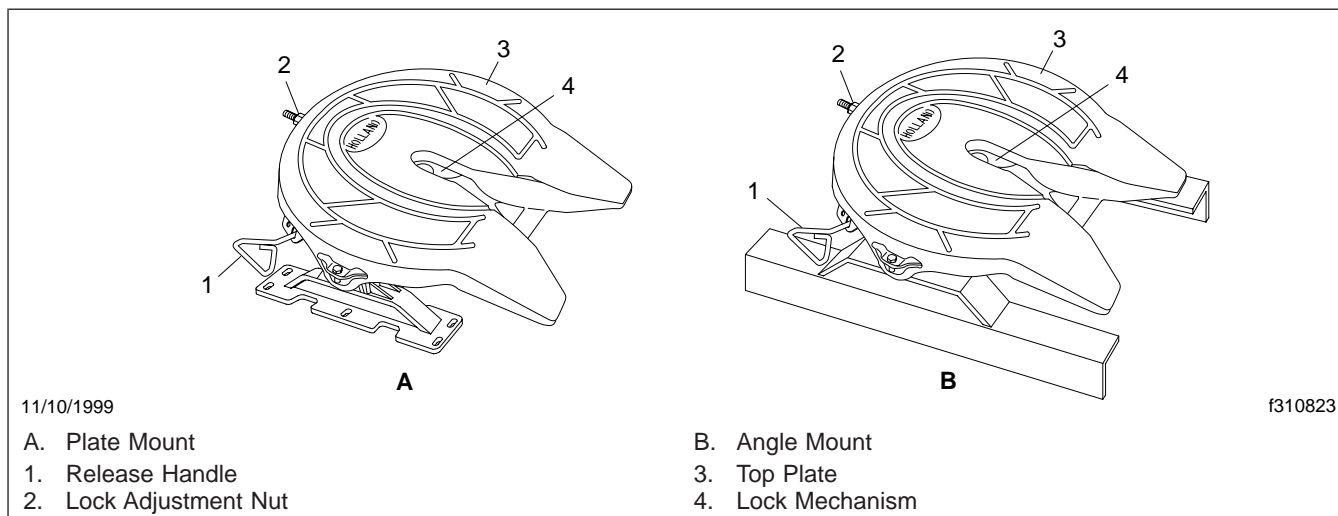
---

### NOTICE

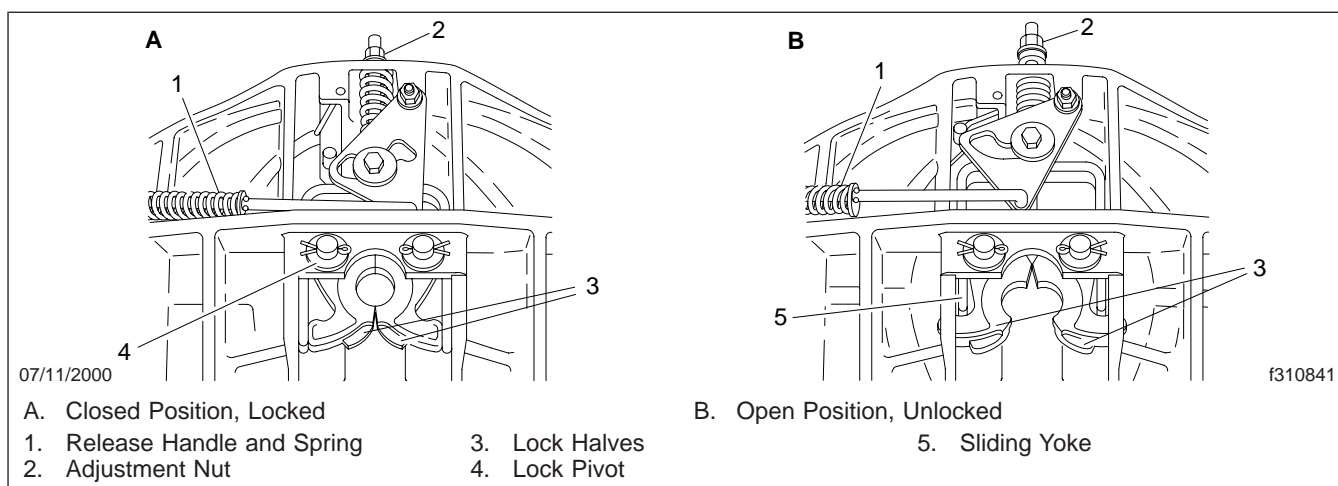
---

**Always make sure the connect-hanger/support keeps the trailer air hoses and electrical cables positioned so that they do not rub on anything. Rubbing may wear through hoses or cables, resulting in air leaks, or exposed or broken wires, potentially affecting trailer brake or electrical systems.**

12. After lockup is completed, connect the tractor-to-trailer air system lines and electrical cable to the trailer. Take care to prevent dirt or foreign material from entering the air lines.
13. Charge the air brake system with air. Make sure that the air connections do not leak.
14. Retract the trailer landing gear and secure the ratchet handle.
15. Remove the chocks from the trailer tires.



**Fig. 10.1, Holland 3500 Series Fifth Wheels**



**Fig. 10.2, Type B Kingpin Lock Mechanism (bottom view)**

16. The load distribution on the front steering axle and rear drive axle(s) will have a direct effect on the steering control of the vehicle.

Determine the front and rear axle weights by weighing the vehicle on scales designed for this purpose.

The maximum axle weight ratings are shown on the Federal Motor Vehicle Safety Standard (FMVSS) label or Canadian Motor Vehicle Safety Standard (CMVSS) label attached to the left rear door post of the tractor. The desired load on the axle is no less than 80 percent of the maximum axle weight rating, but in no instances should the

axle load exceed the maximum axle weight rating given on the FMVSS or CMVSS label.

## **WARNING**

**Do not overload any tractor axle by improperly loading the trailer. This could cause erratic steering and loss of vehicle control, possibly resulting in serious personal injury or death.**

### **Unlocking the Fifth Wheel Lock Mechanism**

1. Apply the tractor parking brakes.

# Fifth Wheels

2. Pull the trailer air supply valve to cut off the air supply to the trailer.
3. Chock the front and rear of the trailer tires to prevent the trailer from moving.

## WARNING

**Do not use the trailer service brakes for parking; they are not designed for this purpose. If air bleeds out of the trailer air tank during parking, the vehicle could roll causing serious personal injury or property damage.**

4. Lower the trailer landing gear until the weight is removed from the fifth wheel.
5. Disconnect the tractor-to-trailer air system lines and electrical cable. Plug the air lines to prevent dirt or foreign material from entering the lines.
6. Release the kingpin locking mechanism by pulling the release handle (Fig. 10.1) all the way out.
7. Slowly drive the tractor away from the trailer.

## Fontaine® Fifth Wheels

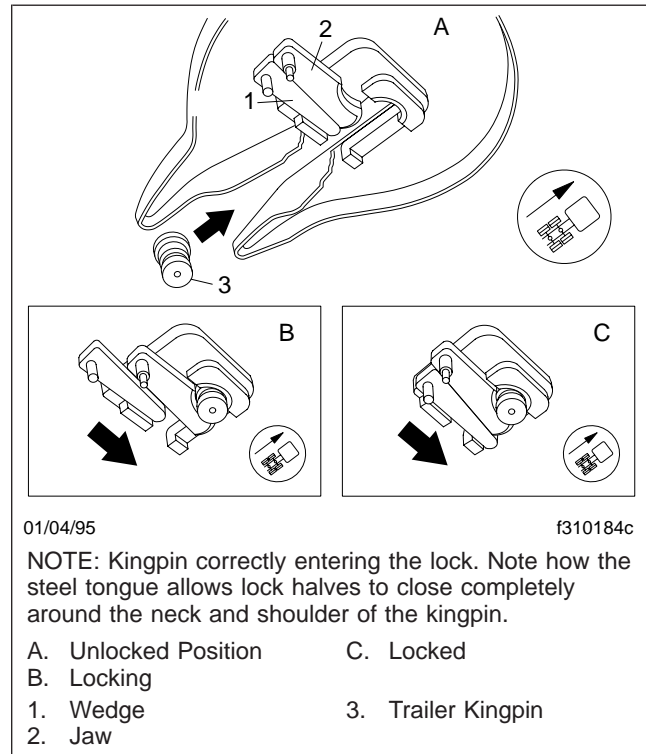
### 6000/7000 Series No-Slack® II Stationary Models

On Fontaine fifth wheels, kingpin release is accomplished by pulling the release handle located on the side of the fifth wheel. Kingpin lockup occurs when the kingpin is forced into the jaws and the release handle moves to the locked position.

The fifth wheel top plate is mounted to the tractor frame using a mounting angle. The fifth wheel should be mounted in a position that best distributes the trailer load over the tractor axles.

### Fifth Wheel Lock Mechanism for Trailer Kingpin

The Fontaine fifth wheel lock mechanism (Fig. 10.3) for the trailer kingpin consists of a spring-loaded jaw and a sliding wedge. The jaw and wedge each have a pin permanently attached. The pin on the jaw and the pin on the wedge fit into elongated notches in the release handle. The notches in the handle control the limit of movement for both the jaw and wedge. The notches are arranged so that the wedge is actuated first during release of the kingpin.



**Fig. 10.3, Fontaine Kingpin Lock Mechanism**

During lockup, the jaw is moved first with the spring-loaded wedge being allowed to slip into place against the jaw. A timing bracket ensures that the wedge and jaw are moved at the correct time.

Placing the release handle in the unlocked position moves the wedge away from the jaw. This action unlocks the jaw so that it can be moved by the trailer kingpin. When the tractor is moved out from under the trailer, the kingpin moves the jaw until the kingpin is out of the mechanism. With the jaw in the unlocked position, the release handle will remain in the unlocked position until manually moved by the operator.

During coupling, the motion of the kingpin entering the jaw will move the jaw and wedge. The jaw will move behind the kingpin, followed by the wedge. The purpose of the wedge is to reinforce the jaw and take up slack around the pin. Any wear on the jaw is immediately taken up by the wedge so there is no slack in the connection.

Correct adjustment of the wedge stop rod is important to the proper functioning of the locking mechanism. For adjustment instructions, see **Group 31** of the *Acterra® Maintenance Manual*.

Special precautions must be taken during cold weather to ensure that the Fontaine® No-Slack® locking mechanism operates freely. Ice and sludge can build up and lubricants become thick and binding at low temperatures. When the temperature drops below freezing, Fontaine recommends the use of a cleaner or degreaser on the latching mechanism, making sure that the moving parts operate freely. This should be followed by an application of 90-weight oil to all moving parts.

## Fifth Wheel Locking Operation

### Locking the Fifth Wheel Lock Mechanism

1. Chock the front and rear of the trailer tires to prevent the trailer from moving.
2. The kingpin lock mechanism must be fully open, the release handle should be in the extended position, and the fifth wheel plate must be completely lubricated with chassis grease. If the fifth wheel is equipped with a retractable handle, the handle will not be fully extended. For lubrication instructions, see **Group 31** of the *Acterra® Maintenance Manual*.

### **WARNING**

**Keep the fifth wheel plate lubricated to prevent binding between the tractor and trailer. A binding fifth wheel could cause erratic steering and loss of vehicle control, possibly resulting in serious personal injury or death.**

3. Position the tractor so that the fifth wheel lock opening is in line (both vertically and horizontally) with the trailer kingpin. The kingpin should be in a position to enter the throat of the locking mechanism, as shown in **Fig. 10.3**. Adjust the trailer landing gear to give enough alignment height for positive kingpin lockup.
4. With the fifth wheel lock opening aligned with the trailer kingpin, back the tractor slowly toward the trailer, making sure that the kingpin enters the throat of the locking mechanism. Continue backward motion until positive lockup occurs.
5. Apply the tractor parking brakes.

6. Make a visual and physical check for positive kingpin lockup. When lockup has occurred, the fifth wheel release handle will have moved to the locked position. See **Fig. 10.4**.
7. Release the tractor parking brakes. Test for kingpin lockup by pulling on the trailer against the chocks.

### **NOTICE**

**Always make sure the connect-hanger/support keeps the trailer air hoses and electrical cables positioned so that they do not rub on anything. Rubbing may wear through hoses or cables, resulting in air leaks, or exposed or broken wires, potentially affecting trailer brake or electrical systems.**

8. After lockup is completed, connect the tractor-to-trailer air system lines and the electrical cable to the trailer. Take care to prevent dirt or foreign material from entering the air system lines.
9. Charge the air brake system with air. Make sure that the air connections do not leak.
10. With the trailer wheels chocked and the brakes set, check for clearance between the kingpin and the fifth wheel jaws by moving the tractor forward and backward against the locked kingpin. There should be no slack between the tractor and the trailer. If slack is present, uncouple the trailer.

For adjustment instructions, refer to the manufacturer's service information.

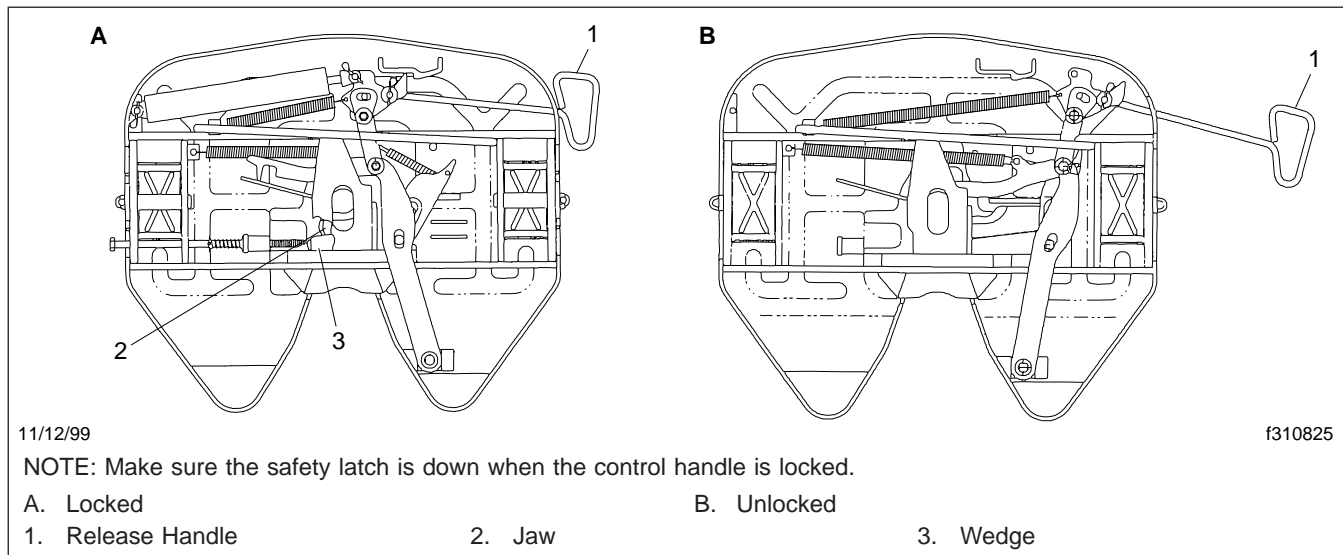
### **WARNING**

**Eliminate slack between the trailer and the tractor. Incorrect fifth wheel adjustment could cause the trailer to disconnect, possibly resulting in serious personal injury or death.**

11. Retract the trailer landing gear, and secure the ratchet handle.
12. Remove the chocks from the trailer tires.
13. The load distribution on the front steering axle and rear drive axle(s) will have a direct effect on the steering control of the vehicle.

Determine the front and rear axle weights by weighing the vehicle on scales designed for this purpose.

# Fifth Wheels



**Fig. 10.4, Fontaine 6000/7000 Series Fifth Wheel, Locked and Unlocked (bottom view)**

The maximum axle weight ratings are given on the Federal Motor Vehicle Safety Standard (FMVSS) label or Canadian Motor Vehicle Safety Standard (CMVSS) label attached to the left rear door post of the tractor. The desired load on the axle is no less than 80 percent of the maximum axle weight rating, but in no case should the axle load exceed the maximum axle weight rating given on the FMVSS or CMVSS label.

## **WARNING**

**Do not overload any tractor axle by improperly loading the trailer. This could cause erratic steering and loss of vehicle control, possibly resulting in serious personal injury or death.**

### **Unlocking the Fifth Wheel Lock Mechanism**

1. Apply the tractor parking brakes.
2. Pull the trailer air supply valve to cut off the air supply to the trailer.
3. Chock the front and rear of the trailer tires to prevent the trailer from moving.

## **WARNING**

**Do not use the trailer service brakes for parking; they are not designed for this purpose. If air**

**bleeds out of the trailer air tank during parking, the vehicle could roll causing serious personal injury or property damage.**

4. Lower the trailer landing gear until the weight is removed from the fifth wheel.
5. Disconnect the tractor-to-trailer air system lines and electrical cable. Plug the air lines to prevent dirt or foreign material from entering the lines.
6. Release the kingpin locking mechanism by pulling the release handle to the unlocked position. See [Fig. 10.4](#).
7. Slowly drive the tractor away from the trailer.

# 11

## Pretrip and Post-Trip Inspections and Maintenance

---

Pretrip and Post-Trip Inspection Checklists .....	11.1
Pretrip and Post-Trip Maintenance Procedures .....	11.3



# Pretrip and Post-Trip Inspections and Maintenance

---

## Pretrip and Post-Trip Inspection Checklists

Regulations in both Canada and the United States clearly indicate that it is the driver's responsibility to perform an inspection and ensure the complete road-worthiness of a vehicle before placing it into service for the day. Commercial vehicles may be subject to inspection by authorized inspectors, and an unsafe vehicle can be put "out of service" until the driver or owner repairs it.

**IMPORTANT:** The pre- and post-trip checklists, and inspections and maintenance procedures detailed in this chapter, are **not all-inclusive**. Also refer to other component and body manufacturers' instructions for specific inspection and maintenance instructions.

Use the inspection checklists to ensure that vehicle components are in good working condition before each trip. A driver that is familiar with the vehicle, and drives it regularly, can perform the daily inspections, then add the weekly and monthly post-trip inspections as scheduled. If the driver does not operate the vehicle on a consistent basis, all three of the inspection procedures should be performed before the trip.

**NOTE:** Procedure reference numbers in the the checklists reference the corresponding detailed instructions found under the pretrip and post-trip maintenance procedures.

Pre- and post-trip inspections cannot be done quickly. However, careful inspections save time by eliminating stops later to adjust items overlooked or forgotten.

If any system or component does not pass this inspection, it must be corrected before operating the vehicle. Whenever equipment requires adjustment, replacement, repair, addition of lubricants, or a change of lubricants, see the *Acterra® Workshop Manual* for procedures and specifications, and see the *Acterra® Maintenance Manual* for lubricant recommendations, specifications, and maintenance intervals.

See [Table 11.1](#) for a list of procedures that should be performed daily, before the first trip.

See [Table 11.2](#) for a list of procedures that should be performed weekly, post-trip.

See [Table 11.3](#) for a list of procedures that should be performed monthly, post-trip.

**IMPORTANT:** Before performing any checks, apply the parking brake and chock the tires.

# Pretrip and Post-Trip Inspections and Maintenance

Procedure Performed (check off)	Daily Pretrip Inspections/Checks	Procedure Reference
_____	Drain manually drained air reservoirs (that are not equipped with automatic drain valves)	D1
Check _____	windshield washer reservoir fluid	D2
Inspect _____	wheel seal and hub cap (for leakage)	—
Check _____	surge tank coolant level	D3
Inspect _____	radiator and charge air cooler	D4
Check _____	engine for fuel, oil, or coolant leaks	—
Inspect _____	engine and chassis wiring	D5
Inspect _____	air intake system	D6
Check _____	intake-air restriction indicator mounted on air intake	D6
Check _____	engine oil level	D7
Check _____	power steering fluid level	—
Inspect _____	fuel tank(s), fuel lines, and connections	D8
Check _____	fuel level	D9
Check _____	fuel/water separator	D10
Inspect _____	front and rear suspension components	D11
Inspect _____	headlights, mirrors, and window glass, and windshield wipers	D12
Check _____	doors (open without difficulty and close securely)	—
_____	Adjust driver's seat, then align rearview and downview mirrors	—
Check _____	dash-mounted intake-air restriction indicator	D6
Check _____	oil- and air-pressure warning systems	D13
Check _____	ICU fault codes	D14
Check _____	horn, windshield wipers, and windshield washer	D15
Check _____	heater, defroster, and optional mirror heat controls	D16
Check _____	backup alarm	—
Check _____	panel lights and interior lights	D17
Check _____	exterior lights and reflectors	D18
Check _____	tire pressure	D19
Inspect _____	tire condition	D20
Inspect _____	rims and wheels	D21
Check _____	automatic transmission fluid level	—
Inspect _____	air brake chambers and pushrods	D22
Inspect _____	air brake lines	D23
Inspect _____	slack adjusters	D24
Check _____	air brake system operation	D25
Inspect _____	frame rails (missing bolts), crossmembers (bent or loose)	—
Check _____	mud flaps (aren't damaged, at least 10 inches above the ground, and brackets are secure)	—
Check _____	exhaust system (mounted securely, connected tightly, no signs of leaks such as soot trails)	—
_____	Remove chocks and test service brakes	D26
Inspector _____ Date _____		

**Table 11.1, Daily Pretrip Inspection and Maintenance Checklist**

# Pretrip and Post-Trip Inspections and Maintenance

Procedure Performed (check off)	Weekly Post-Trip Inspections/Checks	Procedure Reference
_____	Manually drain air reservoirs that are equipped with automatic drain valves	—
Inspect _____	batteries and battery cables	W1
Check _____	wheel bearing lubricant level	W2
Inspect _____	steering components	W3
Check _____	serpentine drive belt condition	W4
Check _____	V-belt tension	W5
Inspect _____	seat belts and tether belts	W6
Inspector _____ Date _____		

Table 11.2, Weekly Post-Trip Inspection and Maintenance Checklist

Procedure Performed (check off)	Monthly Post-Trip Inspections/Checks	Procedure Reference
_____	Clean the battery terminals	M1
Inspect _____	radiator hoses and heater hoses	M2
Check _____	fluid level in the hydraulic clutch reservoir (if applicable, and if necessary, fill with DOT 4 brake fluid)	—
Check _____	steering wheel play	M3
Check _____	outer surfaces of the hood and body (for visible surface breaks and damage)	—
Check _____	hood tilt damper (attached at both ends)	—
Inspect _____	brake lining wear	M4
Inspect _____	driveshaft	—
Inspector _____ Date _____		

Table 11.3, Monthly Post-Trip Inspection and Maintenance Checklist

## Pretrip and Post-Trip Maintenance Procedures

### Daily Pretrip Inspection and Maintenance

Whenever equipment requires adjustment, replacement, and/or repair, see the *Acterra® Workshop Manual* for procedures and specifications. Specific references to the manual will be found where appropriate.

#### 1. Drain manually drained air reservoirs.

Water and oil normally enter the air reservoir in the form of vapor because of the heat generated during compression. After the water and oil condense, drain the resulting emulsion as follows:

- 1.1 Open the wet tank valve. The drain cock or pull chain drain is located on the forward end of the supply air reservoir, which is connected directly to the air compressor. Block the valve open.



**WARNING**

**When draining the air reservoir, do not look into the air jets or direct them toward anyone. Dirt or sludge particles may be in the airstream and could cause injury.**

- 1.2 Exhaust the remaining air and moisture from the system by opening the drain cocks on the bottoms of the remaining air reservoirs. Block the valves open.

# Pretrip and Post-Trip Inspections and Maintenance

1.3 Water and oil emulsion often form pockets that will not drain while compressed air is in the reservoirs. Because of these pockets, leave the valves blocked open during the first part of the pretrip inspection.

1.4 If the drained water is cloudy or oily, it may indicate a problem with the compressor. If oil is allowed to contaminate the air dryer, it will not remove the water from the air brake system, which could adversely affect braking.

2. Check the fluid level in the windshield washer reservoir.

Add washer fluid as needed. Unscrew the cap to add fluid.

## WARNING

Washer fluids may be flammable and poisonous. Do not expose washer fluid to an open flame or any burning material, such as a cigarette. Always comply with the washer fluid manufacturer's recommended safety precautions.

3. Check the coolant level in the surge tank.

See Fig. 11.1. If the coolant is low, add a 50/50 mixture of water and the type of antifreeze currently installed in your vehicle. Fill the surge tank with coolant to the MAX line when the tank is cool. If the surge tank was empty, start the engine after refilling and check the level again when the engine is at operating temperature.

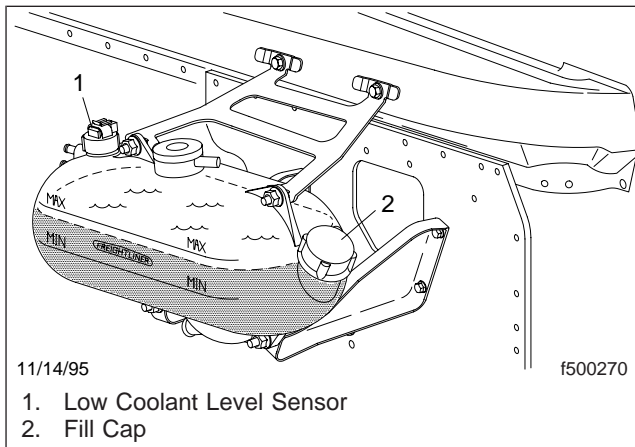


Fig. 11.1, Coolant Level Checking

## CAUTION

Coolant must be filled to the full line of the surge tank. Low coolant could result in engine overheating, which could cause engine damage.

4. Inspect the radiator and charge air cooler.

4.1 Inspect the radiator and charge air cooler for clogged fins. Use compressed air or water directed from the fan side of the core to backflush any material restricting airflow.

4.2 Inspect the radiator and charge air cooler for damage and accumulated debris. Straighten bent or damaged fins to permit airflow across all areas of the cores.

NOTE: When traveling through areas of high insect concentration, it may be necessary to clean the exterior of the radiator or the charge air cooler core as often as every 200 miles (320 km).

4.3 On vehicles equipped with air conditioning, also inspect and clean the condenser. If clogged, the condenser can restrict airflow through the radiator.

4.4 Check the radiator for leaks. If leaks are found, have the radiator repaired or replaced. See Group 20 of the Acterra® Workshop Manual for instructions, or take the vehicle to an authorized Sterling dealer.

5. Inspect the engine and chassis wiring.

Check for loose wiring, chafed insulation, and damaged or loose hold-down clamps. Tighten loose wires or hold-down clamps; replace damaged wiring or clamps.

6. Inspect the air intake system for leaks or damage.

## CAUTION

Failure to maintain a sealed air intake system could allow the entry of dirt and contaminants into the engine. This could adversely affect engine performance and result in engine damage.

6.1 Check the intake-air restriction indicator.

# Pretrip and Post-Trip Inspections and Maintenance

- 6.2 Replace the filter element if the yellow signal stays locked at 25 inH<sub>2</sub>O for Cummins or Caterpillar engines or 22 inH<sub>2</sub>O for Mercedes-Benz engines. See **Group 09** of the *Acterra® Workshop Manual* for filter element replacement instructions.

**NOTE:** After replacing the filter element, reset the restriction indicator by pressing the rubber reset button.

- 6.3 Inspect the secondary or safety filter element in the air cleaner when replacing the primary element, and replace it when clogged or dirty. This element should be replaced with every third primary element replacement.

- 6.4 Check the engine air intake piping from the air cleaner to the engine intake. Inspect the piping for loose connections, cracks, torn or collapsed hoses, punctures, and other damage. Tighten loose connections, and have damaged components replaced. Make sure the piping system is airtight so that all intake air passes through the air cleaner.

## 7. Check the engine oil level.

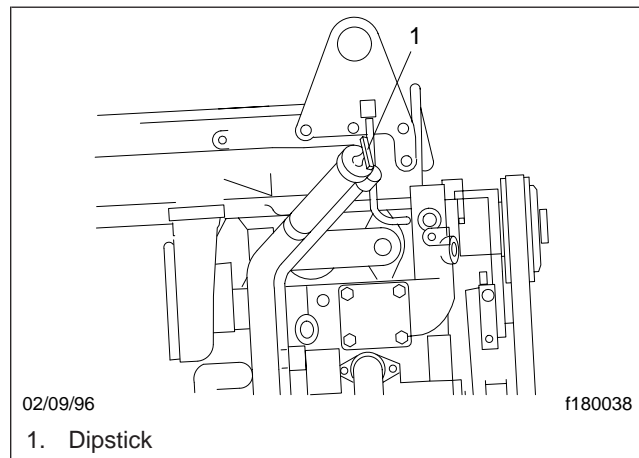
If the oil level is at or below the minimum fill (or "add") mark on the dipstick, add enough oil to maintain the level between the minimum fill (or "add") and the maximum fill (or "full") marks on the dipstick. See **Fig. 11.2**. Engine lube oil must have a sulfated ash level less than 1.0 wt %; currently referred to as CJ-4 oil. Use the proper SAE viscosity rating for the temperature and time of year.

## CAUTION

Operating the engine with the oil level below the minimum fill (or "add") mark or above the maximum fill (or "full") mark could result in engine damage.

## 8. Inspect the fuel tanks, fuel lines, and connections for leaks.

- 8.1 Check that the fuel tanks are secured to their mounting brackets and that the mounting brackets are secured to the frame.



**Fig. 11.2, Oil Level Checking**

- 8.2 Replace leaking fuel tanks.
- 8.3 If lines or connections are leaking, have them repaired or replaced.
- For repair and/or replacement procedures, see **Group 47** of the *Acterra® Workshop Manual*, or take the vehicle in to an authorized Sterling dealer.
- 8.4 If equipped with fuel tank shutoff valves, be sure the valves are fully open.

## WARNING

Never operate the engine with the fuel tank shut-off valves partly closed. This could damage the fuel pump, causing sudden loss of engine power, possibly resulting in serious personal injury due to reduced vehicle control.

## 9. Check the fuel level in the fuel tank(s).

To keep condensation to a minimum, fuel tanks should be filled at the end of each day. Federal regulations prohibit filling a fuel tank to more than 95 percent of its liquid capacity.

## WARNING

Never fill fuel tanks to more than 95 percent of their liquid capacity. This could make them more likely to rupture from impact, possibly causing fire and resulting in serious personal injury or death by burning.

# Pretrip and Post-Trip Inspections and Maintenance

**Do not mix gasoline or alcohol with diesel fuel. This mixture could cause an explosion, possibly resulting in serious personal injury or death. Do not fill the fuel tanks in the presence of sparks, open flames, or intense heat. These could ignite the fuel, possibly causing severe burns.**

**IMPORTANT:** Use ultralow-sulfur diesel (ULSD) with 15 ppm sulfur content or less, based on ASTM D2622 test procedure. Failure to use ultralow-sulfur diesel fuels may void the warranty on emission components.

- 9.1 Fuel should always be strained or filtered before being put into the tanks. This will lengthen the life of the engine fuel filter and reduce the chances of dirt getting into the engine.
  - 9.2 Before installing the fuel cap, clean the area with a rag, or if necessary, clean the cap with solvent.
  - 9.3 If needed, prime the fuel system. For priming procedures, see the applicable engine manufacturer's manual.
10. *If equipped with a fuel/water separator, check it for contaminants.*
- 10.1 With the engine shut down, partially open the drain valve under the collection bowl and drain water and contaminants as needed.
  - 10.2 Check the fuel/water separator for leaks.

**IMPORTANT:** When draining fluid from a fuel/water separator, drain the fluid into an appropriate container and dispose of it properly. Many states now issue fines for draining fuel/water separators onto the ground. On all types of separators, stop draining fluid when you see fuel come out of the separator drain valve.

11. *Inspect the front and rear suspension components, including springs, spring hangers, shocks, and suspension brackets.*
- 11.1 Check for broken spring leaves, loose U-bolts, cracks in the suspension brackets, and loose fasteners in the spring hangers and shackles.
  - 11.2 Inspect the shock absorbers for loose fasteners and leaks.

11.3 Tighten all loose fasteners and have any component(s) replaced that are worn, cracked, or otherwise damaged.

11.4 On vehicles with air suspensions, check for leaks. Check air suspension components for cuts and bulges.

12. *Clean the windshield, side, and rear windows, then check the condition of the windshield wiper arms and blades.*

12.1 Replace the wiper arms if the wiper blades are not tensioned against the windshield.

12.2 Replace damaged or deteriorated wiper blades.

## **WARNING**

**When cleaning windshields and windows, always stand on the ground or on a secure ladder or platform. Use a long-handled window cleaner. Do not use the cab steps, tires, fenders, fuel tanks, engine, or under-hood components to access the windshield or windows. Doing so could cause a fall and result in an injury.**

13. *Check the oil- and air-pressure warning systems.*

13.1 Check if the warning systems come on when the ignition is turned on, and if not, have the systems repaired.

13.2 Start the engine, then check that the oil- and air-pressure warning systems are operating. The buzzer should stop sounding when the preset minimum is reached. If the air pressure in both systems is above the preset minimum when the engine is started, test the low air pressure warning system by lowering the pressure to below this range, or until the warning system comes on.

The air pressure in both the primary and secondary air reservoir systems must be above 65 psi (448 kPa) on most vehicles. For vehicles with an optional Bendix dryer reservoir module (DRM), the cut-out pressure is 130 psi (896 kPa).

14. *Check the instrumentation control unit (ICU) for fault codes.*

# Pretrip and Post-Trip Inspections and Maintenance

During the ignition sequence, if an active fault is detected in any device that is connected to the ECU, the message display screen will show the active fault codes, one after the other, until the parking brake is released or the ignition switch is turned off. See [Chapter 2](#) for detailed operating instructions for the ICU.

15. *Make sure that the horn, windshield wipers, and windshield washers are operating properly. These devices must be in good working order for safe vehicle operation.*

15.1 Make sure that the horn works. If a horn is not working, have it repaired before trip departure.

15.2 Check the wiper and washer control on the multifunction turn signal switch. If the wipers and/or washers are not working, have them repaired before trip departure.

16. *During cold weather, make sure the heater, defroster, and optional mirror heat controls are operating properly. If so equipped, turn on the mirror heat switch and make sure the system is working.*

17. *Check the operation of all the panel lights and interior lights.*

Turn on the headlights, dash lights, and four-way flashers and leave them on. If any of the gauge bulbs, the dome light bulbs, or the right- and left-turn indicator bulbs are not working, replace them.

18. *Make sure all the exterior lights are working properly.*

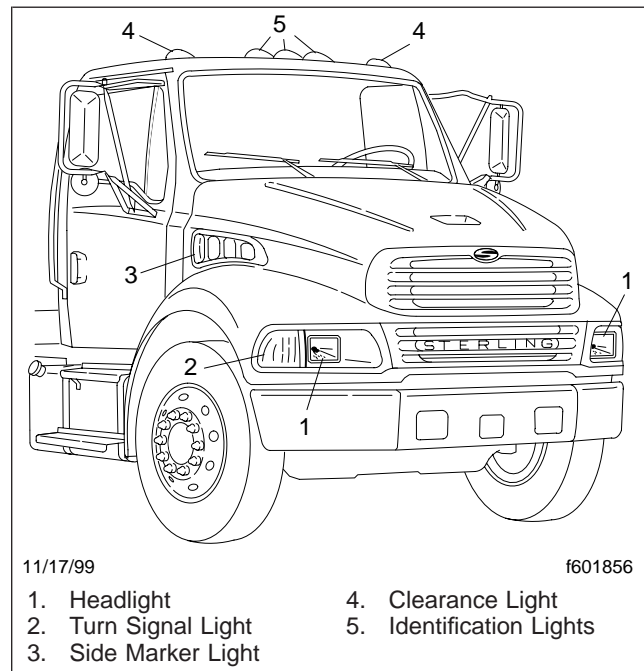
Check that all the lights and reflectors are clean. See [Fig. 11.3](#).

18.1 Check that the brake lights, taillights, headlights, parking lights, turn signals, marker lights, identification lights, road lights (if so equipped), and front clearance lights are working properly and are clean.

18.2 Test the high and low beams of the headlights.

18.3 Replace light bulbs or sealed beam units that are not working.

18.4 Be sure all reflectors and lenses are in good condition and are clean. Replace any broken reflectors or lenses.



**Fig. 11.3, Exterior Light Locations**

19. *Check tire inflation pressures using an accurate tire pressure gauge.*

Tires should be checked when cool. For inflation pressures and maximum loads (per tire) see the tire manufacturer's guidelines.

19.1 Be sure valve stem caps are on every tire and that they are screwed on finger-tight.

19.2 Inflate the tires to the applicable pressures if needed. A weekly pressure loss of 4 psi (28 kPa) or more in a tire may indicate damage. The tire should be inspected and, if necessary, repaired or replaced.

19.3 If a tire has been run flat or underinflated, check the wheel for proper lockring and side-ring seating, and possible wheel, rim, or tire damage before adding air.

Moisture inside a tire can result in body ply separation or a sidewall rupture. During tire inflation, compressed air reservoirs and lines must be kept dry. Use well-maintained inline moisture traps and service them regularly.

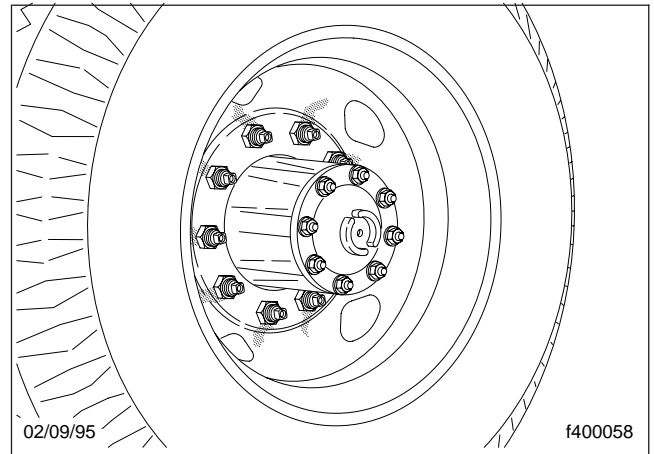
# Pretrip and Post-Trip Inspections and Maintenance

## WARNING

Do not operate the vehicle with underinflated or overinflated tires. Incorrect inflation can stress the tires and make the tires and rims more susceptible to damage, possibly leading to rim or tire failure and loss of vehicle control, resulting in serious personal injury or death.

IMPORTANT: The load and cold inflation pressure must not exceed the rim or wheel manufacturer's recommendations, even though the tire may be approved for a higher load inflation. Some rims and wheels are stamped with a maximum load and maximum cold inflation rating. If they are not stamped, consult the rim or wheel manufacturer for the correct tire inflation pressure for the vehicle load. If the load exceeds the maximum rim or wheel capacity, the load must be adjusted or reduced.

20. *Inspect each tire for wear, bulges, cracks, cuts, penetrations, and oil contamination.*
  - 20.1 Check the tire tread depth. If tread is less than 4/32 inch (3 mm) on any front tire, or less than 2/32 inch (1.5 mm) on any rear tire, replace the tire.
  - 20.2 Inspect each tire for bulges, cracks, cuts, and penetrations.
  - 20.3 Inspect each tire for oil contamination. Fuel oil, gasoline, and other petroleum derivatives, if allowed to contact the tires, will soften the rubber and destroy the tire.
21. *Check the wheel nuts or rim nuts for indications of looseness. Examine each rim and wheel component.*
  - 21.1 Remove all dirt and foreign material from the assembly. Dirt or rust streaks from the stud holes, metal buildup around stud holes, or out-of-round or worn stud holes may be caused by loose wheel nuts. See [Fig. 11.4](#) and [Fig. 11.5](#).
  - 21.2 Examine the rim and wheel assembly components (including rims, rings, flanges, studs, and nuts) for cracks, or other damage.



**Fig. 11.4, Dirt and Rust Streaks from the Stud Holes**

See **Group 33** or **Group 35** of the *Acterra® Workshop Manual* for service procedures on the studs and hubs, and see **Group 40** in the same manual for wheel and tire servicing, or take the vehicle to an authorized Sterling dealer.

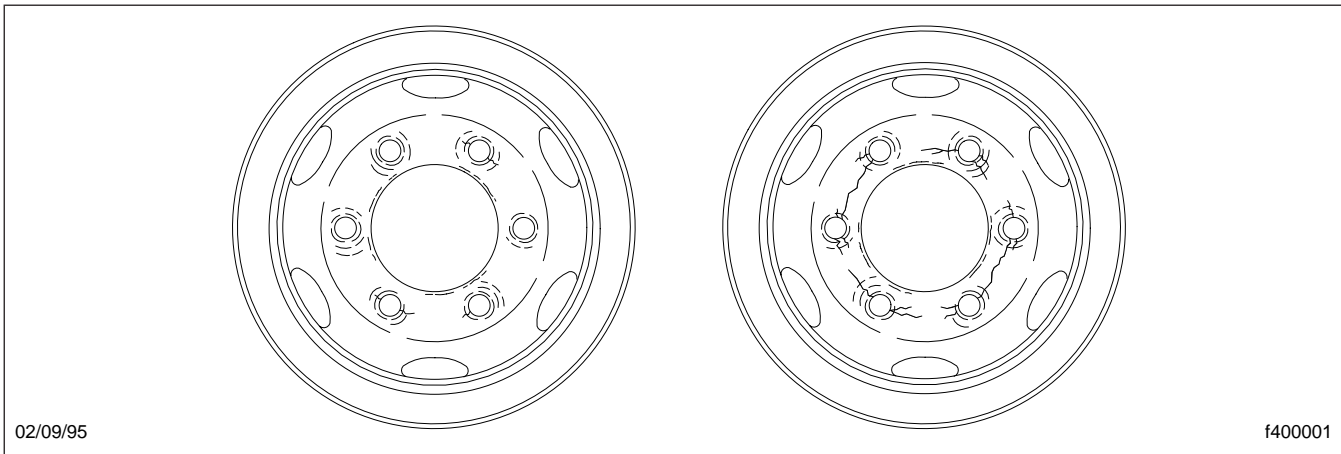
## WARNING

**Have any worn or damaged wheel components replaced by a qualified person using the wheel manufacturer's instructions and the wheel industry's standard safety precautions and equipment. Otherwise a vehicle or workshop accident could occur, possibly resulting in serious personal injury or death.**

- 21.3 Have broken, cracked, badly worn, bent, rusty, or sprung rings and rims replaced. Be sure that the rim base, lockring, and side ring are matched according to size and type.
- 21.4 Make sure all wheel nuts are tightened 450 to 500 lbf-ft (610 to 678 N·m) for Accuride wheels with unlubricated threads. Use the tightening pattern in [Fig. 11.6](#) for 10-hole wheels and the tightening pattern in [Fig. 11.7](#) for 8-hole wheels. See **Group 40** of the *Acterra® Workshop Manual* for more information.



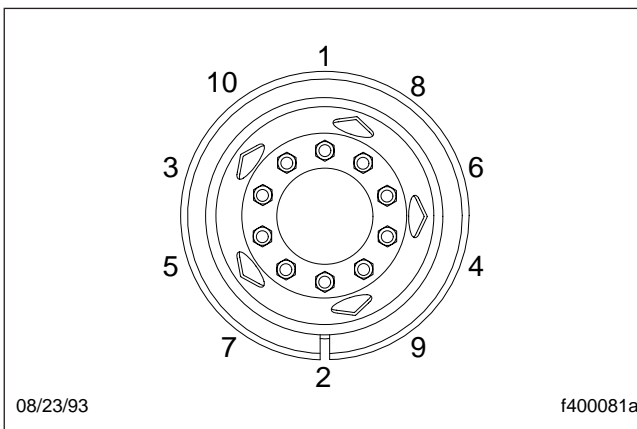
# Pretrip and Post-Trip Inspections and Maintenance



02/09/95

f400001

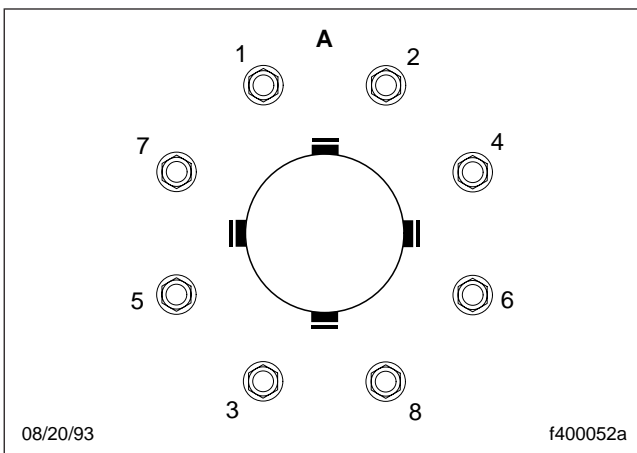
Fig. 11.5, Worn Stud Holes



08/23/93

f400081a

Fig. 11.6, Tightening Pattern, 10-Hole Wheels



08/20/93

f400052a

Fig. 11.7, Tightening Pattern, 8-Hole Wheels

## CAUTION

Insufficient wheel nut torque can cause wheel shimmy, resulting in wheel damage, stud breakage, and extreme tire tread wear. Excessive wheel nut torque can break studs, damage threads, and crack discs in the stud hole area. Use the recommended torque values and follow the proper tightening sequence.

NOTE: Vehicles operating under severe or adverse conditions should be checked more frequently.

22. *Inspect the air brake chamber and the air brake chamber pushrods.*

## WARNING

Do not operate the vehicle with the front brakes backed off or disconnected. Backing off or disconnecting the front brakes will not improve vehicle handling and may lead to loss of vehicle control resulting in property damage or personal injury.

22.1 Check that the air brake chamber is mounted securely on its mounting bracket, and that there are no loose or missing bolts.

# Pretrip and Post-Trip Inspections and Maintenance

- 22.2 Look for worn clevis pins on brake chamber pushrods and missing or damaged cotter pins on brake chamber pushrod clevis pins. Replace worn clevis pins and install new cotter pins if necessary.
- 22.3 See if the chamber piston rod is in line with the slack adjuster. Misalignment can cause the piston rod to rub on the non-pressure chamber and cause a dragging brake. See **Group 42** of the *Acterra® Workshop Manual*.

## CAUTION

If the external breather tube or breather cap is missing or incorrectly installed, road dirt and debris can adversely affect the operation of the brake chamber. Once inside of the chamber, dirt and debris can cause the internal parts of the chamber to deteriorate faster.

- 22.4 Inspect the exterior surfaces of the chamber for damage. Make sure that breather holes in the non-pressure section(s) are open and free of debris. See **Group 42** of the *Acterra® Workshop Manual* to replace any damaged parts.

## DANGER

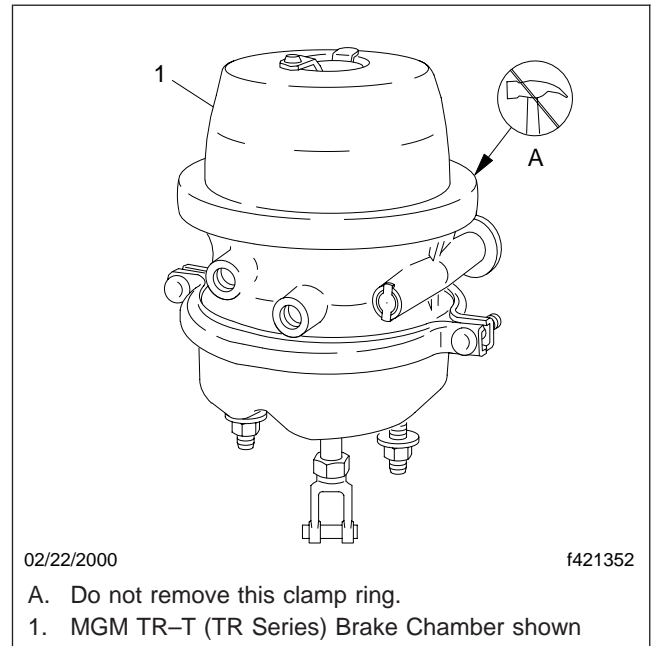
Do not loosen or remove the parking brake clamp ring for any purpose. The parking/emergency brake section of the brake chamber is not intended to be serviced. Serious injury or death may result from sudden release of the power spring.

- 22.5 On all parking brake installations, make sure the end cover cap or dust plug is securely snapped into place. See **Fig. 11.8**.

NOTE: On most MGM parking brake chambers equipped with an integral release bolt, an end cover cap is installed over the release bolt.

- 22.6 Check for rusted connections, missing snap rings, and damaged camshaft grease seals. Have damaged or missing parts repaired or replaced.

23. Inspect the air brake lines.



**Fig. 11.8, Parking Brake Chamber Clamp**

- 23.1 Check the clearance between the hoses and the exhaust manifold or other hot spots. Excessive heat will cause material in the hoses to deteriorate rapidly or become brittle. Provide at least 6 inches (150 mm) of clearance. More clearance is recommended if the hose is located above the heat source.
- 23.2 Check for kinks, dents, or swelling of the hoses. If damaged, have the hose replaced with the same size and type.

NOTE: Do not route the hose on top of anything likely to be stepped on.

- 23.3 Check for damage to hoses located near moving parts, such as drivelines, kingpins, suspensions, and axles. If moving parts are catching or pinching the lines, correct as needed.
- 23.4 Check for hose damage caused by abrasion. If abraded, have the hose replaced. Check for the cause of abrasion, such as loose or damaged hose clamps. Have the clamps repaired or replaced as needed.

# Pretrip and Post-Trip Inspections and Maintenance

- 23.5 Observe the hose cover condition, especially hoses exposed to water splash and ice. If dried out or ragged (the wire or liner is showing through the cover), have the hose(s) replaced.
- 23.6 Inspect the air tubing, especially tubing made of nylon. In cold weather, nylon tubing is sensitive to damage, such as nicks or cuts. Have nicked or cut tubing replaced, even if it is not leaking.
- 23.7 Check for kinked or twisted hoses. A seven-percent twist in the hose can reduce its life by up to 90 percent. A twisted hose under pressure tends to untwist, which may loosen the fitting. Reconnect hoses that are twisted.

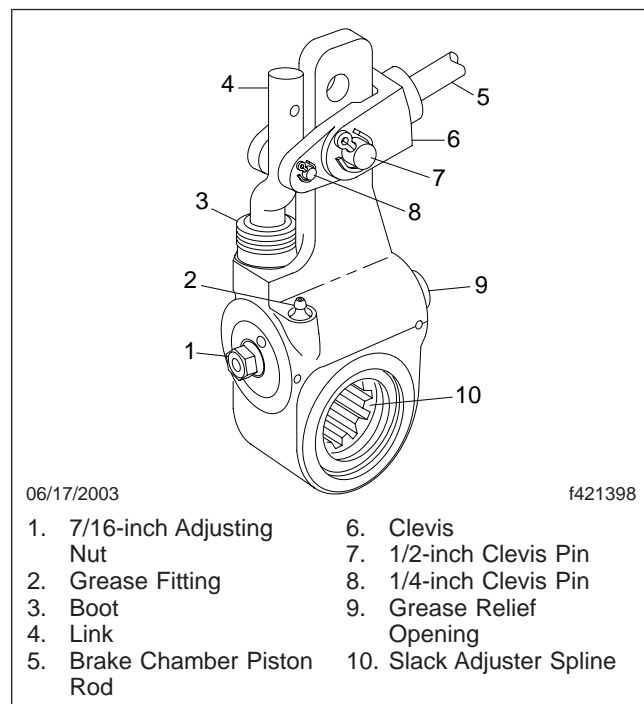
**NOTE:** The front brake lines flex continuously in vehicle operation, so they require special examination. Give particular attention to the areas near where they connect to the front air brake chambers. This inspection requires two people, one in the driver seat and another to inspect the brake line connections at the wheels.

- 23.8 Both wheel air lines must be inspected with the emergency brake set, engine idling, air pressure at 80 to 90 psi (550 to 620 kPa), and the brake pedal held down.
- 23.9 Turn the wheels to full lock in one direction and inspect both air lines where they connect to the air chambers, then turn the wheels to full lock in the other direction and inspect both lines. If a hose is leaking, have it replaced.

**IMPORTANT:** ABS-equipped vehicles operating in regions where especially corrosive ice removal chemicals are used may experience higher than normal rotor corrosion. Tone rings should be routinely inspected for corrosion. Severe corrosion of the integral ABS tone ring may cause the ABS warning lamp in the dash to illuminate due to false wheel speed readings. If the ABS warning lamp illuminates at any time other than at vehicle start-up, have the problem repaired immediately.

## 24. Inspect the slack adjusters.

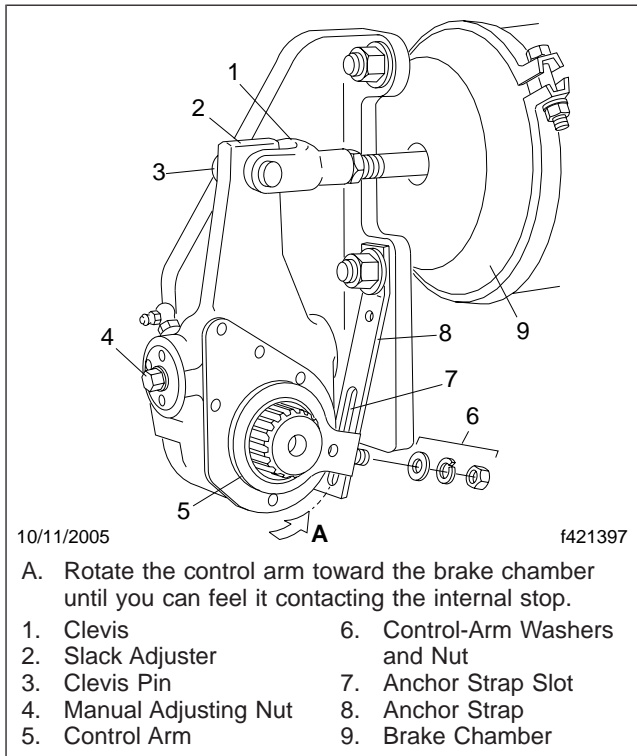
- 24.1 *Meritor Slack Adjusters:* Check the boot for cuts, tears, or other damage. Have it replaced if necessary.
- 24.2 *Gunite Slack Adjusters:* Inspect the slack adjuster for any signs of damage. If damaged, have the slack adjuster replaced.  
Inspect the slack adjuster boot for cuts or tears. If the boot is damaged, have it replaced. See **Fig. 11.9**.



**Fig. 11.9, Gunite Automatic Slack Adjuster**

- 24.3 *Haldex Slack Adjusters:* Inspect each slack adjuster and anchor strap for damage. See **Fig. 11.10**. Have any damaged components replaced.
- 25. *Check the air brake system for proper operation.*
  - 25.1 Check the air governor cut-in and cut-out pressures as follows.  
Run the engine at fast idle. The air governor should cut out the air compressor at approximately 120 psi (827 kPa). With the engine idling, apply the brake pedal several times. The air governor should cut in the air compressor at approximately 100 psi (689 kPa). If the air governor does not

# Pretrip and Post-Trip Inspections and Maintenance



**Fig. 11.10, Haldex Automatic Slack Adjuster**

cut in and out as described above, it must be adjusted to these specifications. If the air governor cannot be adjusted or repaired, replace it before operating the vehicle.

- 25.2 Check the air pressure buildup time as follows.

With the air system fully charged to 120 psi (827 kPa), make one full brake application and note the air pressure reading on the gauge. Continue to reduce the air pressure by moderate brake applications to a maximum of 90 psi (620 kPa), then run the engine at governed rpm. If the time required to raise the air pressure to 120 psi (827 kPa) (from the pressure noted after one brake application) is more than 30 seconds, eliminate any leaks or replace the air compressor before operating the vehicle.

- 25.3 Check the air pressure reserve as follows.

With the air system fully charged to 120 psi (827 kPa), stop the engine and note the air pressure. Then make one full brake application and observe the pressure drop. If it drops more than 25 psi (172 kPa), all areas of leakage must be eliminated before operating the vehicle.

- 25.4 Check the air leakage in the system as follows.

With the parking brake (spring brake) applied, the transmission out of gear, and the tires chocked, charge the air system until cut-out pressure of 120 psi (827 kPa) is reached.

With the service brakes released, shut down the engine, wait 1 minute and note the air pressure gauge reading. Observe the air pressure drop in psi (kPa) per minute.

Charge the air system until cut-out pressure of 120 psi (827 kPa) is reached. With the parking brakes released and the service brake applied, shut down the engine, wait 1 minute and note the air pressure gauge reading. Observe the air pressure drop in psi (kPa) per minute.

If leakage exceeds the limits shown in [Table 11.4](#), repair all areas of leakage before driving the vehicle.

Maximum Allowable Service Brake Air Leakage		
Description	Air Leakage in psi (kPa) Per Minute	
	Released	Applied
Truck or Tractor Only	2 (14)	3 (21)
Truck or Tractor w/Single Trailer	3 (21)	4 (28)
Truck or Tractor w/Two Trailers	5 (35)	6 (42)

**Table 11.4, Maximum Allowable Service Brake Air Leakage**

26. *Test the service brakes.*

When starting to move the vehicle and before picking up speed, test the brakes with the foot pedal and parking brake control valve (yellow knob) to be sure they will bring the vehicle to a safe stop.

# Pretrip and Post-Trip Inspections and Maintenance

## Weekly Post-Trip Inspection and Maintenance

### WARNING

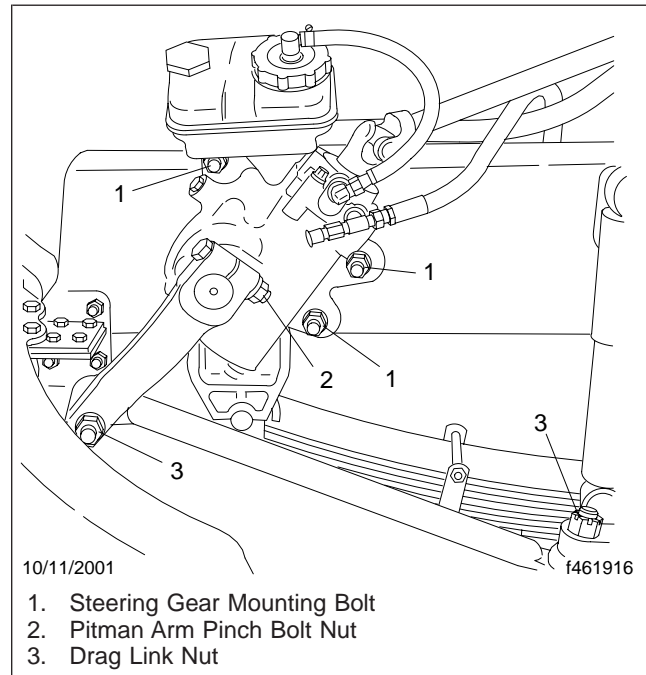
Battery posts, terminals, and related accessories contain lead and lead compounds, chemicals known to the State of California to cause cancer and reproductive harm. To prevent possible personal injury, always wash your hands after handling battery parts and related accessories.

1. *Inspect the batteries and battery cables.*
  - 1.1 Access the batteries. Be sure the battery hold-down is secure. If it is loose, tighten the hold-down bolts; if it is broken, replace it.
  - 1.2 If the battery is equipped with a built-in hydrometer, examine the hydrometer. If a green dot shows in the sight glass, the battery is sufficiently charged.  
  
If the sight glass is dark, the charge is low and the battery must be recharged.  
  
If the sight glass is clear, the battery has a low level of electrolyte and must be replaced.

2. *Check the level of the wheel bearing lubricant in the hub cap at each end of the front axle.*  
  
If needed, fill the hubs to the level indicated on the hub cap. See **Group 35** of the *Acterra® Maintenance Manual*, for recommended lubricants.

**IMPORTANT:** Before removing the fill plug, always clean the hub cap and plug.

3. *Examine the steering components.*  
  
See **Fig. 11.11**. If repairs are needed, see **Group 46** of the *Acterra® Workshop Manual* for instructions, or take the vehicle to an authorized Sterling dealer.
  - 3.1 Check the mounting bolts and pitman arm nut for tightness.
  - 3.2 Check the drag link nuts for missing cotter pins.
  - 3.3 Inspect the steering drive shaft and steering linkage for excessive looseness, or other damage.



**Fig. 11.11, Steering Gear Fasteners**

- 3.4 Tighten loose nuts and have damaged parts replaced as needed.
4. *Check the condition of the serpentine drive belt.*  
  
Look for signs of glazing, wear (frayed edges), damage (breaks or cracks), or oil contamination. If a belt is glazed, worn, damaged, or oil soaked, have the belt replaced, following the instructions in **Group 01** of the *Acterra® Workshop Manual*.
5. *Check the drive belt for proper tension.*  
  
Use your index finger to apply force at the center of the belt free-span. See **Fig. 11.12**. There is no adjustment for belt tension on engines with automatic belt tensioners. If there is not proper tension, have the belt tensioner replaced. See **Group 01** of the *Acterra® Workshop Manual* for instructions, or take the vehicle to an authorized Sterling dealer.
6. *Inspect the seat belts and tether belts.*

### WARNING

**Inspect and maintain seat belts as instructed below. Worn or damaged seat belts could fail**

# Pretrip and Post-Trip Inspections and Maintenance

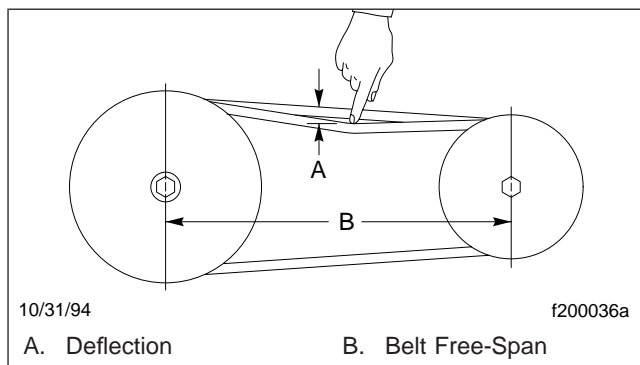


Fig. 11.12, Checking Belt Tension

during a sudden stop or crash, possibly resulting in serious injury or death.

**IMPORTANT:** Seat belts have a finite life which may be much shorter than the life of the vehicle. Regular inspections and replacement as needed are the only assurance of adequate seat belt security over the life of the vehicle.

**NOTE:** When any part of a seat belt needs replacement, the entire seat belt must be replaced, both retractor and buckle side.

- 6.1 Check the web for fraying, cuts, or extreme wear, especially near the buckle latch plate and in the D-loop guide area.
- 6.2 Check the web for extreme dirt or dust and for severe fading from exposure to sunlight.
- 6.3 Check the buckle and latch for operation and for wear or damage.
- 6.4 Check the Komfort Latch for function and cracks or other damage.
- 6.5 Check the web retractor for function and damage.
- 6.6 Check the mounting bolts for tightness and tighten any that are loose.

## Monthly Post-Trip Inspection and Maintenance

### **⚠ WARNING**

Battery posts, terminals, and related accessories contain lead and lead compounds, chemicals known to the State of California to cause cancer and reproductive harm. To prevent possible personal injury, always wash your hands after handling battery parts and related accessories.

1. *Clean the batteries.*
  - 1.1 Remove any corrosion from the hold-down and the top of the battery.

### **⚠ CAUTION**

Take care to keep the vent plugs tight so that the neutralizing solution does not enter any of the battery cells and damage the battery.

- 1.2 Use a soda solution to neutralize the acid present, then rinse off the soda solution with clean water.
- 1.3 If the battery posts or cable terminals are corroded, disconnect the terminals from the posts. Clean them with a soda solution and a wire brush. After cleaning, connect the terminals to the battery posts, then apply a thin coat of petroleum jelly to the posts and terminals to help retard corrosion.
2. *Inspect the radiator and heater hoses, including the clamps and support brackets.*
  - 2.1 Make sure the radiator inlet and outlet hoses are pliable and are not cracking or ballooning. Replace hoses that show signs of cracking, weakening, or ballooning.
  - 2.2 Make sure the heater hoses are pliable and are not cracking or ballooning. Replace hoses that show signs of cracking, weakening, or ballooning.
  - 2.3 Tighten hose clamps as necessary, but do not overtighten, as hose life can be adversely affected.

# Pretrip and Post-Trip Inspections and Maintenance

---

- 2.4 Be sure the hose support brackets are securely fastened. Make sure the hoses are not located near sources of wear, abrasion, or high heat.

**IMPORTANT:** Replace all hoses, including heater hoses, at the same time. Service-type knitted or braided yarn-reinforced neoprene hose is acceptable. Silicone hoses having an extended service life can be substituted for the reinforced neoprene type. See the Freightliner *Service Parts Catalog* or contact your Sterling Dealer.

### 3. *Check the steering wheel for excessive play.*

- 3.1 Start the engine. With the front tires straight ahead, turn the steering wheel until motion is observed at the front wheels.
- 3.2 Align a reference mark on a ruler, then slowly turn the steering wheel in the opposite direction until motion is again detected at the wheels.
- 3.3 Check the lash (free play) at the rim of the steering wheel. See local/federal regulations for acceptable ranges of lash.  
  
If there is excessive lash, check the steering system for wear or incorrect adjustment of the linkage and steering gear before operating the vehicle.

### 4. *Check the brake lining wear on all vehicles, including those with automatic slack adjusters. Proper brake operation is dependent on periodic maintenance and inspection of the brake linings.*

- 4.1 Check that brake linings are free of oil and grease.
- 4.2 Inspect the thickness of the brake linings. If the axle assembly is equipped with a dust shield or backing plate, remove the inspection plugs. If *any* brake linings are worn to less than approximately 1/4 inch (6.4 mm) at the thinnest point, have the linings replaced on *all* brake assemblies on that axle. See **Group 42** of the *Acterra® Workshop Manual* for lining replacement instructions and camshaft end-play inspection.

- 4.3 Check the brake drums for wear and cracks.
- 4.4 Check that the inspection plugs in the dust shields or backing plates, if so equipped, are installed.

# 12

## Cab Appearance

---

Cab Washing and Polishing .....	12.1
Care of Fiberglass Parts .....	12.1
Care of Chrome Parts .....	12.1
Dashboard Care .....	12.1
Vinyl Upholstery Cleaning .....	12.1
Velour Upholstery Cleaning .....	12.2



# Cab Appearance

---

## Cab Washing and Polishing

To protect the finish of your new vehicle, follow these guidelines carefully:

- During the first 30 days, rinse your vehicle frequently with water. If the vehicle is dirty, use a mild liquid soap. Do not use detergent.
- During the first 30 days, do not use anything abrasive on your vehicle. Brushes, chemicals, and cleaners may scratch the finish.
- During the first 120 days, do not wax your vehicle.

To extend the life of your vehicle's finish, follow these guidelines:

- Avoid washing your vehicle in the hot sun. Always use water. After the cab is completely washed, dry it with a towel or chamois.
- Do not dust painted surfaces with a dry cloth, as this will scratch the paint.
- Do not remove ice or snow from a painted surface with a scraper of any sort.
- To prevent damage to the finish, wax it regularly. If the finish has become dull, before waxing, remove oxidized paint using a cleaner specifically designed for this purpose. Remove all road tar and tree sap before waxing. Sterling recommends that a quality brand of cleaner or cleaner-polish and polishing wax be used.
- Do not let diesel fuel or antifreeze stand on a painted surface. If either should occur, rinse the surface off with water.
- To prevent rust, have any nicks or other damage on the finish touched up as soon as possible.
- Park your vehicle in a sheltered area whenever possible.

## Care of Fiberglass Parts

Wash unpainted fiberglass air fairings and shields monthly with a mild detergent, such as dishwashing liquid. Avoid strong alkaline cleansers.

Apply a wax specifically designed for fiberglass.

## Care of Chrome Parts

To prevent rust, keep chrome parts clean and protected at all times. This is especially important during winter driving and in coastal areas where there is exposure to salt air.

When cleaning chrome parts, use clean water and a soft cloth or sponge. A mild detergent may also be used.

Sponge gently, then rinse. If necessary, use a non-abrasive chrome cleaner to remove stubborn rust or other material. Do not use steel wool.

To help protect the chrome after cleaning, apply a coat of polishing wax to the surface. Never use wax on parts that are exposed to high heat, such as exhaust pipes.

## Dashboard Care

Periodically wipe the dashboard with a water-dampened cloth. A mild detergent can be used, but avoid using strong detergents.



### CAUTION

**Do not use Armor-All Protectant®, STP Son-of-a-Gun®, or other equivalent treatments. These cleaners contain vinyl plasticizers that can cause stress crazing in the interior plastic panels, which can result in cracking of the panels.**

## Vinyl Upholstery Cleaning

To prevent soiling, frequent vacuuming or light brushing to remove dust and dirt is recommended. Harsh cleaning agents can cause permanent damage to vinyl upholstery. To preserve the upholstery and prevent damage, carefully review the following sections for recommended cleaning procedures. Waxing or refinishing improves soil resistance and cleanability for all vinyls. Any hard wax, such as that used on automobiles, may be used.

## Ordinary Dirt

Wash the upholstery with warm water and mild soap, such as saddle or oil soap. Apply soapy water to a large area and allow to soak for a few minutes, then rub briskly with a cloth to remove the dirt. This can be repeated several times as necessary.

If dirt is deeply imbedded, use a soft bristle brush after applying the soap.

If dirt is extremely difficult to remove, wall-washing preparations normally found around the home can be used. Powdered cleaners, such as those used for sinks and tiles, are abrasive and must be used with caution as they can scratch the vinyl or give it a permanent dull appearance.

## Chewing Gum

Harden the gum with an ice cube wrapped in a plastic bag, then scrape it off with a dull knife. Any remaining traces of gum can be removed with an all-purpose light oil (peanut butter will also work) and wiped off.

## Tars, Asphalts, and Creosote

Tars, asphalts, and creosote stain vinyl after prolonged contact. They should be wiped off immediately and the area carefully cleaned, using a cloth dampened with naphtha.

## Paint, Shoe Heel Marks

Paint should be removed immediately. Do not use paint remover or liquid-type brush cleaner on vinyl. An unprinted cloth, dampened with naphtha or turpentine may be used. Use care to prevent contact with parts of the upholstery that are not vinyl.

## Sulfide Stains

Sulfide compounds, such as those found in eggs and some canned goods, can stain after prolonged contact with vinyl. These stains can be removed by placing a clean, unprinted piece of cloth over the spotted area and pouring a liberal amount of 6 percent hydrogen peroxide onto the cloth. Allow the saturated cloth to remain on the spot for 30 to 60 minutes. For stubborn spots, allow the hydrogen-peroxide saturated cloth to remain on the area overnight. Use caution to prevent the solution from seeping into the seams or it will weaken the cotton thread.

## Nail Polish and Nail Polish Remover

Prolonged contact with these substances causes permanent damage to vinyl. Careful blotting immediately after contact minimizes damage. Do not spread the liquid during removal.

## Shoe Polish

Most shoe polishes contain dyes which penetrate vinyl and stain it permanently. Shoe polish should be wiped off as quickly as possible using naphtha or lighter fluid. If staining occurs, try the procedure used for sulfide stains.

## Ball Point Ink

Ball point ink can sometimes be removed if rubbed immediately with a damp cloth, using water or rubbing alcohol. If this does not work, try the procedure used for sulfide stains.

## Miscellaneous

If stains do not respond to any of the treatments described above, it is sometimes helpful to expose the vinyl to direct sunlight for up to 30 hours. Mustard, ball point ink, certain shoe polishes, and dyes often bleach out in direct sunlight leaving the vinyl undamaged.

## Velour Upholstery Cleaning

To prevent soiling, frequent vacuuming or light brushing to remove dust and dirt is recommended. Spot clean with a mild solvent or an upholstery shampoo, or the foam from a mild detergent. When using a solvent or a dry-cleaning product, follow the instructions carefully and clean only in a well-ventilated area. Avoid any product that contains carbon tetrachloride or other toxic materials. With either method, pretest a small area before proceeding. Use a professional upholstery cleaning service when extensive cleaning is needed.

## Grease and Oil-Based Stains

Dampen a small absorbent cloth with dry-cleaning solvent or spot remover. Apply the cloth carefully to the spot from the outer edge to the center. Pat and blot the spot with a clean, dry cloth. Repeat several times, as necessary, turning the cloths so that the stain does not redeposit on the fabric.

## Sugar and Water-Based Stains

Apply water-based detergent or cleaner, working in circular motions. Pat and blot as dry as possible. Repeat if necessary before drying thoroughly.

# Cab Appearance

---

## Chewing Gum or Wax

Harden the gum or wax with an ice cube wrapped in a plastic bag, then scrape it off with a dull knife. Excess wax can be absorbed by placing a thick white blotter over the wax and heating with a warm (not hot) iron. Remove the remainder by using the procedure for grease and oil-based stains.

## Mildew

Brush the dry fabric with a soft brush. Sponge with detergent, and blot. If the fabric is colorfast, dilute a teaspoon of bleach in one quart (one liter) of cool water. Apply with a swab, directly on the mildew stain. Dab repeatedly with clear, cool water, and blot dry.

# 13

## In an Emergency

---

Hazard Warning Lights .....	13.1
Fire Extinguisher .....	13.1
Emergency Kit, Optional .....	13.1
Emergency Starting With Jumper Cables .....	13.1
Towing .....	13.2
Fire in the Cab .....	13.4

# In an Emergency

---

## Hazard Warning Lights

The hazard warning lights switch is located either on the turn signal lever or on top of the steering column. Press the switch to turn on the hazard warning lights. Press the switch again to turn off the hazard warning lights.

## Fire Extinguisher

A fire extinguisher is located in the cab by the driver's door.

## Emergency Kit, Optional

An optional emergency kit is located in the cab. The kit includes one or more of the following: a first aid kit, a reflective vest, a triangular reflector, and a flare kit.

If there is an emergency while driving, cautiously pull off the road. Turn on the hazard warning lights. Place the flares and reflector along the side of the road to alert other drivers that an emergency situation exists.

### WARNING

**Use extreme care when placing flares in emergency situations that involve exposure to flammable substances such as fuel. An explosion or fire could occur causing serious personal injury.**

## Emergency Starting With Jumper Cables

When using jumper cables, use the following instructions.

### WARNING

**Batteries release explosive gas. Do not smoke when working around batteries. Put out all flames and remove all sources of sparks or intense heat in the vicinity of the battery. Do not allow the vehicles to touch each other. Do not lean over the batteries when making connections, and keep all other persons away from the batteries. Failure to follow these precautions could lead to severe personal injury as a result of an explosion or acid burns.**

### CAUTION

**Make sure both starting systems have the same voltage outputs, and avoid making sparks. Otherwise the vehicle charging systems could be severely damaged. Also, do not attempt to charge isolated, deep-cycle batteries with jumper cables. Follow the battery manufacturer's instructions when charging deep-cycle batteries.**

On vehicles equipped with optional jump-start posts, attach the positive cable clamp to the positive post instead of to the battery, and attach the negative cable clamp to the negative post.

### CAUTION

**Connecting the jumper cables to the vehicle frame rail or to the engine block can cause severe damage to the engine wiring.**

On vehicles without jump-start posts, the positive cable clamp can be attached to the starter positive lug terminal.

1. Apply the parking brakes and turn off the lights and all other electrical loads.
2. Connect an end of one jumper cable to the positive terminal of the booster battery (or jump-start post if equipped) and connect the other end of the cable to the positive terminal of the discharged battery (or jump-start post if equipped).

### WARNING

**Do the next step exactly as instructed and do not allow the clamps of one cable to touch the clamps of the other cable. Otherwise, a spark could occur near a battery, possibly resulting in severe personal injury from explosion and acid burns.**

3. Connect one end of the second jumper cable to the negative terminal of the booster battery and connect the other end to the negative jump-start post or the starter ground lug. The starter ground lug ([Fig. 13.1](#)) is the best location. Do *not* use the frame rail or the engine block as a ground.

NOTE: It may be easier to access the starter ground lug by routing the jumper cable underneath the vehicle. If the starter ground lug is not

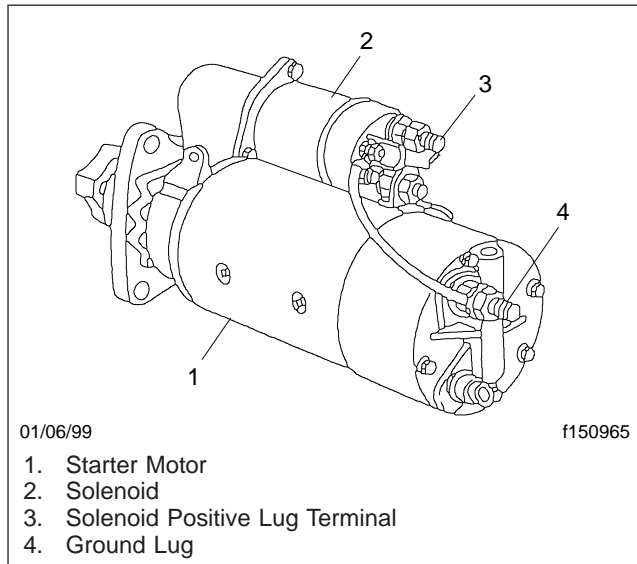


Fig. 13.1, Delco Remy 42-MT Starter

accessible, connect to the negative battery post of the discharged battery.

## ⚠ WARNING

**On vehicles with Mercedes-Benz AGS transmissions, make sure the current gear indicator displays "N" before starting the vehicle. If the transmission starts in gear, it could cause an accident resulting in death, serious personal injury, or property damage.**

4. Start the engine of the vehicle with the booster batteries and let the engine run a few minutes to charge the batteries of the other vehicle.
5. Attempt to start the engine of the vehicle with the batteries receiving the charge. Do not operate the starter longer than 30 seconds, and wait at least two minutes between starting attempts to allow the starter to cool.
6. When the engine starts, let it idle a few minutes.

## ⚠ WARNING

**Do the next step exactly as instructed and do not allow the clamps of one cable to touch the clamps of the other cable. Otherwise, a spark could occur near a battery, possibly resulting in**

**severe personal injury from explosion and acid burns.**

7. Disconnect the grounded cable from the vehicle, then disconnect the other end of the cable from the negative terminal of the booster battery.
8. Disconnect the remaining cable from the newly charged battery or jump-start post first, then disconnect the other end.

## Towing

When it is necessary to tow the vehicle, make sure the instructions below are closely followed to prevent damage to the vehicle.

## ⚠ WARNING

**Do not tow an unbraked vehicle if the combined weight of both vehicles is more than the sum of the gross axle weight ratings (GAWR) of the towing vehicle. Otherwise brake capacity will be inadequate, which could result in personal injury or death.**

## Front Towing Hookup

1. Disconnect the battery ground cables.

## ⚠ CAUTION

**Failure to remove the axle shafts when towing the vehicle with the rear wheels on the ground could result in damage to the transmission and other parts.**

2. Remove both drive axle shafts. On dual drive axles, if the vehicle is to be lifted and towed, remove only the rearmost drive axle shafts.  
  
On vehicles equipped with an air fairing, remove both the forward and rearmost drive axle shafts if there is insufficient towing clearance.
3. Cover the ends of the hubs with metal plates or plywood cut to fit the axle opening, and drilled to fit the axle shaft studs. This prevents lubricant from leaking out and will keep contaminants from getting into and damaging the wheel bearings and axle lubricant.

# In an Emergency

---

## CAUTION

**Failure to protect the frame rails from the chains could cause damage, leading to eventual frame failure.**

4. On dual drive axles, if the vehicle is to be lifted and towed, chain the forward rear-axle assembly to the vehicle frame. Use protection to keep the chains from damaging the frame.
5. Remove the bumper extension and chrome bumper if equipped. Remove the bumper fairing if equipped.
6. On vehicles equipped with an air fairing, adjust the trim tab to the lowest position.

## CAUTION

**Do not pass a sling (for example, a rope or chain) from one tow hook to another to fasten for towing (see Fig. 13.2). Known as reeving, this practice is *not* permissible in most industrial applications of towing and hoisting. Reeving can overload the hooks and result in damage to the vehicle.**

7. Attach the towing device. Due to the many variables that exist in towing, positioning the lifting and towing device is the sole responsibility of the towing-vehicle operator.
8. On vehicles equipped with an air fairing, measure the distance from the ground to the bumper, or from the ground to a frame bracket.
9. Lift the vehicle and secure the safety chains. If extra towing clearance is needed, remove the front wheels.

## WARNING

**Failure to lower the vehicle could result in the air fairing striking an overhead obstruction, such as a bridge or overpass, and causing vehicle damage or personal injury.**

10. On vehicles equipped with an air fairing, repeat the measurement taken in step 8. The difference between the two measurements must not exceed 14 inches (36 cm). If necessary, lower the vehicle.

11. Connect the clearance lights, taillights, and signal lights. Connect any special towing lights required by local regulations.

## WARNING

**Failure to chock the tires or connect the tow truck's air brake system before releasing the spring parking brakes could allow the disabled vehicle to suddenly roll. This could cause property damage or personal injury.**

12. Chock the tires on the disabled vehicle and connect the towing vehicle's air brake system to the vehicle being towed. Then, release the spring parking brakes and remove the chocks.

## Rear Towing Hookup

### CAUTION

**Using a rear towing hookup on a vehicle equipped with a roof fairing could cause damage to the cab structure.**

1. Place the front tires straight forward and secure the steering wheel in this position.
2. Disconnect the battery ground cables.

### CAUTION

**Failure to protect the frame rails from the chains could cause damage, leading to eventual frame failure.**

3. On dual drive axles, using protection to keep the chains from damaging the vehicle frame, chain the forward-rear drive axle to the frame.
4. Attach the towing device. Due to the many variables that exist in towing, positioning the lifting and towing device is the sole responsibility of the towing-vehicle operator.
5. Lift the vehicle and secure the safety chains. If extra clearance is needed, remove the bumper extension if equipped.
6. Connect the clearance lights, taillights, and signal lights. Also connect any special towing lights required by local regulations.

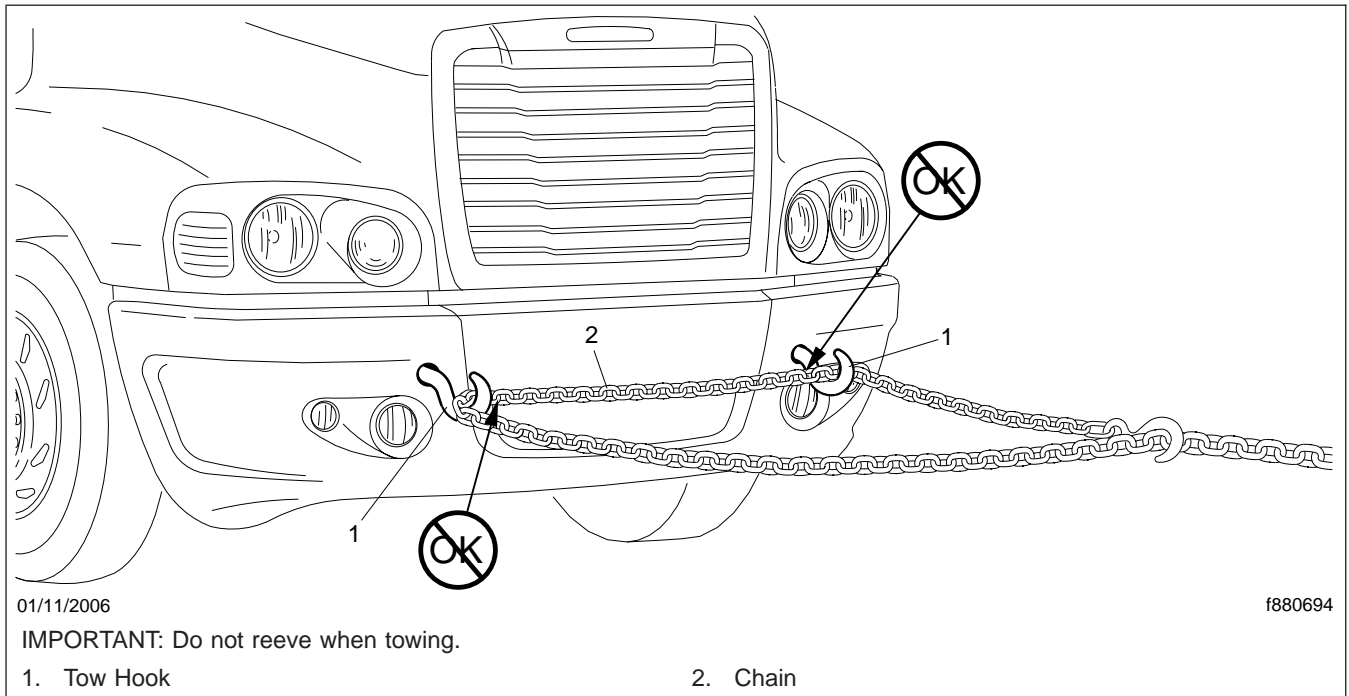


Fig. 13.2, Reeving

## Fire in the Cab

The incidence of fire in medium-duty trucks is rare, according to data from the National Highway Traffic Safety Administration. Federal Motor Vehicle Safety Standard #302 limits the flammability of specified materials used inside the cab, but despite this, most materials will burn. The cab of this vehicle contains urethane foam, which is of concern in this respect.

### **WARNING**

**Urethane foam is flammable! Do not allow any flames, sparks, or other heat sources such as cigarettes or light bulbs to contact urethane foam. Urethane foam in contact with such heat sources could cause a serious, rapid fire, which could result in death, severe burns, or gas poisoning, as well as damage to the vehicle.**

## In Case of a Cab Fire

As quickly as possible, bring the vehicle to a safe stop, apply the parking brake, turn off the ignition, and get out of the vehicle.



# Index

Subject	Page	Subject	Page
<b>A</b>			
Air Brake System	6.1	Exiting the Driver's Side When There is One Cab Access Step	3.3
Automatic Slack Adjusters	6.5	Exiting the Passenger's Side When There are Two Cab Access Steps	3.3
General Information	6.1	Exiting the Passenger's Side When There is One Cab Access Step	3.4
Meritor™ WABCO® Antilock Braking System (ABS), Air Brake Systems	6.3	Cab Washing and Polishing	12.1
Operation	6.2	Canadian Motor Vehicle Safety Standard (CMVSS) Labels	1.2
Air Conditioning, Optional	4.2	Care of Chrome Parts	12.1
Allison AT/MT Series		Care of Fiberglass Parts	12.1
Transmissions	8.22	Clutches	7.15
Allison AT 500 Series	8.22	Clutch Adjustments	7.17
Allison MT 600 Models	8.23	Clutch Operation	7.16
Allison MD Series		General Information	7.15
Transmissions	8.19	Lubrication	7.17
Operating Instructions, MD Series	8.19	Cold-Weather Operation	7.9
Safety Precautions	8.19	Caterpillar	7.10
Allison On-Highway		Cummins	7.10
Transmissions	8.16	Mercedes-Benz	7.9
Operating Instructions, On- Highway Transmissions	8.17	Cold-Weather Starting	7.5
Range Inhibit Indicator, 2000 and 2400 Series	8.17	Caterpillar	7.5
Safety Precautions, On- Highway Transmissions	8.16	Cummins	7.6
		Mercedes-Benz	7.5
<b>B</b>			
Back-of-Cab Grab Handles, Steps, and Deck Plate	3.4	<b>D</b>	
Accessing Back-of-Cab Area	3.5	Dashboard Care	12.1
Exiting the Back-of-Cab Area	3.5	Defogging and Defrosting Using Fresh Air	4.1
<b>C</b>			
Cab Door Locks and Handles	3.1	Door Windows	3.1
Cab Entry and Exit	3.2	<b>E</b>	
Entering the Driver's Side When There are Two Cab Access Steps	3.2	Eaton Fuller AutoShift Automated Transmissions	8.1
Entering the Driver's Side When There is One Cab Access Step	3.3	General Information, AutoShift	8.1
Entering the Passenger's Side When There are Two Cab Access Steps	3.3	Operation, SmartShift With Eaton Fuller AutoShift	8.3
Entering the Passenger's Side When There is One Cab Access Step	3.3	Eaton Fuller Deep-Reduction Transmissions	8.13
Exiting the Driver's Side When There are Two Cab Access Steps	3.2	General Information, Deep Reduction	8.13
		Operation, Deep Reduction	8.13
		Eaton Fuller Range-Shift Transmissions	8.11
		General Information, Range- Shift	8.11
		Operation, Range-Shift	8.12

<b>Subject</b>	<b>Page</b>	<b>Subject</b>	<b>Page</b>
Eaton Fuller Straight-Shift Transmissions	8.10	Fontaine® Fifth Wheels	10.3
General Information, Straight-Shift	8.10	6000/7000 Series No-Slack® II Stationary Models	10.3
Operation, Straight-Shift	8.10	Fifth Wheel Lock Mechanism for Trailer Kingpin	10.3
Eaton Fuller UltraShift™	8.5	Fifth Wheel Locking Operation	10.4
General Information, UltraShift ASW	8.5	Freightliner SmartShift Shift Control	8.1
Operation, UltraShift ASW	8.5	Fresh Air	4.2
Ultrashtif Diagnostics	8.9	Fuse, Relay, and Circuit Breaker Identification	3.5
Emergency Kit, Optional	13.1		
Emergency Starting With Jumper Cables	13.1	<b>H</b>	
Engine Braking System, Optional	7.15	Hazard Warning Lights	13.1
Mercedes-Benz Engine Brake/Constant-Throttle Valves	7.15	Heating	4.2
Engine Break-In	7.6	High-Altitude Operation	7.13
Engine Operation	7.6	Holland Fifth Wheels	10.1
Caterpillar	7.8	3500 Series Stationary Models	10.1
Cummins	7.9	Fifth Wheel Locking Operation	10.1
Engine Protection	7.6	Hood Tilting	3.4
Mercedes-Benz	7.7	To Return the Hood	3.4
Engine Shutdown	7.11	To Tilt the Hood	3.4
Caterpillar	7.12	HVAC General Information	4.1
Cummins	7.12	Hydraulic Brake System	6.5
Mercedes-Benz	7.11	General Information	6.5
Engine Starting	7.2	Meritor™ WABCO® Antilock Braking System (ABS), Hydraulic Brake Systems	6.6
Caterpillar	7.4	Operation	6.6
Cummins	7.5		
Mercedes-Benz	7.4	<b>I</b>	
Pre-Start	7.3	Instrument and Control Panel	2.1
Starting Precautions, All Engines	7.3	ABS Diagnostic Switch, Optional	2.8
EPA Emission Control	1.2	Aftertreatment System (ATS) Request/Inhibit Regen Switch	2.8
EPA07 Exhaust Emissions	1.2	Axle Controls	2.6
Vehicle Noise Emission Control Label	1.2	Battery-Isolation Switch	2.10
EPA07 Aftertreatment System (ATS)	7.1	Cruise Control	2.9
Exhaust Braking System, Optional	7.13	Daytime Running Lights, Optional	2.3
General Information	7.13	Engine Brake Controls	2.8
Pacbrake® Exhaust Brake	7.14	Headlight and Parking Light Switch	2.3
		Heater and Air-Conditioner Controls	2.5
<b>F</b>		Horn	2.5
Federal Motor Vehicle Safety Standard (FMVSS) Labels	1.1	Hot Posts	2.6
Fire Extinguisher	13.1		
Fire in the Cab	13.4		
In Case of a Cab Fire	13.4		

# Index

---

Subject	Page
Ignition Switch and Key	2.1
Instrument and Control	
Panel Dimmer Switch	2.3
Marker Blink Switch	2.3
Mirror Controls	2.2
Mode/Reset Switch, Optional	2.6
Parking-Brake-Control Valve	2.5
Power Lock Switch, Optional	2.2
Power Window Switch, Optional	2.1
Tilt, or Tilt and Telescoping Steering Wheel, Optional	2.5
Trailer-Air-Supply Valve	2.5
Trailer-Brake Hand-Control- Valve Lever	2.5
Transmission Controls	2.10
Turn Signal Lever, Signal- Stat	2.4
Turn Signal Lever, United Technologies	2.3
Instrumentation Control Unit 3 (ICU3 and ICU3 '07)	2.21
ICU3 Ignition Sequence	2.21
Mode/Reset Switch	2.23
Instrumentation Control Unit 4 (ICU4)	2.16
Buzzer and Chime	2.17
Ignition Sequence	2.17
Mode/Reset Switch	2.17
Instruments	2.13
Application Air Pressure Gauge, Optional	2.16
Coolant Temperature Gauge	2.14
Engine Oil Pressure Gauge	2.13
Forward and Rear Axle Oil Temperature Gauges, Optional	2.15
Fuel Gauge	2.14
Intake Air Restriction Indicator, Dash-Mounted, Optional	2.16
Intake Air Restriction Indicator	2.16
Primary and Secondary Air Pressure Gauges	2.14
Speedometer	2.13
Tachometer, Optional	2.13
Transmission Oil Temperature Gauge, Optional	2.15
Voltage Reading	2.14

Subject	Page
<b>M</b>	
Mercedes-Benz Automated Transmissions	8.24
AGS Diagnostics	8.29
General Information, AGS	8.24
Operation, AGS	8.25
Mercedes-Benz Manual Transmissions	8.15
Meritor™ Axle Lock Operation	9.2
Meritor™ Drive Axles With Wheel Lock	9.1
Meritor™ Tandem Drive Axles With Axle Lock	9.2
Meritor™ Wheel Lock Operation	9.1
<b>N</b>	
NGI Instrument Cluster, Optional	2.23
Instruments	2.23
Lightbar	2.23
Message Center	2.24
Mode and Set Buttons	2.25
<b>P</b>	
Pretrip and Post-Trip Inspection Checklists	11.1
Pretrip and Post-Trip Maintenance Procedures	11.3
Daily Pretrip Inspection and Maintenance	11.3
Monthly Post-Trip Inspection and Maintenance	11.14
Weekly Post-Trip Inspection and Maintenance	11.13
<b>S</b>	
Seat Belts and Tether Belts	5.5
General Information	5.5
Seat Belt Operation	5.5
Seats	5.1
Bostrom Talladega™ 915 Seat	5.4
EzyRider® Seat	5.2
General Information	5.1
National 2000 Series Seat	5.3
National Nonsuspended Seat	5.3
Two-Passenger Bench Seat	5.5
Starting After an Extended Shutdown or Oil Change	7.6

<b>Subject</b>	<b>Page</b>
Steering System .....	6.1
General Information .....	6.1
Power Steering System .....	6.1

## T

Tire and Rim Labels .....	1.2
Towing .....	13.2
Front Towing Hookup .....	13.2
Rear Towing Hookup .....	13.3
TTC Manual Transmissions .....	8.16
General Information, TTC .....	8.16
Operation, TTC .....	8.16

## V

Vehicle Specification Decal .....	1.1
Velour Upholstery Cleaning .....	12.2
Chewing Gum or Wax .....	12.3
Grease and Oil-Based Stains .....	12.2
Mildew .....	12.3
Sugar and Water-Based Stains .....	12.2
Vinyl Upholstery Cleaning .....	12.1
Ball Point Ink .....	12.2
Chewing Gum .....	12.2
Miscellaneous .....	12.2
Nail Polish and Nail Polish Remover .....	12.2
Ordinary Dirt .....	12.1
Paint, Shoe Heel Marks .....	12.2
Shoe Polish .....	12.2
Sulfide Stains .....	12.2
Tars, Asphalts, and Creosote .....	12.2

## W

Warning and Indicator Lights .....	2.10
Engine Protection Warning Lights .....	2.12