

# Contents

<b>Chapter</b>		<b>Page</b>
	Introduction, Environmental Concerns and Recommendations, Event Data Recorder, Customer Assistance Center, Reporting Safety Defects . . . . .	<b>Foreword</b>
<b>1</b>	Vehicle Identification . . . . .	<b>1.1</b>
<b>2</b>	Vehicle Access and Features . . . . .	<b>2.1</b>
<b>3</b>	Driver Controls and Instruments . . . . .	<b>3.1</b>
<b>4</b>	Engines . . . . .	<b>4.1</b>
<b>5</b>	Transmissions . . . . .	<b>5.1</b>
<b>6</b>	Clutches, Rear Axles, and Steering . . . . .	<b>6.1</b>
<b>7</b>	Brakes . . . . .	<b>7.1</b>
<b>8</b>	Fifth Wheels . . . . .	<b>8.1</b>
<b>9</b>	Pretrip Inspection and Daily Maintenance . . . . .	<b>9.1</b>
<b>10</b>	Cab Appearance . . . . .	<b>10.1</b>
<b>11</b>	In an Emergency . . . . .	<b>11.1</b>
	Index . . . . .	<b>I.1</b>

## Introduction

This manual provides information needed to operate and understand the vehicle and its components. More detailed information is contained in the *Owner's Warranty Information for North America* booklet, and in the vehicle's service and maintenance manuals.

Custom-built Freightliner vehicles are equipped with various chassis and cab components. Not all of the information contained in this manual applies to every vehicle. For details about components in your vehicle, refer to the chassis specification pages included in all new vehicles and to the vehicle specification decal, located inside the vehicle.

For your reference, keep this manual in the vehicle at all times.

**IMPORTANT:** Descriptions and specifications in this manual were in effect at the time of printing. Freightliner LLC reserves the right to discontinue models and to change specifications or design at any time without notice and without incurring obligation. Descriptions and specifications contained in this publication provide no warranty, expressed or implied, and are subject to revisions and editions without notice.

## Environmental Concerns and Recommendations

Whenever you see instructions in this manual to discard materials, you should first attempt to reclaim and recycle them. To preserve our environment, follow appropriate environmental rules and regulations when disposing of materials.

## Event Data Recorder

This vehicle is equipped with one or more devices that record specific vehicle data. The type and amount of data recorded varies depending on how the vehicle is equipped (such as the brand of engine, if an air bag is installed, or if the vehicle features a collision avoidance system, etc.).

## Customer Assistance Center

Having trouble finding service? Call the Customer Assistance Center at 1-800-385-4357 or 1-800-FTL-HELP. Call night or day, weekdays or weekends, for dealer referral, vehicle information, breakdown coordination, or Fleetpack assistance. Our people are knowledgeable, professional, and committed to following through to help you keep your truck moving.

# Foreword

---

## Reporting Safety Defects

If you believe that your vehicle has a defect which could cause a crash or could cause injury or death, you should immediately inform the National Highway Traffic Safety Administration (NHTSA) in addition to notifying Freightliner LLC.

If the NHTSA receives similar complaints, it may open an investigation, and if it finds that a safety defect exists in a group of vehicles, it may order a recall and remedy campaign. However, NHTSA cannot become involved in individual problems between you, your dealer, or Freightliner LLC.

To contact NHTSA, you may either call the Auto Safety Hotline toll-free at 1-800-424-9393 (or 366-0123 if you are in the Washington, D.C. area) or write to: NHTSA, U.S. Department of Transportation, Washington, D.C. 20590. You can also obtain other information about motor vehicle safety from the Hotline.

To contact Transport Canada, either call 1-613-993-9542 or write to: Road Safety and Motor Regulation Directorate, Transport Canada, 330 Sparks Street, Tower C, Ottawa, Ontario, Canada K1A 0N5.

© 1991-2003 Freightliner LLC. All rights reserved.

No part of this publication, in whole or part, may be translated, reproduced, stored in a retrieval system, or transmitted in any form by any means, electronic, mechanical, photocopying, recording, or otherwise, without the prior written permission of Freightliner LLC. For additional information, please contact Freightliner LLC, Service Systems and Documentation, P.O. Box 3849, Portland OR 97208-3849 U.S.A. or refer to <http://www.Freightliner.com> and <http://www.FreightlinerTrucks.com>.

# Contents

<b>Chapter</b>		<b>Page</b>
	Introduction, Environmental Concerns and Recommendations, Event Data Recorder, Customer Assistance Center, Reporting Safety Defects . . . . .	<b>Foreword</b>
<b>1</b>	Vehicle Identification . . . . .	<b>1.1</b>
<b>2</b>	Vehicle Access and Features . . . . .	<b>2.1</b>
<b>3</b>	Driver Controls and Instruments . . . . .	<b>3.1</b>
<b>4</b>	Engines . . . . .	<b>4.1</b>
<b>5</b>	Transmissions . . . . .	<b>5.1</b>
<b>6</b>	Clutches, Rear Axles, and Steering . . . . .	<b>6.1</b>
<b>7</b>	Brakes . . . . .	<b>7.1</b>
<b>8</b>	Fifth Wheels . . . . .	<b>8.1</b>
<b>9</b>	Pretrip Inspection and Daily Maintenance . . . . .	<b>9.1</b>
<b>10</b>	Cab Appearance . . . . .	<b>10.1</b>
<b>11</b>	In an Emergency . . . . .	<b>11.1</b>
	Index . . . . .	<b>I.1</b>

## Vehicle Identification

Vehicle Specification Decal .....	1.1
Federal Motor Vehicle Safety Standard (FMVSS) Labels .....	1.1
Canadian Motor Vehicle Safety Standard (CMVSS) Labels .....	1.2
Tire and Rim Labels .....	1.3
EPA Vehicle Noise Emission Control Label .....	1.3

# Vehicle Identification

## Vehicle Specification Decal

The vehicle specification decal (Fig. 1.1) identifies the vehicle model, I.D. number, and major component models. It also lists the major assemblies and installations shown on the chassis specification sheet. A copy of the specification decal is inside the rear cover of the *Owner's Warranty Information for North America* booklet. An illustration of the decal is shown in Fig. 1.1.

FREIGHTLINER COMPONENT INFORMATION	
MANUFACTURED BY MODEL VEHICLE ID NO.	USE VEHICLE ID NO. WHEN ORDERING PARTS
DATE OF MFR ENGINE MODEL TRANS MODEL MAIN FRONT AXLE MODEL REAR AXLE MODEL	WHEELBASE ENGINE NO. TRANS NO. FRT AXLE NO. REAR AXLE NO. REAR AXLE NO. RATIO
PAINT MFR PAINT NO.	FOR COMPLETE PAINT INFORMATION SEE VEHICLE SPECIFICATION SHEET
PART NO. 24-00273-010	

11/21/96 f080027

Fig. 1.1, Vehicle Specification Decal, U.S.-Built Vehicle Shown

NOTE: Labels shown in this chapter are examples only.

## Federal Motor Vehicle Safety Standard (FMVSS) Labels

NOTE: Due to the variety of FMVSS certification requirements, not all of the labels shown will apply to your vehicle.

Tractors with or without fifth wheels purchased in the U.S. are certified by means of a certification label (Fig. 1.2) and the tire and rim labels. These labels are attached to the left rear door post.

1	2	3
THIS VEHICLE CONFORMS TO ALL APPLICABLE FEDERAL MOTOR VEHICLE SAFETY STANDARDS IN EFFECT ON THE DATE OF MANUFACTURE SHOWN ABOVE. VEHICLE TYPE CLASSIFICATION: TRUCK TRACTOR		
11/21/96 <span style="float: right;">f080053</span>		
<ol style="list-style-type: none"><li>1. Date of manufacture by month and year.</li><li>2. Gross vehicle weight rating; developed by taking the sum of all the vehicle's gross axle ratings.</li><li>3. Gross axle weight ratings; developed by considering each component in an axle system, including suspension, axle, wheels, and tires. The lowest component capacity is the value used for the system.</li></ol>		

Fig. 1.2, Certification Label, U.S.

# Vehicle Identification

If purchased for service in the U.S., trucks built without a cargo body have a certification label (Fig. 1.3) attached to the left rear door post. In addition, after completion of the vehicle, a certification label similar to that shown in Fig. 1.2 must be attached by the final-stage manufacturer. This label will be located on the left rear door post and certifies that the vehicle conforms to all applicable FMVSS regulations in effect on the date of completion.

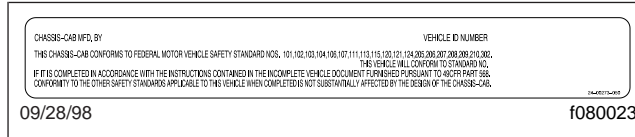

Fig. 1.3, Incomplete Vehicle Certification Label, U.S.

## Canadian Motor Vehicle Safety Standard (CMVSS) Labels

In Canada, tractors with fifth wheels are certified by means of a "Statement of Compliance" label and the Canadian National Safety Mark (Fig. 1.4), which are attached to the left rear door post. In addition, tire and rim labels (Fig. 1.5) are also attached to the left rear door post.

If purchased for service in Canada, trucks built without a cargo body and tractors built without a fifth wheel are certified by a "Statement of Compliance" label, similar to

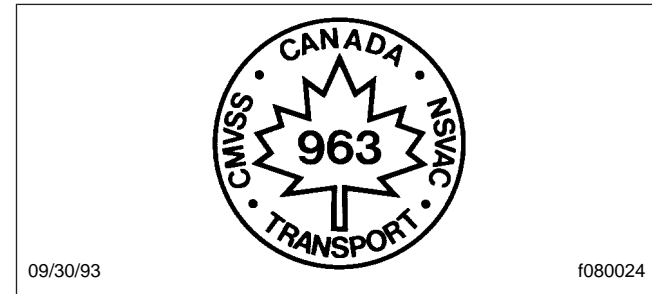

Fig. 1.4, Canadian National Safety Mark

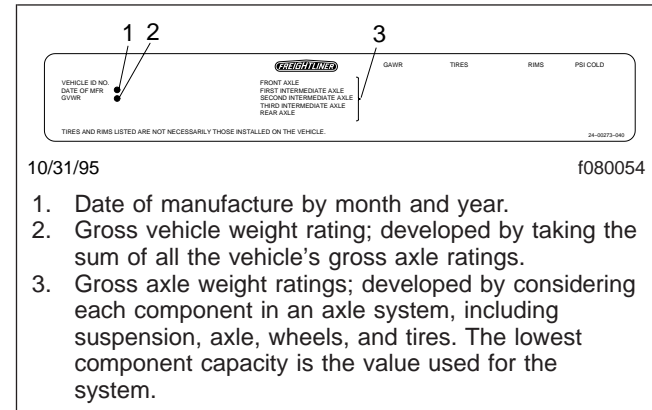

Fig. 1.5, Tire and Rim Label

1. Date of manufacture by month and year.
2. Gross vehicle weight rating; developed by taking the sum of all the vehicle's gross axle ratings.
3. Gross axle weight ratings; developed by considering each component in an axle system, including suspension, axle, wheels, and tires. The lowest component capacity is the value used for the system.

# Vehicle Identification

**Fig. 1.2.** This label must be attached by the final-stage manufacturer after completion of the vehicle. The label is located on the left rear door post, and certifies that the vehicle conforms to all applicable CMVSS regulations in effect on the date of completion.

## Tire and Rim Labels

Tire and rim labels certify suitable tire and rim combinations that can be installed on the vehicle, for the given gross axle weight rating. Tires and rims installed on the vehicle at the time of manufacture may have a higher load capacity than that certified by the tire and rim label. If the tires and rims currently on the vehicle have a lower load capacity than that shown on the tire and rim label, then the tires and rims determine the load limitations on each of the axles.

Refer to **Fig. 1.5** for U.S. and Canadian tire and rim labels.

## EPA Vehicle Noise Emission Control Label

A vehicle noise emission control label (**Fig. 1.6**) is attached to the right rear door post.

It is the owner's responsibility to maintain the vehicle so that it conforms to EPA regulations.

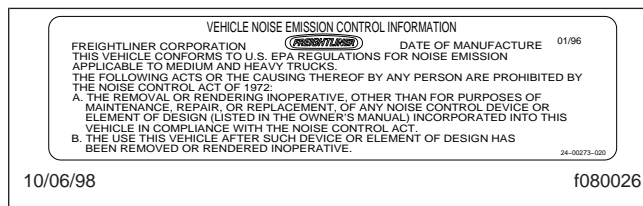

**Fig. 1.6, Vehicle Noise Emission Control Label**

**IMPORTANT:** Certain Freightliner incomplete vehicles may be produced with incomplete noise control hardware. Such vehicles will not have a vehicle noise emission control information label. For such vehicles, it is the final-stage manufacturer's responsibility to complete the vehicle in conformity to U.S. EPA regulations (40 CFR Part 205) and label it for compliance.



## Vehicle Access and Features

Cab Door Locks and Handles .....	2.1
Door Windows .....	2.1
Cab Entry and Exit .....	2.1
Seats .....	2.5
Seat Belts and Tether Belts .....	2.12
Seat Belt Operation .....	2.13
Sleeper Compartment Bunk Restraints .....	2.16
Bunk Mattress .....	2.17
Under Bunk Storage .....	2.17
Fuse/Relay/Circuit Breaker Identification .....	2.17
Hood Tilting .....	2.18
Back-of-Cab Grab Handles, Steps, and Deck Plate .....	2.22

# Vehicle Access and Features

## Cab Door Locks and Handles

The same key that operates the ignition switch is used to lock and unlock the cab doors from the outside.

**IMPORTANT:** Each key is numbered. Record the number so that, if needed, a duplicate key can be made.

To unlock a door from outside the cab, insert the key in the lockset (**Fig. 2.1**) and turn the top of the key toward the front. Pull out on the paddle handle to open the door. To lock the door, turn the top of the key toward the back; the lock cannot be operated when the door is open.

To lock the door from inside the cab, close the door, then push the lock button down. See **Fig. 2.2**.

To open the door from the inside, pull the door latch handle toward you. This will unlatch the door whether or not it was locked. To unlock the door without unlatching it, push up on the bottom of the lock button.

## Door Windows

To lower the driver's side door window, turn the regulator handle clockwise; to lower the passenger's side, turn the handle counterclockwise. See **Fig. 2.2**.

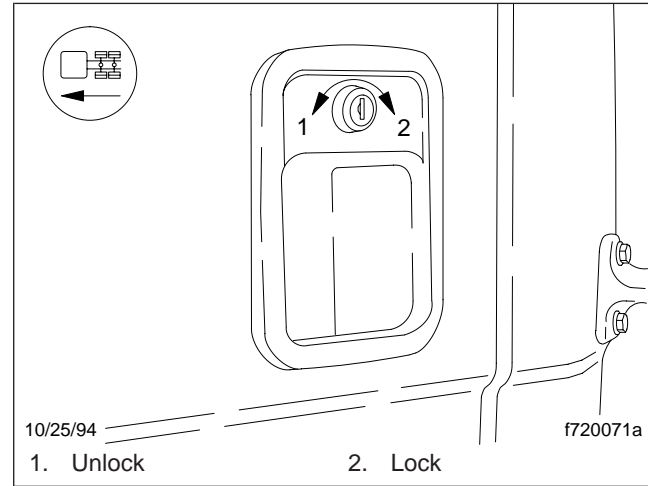

**Fig. 2.1, Exterior Door Handle**

## Cab Entry and Exit



**Wet or dirty shoe soles greatly increase the chance of slipping or falling. If your soles are wet or dirty, be especially careful when entering or exiting the vehicle.**

# Vehicle Access and Features

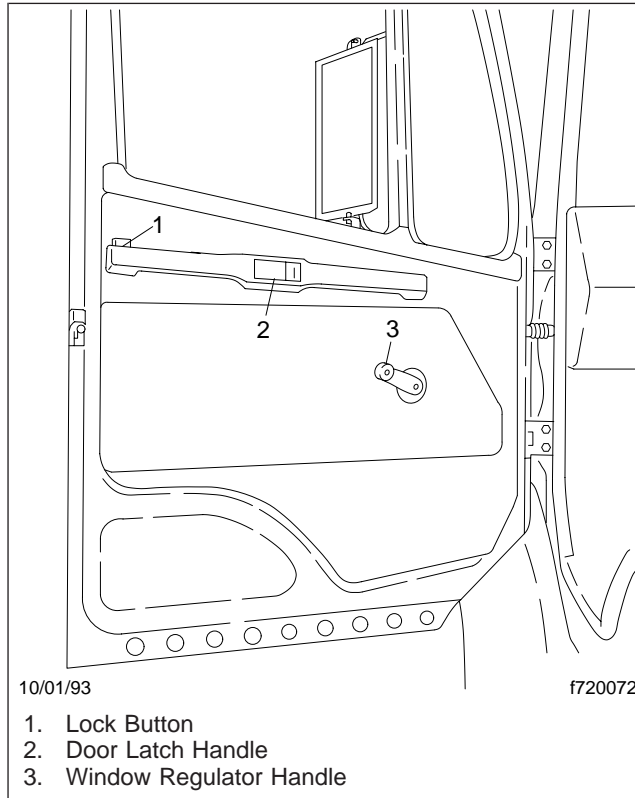

**Fig. 2.2, Door Interior**

**Always maintain three-point contact with the cab access system while entering and exiting the cab. Three-point contact means both feet and one hand, or both hands and one foot.**

When entering or exiting the cab, use the grab handles and access steps as follows (refer to **Fig. 2.3**):

1. Open the driver's door, and place anything that you are carrying in the cab.
2. If the vehicle is equipped with a single access step, do the following:
  - 2.1 Grasp the door grab handle with your left hand and the cab grab handle with your right hand.
  - 2.2 Place your right foot on the cab access step.
  - 2.3 Bring your left foot up to the cab floor, and step up, bringing your right foot into place in the cab.
  - 2.4 To exit the cab on the driver's side, grasp the door grab handle with your left hand.

**IMPORTANT:** Do not attempt to exit the cab while carrying any items in your hand.

- 2.5 Move your left foot to the access step, then reach with your right hand and grasp the cab grab handle.

# Vehicle Access and Features

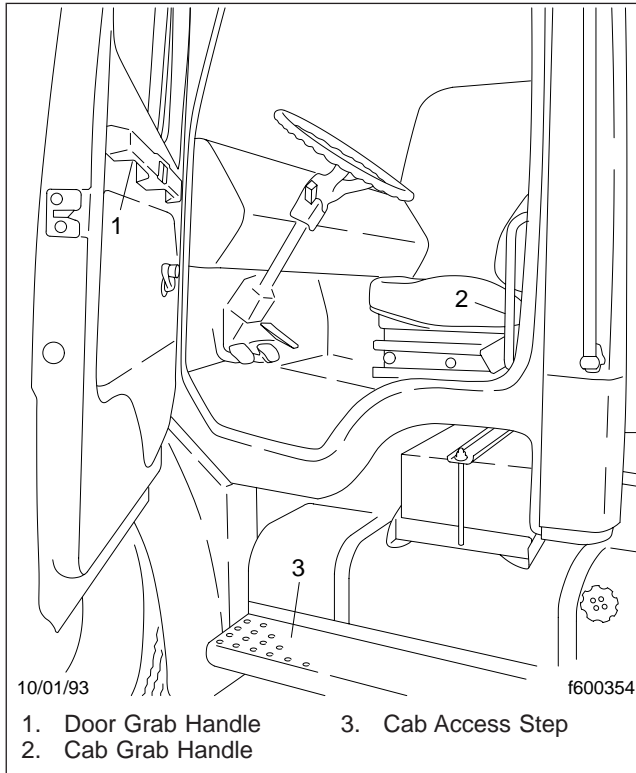

**Fig. 2.3, Driver's Side Step and Grab Handle**

- 2.6 Bring your right foot down to the ground, then bring your left foot down to the ground.

**NOTE:** Enter and exit the cab from the passenger's side, using the same procedures given for entering and exiting the driver's side, but using opposite hands and feet.

3. If the vehicle is equipped with two access steps, do the following:
  - 3.1 Grasp the cab grab handle with your right hand.
  - 3.2 Place your right foot on the lower cab access step.
  - 3.3 Bring your left foot up to the upper access step.
  - 3.4 Grasp the steering wheel with your left hand. Bring your right foot up to the cab floor, and step up, bringing your left foot into place in the cab.
  - 3.5 To exit the cab on the driver's side, grasp the steering wheel with your left hand and stand on the threshold, facing into the cab.

**IMPORTANT:** Do not attempt to exit the cab while carrying any items in your hand.

# Vehicle Access and Features

- 3.6 Move your left foot to the upper access step, then reach with your right hand and grasp the cab grab handle.
- 3.7 Move your right foot to the bottom step.
- 3.8 Step to the ground with your left foot.

**NOTE:** Enter and exit the cab from the passenger's side, using the same procedures given for entering and exiting the driver's side, but using opposite hands and feet. Also, instead of the steering wheel, use the forward grab handle.

4. On right-hand-drive vehicles equipped with a single access step, do the following (see [Fig. 2.4](#)):
  - 4.1 Grasp the door grab handle with your right hand and the cab grab handle with your left hand.
  - 4.2 Place your left foot on the cab access step.
  - 4.3 Bring your right foot up to the cab floor, and step up, bringing your left foot into place in the cab.
  - 4.4 To exit the cab on the driver's side, grasp the door grab handle with your right hand.

**IMPORTANT:** Do not attempt to exit the cab while carrying any items in your hand.

- 4.5 Move your right foot to the access step, then reach with your left hand and grasp the cab grab handle.
- 4.6 Bring your left foot down to the ground, then bring your right foot down to the ground.

**NOTE:** Enter and exit the cab from the passenger's side, using the same procedures given for entering and exiting the driver's side, but using opposite hands and feet.

5. On right-hand-drive vehicles equipped with two access steps, do the following:
  - 5.1 Grasp the cab grab handle with your left hand.
  - 5.2 Place your left foot on the lower cab access step.
  - 5.3 Bring your right foot up to the upper access step.
  - 5.4 Grasp the steering wheel with your right hand. Bring your left foot up to the cab floor, and step up, bringing your right foot into place in the cab.
  - 5.5 To exit the cab on the driver's side, grasp the steering wheel with your right hand and stand on the threshold, facing into the cab.

# Vehicle Access and Features

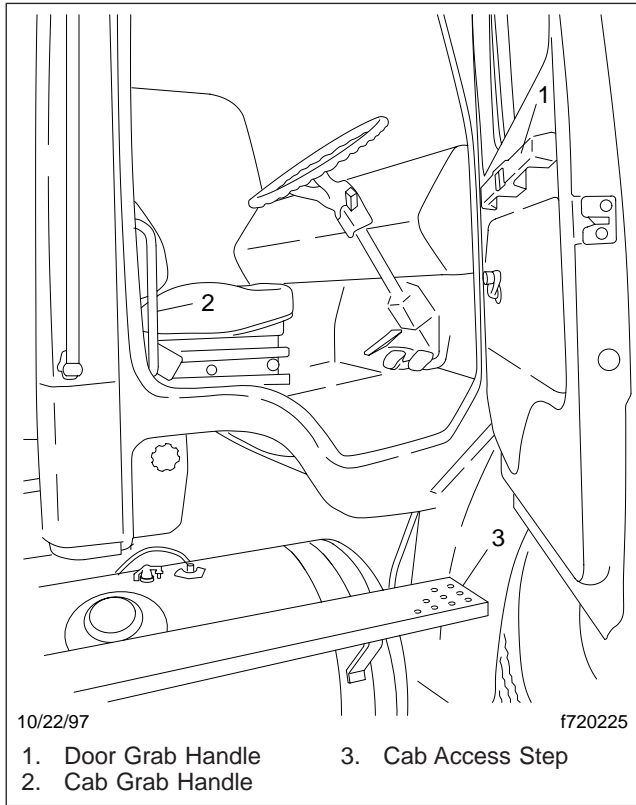

**Fig. 2.4, Driver's-Side Step and Grab Handle (right-hand-drive vehicle)**

**IMPORTANT:** Do not attempt to exit the cab while carrying any items in your hand.

- 5.6 Move your right foot to the upper access step, then reach with your left hand and grasp the cab grab handle.
- 5.7 Move your left foot to the bottom step.
- 5.8 Step to the ground with your right foot.

**NOTE:** Enter and exit the cab from the passenger's side, using the same procedures given for entering and exiting the driver's side, but using opposite hands and feet. Also, instead of the steering wheel, use the forward grab handle.

## Seats

Due to the maximum adjustability of mid- and high-back air suspension seats, it is possible to combine the seat back recline adjustment and the seat slide adjustment so that the seat back contacts the backwall. It is the responsibility of the driver to adjust the seat to prevent damage to the seat and the cab interior.

**IMPORTANT:** When adjusting the seats, unless otherwise noted, make all adjustments while seated and before the engine is started.

## **WARNING**

Keep hands, tools, and other objects away from the scissor points under the seats. Failure to do so could cause personal injury.

### National Cush-N-Aire® Seat (Fig. 2.5)

#### Back Cushion Tilt

To tilt the back cushion through a range of 12 degrees, turn the knob and lean forward or backward.

#### Height Adjustment

Push in the knob to inflate the suspension and raise the seat height. Pull out on the knob to deflate the suspension and lower the seat height.

#### Isolator Lockout, Optional

Called a Chugger-Snubber™, the isolator is locked out by moving the handle down.

#### Fore and Aft Seat Adjustment

Move the lever to the right and slide the seat forward or backward to the desired position.

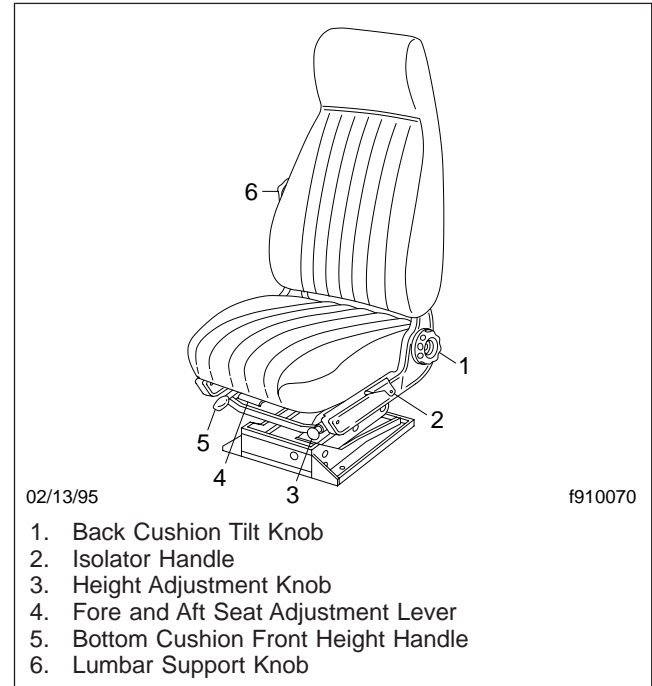

**Fig. 2.5, National Cush-N-Aire Seat**

# Vehicle Access and Features

---

## Bottom Cushion Front Height

To adjust the height of the front of the bottom cushion, lift the handle and pull forward or push back to the desired setting.

## Lumbar Support

Turn the knob for precise fit.

## National Cush-N-Aire II Seat (Fig. 2.6)

### Back Cushion Tilt

To tilt the back cushion, turn the knob and lean forward or backward.

### Height Adjustment

To raise the seat, push the rocker switch on the side of the seat up until the seat reaches the desired height. To lower the seat, push the rocker switch down until the seat reaches the desired height.

### Fore and Aft Seat Adjustment

Move the lever to the left and slide the seat forward or backward to the desired position.

### Bottom Cushion Front Height

To adjust the height of the front of the bottom cushion, lift the handle, and pull forward or push back to the desired setting.

## Lumbar Support

Push the rocker switch on the side of the seat up to inflate lumbar support. Push the rocker switch down to deflate lumbar support.

## Back-of-Cushion Height

To adjust the height at the back of the cushion, rotate the lever to the desired setting.

## Isolator, Optional

Also called a Chugger-Snubber™, the isolator is locked out by moving the handle down.

## National Easy-Aire Seat (Fig. 2.7)

### Back Cushion Tilt

To tilt the back cushion, turn the knob and lean forward or backward.

### Height Adjustment

To raise the seat, push the pump handle down and continue pumping until the seat reaches the desired height. To lower the seat, depress the handle and hold until the seat reaches the desired height.

### Fore and Aft Seat Adjustment

Move the lever to the right and slide the seat forward or backward to the desired position.



# Vehicle Access and Features

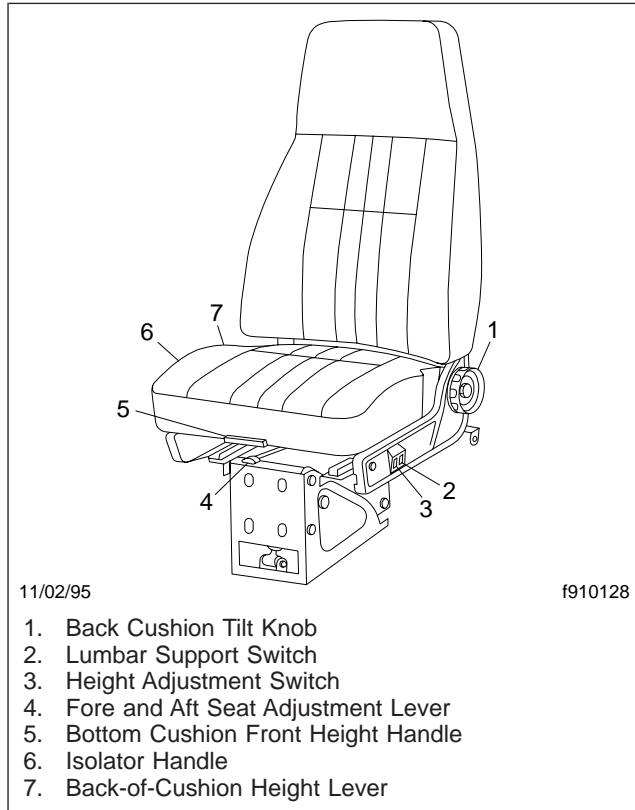

**Fig. 2.6, National Cush-N-Aire II Seat**

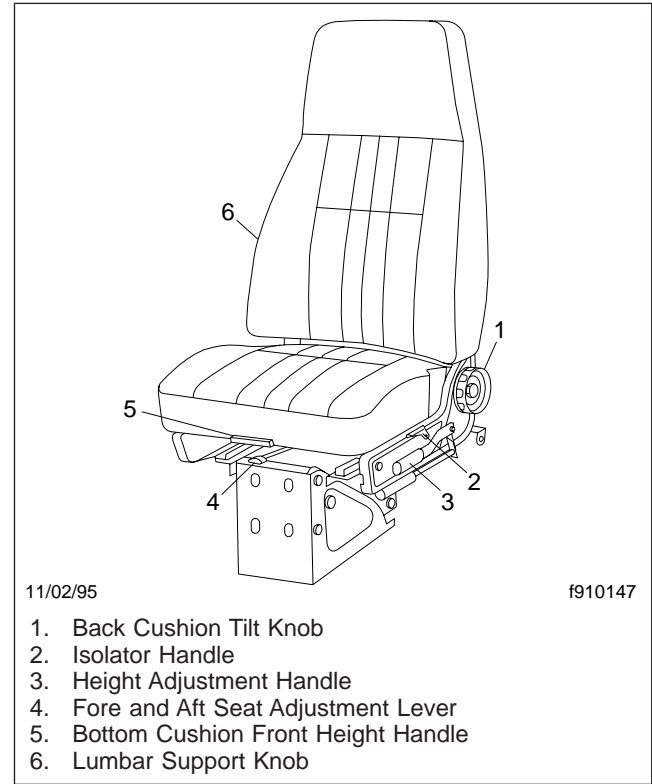

**Fig. 2.7, National Easy-Aire Seat**

# Vehicle Access and Features

## Bottom Cushion Front Height

To adjust the height of the front of the bottom cushion, lift the handle and pull forward or push back to the desired setting.

## Lumbar Support

Turn the knob for precise fit.

## Isolator

Also called a Chugger-Snubber™, the optional isolator is locked out by moving the handle down.

## Bostrom Air-910 Seat (Fig. 2.8)

### Lumbar Support Adjustment

Move the lever forward to increase lumbar support.  
Move the lever rearward to decrease lumbar support.

### Back Cushion Tilt

Hold the lever rearward and lean forward or rearward to the desired position, then release the lever.

### Height Adjustment

Push the knob in to inflate the suspension and raise the seat height. Pull the knob out to deflate the suspension and lower the seat.

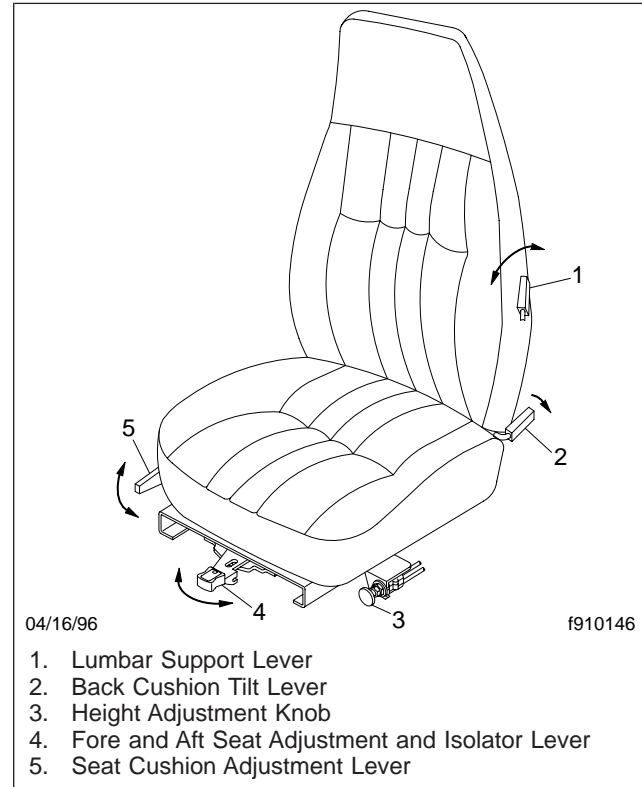

Fig. 2.8, Bostrom Air-910 Seat

## Fore and Aft Seat Adjustment

Move the lever to the left and slide the seat forward or rearward to the desired position. The slide range is six inches.

## Isolator

Isolation is provided when the lever is in the center position. Move the lever to the right to lock out isolation.

## Seat Cushion Adjustment

Move the lever downward to decrease or upward to increase seat cushion tilt. There are five adjustment positions available.

## Bostrom Talladega 900 Seat (Fig. 2.9)

### Back Cushion Tilt

To tilt the back cushion, lean forward slightly to remove pressure from the cushion and hold the lever rearward. Lean backward slowly to the desired position and release the lever to lock the cushion in place.

### Height Adjustment

To raise the seat, push the top portion of the switch. To lower the seat, push the lower portion of the switch.

### Fore and Aft Seat Adjustment

Hold the lever to the left and slide the seat forward or backward to the desired position.

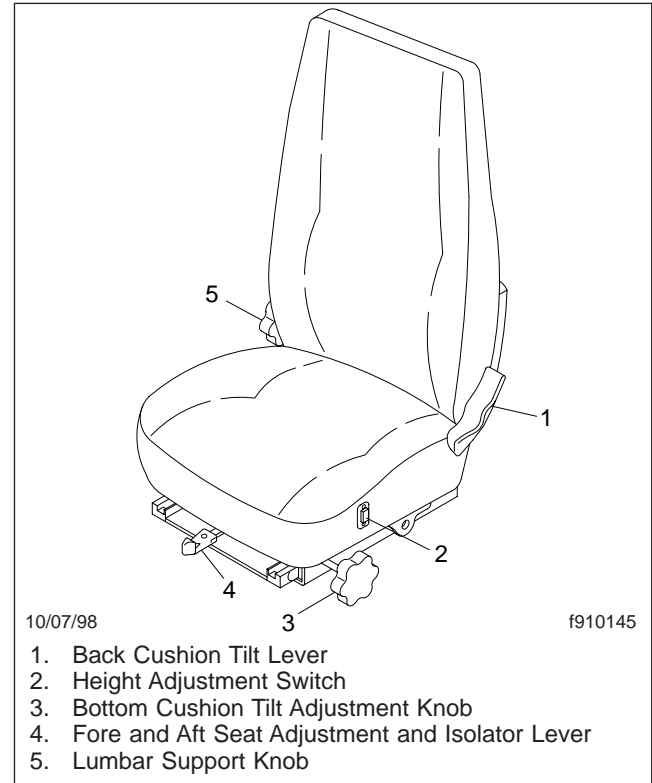

**Fig. 2.9, Bostrom Talladega 900 Seat**

# Vehicle Access and Features

## Isolator

To engage the isolator, put the lever in the center position. Lock out the isolator by moving the lever to the right.

## Bottom Cushion Tilt Adjustment

Rotate the knob to increase or decrease bottom cushion tilt.

## Lumbar Support

Turn the knob for precise fit.

## Dura-Form Seats (Fig. 2.10)

NOTE: Some of the following controls are not available, or are optional, on some Dura-Form seats.

## Back Cushion Tilt

To tilt the back cushion through a range of 10 degrees, push down on the handle. Move the back cushion to the desired position and release the lever.

## Height Adjustment

Push in the knob to inflate the suspension and raise the seat height. Pull out on the knob to deflate the suspension and lower the seat height.

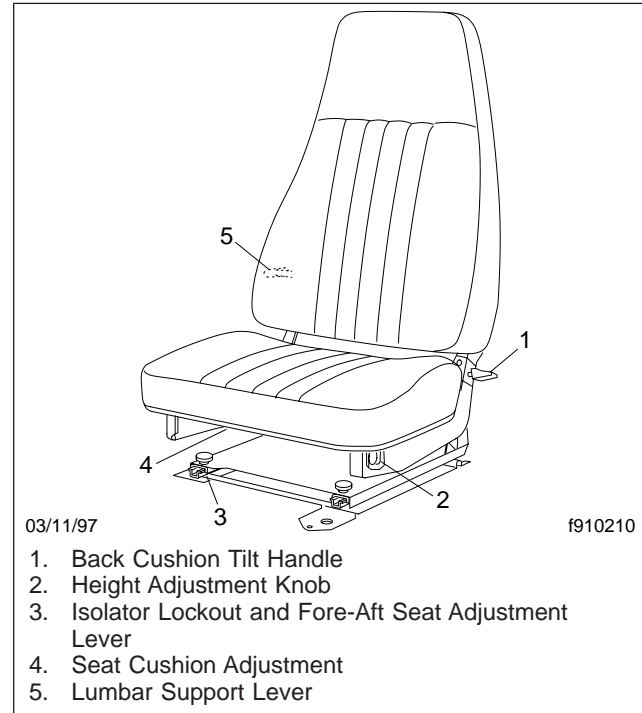

**Fig. 2.10, Dura-Form Seat**

## **Isolator Lockout and Fore-Aft Seat Adjustment**

Move the lever to the left to adjust the seat to the desired fore-aft position. Move the lever to the center position to lock out the isolator feature. Move the lever to the right to engage the isolator.

## **Seat Cushion Adjustment**

To put the seat cushion in the upper position, lift upward on the front of the cushion, then push rearward. To put the seat cushion in the lower position, pull forward and then push downward.

## **Lumbar Support**

Rotate the lever on the right side of the back cushion to any of the three positions as desired.

## **Findlay Bench Seat**

### **Fore-Aft Seat Adjustment**

Move the control lever at the front of the seat to the left to release the locking mechanism, then exert slight body pressure to move the seat forward or rearward, as desired.

Release the lever to lock the seat in place. Push the seat back and forth to ensure that it is locked in place.

## **Seat Belts and Tether Belts**

### **General Information**

Seat belt assemblies are designed to secure persons in the vehicle to help lessen the chance of injury or the amount of injury resulting from accidents or sudden stops. For this reason, Freightliner LLC urges that the driver and all passengers, regardless of age or physical condition, use seat belts when riding in the vehicle.

Seat belt assemblies in the vehicle meet Federal Motor Vehicle Safety Standard 209, "Type 1," and "Type 2" requirements. They are recommended for all persons weighing over 50 pounds (23 kg).

A child restraint system should also be provided for each child weighing 50 pounds (23 kg) or less. It should meet the requirements of Federal Motor Vehicle Safety Standard 213, "Child Restraint Systems." When providing such a restraint system, carefully read and follow all instructions pertaining to installation and usage for the child. Make certain the child remains in the restraint system at all times when the vehicle is in motion.

In addition to seat belt assemblies, tether belts are installed on suspension-type seats. Tether belts help secure the seat to the floor and are intended to restrain the seat and seat belt in case of an accident or sudden stop.

# Vehicle Access and Features

**IMPORTANT:** Seat belts have a finite life which may be much shorter than the life of the vehicle. Regular inspections and replacement as needed are the only assurance of adequate seat belt security over the life of the vehicle.

## Seat Belt Operation

### Three-Point Seat Belt with Komfort Latch

#### **WARNING**

**Wear three-point seat belts only as described below. In case of an accident or sudden stop, injuries could result from misuse. Three-point seat belts are designed to be worn by one person at a time.**

1. Before driving the vehicle, slowly pull the link end of the three-point seat belt out of the retractor and pull it across your lap (from outboard to inboard) far enough to engage the buckle. If the retractor locks too soon, allow the belt to retract slightly, then slowly pull it out again.
2. Fasten the three-point seat belt by pushing the link into the buckle until it latches. See [Fig. 2.11](#). Give the belt a tug at the buckle. If the buckle unlatches,

repeat this step. If the problem continues, replace the three-point seat belt.

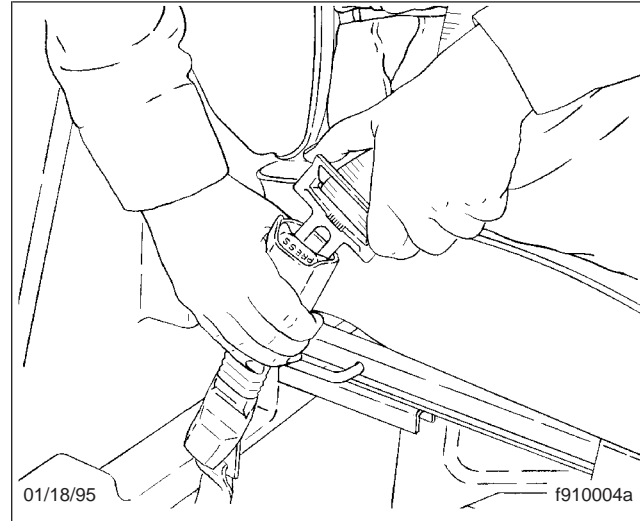

**Fig. 2.11, Fastening the Three-Point Seat Belt**

3. Position the shoulder strap diagonally across your chest. If desired, engage the Komfort Latch as follows:

Pull on the shoulder strap to lessen the pressure of the strap on your shoulder and chest. Allow no more than one inch (2.5 cm) of slack between your

# Vehicle Access and Features

chest and the shoulder harness. More slack can significantly reduce the seat belt's effectiveness in an accident or a sudden stop. While holding the belt slack, press the Komfort Latch lever up, clamping the belt's webbing. See [Fig. 2.12](#) and [Fig. 2.13](#).

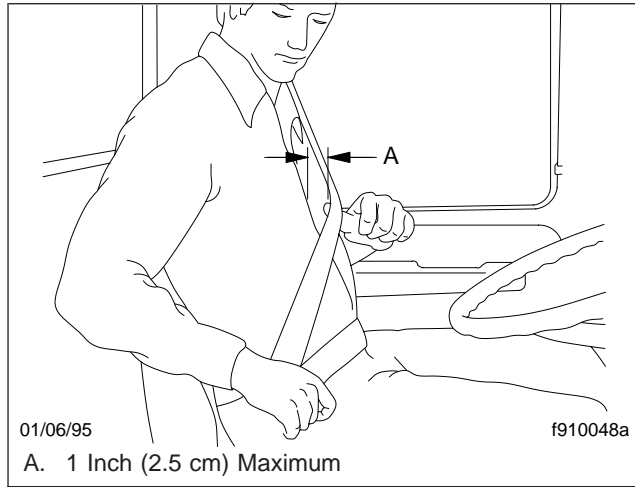

**Fig. 2.12, Adjusting Shoulder Harness Clearance**

4. To unbuckle the three-point seat belt, push the button on the buckle. See [Fig. 2.14](#). If the Komfort Latch was used, release it by giving the shoulder belt a quick tug. If you lean forward against the

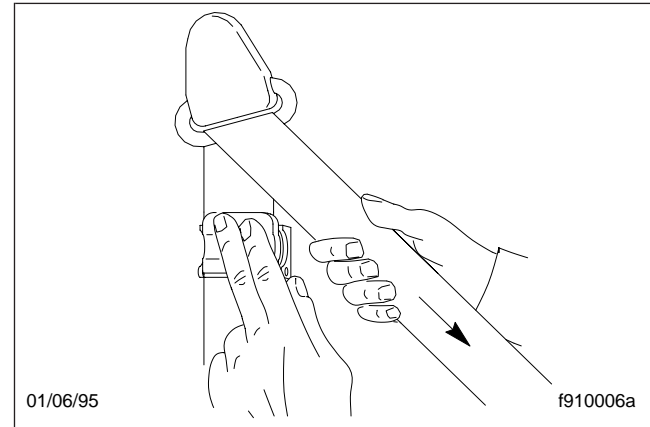

**Fig. 2.13, Locking Komfort Latch**

shoulder belt, the Komfort Latch will automatically release, and will need to be reset.

**NOTE:** The Komfort Latch does not have to be released in an emergency situation. The Komfort Latch will release by itself under rough road or other abnormal conditions. Make sure the three-point seat belt is completely retracted when it is not in use.

# Vehicle Access and Features

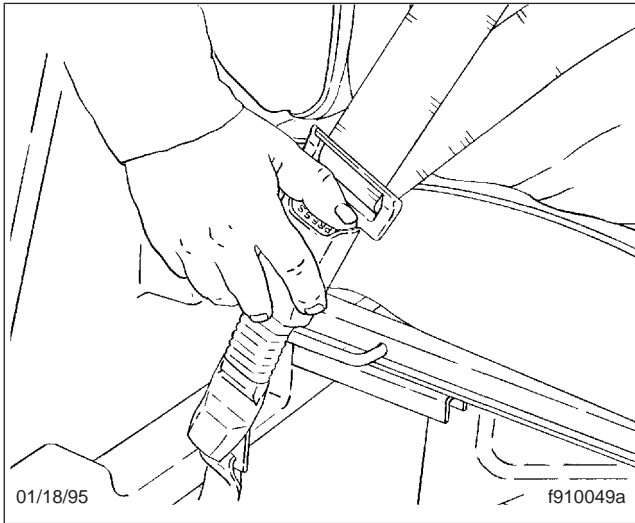

Fig. 2.14, Releasing the Three-Point Seat Belt

## Lap Belt



Wear lap belts only as described below. In case of an accident or sudden stop, injuries could result from misuse. Lap belts are designed to be worn by one person at a time.

1. Slowly pull the link end of the lap belt across your lap. If it is necessary to lengthen the belt, tip the link end downward and pull the link until it connects with the buckle.
2. Fasten the lap belt by pushing the link into the buckle until they latch. See Fig. 2.15. Make sure the belt is not twisted. Check the engagement by trying to pull the link out of the buckle. If they come apart, repeat this step. If the problem continues, replace the belt.

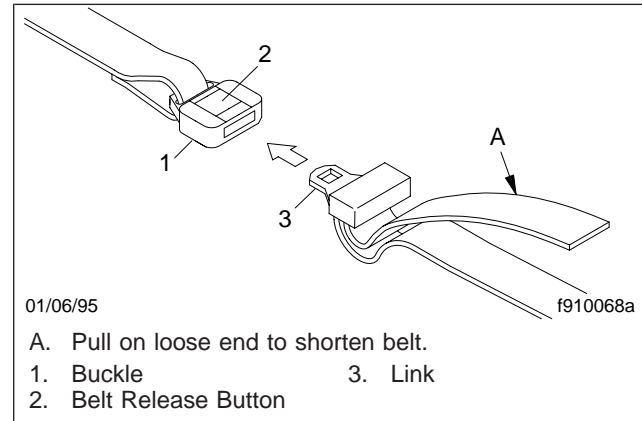

Fig. 2.15, Belt Adjustment



# Vehicle Access and Features

NOTE: The belt can be shortened after it is connected by pulling on the loose end until the belt is snug, but comfortable.

3. To release the belt, push the release button on the buckle and pull the link from the buckle.

## Sleeper Compartment Bunk Restraints

### General Information

On vehicles equipped with a sleeper compartment, bunk restraints should be used whenever the sleeper compartment is occupied and the vehicle is moving. Restraints are designed to lessen the chance of injury or the amount of injury resulting from accidents or sudden stops. For this reason, Freightliner LLC urges the use of bunk restraints when the sleeper compartment is occupied in a moving vehicle.



**Always use the bunk restraints when the sleeper compartment is occupied in a moving vehicle. Failure to do so increases the chance of injury or the degree of injury from accidents or sudden stops to all occupants in the vehicle.**

### Bunk Restraint Adjustment

1. Make sure the belt is attached to the bunk support and sleeper wall.
2. To lengthen the belt, tip the link end downward and pull the link until it connects with the buckle.
3. After the belt is connected, shorten it by pulling on the loose end until the belt is snug, but comfortable. Be sure the belts are not twisted. See [Fig. 2.15](#).

### Bunk Restraint Operation ([Fig. 2.16](#))



**Do not use the upper bunk while the vehicle is in motion unless a bunk restraint is installed and used. Not using the bunk restraint increases the chance of injury or the degree of injury from accidents or sudden stops to all occupants in the vehicle.**

1. Starting at the foot of the bunk, pull up the link end of the belt far enough to engage the buckle.
2. Fasten the belt by pushing the link end into the buckle until they latch. Make sure that the belt is not twisted. Check the engagement by trying to pull the link out of the buckle. If they come apart, repeat this step. If the problem continues, replace the belt.

# Vehicle Access and Features

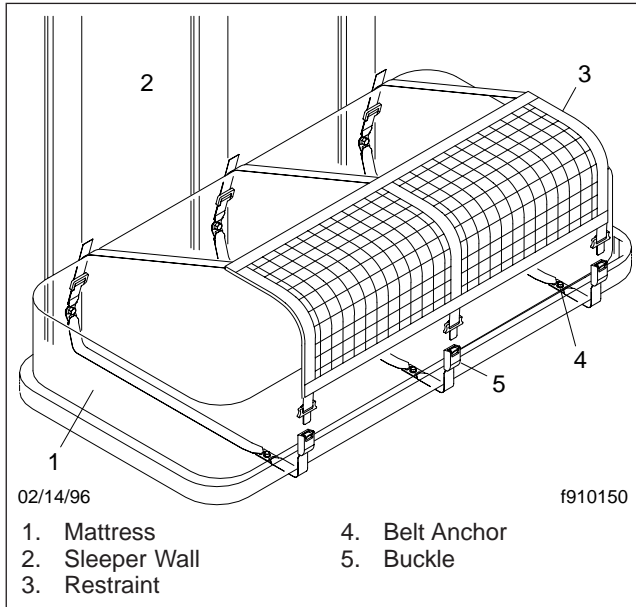

**Fig. 2.16, Bunk Restraint**

Repeat steps 1 and 2 for the other two belts located in the middle and upper portion of the bunk to lock the restraint in place.

3. To release the bunk restraint, push the release button on the buckle at the head of the bunk and pull the link from the buckle.

Repeat this step for the other two buckles to completely release the bunk restraint.

## Bunk Mattress

To prevent damage to the bunk mattress and to ensure even wear, it is recommended that the mattress be turned over on a monthly basis.

## Under Bunk Storage

To achieve maximum use of the under bunk storage, move the driver and passenger seats to the most forward position on the slide tracks. When you are done accessing the storage compartment, adjust the seats as necessary before operating the vehicle.

## Fuse/Relay/Circuit Breaker Identification

NOTE: The fuse/relay/circuit breaker panel ([Fig. 2.17](#)) is located behind an access panel below the right-hand corner (passenger's side) of the dash. To gain access to the panel, remove the two fasteners that attach the cover to the cab floor and

frontwall. Depending on vehicle options, fuse/relay/circuit breaker locations may vary from those shown. Refer to **Fig. 2.17** or **Table 2.1** for the Fuse/Relay/Circuit Breaker Identification information.

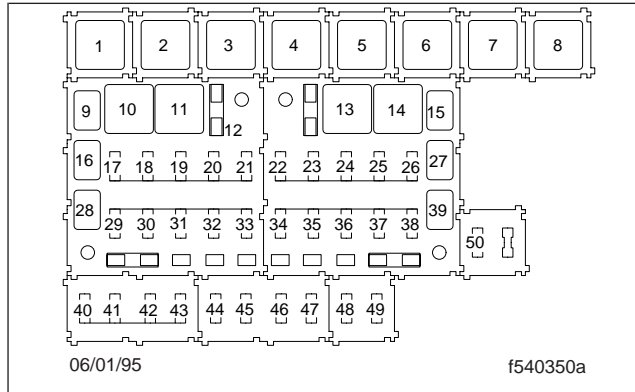

**Fig. 2.17, Fuse/Relay/Circuit Breaker Identification**

NOTE: For specific fuse/relay/circuit breaker information for the Dodge Magnum V8 gasoline engine, refer to **Fig. 2.18**.

## Hood Tilting

A grab handle at the front of the hood provides a handhold for hood tilting. Stop cables prevent the hood from overtravel. In the operating position, the hood is secured to the lower cab half-fenders by a hold-down latch on each side of the hood.

Fuse/Relay/Circuit Breaker Identification			
Pos. No.	Description	Part Number	Rating
1	Hazard Warning Flasher		
	Thermal	681 822 00 21	—
	Solid State	680 822 00 21	15A
2	Trailer Marker Light Relay	23-11276-011	—
3	Trailer Taillight Relay	23-11276-011	—
4	2-Speed Axle Relay	23-11276-011	—
5	Fuel/Water Separator Heater Relay	23-11276-011	—
6	Engine Shutdown Warning Relay	23-11276-011	—
7	Engine Shutdown Warning Relay	23-11276-011	—
8	Fog Light Relay	23-11276-011	—
9	AC Compressor and Clutch Relay	680 545 00 05	—

# Vehicle Access and Features

Fuse/Relay/Circuit Breaker Identification			
Pos. No.	Description	Part Number	Rating
10	Brake Light Relay	23-11276-011	—
11	Blower Motor Relay	23-11276-011	—
12	Heater Blower Motor	680 545 02 34 680 545 23 66	—
13	Heater and AC Switch Relay	23-11276-011	—
14	Trailer and Marker Light Relay	23-11276-011	—
15	Panel Light Relay	680 545 00 05	—
16	Parking Brake Relay	680 545 00 05	—
17	Windshield Wiper and Washer	680 545 16 66	15A C.B.
18	Backup Light Switch and Radio	LF 257 010 680 545 19 66	10A Fuse 10A C.B.
19	Low Coolant and Heater Mirror	LF 257 015 680 545 20 66	15A Fuse 15A C.B.
20	Heater and AC Switch	LF 257 015 680 545 20 66	15A Fuse 15A C.B.
21	Ether Start	LF 257 010 680 545 19 66	10A Fuse 10A C.B.
22	Taillight	LF 257 015 680 545 20 66	15A Fuse 15A C.B.

Fuse/Relay/Circuit Breaker Identification			
Pos. No.	Description	Part Number	Rating
23	Cigarette Lighter	LF 257 015 680 545 20 66	15A Fuse 15A C.B.
24	AC Compressor	LF 257 010 680 545 19 66	10A Fuse 10A C.B.
25	Turn Signal Flasher	LF 257 020	20A Fuse
26	Headlight, Right	LF 257 015 680 545 16 66	15A Fuse 15A C.B.
27	Headlight Relay, Right	680 545 00 05	—
28	Auxiliary Feed Relay	680 545 00 05	—
29	Fuel Solenoid	LF 257 010 680 545 19 66	10A Fuse 10A C.B.
30	Flame Start and Fan Clutch	LF 257 025 680 545 22 66	25A Fuse 25A C.B.
31	Instruments and Gauges	LF 257 010 680 545 15 66	10A Fuse 10A C.B.
32	Hydraulic Brakes	231284 000005	5A Fuse
33	Relay Coil Feeds	231284 000005	5A Fuse
34	Panel Lights	LF 257 015 680 545 20 66	15A Fuse 15A C.B.
35	Stoplight Switch	LF 257 015 680 545 16 66	15A Fuse 15A C.B.
36	Horn and Dome Light	LF 257 015 680 545 20 66	15A Fuse 15A C.B.

# Vehicle Access and Features

Fuse/Relay/Circuit Breaker Identification			
Pos. No.	Description	Part Number	Rating
37	Accessory Feed	LF 257 010 680 545 19 66	10A Fuse 10A C.B.
38	Headlight, Left	LF 257 015 680 545 16 66	15A Fuse 15A C.B.
39	Headlight Relay, Left	680 545 00 05	—
40	Flame Start	LF 257 025 680 545 22 66	25A Fuse 25A C.B.
41	Utility Light	LF 257 020 680 545 21 66	20A Fuse 20A C.B.
42	Road Light Switch	LF 257 020 680 545 21 66	20A Fuse 20A C.B.
43	Daytime Running Lights	LF 257 020 680 545 17 66	20A Fuse 20A C.B.
44	2-Speed Axle Shift	LF 257 020 680 545 21 66	20A Fuse 20A C.B.
45	Auxiliary Trailer Feed	LF 257 015 680 545 20 66	15A Fuse 15A C.B.
46	Trailer Marker Lights	LF 257 020 680 545 21 66	20A Fuse 20A C.B.
47	Trailer, Marker, and Taillights	LF 257 020 680 545 21 66	20A Fuse 20A C.B.
48	Fuel and Water Separator Heater	LF 257 020 680 545 21 66	20A Fuse 20A C.B.

Fuse/Relay/Circuit Breaker Identification			
Pos. No.	Description	Part Number	Rating
49	Fuel and Water Separator	231284 000005	5A Fuse
50	Air Dryer	LF 257 015 680 545 20 66	15A Fuse 15A C.B.

Table 2.1, Fuse/Relay/Circuit Breaker Identification

## To Tilt the Hood

1. Apply the parking brakes.
2. Release both hood hold-down latches by pulling the ends up (**Fig. 2.19**).
3. Using the bumper step and grab handle (**Fig. 2.20**), slowly tilt the hood until the stop cables support it.



**Do not let the hood free fall to the open position. To do so could cause damage to the hood, or the stop cables.**

# Vehicle Access and Features

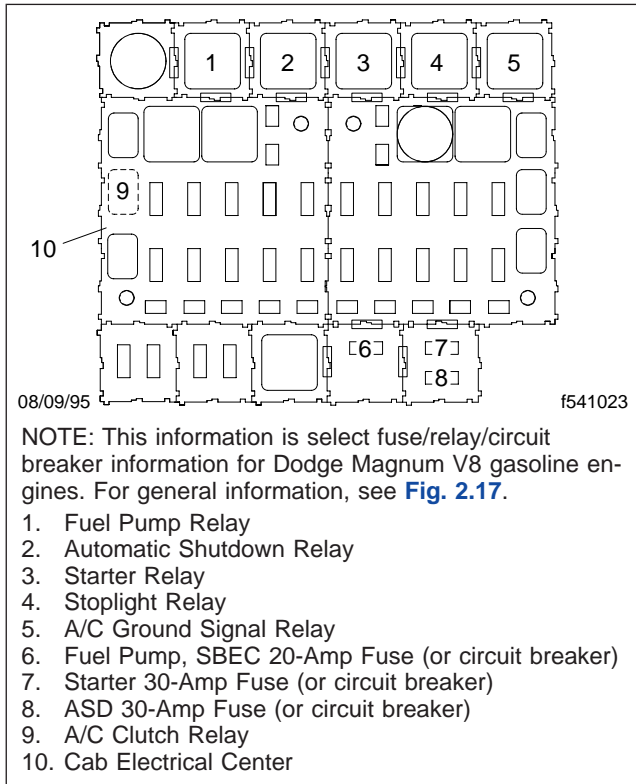

**Fig. 2.18, Fuse/Relay/Circuit Breaker Identification for the Dodge Magnum V8 Gasoline Engine**

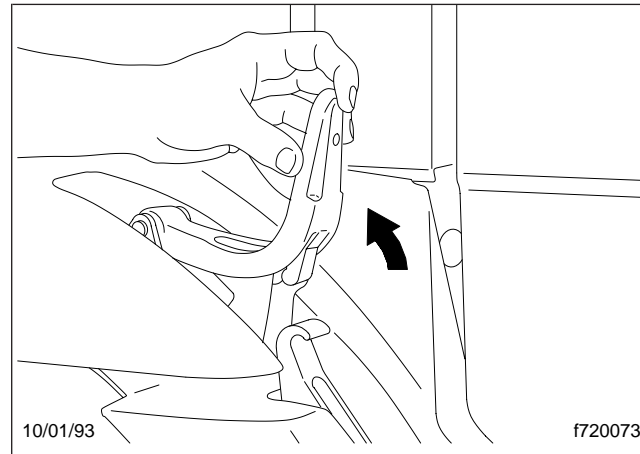
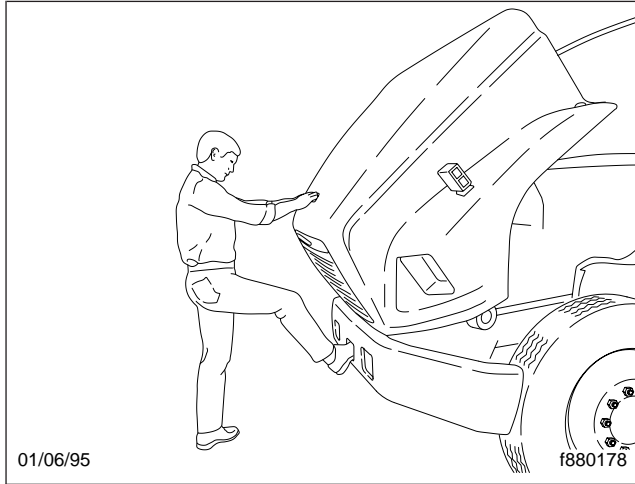

**Fig. 2.19, Unlatch the Hood**

## To Return the Hood

1. Grasp the grab handle, and lift the hood to the 45-degree position.
2. As the hood goes over center, use the bumper step and grab handle to control the rate of descent to the operating position.
3. Make sure the hood is flush with the cowl, then secure the hood by engaging both hood hold-down latches.

# Vehicle Access and Features



**Fig. 2.20, Hood Tilting**

**IMPORTANT:** Make sure that both hold-down latches are fully engaged before operating the vehicle.

## Back-of-Cab Grab Handles, Steps, and Deck Plate

When climbing onto the frame rails or deck plate, use the grab handle and steps. Always maintain three-point contact with the back-of-cab access system.

A grab handle is mounted on the cab. When an optional deck plate is included, it is mounted across the top of the frame rails.

## Driver Controls and Instruments

Instruments and Controls Identification .....	3.1
Controls .....	3.1
Instrumentation Control Unit, Level I .....	3.19
Warning and Indicator Lights, Right-Hand-Drive and Mechanical Engine Vehicles .....	3.23
Collision Warning System (CWS), Eaton VORAD EVT-300, Optional .....	3.31
Instruments .....	3.39
Heater and Air Conditioner .....	3.44



# Driver Controls and Instruments

---

## Instruments and Controls Identification

**Figure 3.1** represents a typical Freightliner dash equipped with all of the standard and many of the optional instruments and controls for left-hand-drive (LH DR) vehicles equipped with electronic engines. **Figure 3.2** shows the Level I ICU gauge portion of the dash for those vehicles.

**Figure 3.3** represents the gauge portion of a typical right-hand-drive (RH DR) vehicle, or a vehicle with a mechanical engine.

NOTE: Right-hand-drive vehicles are built with the instrument control panel on the right side of the dash. The instrument configurations and control instructions in this manual are for left-hand-drive vehicles. In addition, dash gauges in right-hand-drive vehicles feature metric units of measure.

## Controls

### Ignition Switch and Key

The ignition switch can be turned to four positions: off, accessory, on, and start. See **Fig. 3.4**. The ignition switch key also locks and unlocks the cab doors.

The key can be inserted and removed only from the off position (key slot is vertical). The headlights (low beam only), brake lights, road lights, dome lights, clearance lights, turn signals, hazard warning lights, parking lights, and the cigarette lighter operate with the ignition switch off, regardless of whether or not the key is inserted.

In the accessory position (key is turned counterclockwise), the wipers, heated mirrors, backup lamps, radio, ether start system, and all electric gauges operate.

Turn the key fully clockwise to the start position only when starting the engine. When the engine starts, release the key. When released, the key will move to the on position.

In the on position (key turned 45 degrees clockwise), all electrical systems are operable. Warning lights and buzzer for low air pressure and low oil pressure operate until the engine is started and minimum pressures are built up.

### Mirror Heat Switch, Optional

One or both outside door mirrors can be heated to keep them defrosted. See **Fig. 3.5**.

### Panel Light Dimmer Switch

The panel lights are turned on by the headlight switch. The panel light rheostat controls the brightness of the instrument panel lights. Slide the control lever up to

# Driver Controls and Instruments

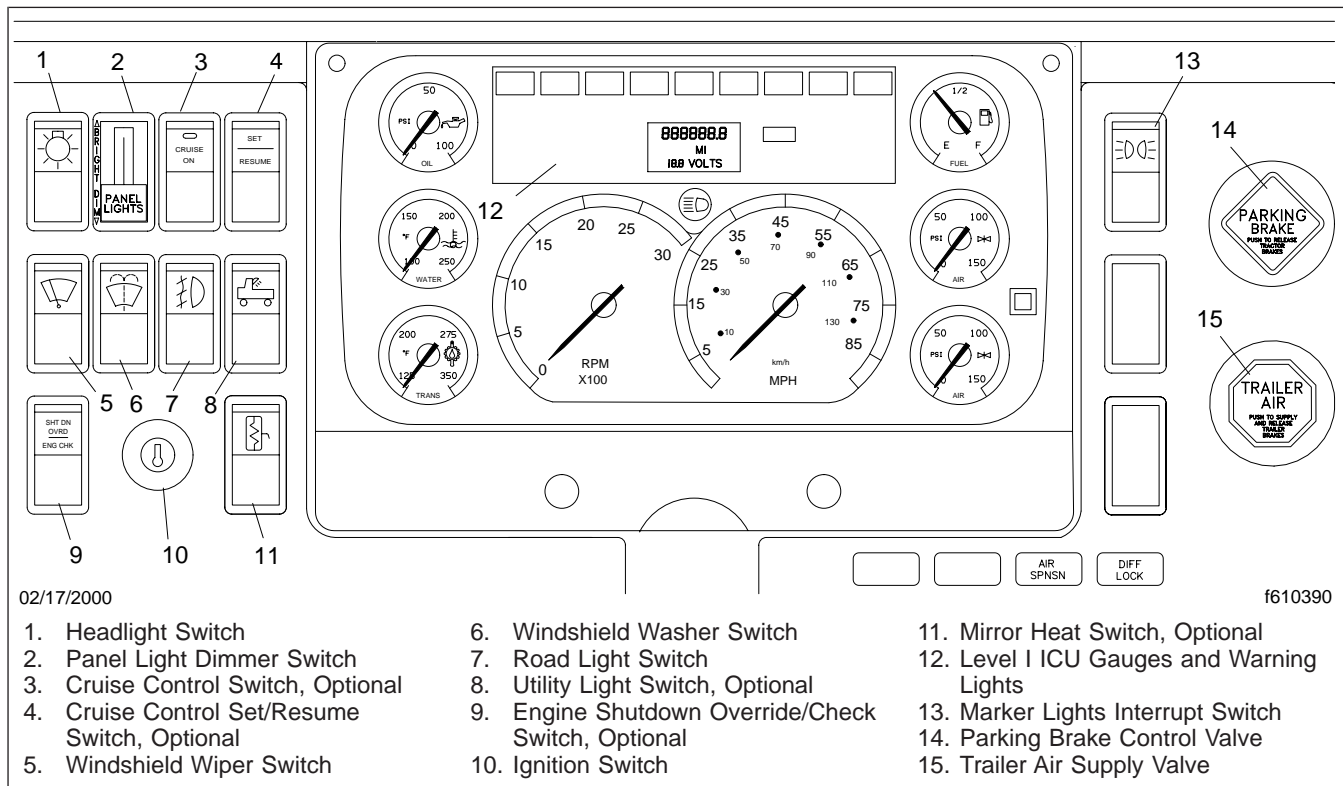

**Fig. 3.1, Instrument and Control Panel Layout (typical, left-hand-drive vehicles)**

# Driver Controls and Instruments

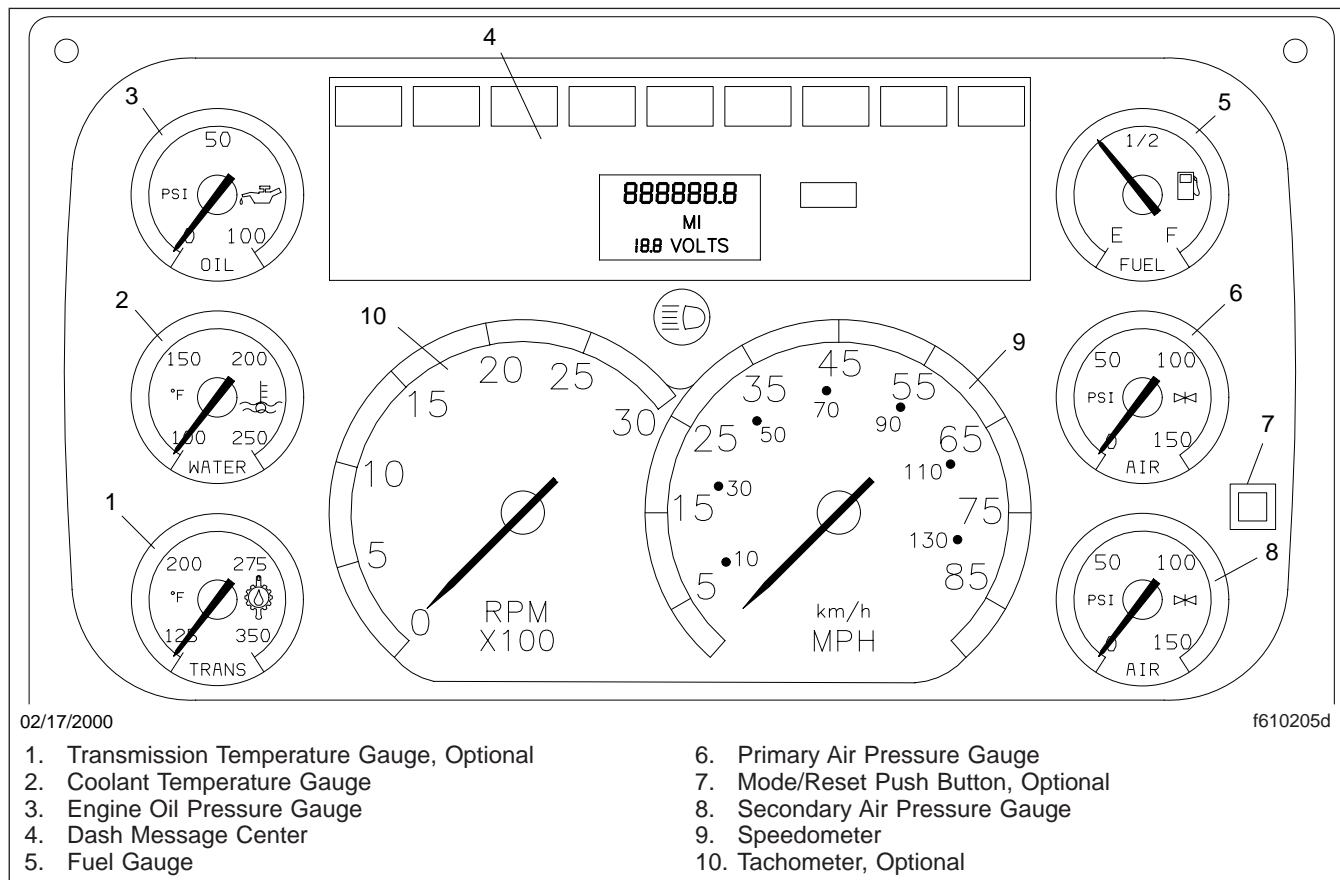
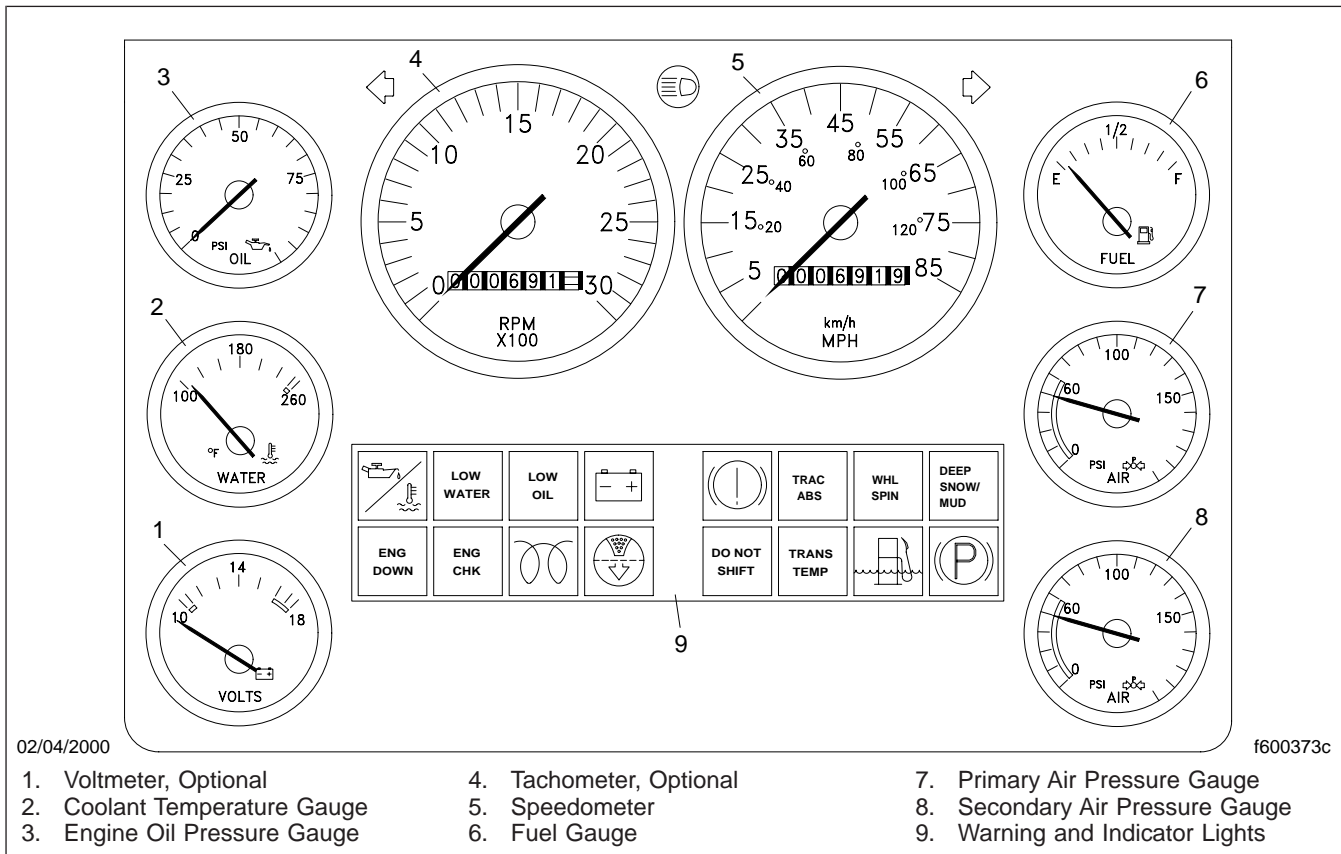

Fig. 3.2, Level I ICU Gauge Layout (typical)

# Driver Controls and Instruments



**Fig. 3.3, Gauges and Warning Lights (right-hand-drive and mechanical engine vehicles)**

# Driver Controls and Instruments

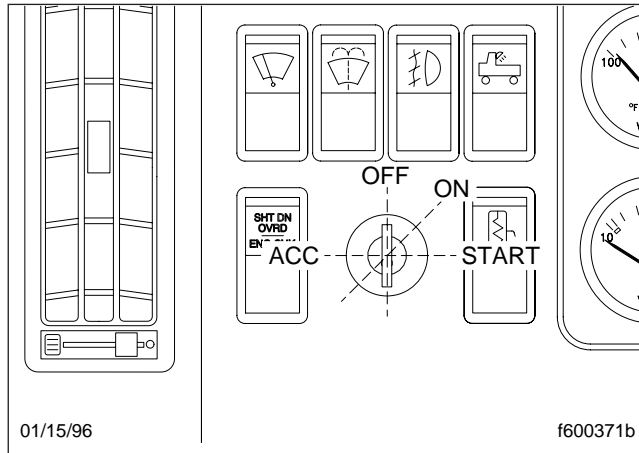

**Fig. 3.4, Ignition (switch locations typical)**

brighten the lights and down to dim them. Move the control lever all the way down to turn them off. See [Fig. 3.6](#).

## Road Light Switch, Optional

The road light switch operates the road lights which are recessed into the front bumper. See [Fig. 3.7](#).

For vehicles built to operate in the United States, the low-beam headlights must be turned on before the road lights can be turned on. The road lights won't go on if

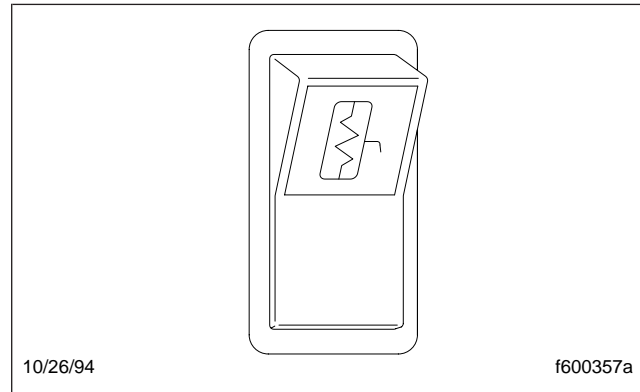

**Fig. 3.5, Mirror Heat Switch, Optional**

the high-beam headlights are already on, and switching from low beams to high beams will switch off the road lights.

For vehicles built to operate in Canada, the taillights and clearance lights must be on before the road lights can be turned on. The road light switch will not turn on the road lights unless the headlight switch is all the way up (headlights, taillights, clearance lights, marker lights, and panel lights on) or down (taillights, clearance lights, marker lights, and panel lights on).

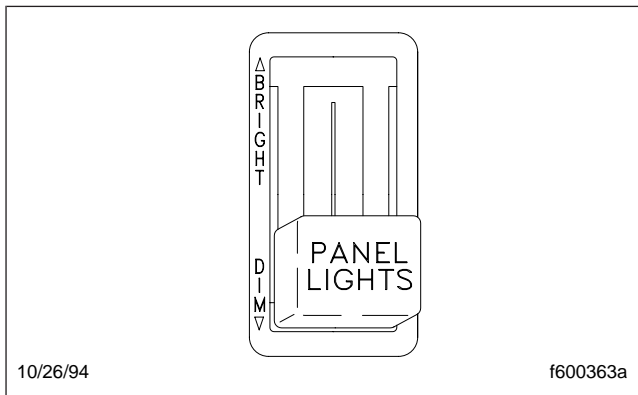

**Fig. 3.6, Panel Light Control Lever**

## Utility Light Switch, Optional

The utility lights, mounted in the back of the cab, are operated by the utility light switch. See [Fig. 3.8](#).

## Headlight Switch and Daytime Running Lights

See [Fig. 3.9](#). The up position turns on the headlights, marker lights, taillights, clearance lights, and panel lights. The middle position turns on the taillights, marker lights, clearance lights, and panel lights. The down position turns all of these lights off.

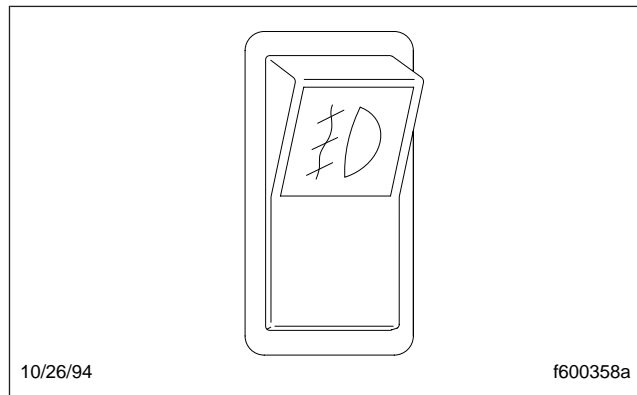
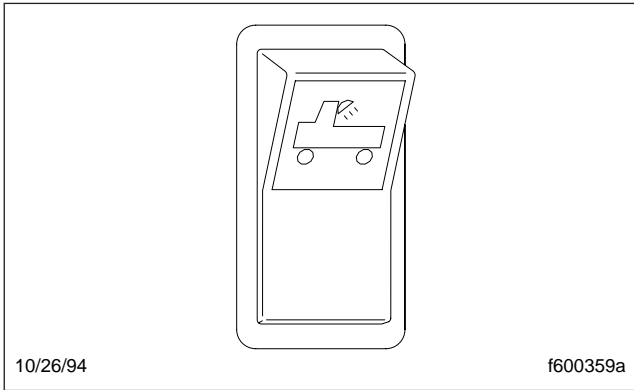

**Fig. 3.7, Road Light Switch, Optional**

The high-beam headlights are activated by pulling up on the turn signal lever. When the headlights are on high beam, a blue light illuminates between the speedometer and tachometer. The ignition switch must be on for the high beams to operate.

Daytime running lights (DRL) are required in Canada, and optional in the United States. On vehicles equipped with DRL, turning on the ignition switch and releasing the parking brakes automatically activates the headlight low beams at 86 percent of full voltage. Turning on the regular headlights will override the DRL. While the vehicle is being operated, either the headlights or the DRL must be activated. The DRL continue to operate until

# Driver Controls and Instruments

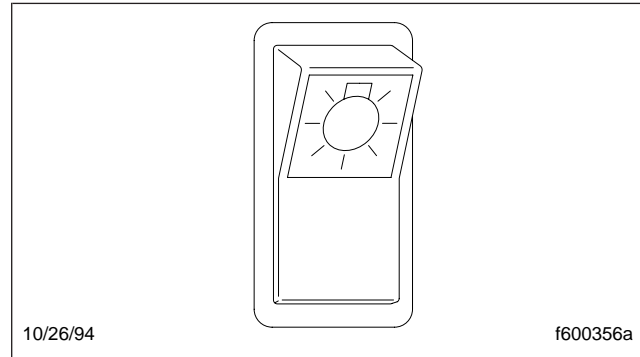

**Fig. 3.8, Utility Light Switch, Optional**

the parking brakes are applied or the ignition switch is turned off.

## Windshield Wipers

There are two different windshield wiper installations, one with and one without the intermittent function. On vehicles without intermittent wipers, the windshield wipers and washers are operated by separate rocker switches. To operate the wipers, move the rocker switch to one of two speed settings: low or high. See [Fig. 3.10](#).



**Fig. 3.9, Headlight Switch**

On vehicles with intermittent wipers, the wiper and washer controls consist of either a rocker switch and a slider switch, or a double-paddle switch.

On vehicles with intermittent wipers with rocker switch and slider switch controls, the continuous low and high wiper speeds are engaged with the rocker switch. The intermittent wipers are turned on by moving the slider switch up to select the desired delay interval between 2 and 10 seconds. An indicator light illuminates when the slider switch is engaged. Intermittent wiper action is overridden when the rocker switch is set to either continuous position. See [Fig. 3.11](#).

On vehicles with intermittent wipers with a double-paddle switch, the top paddle, when pushed in, turns

# Driver Controls and Instruments

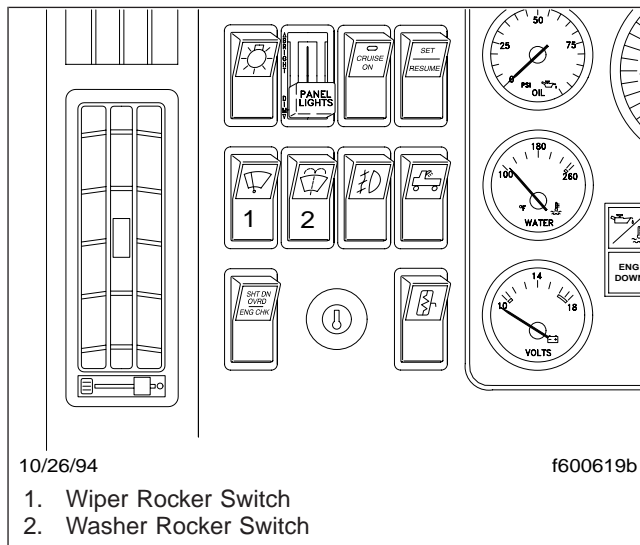

**Fig. 3.10, Wiper and Washer Switch Locations (typical), Without Intermittent Wiper Function**

the wipers on or off. When it is pushed up, the top paddle switches the wipers to high speed; when it is pushed down, the wipers operate at low speed. See [Fig. 3.12](#).

Pushing the bottom paddle up or down controls the intermittent wipers. When the bottom paddle is pushed up, the wipers operate in fast delay. When the bottom

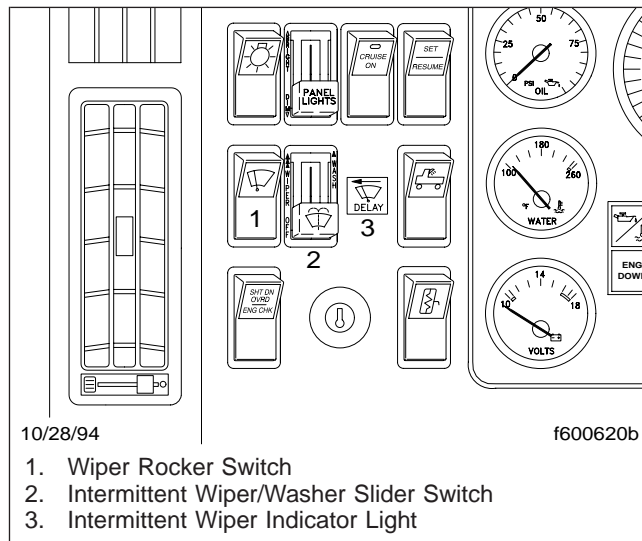
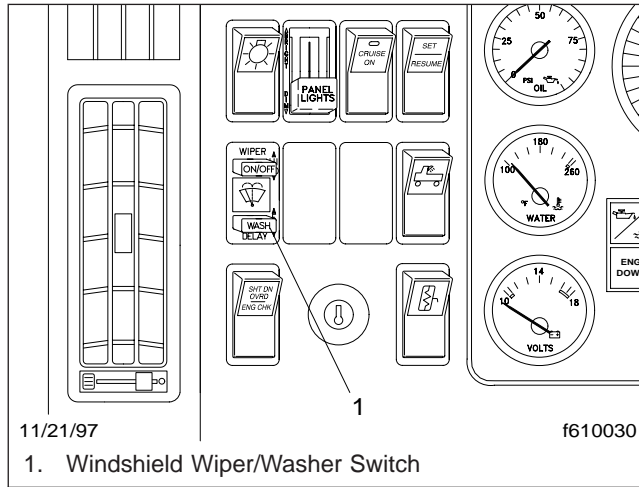

**Fig. 3.11, Rocker Switch and Slider Switch Locations, With Intermittent Wiper Function**

paddle is pushed down, the wipers operate in slow delay. With the wipers in delay mode (fast or slow), push the bottom paddle up to shorten the delay period, or push the paddle down to lengthen it.



# Driver Controls and Instruments



**Fig. 3.12, Double-Paddle Switch Location, With Intermittent Wiper Function**

## CAUTION

**Do not move the wiper arms manually. Wiper motor damage will occur if the arms are moved.**

## Windshield Washer

On vehicles without intermittent wipers, depress the washer rocker switch to operate the washer. Washer

fluid will be sprayed onto the windshield as long as the switch is depressed. See [Fig. 3.10](#).

On vehicles with intermittent wipers with rocker switch and slider switch controls, push the slider switch all the way up to operate the windshield washer. See [Fig. 3.11](#).

On vehicles with intermittent wipers with a double-paddle switch, push in the bottom paddle to turn the washers on. When pushed in for less than 1/2-second, the wipers will perform a single, low speed dry wipe (mist function). When pushed and held in, the wash cycle begins and continues for three wiper blade cycles, or until the paddle is released. See [Fig. 3.12](#).

## Interrupt Switch, Optional

A spring-loaded interrupt switch operates the marker lights and taillights. With the vehicle lights on, depress and release the interrupt switch to briefly turn off the marker lights and taillights. See [Fig. 3.13](#).

## Caterpillar Electronic Engine Operator Control

Caterpillar electronic engines use a computer (electronic control module) to automatically control engine timing and fuel injection. The electronic features of these engines include an electronic governor, fuel-to-air ratio control, programmable engine ratings, injection

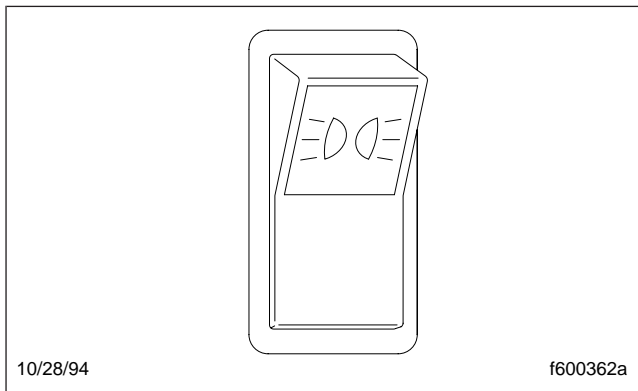

**Fig. 3.13, Interrupt Switch, Optional**

timing control, fault analysis and recording, and a data link used for programming the electronic control module and troubleshooting the system.

All Caterpillar electronic engines have a check engine indicator in the lightbar located below the speedometer and tachometer. This indicator light illuminates or flashes if the engine oil pressure is low, the coolant temperature is high, the intake manifold air temperature is high, the coolant is low (optional), or whenever there is a problem within the electronic engine system. Some vehicles equipped with Caterpillar electronic engines have an automatic engine shutdown option. This option will shut off fuel to the engine if potentially damaging

conditions are detected. See the Caterpillar electronic engine troubleshooting manual for troubleshooting procedures.

The cruise control and PTO governor options are controlled in two ways:

*The CRUISE ON and SET/RESUME switches on the instrument control panel. See Fig. 3.14. The CRUISE ON switch turns on the cruise control, and the SET/RESUME switch is used to select the cruise speed, or to resume cruise control after slowing down. For PTO operation, the CRUISE ON switch turns on the PTO, and the SET/RESUME switch is used to either select or resume the engine operating speed. The dash-mounted cruise control switches are also used to check the electronic control module (ECM) for system faults when the engine is not running. The SET/RESUME switch is spring-loaded to return to neutral. See Chapter 4 for complete instructions.*

*The optional PAUSE, RESUME, and SET buttons on the transmission shift knob. See Fig. 3.15. The PAUSE button allows the driver to temporarily interrupt cruise control. The RESUME button allows the driver to resume the cruise speed after slowing down. The SET button allows the driver to select the cruise speed. For PTO operation, the PAUSE button temporarily interrupts PTO operation, the RESUME button resumes PTO operation at the previously selected engine speed, and the*

# Driver Controls and Instruments

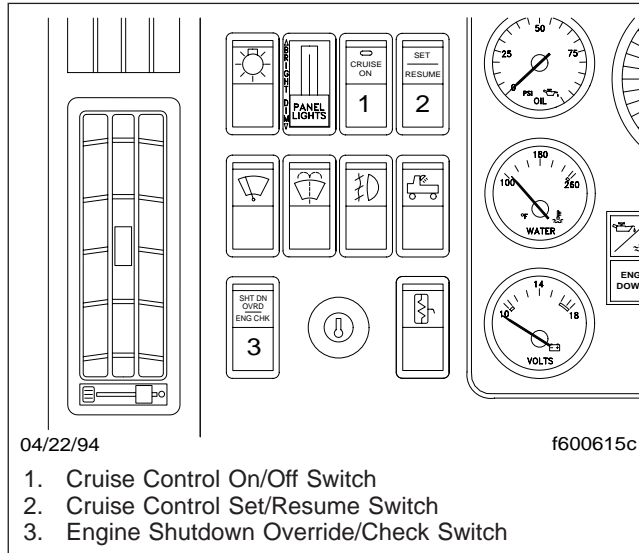

**Fig. 3.14, Cruise Control Switches and Engine Shutdown Override/Check Switch Locations (typical)**

SET button is used to select the engine operating speed. See [Chapter 4](#) for complete instructions.

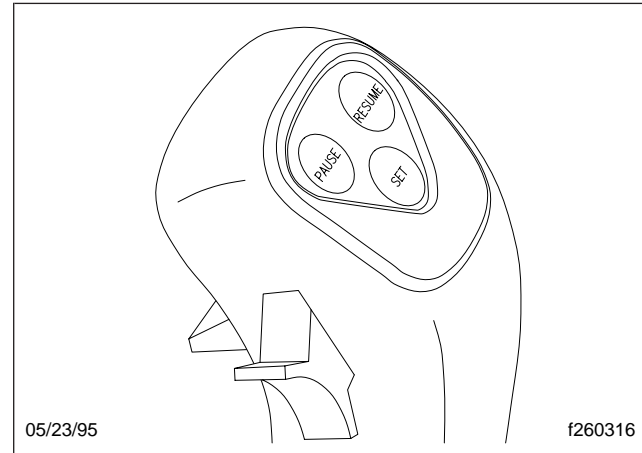

**Fig. 3.15, Cruise Control, Transmission Shift Knob Buttons**

## Cummins Electronic Engine Operator Control

The Cummins CELECT is a fuel control system installed on M11 engines. The CELECT system is controlled by a microprocessor-based computer. This computer controls specific engine and vehicle speed modes of operation to maximize vehicle fuel economy and performance.

Vehicles with CELECT engines have a yellow check engine indicator light and a red stop engine warning

light in the lightbar located below the speedometer and tachometer. With the ignition switch on, both lights come on for about two seconds, then, if there is no problem with the CELECT engine system, the lights will go out. Whenever there is a problem within the electronic engine system, one of the lights will come on and stay on as long as the problem exists.

If the yellow check engine light illuminates while driving some CELECT features will not work, but the vehicle can still be driven. If the red stop engine light illuminates while driving and if the engine will not accelerate, pull off of the road and shut down the engine. In either situation, have the problem repaired as soon as possible.

If the system is programmed to shut down, the engine will shut down 30 seconds after the red engine protection light illuminates. The ignition switch will restart the engine after shutdown. However, if the potentially damaging problem still exists, the engine will operate at the reduced speed or torque level allowed just prior to shutdown.

The cruise control and PTO governor options are controlled in two ways:

*The CRUISE ON and SET/RESUME switches on the instrument control panel.* See [Fig. 3.14](#). The CRUISE ON switch turns on the cruise control, and the SET/RESUME switch is used to select the cruise speed, or to resume cruise control after slowing down. For PTO

operation, the CRUISE ON switch turns on the PTO, and the SET/RESUME switch is used to either select or resume the engine operating speed. The SET/RESUME switch is spring-loaded to return to neutral. See [Chapter 4](#) for complete instructions.

*The optional PAUSE, RESUME, and SET buttons on the transmission shift knob.* See [Fig. 3.15](#). The PAUSE button allows the driver to temporarily interrupt cruise control. The RESUME button allows the driver to resume the cruise speed after slowing down. The SET button allows the driver to select the cruise speed. For PTO operation, the PAUSE button temporarily interrupts PTO operation, the RESUME button resumes PTO operation at the previously selected engine speed, and the SET button is used to select the engine operating speed. See [Chapter 4](#) for complete instructions.

## Detroit Diesel Electronic Engine Control (DDEC) Operator Control

The DDEC system is centered around a computer that is programmed to automatically control engine timing and fuel injection, providing maximum engine performance and fuel economy.

Some DDEC II® systems have an automatic engine shutdown option. This option will shut down the engine if potentially damaging conditions are detected. An override switch (on DDEC II engines, this switch is labelled "Override") is provided for emergency situations. It is

# Driver Controls and Instruments

---

mounted to the left of the ignition switch, and provides the driver with an extra 30 seconds of engine operating time.

Standard DDEC III® systems will shut down the engine if sensors indicate an emergency engine condition such as low coolant level, high coolant temperature, high oil temperature, or low oil pressure. If such a condition occurs, the yellow CHECK ENGINE light in the warning and indicator light module will come on. If the problem gets bad enough to cause possible engine damage, the DDEC III will gradually cut engine power down to 70 percent of original power. At that point, the red engine protection (ENG PROTECT) light will come on, and 30 seconds later, DDEC III will shut down the engine (if programmed).

If DDEC III detects low oil pressure, both the check engine and engine protection lights will come on and the engine will shut down in 30 seconds (if programmed).

**NOTE:** If the vehicle is in a hazardous place when the "Shutdown Engine" light illuminates, the driver must immediately press the "Override/Chk" switch or the engine will shut down in 30 seconds. Pressing the switch will give the driver an additional 30 seconds to move the vehicle. If this is still not enough time, the driver must press the switch again for another 30-second delay before engine shutdown.

Once the engine has shut down, cycle the ignition key off and then on, and press the "Override/Chk" switch to restart the engine.

The cruise control and PTO governor options are controlled in two ways:

*The optional PAUSE, RESUME, and SET buttons on the transmission shift knob. See Fig. 3.15.* The PAUSE button allows the driver to temporarily interrupt cruise control. The RESUME button allows the driver to resume the cruise speed after slowing down. The SET button allows the driver to select the cruise speed. For PTO operation, the PAUSE button temporarily interrupts PTO operation, the RESUME button resumes PTO operation at the previously selected engine speed, and the SET button is used to select the engine operating speed. See [Chapter 4](#) for complete instructions.

## Parking Brake Control Valve and Trailer Air Supply Valve

### On Vehicles With Trailer Air Brake Hookup

The yellow diamond-shaped knob operates the parking brake valve. See [Fig. 3.16](#). Pull the knob out to apply both the tractor and the trailer spring parking brakes. Push the knob in to release the tractor spring parking brakes. Before the spring parking brakes can be released, the air pressure in either air brake system must be at least 65 psi (447 kPa).

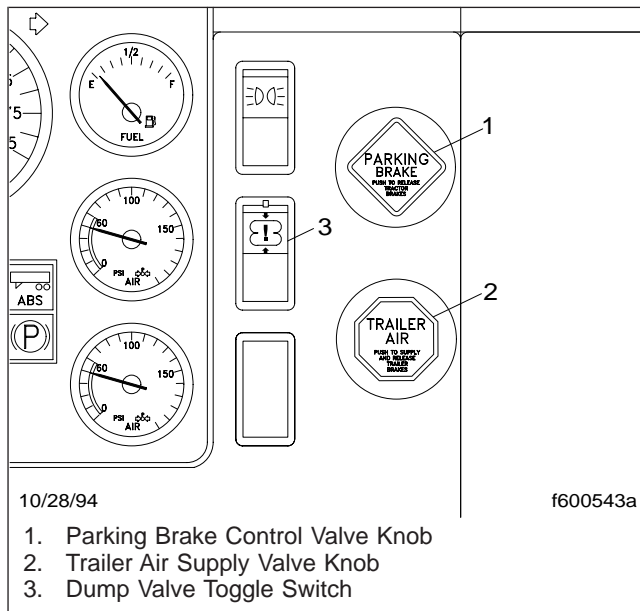

**Fig. 3.16, Brake Valves/Air Suspension Dump Valve (typical switch locations)**

The red octagonal knob operates the trailer air supply valve. See [Fig. 3.16](#). After the vehicle and its air hoses are connected to a trailer and the pressure in the air system is at least 65 psi (447 kPa), push the trailer air supply valve knob in (it should stay in) to charge the

trailer air supply system and release the trailer spring parking brakes. Before disconnecting a trailer or when operating a vehicle without a trailer, pull the trailer air supply valve knob out.

## Air Suspension Dump Valve, Optional

The air suspension dump valve allows the air in the vehicle air suspension to be quickly exhausted, lowering the rear of the vehicle. This makes it easier to connect to or disconnect from a trailer. A dump valve toggle switch on the dashboard exhausts and fills the air suspension. To prevent accidental activation, a safety release button on the switch must be pushed before the switch can toggle. See [Fig. 3.16](#).

### CAUTION

**Never exhaust air from the suspension while driving. If the air is exhausted, the suspension will not absorb road shocks and could be damaged.**

## AirLiner Plus Suspension, Optional

The AirLiner Plus suspension is used on vehicles with pusher or tag axles to improve traction performance. The system maintains an accurate leveling of frame height whether the vehicle is in motion or parked. The Meritor™ WABCO® ECAS (Electronically Controlled Air

# Driver Controls and Instruments

---

Suspension) system uses a height sensor mounted between the frame and the drive axle housing as well as other sensors to provide frame height information to a control unit mounted inside of the cab. The electronic control unit quickly lowers or raises the frame height, as necessary. Altering the height of the frame while the vehicle is parked can be performed using a hand-held remote control unit.



**Stand away from the rear of the vehicle when raising or lowering the height of the frame. The ECAS system operates quickly, and contact could result in personal injury.**

For the optional automatic function to work, the vehicle must be equipped with rear axle air suspension and ABS. Automatic Traction Control is recommended for optimal vehicle traction control.

## Parking Brake Control Valve

### Vehicles Without Trailer Air Brake Hookup

A diamond-shaped knob in the control panel operates the parking brake control valve. When the knob is out, the truck's spring parking brakes are applied. When the knob is in, the parking brakes are released. Before the parking brakes can be released, air pressure in either brake system must be at least 65 psi (447 kPa).

See [Chapter 7](#), under the heading "Air Brake System," for instructions on the use of the trailer air supply valve and parking brake valve.

## Parking Brake Control Lever On Vehicles With Hydraulic Brakes

If the vehicle is equipped with hydraulic brakes, a parking brake control lever is located on the cab floor near the gear shift lever. To apply the parking brake, depress the brake pedal, then pull up on the parking brake lever. To release the parking brake, depress the brake pedal and push the parking brake lever all the way down. Turning the knob counterclockwise decreases the effort needed to move the lever.

If the parking brake does not hold the vehicle securely, depress the brake pedal and release the parking brake. Turn the knob on the end of the lever clockwise to increase the parking brake application.

**NOTE:** Turning the knob clockwise will also increase the effort needed to apply or release the parking brake lever.

If the parking brake still doesn't securely hold the vehicle (after adjustment), check the brake lining thickness. For instructions, see **Group 42** of the *Business Class Trucks Maintenance Manual*.

## Cigarette Lighter, Optional

Push the lighter in to heat the element. The lighter will stay in until the element is hot, then it will pop out automatically.

## Turn Signal Lever

The turn signal lever is mounted on the steering column. See [Fig. 3.17](#). Pushing the lever counterclockwise turns on the left-turn signal lights; pushing it clockwise turns on the right-turn signal lights. When one of the signal lights is on, a green indicator light flashes at the far left or far right of the warning and indicator light panel. When the turn is completed, the signal will cancel and the lever will return to the neutral position.

## Hazard Warning Light Tab

The hazard warning light tab is located below the turn signal lever. See [Fig. 3.17](#). Hazard warning lights are operated by pulling the tab out. When the hazard warning light tab is pulled out, all of the turn signal lights and both of the indicator lights on the control panel will flash. To cancel the warning lights, move the turn signal lever upward or downward, then return the lever to the neutral position.

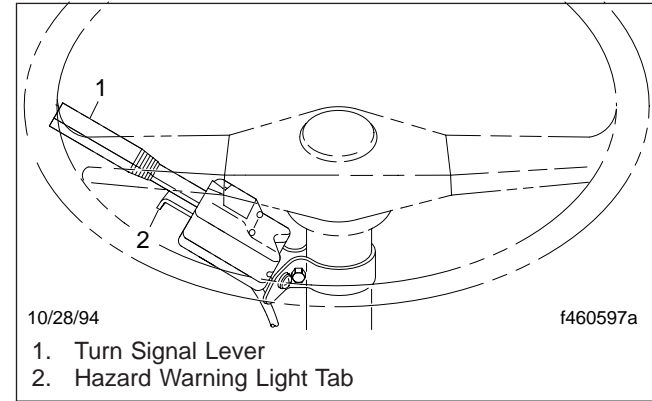

**Fig. 3.17, Turn Signal and Hazard Warning Light Switches**

## Headlight Dimmer Switch

Pull the turn signal lever upward to change from low-beam to high-beam headlights, or from high beam back to low beam. When the headlights are on high beam, a green light illuminates between the speedometer and tachometer. See [Fig. 3.17](#).

For vehicles built to operate in the United States, switching from low beams to high beams will switch off the road lights.



# Driver Controls and Instruments

NOTE: The ignition switch must be on for the high beams to work.

## Allison Automatic Transmission Controls

Allison automatic transmission models MD-CR and MD-WR are controlled by an electronic control unit (ECU). The ECU processes information from sensors, pressure switches, and the shift selector to automatically control the transmission according to programmed specifications. See [Fig. 3.18](#).

Vehicles with these transmissions have a red do-not-shift light in the lens and bezel assembly. Also, there is a service light in the indicator panel on the shift selector. With the ignition switch on, both lights come on for a few seconds, then if there is no problem with the transmission system, the lights will go out. Whenever there is a problem with the transmission system, the lights will come on and stay on as long as the problem exists.

If "service" is displayed in the indicator panel, some features may not work, but the vehicle can still be driven. If the do-not-shift light illuminates while driving (accompanied by eight short beeps from the shift selector), operating limits will be placed on the transmission, such as restricting upshifts and downshifts. However, the vehicle can still be driven to reach service assistance. In either situation, have the problem repaired as soon as pos-

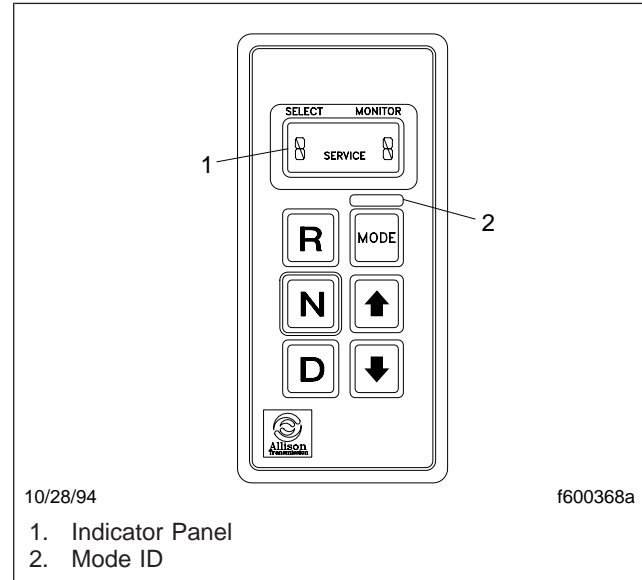

**Fig. 3.18, Shift Selector**

sible. See the *Allison Transmission Service Manual* for troubleshooting procedures.

See [Chapter 5](#) for complete transmission operating instructions.

## Suspension Seat Adjustment Controls

All adjustment controls for a suspension seat are located on the seat base. See [Chapter 2](#) for complete instructions.

## Dome Light Switches

A two-bulb dome light, with a built-in three-position switch, is mounted in the center of the rear wall just beneath the cab roof.

When the switch is in the center position, the dome light will remain off whether or not the cab doors are open.

When the driver's side of the switch is pushed in, the light will remain on whether or not the cab doors are closed.

When the passenger's side of the switch is pushed in, the light will work with the driver's door contact switch. The light will be on when the driver's door is open, and off when the door is closed. As an option, the light will work in conjunction with the driver's and passenger's door contact switches to turn the light on when either of the cab doors is open, and turn it off when they are both closed.

## Electric Horn

To sound the electric horn, push the button in the center of the steering wheel.

## Air Horn, Optional

To sound the air-operated horn, pull the cable located above the driver's door.

## Vernier Throttle Control, Optional

The vernier throttle control, located to the left of the steering column, can be used to adjust engine speed when the vehicle is parked. A "quick adjust" setting of engine speed is made by depressing the button on the control knob, then pushing in or pulling out the knob. Engine speed adjustments can then be made in smaller increments by turning the control knob in either direction.

## Tilt Steering Wheel

The tilt steering wheel has a tilt range of 15 degrees, and a telescoping range of 2-5/8 inches (67 mm). A control lever is located just below the turn signal switch on the steering column. See [Fig. 3.19](#).

After adjusting the seat to the desired ride position, unlock the steering column by pushing the control lever and holding it all the way down. Tilt the steering column to the desired position, then release the control lever to lock the steering column in place.

To adjust the height of the steering wheel, pull upward on the control lever. While holding the control lever in

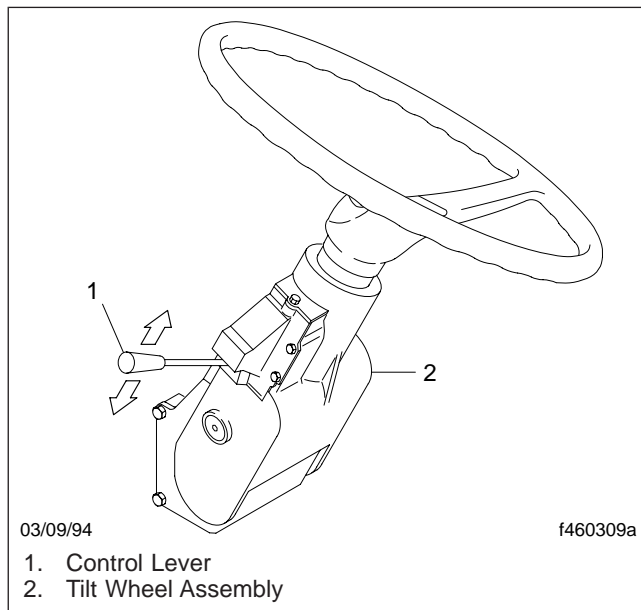

**Fig. 3.19, Tilt Wheel Assembly**

this position, move the steering wheel upward or downward to the desired position. Release the control lever to lock the steering wheel in place.

## **WARNING**

Make sure that the control lever is in the locked (neutral) position before driving the vehicle. Never try to adjust the height of the steering wheel or tilt the column while driving the vehicle. Doing so could cause loss of vehicle control, personal injury, and property damage.

## **Instrumentation Control Unit, Level I**

The instrumentation control unit, level I (level I ICU) is the standard electronic dashboard. It can accept information from the various sensors installed on the vehicle and feed it to electronic gauges. Only air gauges operate mechanically.

There can be up to eight gauges on the driver's instrument panel, six electronic and two mechanical.

The dash message center is the heart of the level I ICU. It has two parts, a set of 26 warning and indicator lights similar to those found on a conventional warning and indicator light module and a dash driver display screen. The dash driver display screen is a one-line by seven-character liquid crystal display (LCD) that normally shows odometer readings. Below this display is a

smaller one-line by three-character LCD that shows voltmeter readings.

## Warning and Indicator Lights

There can be up to 26 warning and indicator lights installed in the level I ICU. See [Fig. 3.20](#).

There are four rows of lights in the dash message center. Lights installed in the top row are optional, and their positions may vary. The lights in the bottom three rows are installed in fixed positions on all vehicles. Most are standard, but a few are optional.

- The green right- and left-turn signal lights flash on and off whenever the outside turn signals are flashing.
- The blue high-beam indicator light illuminates when the headlights are on high beam.
- The amber CHECK ENGINE indicator light illuminates if an engine condition exists such as low coolant level, high coolant temperature, or low oil pressure. It also illuminates when a fault is detected or recorded.
- The red ENGINE PROTECT warning light illuminates to indicate that the protection system available on the engine has been activated.
- The red low oil pressure (oil can symbol) warning light and buzzer activate whenever the engine oil pressure goes below a minimum level specified by the engine manufacturer (see the engine manual).
- The red high coolant temperature (thermometer symbol) warning light and buzzer activate whenever the coolant temperature goes above a maximum level specified by the engine manufacturer (see the engine manual).
- The red fasten seat belt warning light illuminates whenever the ignition switch is turned on, and stays on for 15 seconds.
- The red parking brake on (!P symbol) warning light illuminates whenever the parking brake is engaged. The buzzer sounds if the vehicle is moving at a speed greater than 2 mph (3 km/h) with the parking brake set.
- The amber RECIRC AIR indicator light illuminates whenever the ventilating system is switched to recirculated air.
- The red low air pressure (circle with arrows symbol) warning light and buzzer activate whenever air pressure in the primary or secondary air reservoir falls below 64 to 76 psi (440 to 525 kPa).
- The Trailer ABS lamp will illuminate at vehicle start-up and when there is a fault in the trailer ABS system. The lamp will only operate when a

# Driver Controls and Instruments

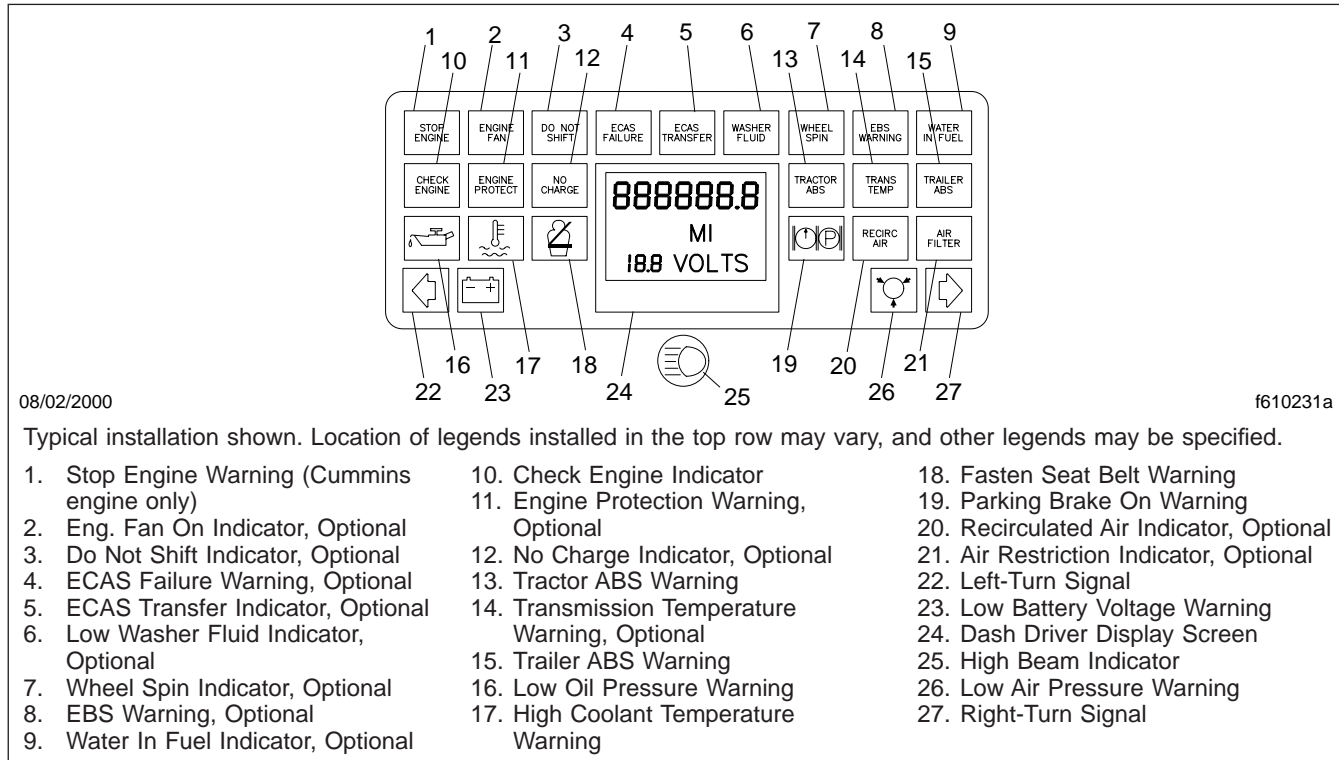

**Fig. 3.20, Level I ICU Dash Message Center**

compatible trailer is connected to the tractor before ignition. For more information, see [Chapter 7](#).

- Depending on options installed, other warning and indicator lights can be present. The optional indicator lights that are available include: alternator no charge indicator, transmission temperature warning, check transmission indicator, range inhibit indicator, air restriction indicator, engine fan on indicator, ECAS (electronic suspension) transfer indicator, ECAS failure warning, low washer fluid indicator, low battery voltage warning, EBS (electronic braking system) warning, wheel spin indicator, and water in fuel indicator.

NOTE: The functions of the ABS warning lights are explained under "Meritor™ WABCO® Antilock Braking System (ABS), Air Brake Systems" later in this chapter.

## Level I ICU Ignition Sequence

If the headlights are turned on, the screen displays the odometer and waits for the ignition to be turned on.

When the ignition is turned on, all of the electronic gauges complete a full sweep of their dials, the warning and indicator lights light up, and the buzzer sounds for three seconds. See [Fig. 3.21](#).

NOTE: The air gauges do not sweep.

The following lights go on during the ignition sequence:

- Fasten Seat Belt Warning
- Low Battery Voltage Warning
- High Coolant Temperature Warning
- Low Engine Oil Pressure Warning
- Low Air Pressure Warning
- Parking Brake On Indicator
- All engine warning lights, including Engine Protection, Check Engine, and Stop Engine (Cummins only)
- All ABS warning lights, including Wheel Spin, Tractor ABS, and Trailer ABS (if installed)

NOTE: While the engine and ABS warning lights go on during the ignition sequence, they are not controlled by the level I ICU, but by their own system ECU (electronic control unit).

Once the ignition switch has been turned on, the level I ICU performs a self-test, looking for active faults. During the first half of the self-test, all segments of the display illuminate as follows: **888888.8**. The voltmeter display also illuminates, but with the value **18.8**. During the second half of the self-test, the software revision level is displayed.

# Driver Controls and Instruments

---

If there are no active faults, the screen displays the odometer.

If the level I ICU has received active fault codes from other devices, it displays them one after the other until the parking brake is released or the ignition switch is turned off. Once the parking brake is released, the level I ICU displays the odometer again.

## Mode/Reset Switch

The mode/reset switch (**Fig. 3.22**) is located on the right side of the instrument cluster. The mode/reset switch is used to scroll through the displays on the message display screen, and to reset the trip distance and trip hours values to zero.

See **Fig. 3.23** for the state diagram for the LCD display cycle.

**NOTE:** The systems diagnostics test is used by trained personnel to retrieve fault codes and other diagnostic information pertaining to the vehicle.

When the odometer reading is displayed and the parking brake is applied:

- Press the mode/reset switch once and the trip distance will display.
- Press the mode/reset switch a second time and the trip hours (engine hours) will display.

- Press the mode/reset switch a third time and the SELECT screen and the current units, MI or KM, will display.
- Press the mode/reset switch a fourth time to return to the odometer reading.

To reset trip miles and/or trip hours to zero, press the mode/reset switch for 1 second or longer. To toggle between MI (miles) or KM (kilometers), press the mode/reset switch while in the SELECT screen.

## Warning and Indicator Lights, Right-Hand-Drive and Mechanical Engine Vehicles

For right-hand-drive and mechanical engine vehicles, a warning and indicator light module, located below the speedometer and tachometer, houses all of the standard and optional warning and indicator lights. See **Fig. 3.24**.

For all other vehicles, the warning and indicator lights are located above the speedometer and tachometer, in the level I ICU dash message center. See **Fig. 3.20**. The ICU is the control module for these lights.

On right-hand-drive and mechanical engine vehicles, all of the standard and optional warning and indicator lights

# Driver Controls and Instruments

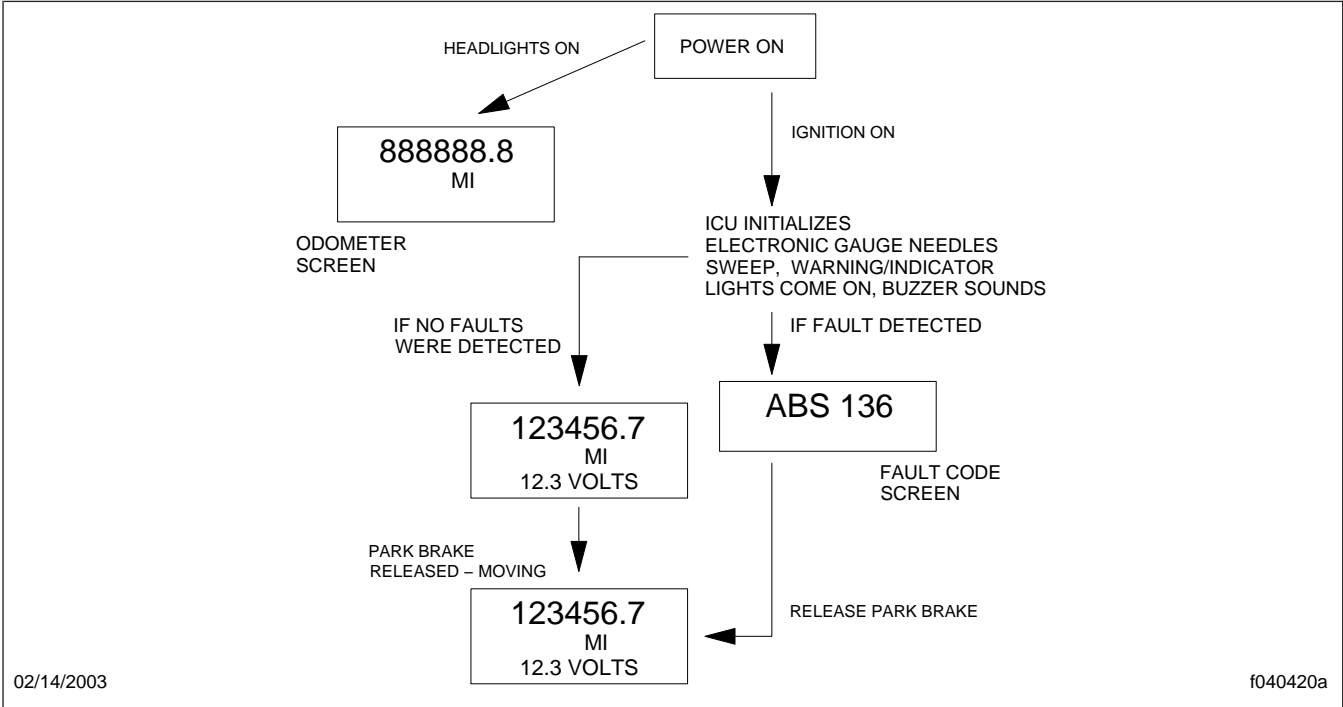
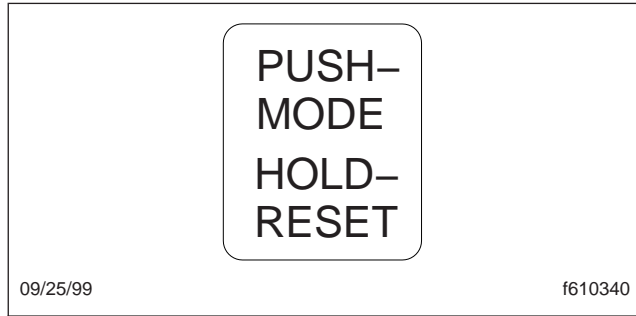

**Fig. 3.21, Level I ICU Ignition Sequence**

are housed in a lens and bezel assembly located between the speedometer and tachometer.



# Driver Controls and Instruments



**Fig. 3.22, Mode/Reset Switch**

## Standard Indicator Lights

Standard indicator lights include:

- The green right- and left-turn signal lights, which flash on and off whenever the outside turn signal lights are flashing.
- The blue high-beam indicator light, located above the speedometer and tachometer, illuminates when the headlights are on high beam.

## Standard Warning System

### Standard Warning Lights

Standard red warning lights are for alternator no-charge (battery symbol), the parking brake ("P" symbol), and the brake system (! symbol). See [Fig. 3.24](#).

The red parking brake warning light illuminates whenever the parking brakes are activated and the ignition is on.

Whenever conditions cause the brake system warning light to come on, a warning buzzer also alerts the driver.

If equipped with air brakes, the brake system warning light and buzzer activate whenever air pressure in the primary or secondary air reservoir falls below 64 to 76 psi (441 to 524 kPa).

If equipped with hydraulic brakes, the warning light goes on and the buzzer sounds when the fluid level is low or when there is a fluid pressure problem within the master cylinder. Also, the buzzer will sound when the driver's door is opened if the parking brake control lever has not been applied.

### Optional Warning and Indicator Lights

The high coolant temperature/low oil pressure (oil can/thermometer symbol) warning light and buzzer activate whenever the engine coolant temperature exceeds a preset point determined by the engine manufacturer. See [Table 3.1](#) for this temperature.

# Driver Controls and Instruments

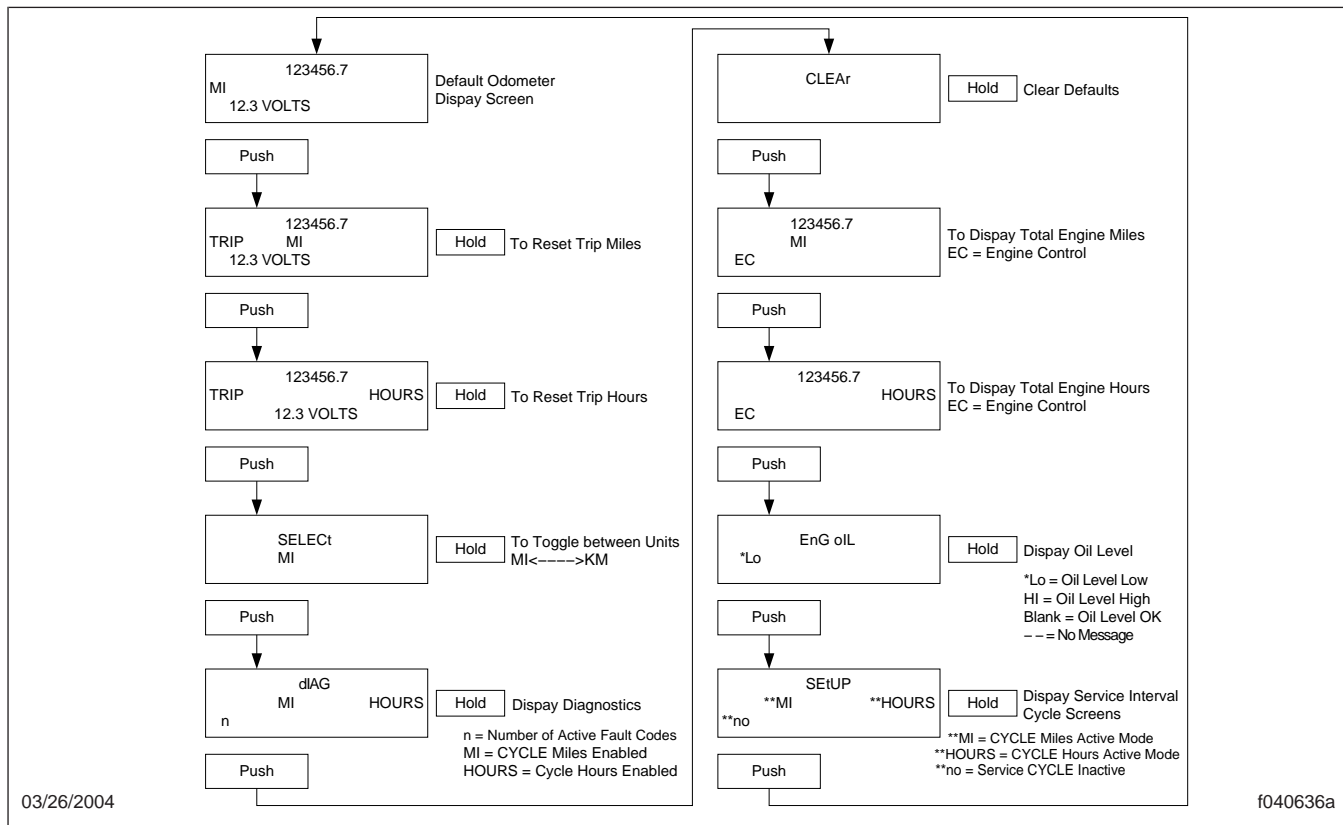
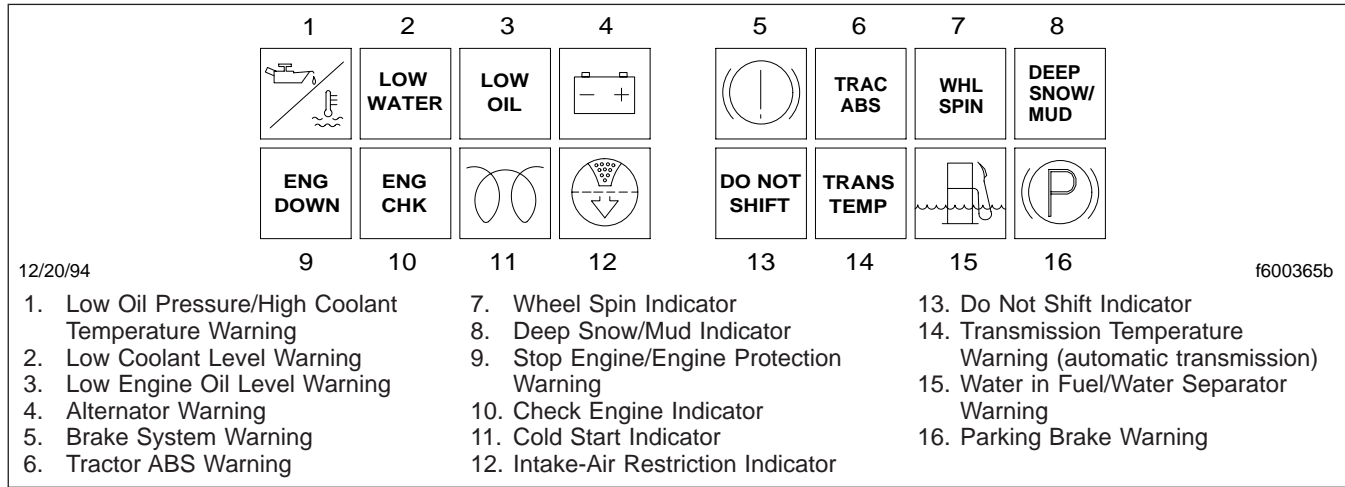

Fig. 3.23, ICU3 Mode Reset LCD Display Cycle

# Driver Controls and Instruments



- |   |   |   |
|---|---|---|
| <ul style="list-style-type: none"> <li>1. Low Oil Pressure/High Coolant Temperature Warning</li> <li>2. Low Coolant Level Warning</li> <li>3. Low Engine Oil Level Warning</li> <li>4. Alternator Warning</li> <li>5. Brake System Warning</li> <li>6. Tractor ABS Warning</li> </ul> | <ul style="list-style-type: none"> <li>7. Wheel Spin Indicator</li> <li>8. Deep Snow/Mud Indicator</li> <li>9. Stop Engine/Engine Protection Warning</li> <li>10. Check Engine Indicator</li> <li>11. Cold Start Indicator</li> <li>12. Intake-Air Restriction Indicator</li> </ul> | <ul style="list-style-type: none"> <li>13. Do Not Shift Indicator</li> <li>14. Transmission Temperature Warning (automatic transmission)</li> <li>15. Water in Fuel/Water Separator Warning</li> <li>16. Parking Brake Warning</li> </ul> |
|---|---|---|

**Fig. 3.24, Warning and Indicator Lights (right-hand-drive and mechanical engine vehicles)**

Maximum Coolant Temperature	
Engine Model	°F (°C)
Mercedes-Benz MBE900	222 (105)
Caterpillar (all models)	210 (99)
Cummins M11 and C Series	212 (100)
Cummins B Series	210 (99)
Detroit Diesel	210 (99)

**Table 3.1, Maximum Coolant Temperature**

The high coolant temperature/low oil pressure warning light and buzzer also activate whenever the oil pressure falls below the minimum oil pressure recommended by the engine manufacturer. See [Table 3.2](#).

# Driver Controls and Instruments

Oil Pressure *		
Engine Model	Oil Pressure at Idle Speed psi (kPa)	Oil Pressure at Rated Speed psi (kPa)
Mercedes-Benz MBE900	7 (50) min.	36 (250) min.
Caterpillar C-10	10 to 20 (69 to 138)	30 to 45 (207 to 310)
Caterpillar C-12	10 (69) min.	45 (310) min.
Cummins M11	10 (69) min.	35 to 45 (241 to 310)
Cummins B and C Series	10 (69) min.	30 (207) min.
Detroit Diesel	12 (83) min.	50 (345) min.

\* Oil pressures are given with the engine at operating temperature. With the engine cold, oil pressures may be higher.

**Table 3.2, Oil Pressure**

Other optional warning or indicator lights may include: intake air preheater, oil level, automatic transmission fluid temperature, low coolant level, do-not-shift, check transmission, range inhibit, intake-air restriction, check engine, engine protection.

When the ignition is turned on, oil- and brake-system warnings (as equipped) activate until the engine starts and minimum pressures are exceeded. If the low-oil warning light or brake system warning light remains lit after running the engine for 15 seconds, shut down the

engine and determine the cause. See the vehicle service manual for repair procedures.

**IMPORTANT:** If the warning system does not activate when the ignition is turned on, repair the system to provide warning protection for oil pressure, coolant temperature, and the brake system.

## Kysor Vehicle Protection System, Optional

The Kysor system is an electronically-controlled warning and engine shutdown system. See [Fig. 3.24](#).

### Engine Functions

The system monitors engine coolant temperature, coolant level, and oil pressure.

- If the engine overheats, a warning light illuminates and a buzzer sounds. The temperature that triggers the warning light and buzzer varies with engine type and is programmed into the system at the factory. If the temperature continues to rise to critical levels, the engine protection light illuminates and the engine will shut down.
- If the coolant level drops below a sensor in the cooling system, the low coolant level light illuminates and a buzzer sounds. After 30 seconds, the system will shut down the engine.

# Driver Controls and Instruments

- If the engine oil pressure drops below a preset level, the low oil pressure light illuminates and a warning buzzer sounds. If the oil pressure drops to a preset critical level, the engine protection light illuminates and the engine will shut down.
- All shutdown features have an automatic override. If the vehicle needs to be moved to a safe location after a shutdown, just start the engine. It will run for about 30 seconds before shutting down again.

## Meritor™ WABCO® Antilock Braking System (ABS), Air Brake Systems

The Meritor WABCO Antilock Braking System (ABS) may have the following warning lights: a tractor warning (TRAC ABS) light, a wheel spin (WHL SPIN) indicator light, and a DEEP SNOW/MUD indicator light. See [Fig. 3.24](#).

If equipped with the tractor ABS system, the tractor warning (TRAC ABS) light illuminates after the engine is started. See [Fig. 3.24](#). Once the vehicle moves faster than about four mph (six km/h), the warning light goes out only if all of the tractor's ABS components are working.

The wheel spin (WHL SPIN) indicator light illuminates if one of the drive wheels spins during acceleration. See [Fig. 3.24](#). The light goes out when the wheel stops

spinning. A label on the dash explains what actions should be taken when the wheel spin indicator light illuminates. See [Fig. 3.25](#).

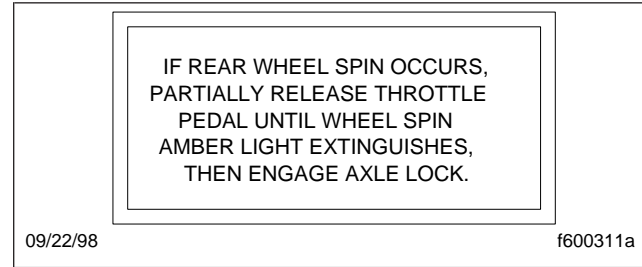

**Fig. 3.25, Dash Label**

If equipped with an electronic engine, an automatic traction control (ATC) system may be installed. On these vehicles, the ATC system automatically reduces wheel spin during reduced-traction starts.

An "ATC Function" switch (if equipped), may be used under more adverse conditions. Turning on this switch illuminates the DEEP SNOW/MUD indicator light. The ATC system now allows some wheel spin (for example, to help burn through a thin layer of ice) during reduced-traction starts. See [Fig. 3.24](#).

**IMPORTANT:** If any of the ABS warning lights do not work as described above, or come on while

driving, repair the ABS system immediately to ensure full antilock braking capability.

An ABS CHK switch is located below the dash panel on the right side of the steering column, and is used to read system fault codes on the WHL SPIN light. See **Section 42.36** of the *Business Class® Trucks Service Manual* for troubleshooting procedures.

**IMPORTANT:** If the vehicle is equipped with the ATC system, turning on the ABS CHK switch will reduce engine speed to idle. This will occur whether the vehicle is stopped or is being driven. Also, the WHL SPIN light will come on. If these conditions occur, turning the ABS CHK switch off will return the engine to full function capability.

See the brake system operating instructions in **Chapter 7** for more information.

## Meritor™ WABCO® Antilock Braking System (ABS), Hydraulic Brake Systems

If equipped with the ABS system, the dash warning light (TRAC ABS) illuminates after the engine is started. See **Fig. 3.24**. Once the vehicle moves faster than about four mph (six km/h), the warning light goes out only if all of the tractor's ABS components are working.

**IMPORTANT:** If the TRAC ABS warning light does not work as described above or illuminates while driving, repair the ABS system immediately to ensure full antilock braking capability.

An ABS CHK switch is located below the dash panel on the right side of the steering column and is used to read system fault codes on the TRAC ABS light. See **Section 42.36** of the *Business Class® Trucks Service Manual* for troubleshooting procedures.

See the brake system operating instructions in **Chapter 7** for more information.

## Bendix Antilock Braking System (ABS)

With the Bendix Antilock Braking System (ABS), the tractor warning light (TRAC ABS) illuminates after the key is turned on. The warning light goes out only if all of the tractor's ABS components are working properly. See **Fig. 3.24**.

Vehicles equipped with a Bendix ABS system may also be equipped with an automatic traction control (ATC) system. The ATC system automatically controls wheel spin during reduced-traction starts.

The wheel spin indicator light (WHL SPIN) illuminates if one of the drive wheels spins during acceleration). The

# Driver Controls and Instruments

---

light goes out when the wheel stops spinning. The Bendix system will either reduce engine torque or apply gentle brake pressure to force the differential to drive the stationary or slowly spinning wheel. If slippery road conditions continue, engage the axle lock. See **Fig. 3.24**.

**IMPORTANT:** If any of the ABS warning lights do not work as described above, or come on while driving, repair the ABS system immediately to ensure full antilock braking capability. See **Group 42** in the *Business Class® Trucks Service Manual* for troubleshooting procedures.

See the brake system operating instructions in **Chapter 7** for more information.

## Collision Warning System (CWS), Eaton VORAD EVT-300, Optional

The Eaton VORAD EVT-300 is a computerized collision warning system (CWS) that uses front-mounted and side-mounted (optional) radar to continuously monitor vehicles ahead of and alongside your vehicle.

The system warns of potentially dangerous situations by means of visual and audible alerts. The system performs in fog, rain, snow, dust, smoke, and darkness. To

be detected, objects must be within the radar beam's field of view and provide a surface area that can reflect back the radar beam.

The front-looking antenna assembly transmits radar signals to, and receives them back from, vehicles and objects ahead. This allows the determination of the distance to, relative speed of, and angle to the target of vehicles and objects ahead. The system uses this information to warn the driver of potentially dangerous situations.

Optional side sensor(s) mounted on the side of the vehicle also transmit and receive radar signals for a distance of 2 to 10 feet (0.5 to 3 meters) alongside your vehicle. The side sensor(s) provide a 15 degree vertical by 15 degree horizontal beam pattern. The side sensor(s) can detect unseen vehicles and objects moving and stationary adjacent to your vehicle.



**The Eaton VORAD EVT-300 Collision Warning System (CWS) is intended solely as an aid for an alert and conscientious professional driver. It is not intended to be used or relied upon to operate a vehicle. Use the system in conjunction with rearview mirrors and other instrumentation to safely operate the vehicle. Operate this vehicle, equipped with the EVT-300 Collision Warning System, in the same**

safe manner as if the EVT-300 Collision Warning System were not present.

**The EVT-300 Collision Warning System is not a substitute for safe, normal driving procedures, nor will it compensate for any driver impairment, such as drugs, alcohol, or fatigue.**

**The EVT-300 Collision Warning System may provide little or no warning of hazards such as pedestrians, animals, oncoming vehicles, or cross traffic.**

**Failure to drive safely and use the system properly could result in personal injury and/or death and severe property damage.**

## Driver Display Unit (DDU)

NOTE: All system controls are located on the DDU. See [Fig. 3.26](#). Indicators to inform the driver about the system's operation are located on both the DDU and the optional side sensor display.

The DDU controls system power, range for vehicle warnings, speaker volume, and all other system functions. At the lower front edge of the DDU, a slot is provided to insert the optional driver's identification card. Alert and indicator lights advise of multiple warning levels, system power, system failure, and, if so configured, failure of the driver to insert the identification card.

A light sensor automatically adjusts alert and indicator light brightness depending on cab lighting conditions. A small speaker provides audible alert tones to warn of closing on an object ahead and, when equipped with an optional side sensor, of objects alongside when the turn signal is activated in preparation for a lane change. Additional tones indicate speaker volume, system failure, driver's card status, and data extraction pass or fail.

1. The green power-on/driver's card (optional) status indicator light illuminates when the system is activated and the power-on LED test is complete. If the system is configured to require that the driver's card be read, and it is not, the ON light blinks continuously.
2. Push in the volume control and power ON/OFF knob to turn power on or off. Turn the knob left or right to increase or decrease speaker volume. Press and hold the knob for 5 seconds and then release it to activate the failure display mode.

NOTE: The system may be configured to have no on/off capability and the volume may be configured to allow only some volume control.

3. The speaker is located under the top cover of the DDU. It sounds audible tones to alert the driver to potential hazards. Volume may be restricted to a range above a minimum level.



# Driver Controls and Instruments

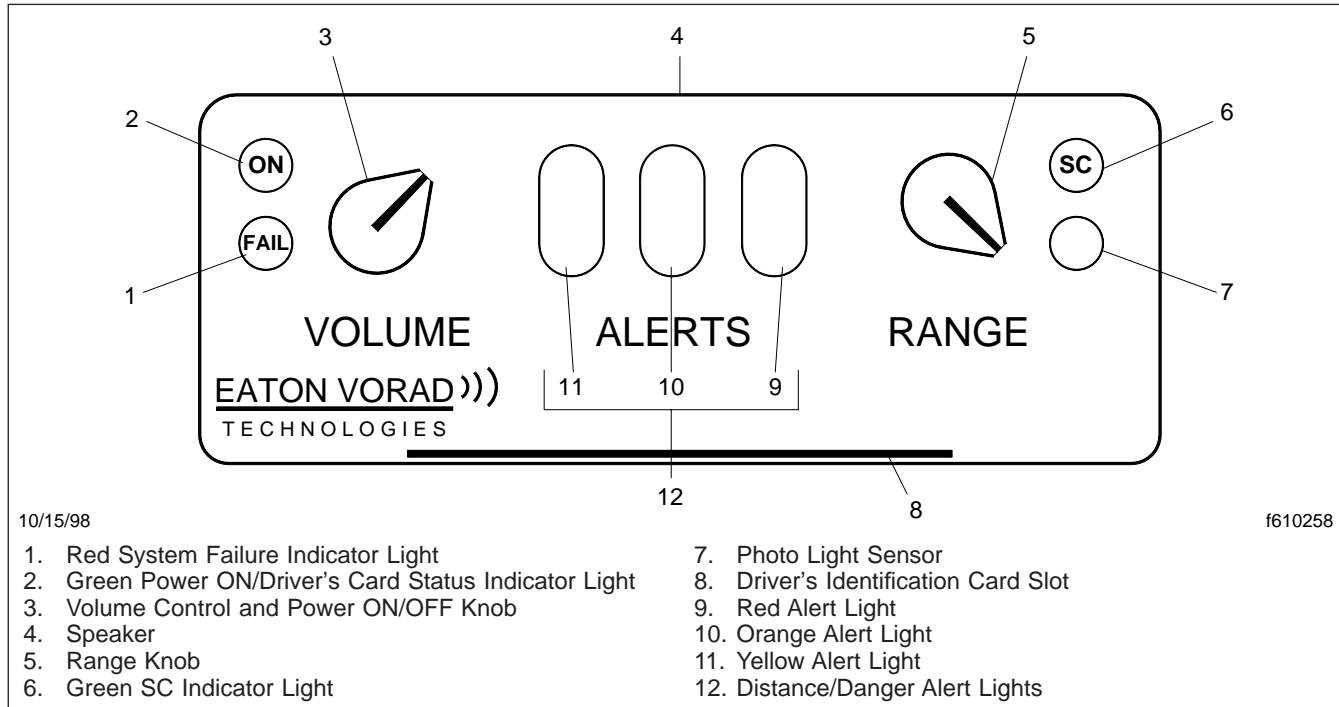

10/15/98

f610258

**Fig. 3.26, Driver Display Unit, EVT-300**

NOTE: This is a configurable electronic parameter.

4. Rotate the range knob (if enabled) to change the first alert detection range from 3 to 2 seconds. This

# Driver Controls and Instruments

will also change the second alert detection range from 2 to 1.75 seconds. Push and hold the knob for 5 seconds to activate the accident reconstruction function and freeze the most recent data in half of the allocated memory.

**NOTE:** The system may be configured to prevent adjustment of the range levels.

5. The red system failure indicator light illuminates if a system problem is detected. Press and hold the volume control knob for 5 seconds to display fault codes. The fault codes will be blinked out as a pattern of flashes on this indicator light. See [Table 3.3](#) for fault codes.

Fault Codes (blink codes)	
Fault Code	Suspect Failure
11	Central Processing Unit (CPU)
12	CyberCard
13	Driver Display Unit (DDU)
14	Antenna Assembly
15	Right Side Sensor
16	Left Side Sensor
21	Right-Turn Signal
22	Left-Turn Signal
23	Brake
24	Speed

Fault Codes (blink codes)	
Fault Code	Suspect Failure
25	SmartCruise
31	J1587
32	J1939
33	VBUS
34	DDU Communications
35	Antenna Assembly Communications
41	No Fault or End of Fault Codes

**Table 3.3, Fault Codes or Blink Codes**

6. The green SC indicator light will flash 8 times if the range knob is pressed to store accident reconstruction information. It will also flash 8 times after the system is activated, after the power-on LED test is finished, and if accident reconstruction data was previously stored.
7. The photo light sensor senses lighting conditions in the cab and automatically adjusts the intensity of the indicator and alert lights.
8. If the system's configuration requires, insert the driver's identification card in the slot at the lower front edge of the DDU. A high-pitched tone will sound when the driver's identification card has been successfully read. One low tone will sound if the driver's card has been unsuccessfully read. If so configured, a repeated low tone will sound if the

# Driver Controls and Instruments

---

system is on and the requested driver's card has not been inserted.

9. The yellow alert light illuminates when an object is detected within the system's maximum range of 350 feet (107 meters) on a straight road. Range is reduced in curves by the turn radius of the curve. This light also illuminates when the proximity alarm threshold is crossed.
10. The yellow and orange alert lights illuminate when your vehicle is within a 3-second following interval behind another vehicle in the same lane. If you are within a 2-second following interval, and closing on the vehicle ahead, a warning tone will also sound.
11. The yellow, orange, and red alert lights illuminate when you are 1 second (and less than 1 second) behind a vehicle. If the vehicle ahead is opening the interval, no tone will sound. If you are closing the interval, double tones will sound. Within a 1/2-second or less following interval, opening or closing, the tones will repeat twice per second.
12. If a stationary vehicle or object, or an object moving less than 3.4 mph (5.5 km/h) in the same lane is detected within 220 feet (67 meters) and within 3 seconds, all three alert lights will illuminate and the double tones will sound. This warning overrides all others and is not affected by the range control knob setting.

**IMPORTANT:** The system is disabled in turns with a radius of less than 750 feet (230 meters) and when the brakes are applied.

13. If your vehicle is traveling less than 2 mph (3 km/h) and an object is detected less than 15 feet (4.5 meters) in front of your vehicle, and the closing rate is more than 1/2 mph (1 km/h), the yellow alert light will illuminate and a low-frequency double tone will sound. This is the proximity alert.

**NOTE:** All warnings apply only to objects within the maximum detection range and in your lane. Proximity alert tones and vehicle-closing 1/2-second and 2-second following interval tones are configured items. All tones are disabled in sharp turns or when the brakes are applied. If the configuration permits, the 3-second and 2-second alert levels may be adjusted with the range control knob. A single low-frequency tone sounds when a system failure is detected. A medium-frequency tone sounds when the volume control level is changed. Successful downloading of Eaton Vehicle Information Management System (EVIMS) data will cause a double tone to sound. Unsuccessful downloading will cause a low-frequency tone to sound.

14. A failure of the optional side sensor(s) will cause a continuous red light on the side sensor display to appear.

## Side Sensor Display, Optional

1. The yellow indicator light illuminates continuously when no vehicle is detected by the side sensor(s). See [Fig. 3.27](#).
2. The photo light sensor senses lighting conditions in the cab and automatically adjusts the intensity of indicator and alert lights.
3. The red alert light illuminates when objects are detected by the side sensor(s). If the right turn signal is activated and the side sensor detects an object, the red alert light will illuminate and the DDU speaker will sound a high-frequency double tone. This tone is sounded only once per activation of the turn signal. The red light will also illuminate and stay on if a failure of the side sensor is detected.

## Special Road Situations



The Eaton VORAD EVT-300 Collision Warning System (CWS) is intended solely as an aid for an alert and conscientious professional driver. It is not in-

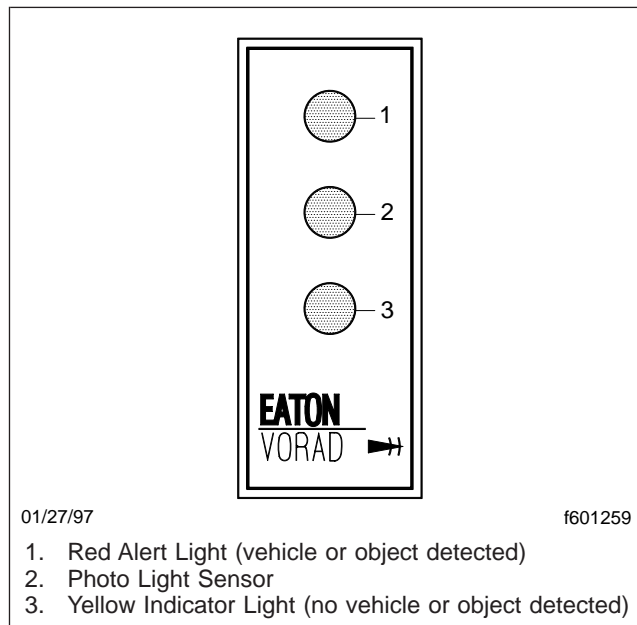

**Fig. 3.27, Side Sensor Display, Optional**

tended to be used or relied upon to operate a vehicle. Use the system in conjunction with rearview mirrors and other instrumentation to safely operate

# Driver Controls and Instruments

---

the vehicle. This system will not warn of many possible hazards. Do not assume it is "all clear" if no alert lights are illuminated.

**Failure to drive safely and use the system properly could result in personal injury and/or death and severe property damage.**

Certain special road situations may affect the system's ability to detect objects. These situations include the effects of curves, dips, and hills which can provide an unexpected result:

**NOTE:** A warning may sound when an object is detected in front of the vehicle even though the driver intends to turn away or stop before reaching the object.

- When an object is detected in a very sharp right- or left-hand turn, the audible alarm will not sound.
- When approaching a curve, before turning into it, alarms may sound and lights illuminate because of an object off of the road, directly in line with your vehicle. This will not occur when the brakes are applied.
- Elevated obstacles, such as overpasses and overhead signs, may be detected when approaching a roadway descending to a lower elevation.

- Vehicles cannot be detected on the other side of a hill. An alarm will not sound until the object is within the antenna assembly's field of view.
- On approaching a steep hill, objects above the beam cannot be detected. Generally, the beam hitting the road surface does not cause an alarm.
- The side sensor only detects objects within its field of view, next to your vehicle. A vehicle farther back, behind the field of view, will not be detected.
- The side sensor range is set to detect average sized vehicles, 2 to 10 feet (0.5 to 3 meters) away, in the adjacent lane. The side sensor provides a 15 degree vertical by 15 degree horizontal beam pattern.
- The radar beam of the CWS will detect near range cut-ins of approximately 30 feet (9 meters) or less, depending on the angle of entrance into the lane in front of your vehicle.



**Heavy rain or water spray at the side sensor may temporarily prevent the system from providing adequate warnings.**

**Failure to drive safely and use the system properly could result in personal injury and/or death and severe property damage.**

NOTE: A continuous fixed object on the right side of the vehicle such as a guard rail, wall, tunnel, or bridge may cause the side sensor alert light to stay on.

## In Case of Accident

The optional vehicle accident reconstruction capability provides two segments of system data, one of which can be stored in system memory. Push and hold the DDU range knob for at least 5 seconds to store the first segment. Within 6 seconds, the green SC indicator light will blink rapidly 8 times, confirming that the data has been saved. If the range knob is pushed again, a fail tone will sound. After the first segment is saved, the second segment runs continuously, but only contains the last 10 minutes (approximately) of system data. The system will cease recording data 30 seconds after the vehicle comes to a stop.

NOTE: Once the first memory segment is frozen, the other can't be frozen. Only by disconnecting the main CPU connector can the second memory segment be preserved. If you desire immediate downloading and interpretation of accident reconstruction data, you must return the CPU to Eaton

VORAD. However, after 30 days the frozen information will automatically clear if the vehicle is driven.

## Maintenance and Diagnostics

1. Keep the antenna assembly and side sensor(s) free of a buildup of mud, dirt, ice, or other debris that might reduce the system's range.
2. The system tests itself continuously and evaluates the results every 15 seconds. If a problem is detected with the front radar system, the red FAIL light on the DDU illuminates continuously as long as the failure is active. The corresponding fault code is stored in the CPU's memory.
3. Both active and inactive fault codes can be indicated by the DDU when the system is placed in failure display mode. Inactive faults are those that have occurred and have cleared. Active faults are still present. Fault codes provide the driver the ability to record the system faults during a trip and to notify his maintenance department or Eaton VORAD. See "Failure Display Mode/Fault Codes" below. In this mode, specific fault codes are indicated by the pattern of blinks of the driver display unit red FAIL light.

# Driver Controls and Instruments

---

- Each fault code is a two-digit number, as shown in **Table 3.3**. The red FAIL light blinks the same number of times as the first digit, a pause of approximately 3/4 of a second follows, then the light blinks the same number of times as the second digit.
- Additional fault codes are blinked out at intervals of approximately 3 seconds. After all the fault codes have been blinked out, a code 41 will be blinked out.

## Failure Display Mode/Fault Codes

NOTE: If the vehicle does not have ON/OFF control on the DDU, press and hold the volume knob after the ignition key is turned on and the 15-second self-test is complete.

- Press and hold the DDU volume control and power ON/OFF knob for at least 9 seconds. The system will turn off if you release the knob before 9 seconds. After 9 seconds, the DDU FAIL light begins to blink out the fault codes. After a 3-second interval additional fault codes, if present, will be blinked out. A code 41 will be blinked out either if no faults are found or when all fault codes have been blinked out.
- Position the DDU range knob to the left to blink active fault codes and to the right to blink inactive codes.

- To review, test, and clear all fault codes from system memory, use a hand-held diagnostic tool or ServiceRanger.

## Instruments

For the standard electronic engine gauge layout, see **Fig. 3.28**.

For the standard gauge layout for right-hand-drive and mechanical engine vehicles, see **Fig. 3.29**.

## Speedometer

A speedometer registers vehicle speed in both miles per hour (mph) and kilometers per hour (km/h). Standard speedometer gauges are equipped with an odometer that records total distance traveled in either miles or kilometers.

## Tachometer, Optional

A tachometer indicates engine speed in revolutions per minute (rpm) and serves as a guide for shifting the transmission and keeping the engine in the appropriate rpm range. For low idle and rated rpm, see the engine identification plate.

The tachometer may include an engine hour meter. An engine hour meter records continuous operating hours of the engine. In cases where actual mileage does not

# Driver Controls and Instruments

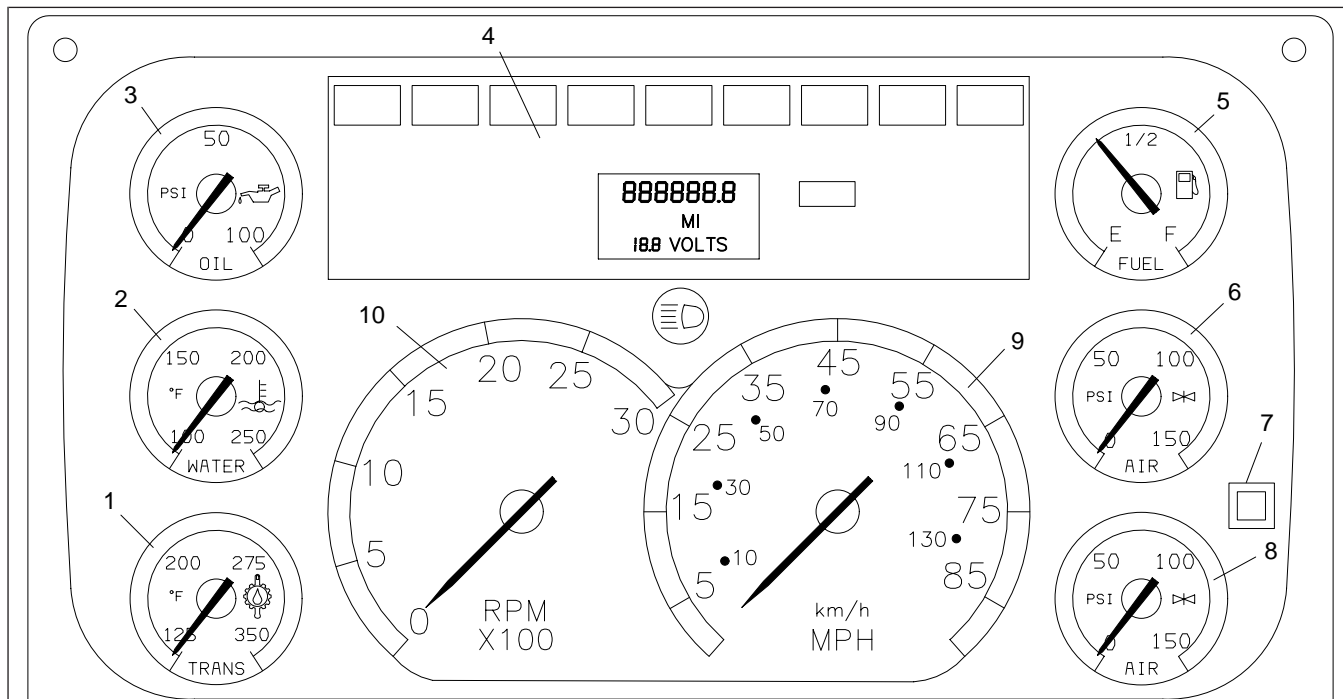

02/17/2000

f610205d

1. Transmission Temperature Gauge, Optional
2. Coolant Temperature Gauge
3. Engine Oil Pressure Gauge
4. Dash Message Center
5. Fuel Gauge

6. Primary Air Pressure Gauge
7. Mode/Reset Push Button, Optional
8. Secondary Air Pressure Gauge
9. Speedometer
10. Tachometer, Optional

Fig. 3.28, Typical Gauge Layout, Electronic Engine Vehicles



# Driver Controls and Instruments

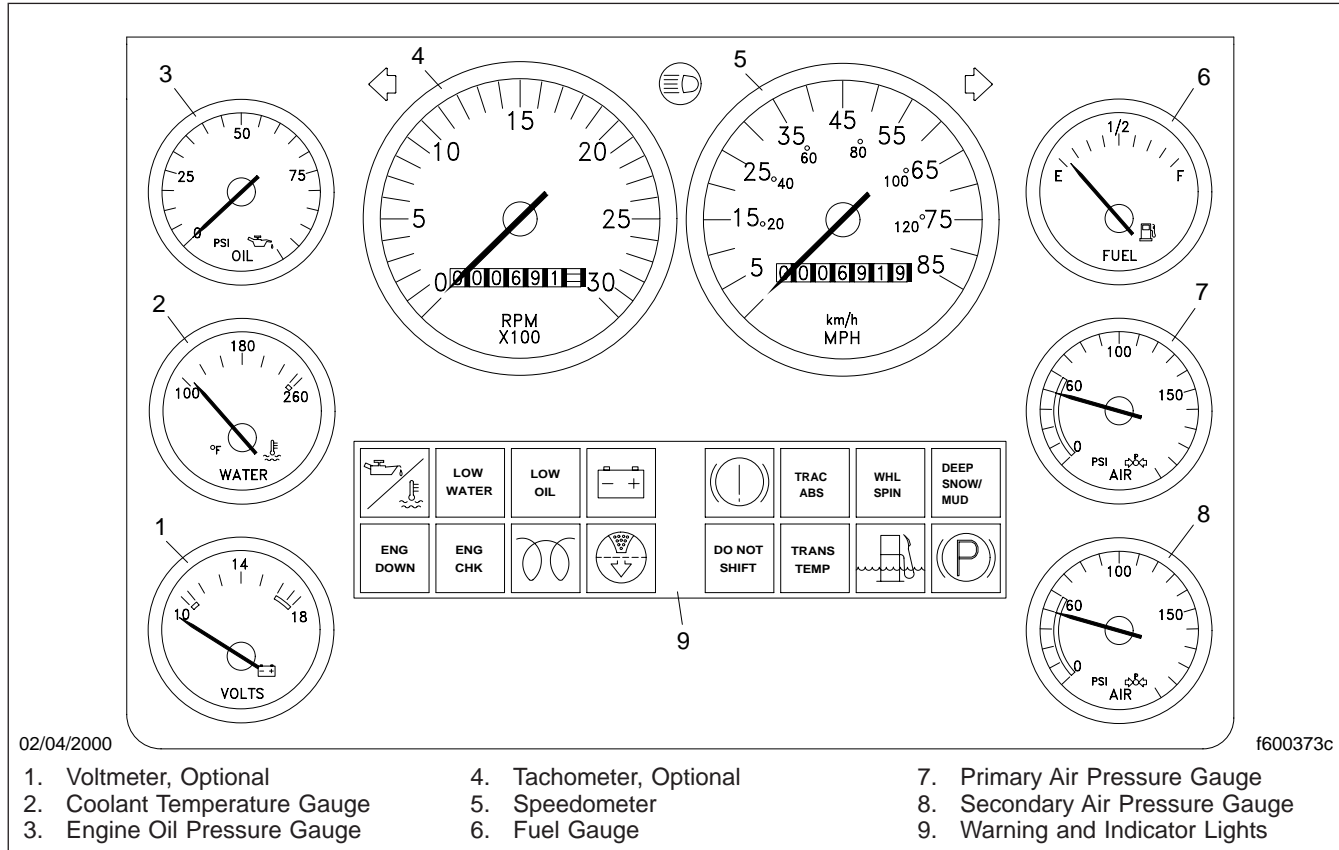

**Fig. 3.29, Typical Gauge Layout (right-hand-drive and mechanical engine vehicles)**

indicate overall usage, maintenance and lubrication intervals for the engine and engine-operated equipment can be determined by operating hours.

## Coolant Temperature Gauge

During normal engine operation, the coolant temperature gauge should read 175 to 203°F (79 to 95°C). If the temperature remains below 160°F (71°C) or exceeds the maximum temperature shown in [Table 3.1](#), inspect the cooling system to determine the cause. See **Section 20.00** of the *Business Class® Trucks Service Manual* for troubleshooting and repair procedures.

## Engine Oil Pressure Gauge

The oil pressure gauge should read as shown in [Table 3.2](#).



### CAUTION

**A sudden decrease or absence of engine oil pressure may indicate mechanical failure. Bring the vehicle to a safe stop, and investigate the cause to prevent further damage. Do not operate the engine until the cause has been determined and corrected.**

## Voltmeter, Optional

The voltmeter gauge is optional on the control panels without an ICU. On the ICU control panels, the voltmeter readings are displayed on the lower line on the dash message center.

The voltmeter indicates the vehicle charging system voltage when the engine is running and the battery voltage when the engine is stopped. By monitoring the voltmeter, the driver can be aware of potential charging system problems and have them fixed before the batteries discharge enough to create starting difficulties.

The voltmeter will normally show approximately 13.7 to 14.1 volts when the engine is running. The voltage of a fully charged battery is 12.7 to 12.8 volts when the engine is stopped. A completely discharged battery will produce only about 12.0 volts. The voltmeter will indicate lower voltage as the vehicle is being started or when electrical devices in the vehicle are being used.

If the voltmeter shows an undercharged or overcharged condition for an extended period, have the charging system and batteries checked at a repair facility.

On a vehicle equipped with a battery isolator system, the voltmeter measures the average voltage of all of the batteries when the engine is running. When the engine is stopped, the voltmeter shows only the gel cell battery voltage and does not indicate the voltage of the engine-starting batteries.

# Driver Controls and Instruments

## CAUTION

Gel cell batteries can be damaged if the battery voltage is allowed to drop below 12.0 volts or if the charging voltage is more than 14.1 volts. Start the engine to recharge the gel cell before the battery becomes fully discharged. If an external charger is needed, disconnect the gel cell battery and use only an external battery charger that has been approved for gel cell batteries.

## Primary and Secondary Air Pressure Gauges

These air pressure gauges register the constant pressure in the primary and secondary air systems. Normal pressure, with the engine running, is 95 to 125 psi (655 to 862 kPa) in both systems. A low-air-pressure warning light and buzzer connected to both the primary and secondary systems, activate when air pressure in either system drops below a minimum pressure of 62 to 68 psi (427 to 469 kPa). When the engine is started, the warning light and buzzer remain on until air pressure in both systems exceeds minimum pressure. An air pressure gauge that registers pressure in both the primary and secondary systems may be installed on some vehicles.

## Fuel Gauge

The fuel gauge indicates the amount of fuel in the fuel tank(s).

## Intake-Air Restriction Indicator

An intake-air restriction indicator measures the vacuum on the engine side of the air cleaner at the air cleaner outlet. See [Fig. 3.30](#). If the yellow signal stays locked at or above the values shown in [Table 3.4](#) after the engine is shut down, service the air cleaner, then reset the indicator by pressing the reset button.

Intake-Air Restriction	
Engine Model*	Service at or Above
Mercedes-Benz MBE900	22 inH <sub>2</sub> O
Caterpillar	25 inH <sub>2</sub> O
Cummins	25 inH <sub>2</sub> O
Detroit Diesel	25 inH <sub>2</sub> O

\* Turbocharged engines must be checked at full load and governed engine speed.

**Table 3.4, Intake-Air Restriction**

NOTE: Avoid opening the air cleaner and disturbing the seals or filter element until the yellow signal stays locked at or above the value shown in [Table 3.4](#). When this occurs, the air cleaner needs

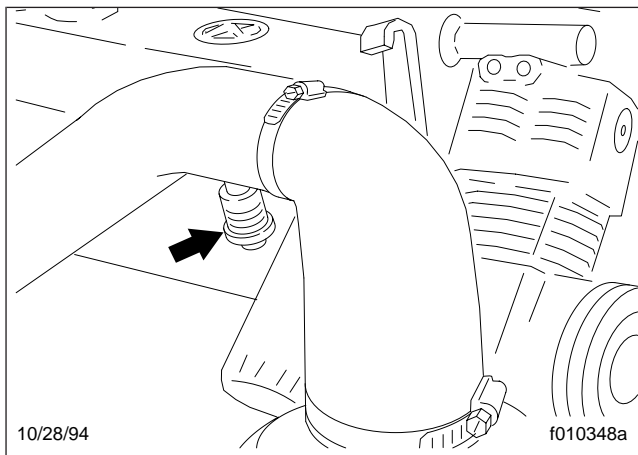

**Fig. 3.30, Intake-Air Restriction Indicator (installation typical)**

replacing; however, immediate engine shutdown is not necessary.

## Transmission Oil Temperature Gauge, Optional

With an Allison automatic transmission, the transmission oil temperature gauge reading should not exceed 250°F (121°C) during normal operation. A warning light will activate to alert the driver.

## ! CAUTION

A sudden increase in transmission oil temperature that is not caused by a load increase may indicate mechanical failure. Bring the vehicle to a safe stop and investigate the cause to prevent further damage. Do not operate the vehicle until the cause has been determined and corrected.

## Heater and Air Conditioner

A dash-mounted climate control panel allows you to control all of the heating, air conditioning, defrosting, and ventilating functions. See [Fig. 3.31](#) or [Fig. 3.32](#).

A three-speed fan switch controls the flow of fresh or recirculated air to any selected air outlets at the windshield, door windows, dashboard face, and cab floor. If equipped with air conditioning, an on/off control lever is installed with the fan switch.

An air selection switch controls the direction of warm or cool air either to the feet, to feet and windshield, or to the windshield (defrost).

If equipped with air conditioning, the air selection switch controls the direction of warm or cool air either to the face, to face and feet, to feet and windshield, or to the windshield (defrost). An air-source lever is also used to

# Driver Controls and Instruments

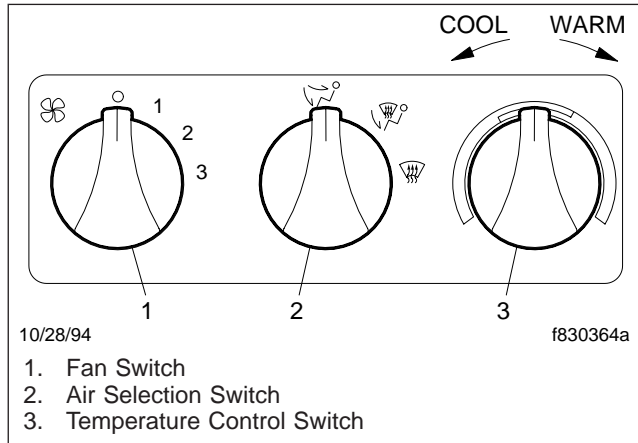
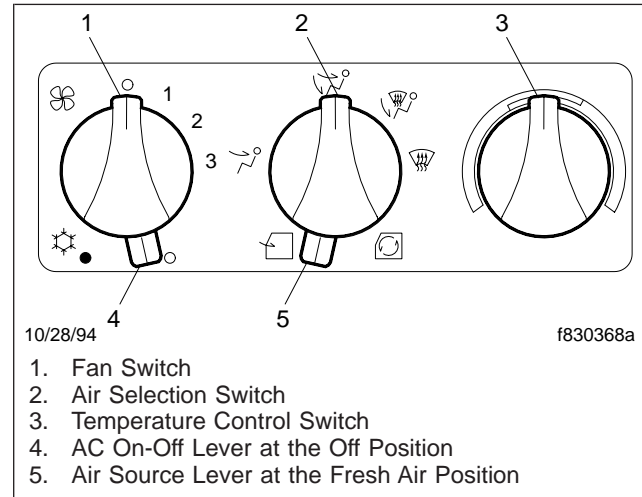

**Fig. 3.31, Climate Control Panel, Equipped With Heater Only**

control the mixing of recirculated cab air with fresh air from the outside.

A temperature control switch is used to select the desired temperature. Turn the switch counterclockwise for cool air, or clockwise for warm air.

All of the dash-face outlets have adjustable louvers that pivot right and left, and up and down. Close an outlet by moving the lever all the way up or, open an outlet by moving the lever all the way down. See [Fig. 3.33](#).

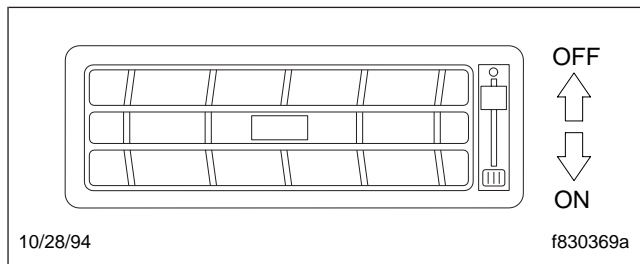

**Fig. 3.32, Climate Control Panel, Equipped With Heater and Air Conditioner**

Windshield defrost outlets can be moved to direct air flow, but the door window defrost outlets have nonadjustable louvers.

See [Fig. 3.34](#) for location and function of all dash outlets.

**IMPORTANT:** If equipped with air conditioning, do *not* operate the heater and air conditioning system with the air source lever in the recirculation mode



**Fig. 3.33, Dash-Face Outlet**

for more than 20 minutes. This will prevent the buildup of fumes or odors inside of the cab (for example, from smoking).

## Defogging and Defrosting

1. Turn the temperature control switch all the way clockwise for warm air, turn the fan switch to off and, if so equipped, move the air conditioning on/off lever to off before starting the engine.
2. Remove any ice or snow from the outside of the windshield, door windows, and fresh air inlet grille.
3. With the engine at operating temperature, turn the fan switch to the highest speed. Leave it in this position for 30 seconds. This will clear the system of moist air.

4. Move the air selection switch to the windshield (defrost) position, turn the air source lever to the fresh air position, and if so equipped, move the air conditioning on/off lever to the on position as shown in [Fig. 3.35](#). In this position, warm, dry air is directed to the windshield.

**IMPORTANT:** If equipped with an air source lever, do *not* operate the heater and air conditioning system with the air source lever in the recirculation mode for more than 20 minutes. This will prevent the buildup of fumes or odors inside of the cab (for example, from smoking).

**NOTE:** At the defrost position, airflow is directed to the windshield outlets, the extreme left and right dash-face outlets, and the door window outlets.

## Heating

1. With the engine at operating temperature, move the temperature control switch all the way clockwise for heat.
2. Turn the fan switch to the highest speed.
3. Move the air selection switch to the desired setting and move the air source lever to the fresh air position as shown in [Fig. 3.36](#).

# Driver Controls and Instruments

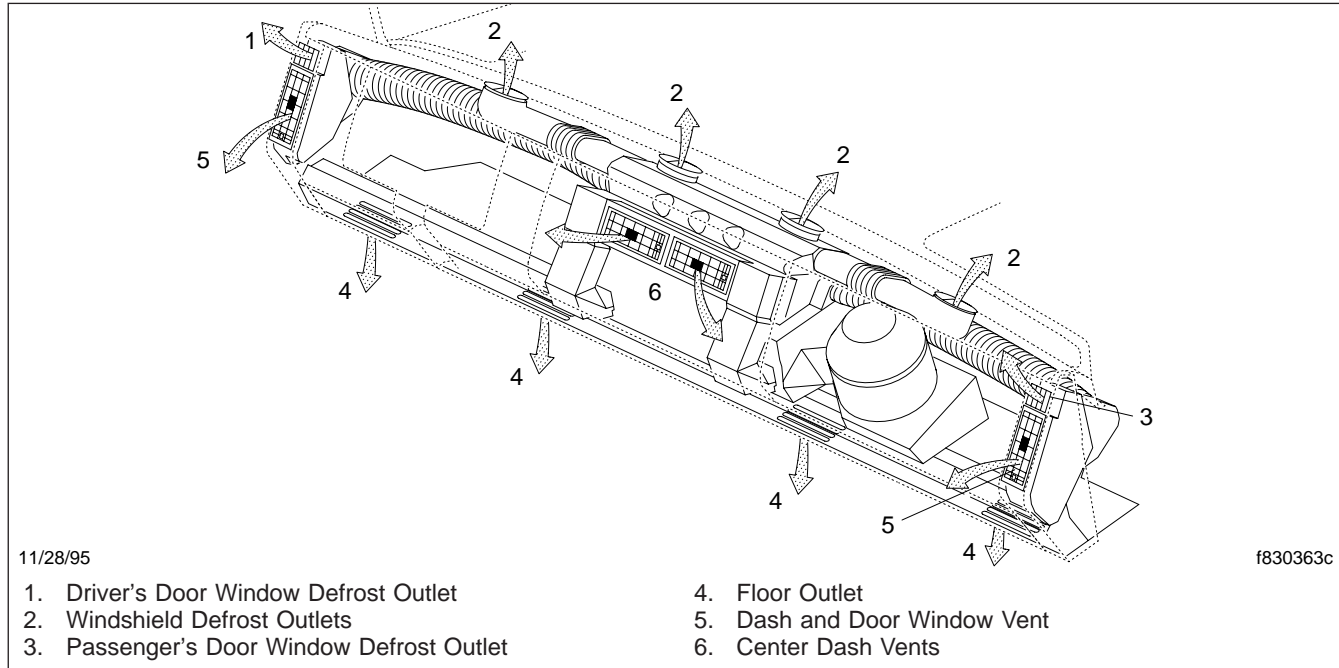
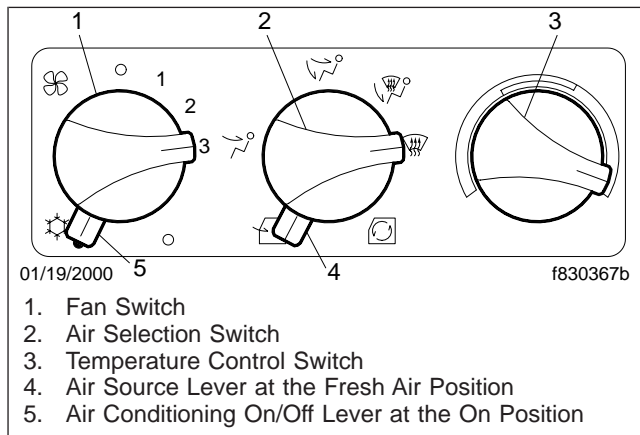

**Fig. 3.34, Air Outlet System**

**IMPORTANT:** If the windows start to fog, move the air selection switch to defrost (windshield) and make sure that the fan is on. To defrost the driv-

er's door window, turn the extreme left dash-face outlet to direct airflow to the upper left.

# Driver Controls and Instruments



**Fig. 3.35, Defogging and Defrosting Settings**

4. When a comfortable temperature has been reached, adjust the fan switch setting and temperature control switch as needed to maintain the temperature.

**IMPORTANT:** If equipped with air conditioning, do *not* operate the heater and air conditioning system with the air source lever in the recirculation mode for more than 20 minutes. This will prevent the buildup of fumes or odors inside of the cab (for example, from smoking).

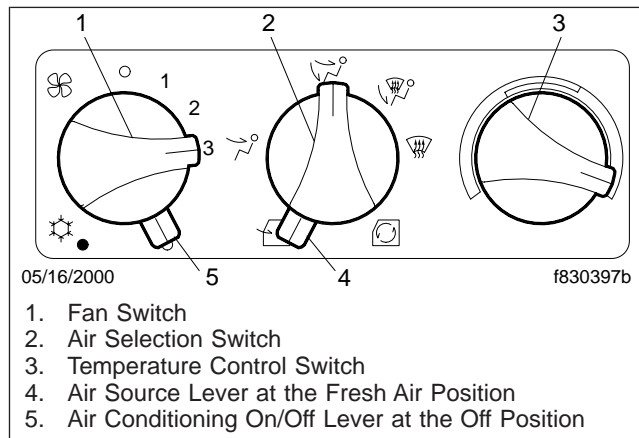

**Fig. 3.36, Heating Settings**

**NOTE:** To increase the flow of warm air to the floor, close the dash-face outlets.

## Air Conditioning Using Fresh Air

**IMPORTANT:** Operate the air conditioner at least five minutes each month, even during cool weather. This helps prevent drying and cracking of tubing seals, reducing refrigerant leaks in the system. Operate the air conditioner only after the engine compartment is warm, and the interior of the



# Driver Controls and Instruments

cab is 70°F (21°C) or higher. During cold weather, the heater can be operated at the same time, to prevent discomfort.

1. If the cab is hot inside, temporarily open the windows to let the hot air out.
2. Move the air conditioning on/off lever to the off position, and turn the fan switch off before starting the engine.
3. Start the engine.
4. Move the air conditioning on/off lever to the on position. Then select fresh or recirculated air with the air source lever.

**IMPORTANT:** If the outside air is dusty or smoky, set the air source lever at recirculated air and keep the windows and vent closed, to prevent drawing in dust or smoke.

5. Move the temperature control switch counterclockwise for cool air. In this position, no heat is given off by the heater.
6. Turn the fan switch to the highest speed. See [Fig. 3.37](#).
7. As soon as cool air is flowing from the dashboard outlets, close the windows. Adjust the fan switch setting as desired.

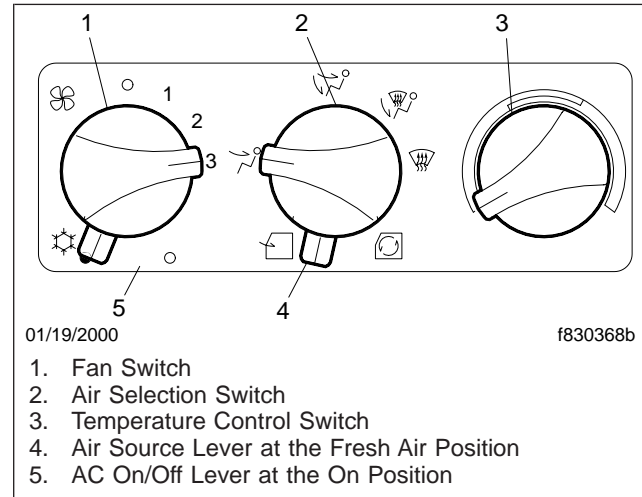

**Fig. 3.37, Air Conditioning Settings**

8. If the air from the vents is too cold, move the temperature control switch clockwise for warmer air flow.

**IMPORTANT:** To prevent the buildup of fumes or odors inside of the cab (for example, from smoking), do *not* operate the heater and air conditioning system with the air source lever in the recirculation mode for more than 20 minutes.

## Fresh Air

1. Move the air source lever (if equipped) to the fresh air position. See [Fig. 3.37](#). Move the air selection switch to the desired position.

NOTE: If not equipped with an air source lever, the air source is fresh air.

2. Move the temperature control switch counterclockwise for no heating, or move it clockwise for heat.
3. Set the fan switch at the desired speed.

IMPORTANT: If equipped with an air source lever, do *not* operate the heater and air conditioning system with the air source lever in the recirculation mode for more than 20 minutes. This will prevent the buildup of fumes or odors inside of the cab (for example, from smoking).

# 4

## Engines

- Engine Starting ..... 4.1
- Cold Weather Starting ..... 4.6
- Starting After Extended Shutdown or Oil Change ..... 4.7
- Engine Break-In ..... 4.7
- Engine Operation ..... 4.8
- Cruise Control ..... 4.16
- Power Takeoff (PTO) Governor ..... 4.18
- Cold Weather Operation ..... 4.19
- High Altitude Operation ..... 4.24
- Engine Shutdown ..... 4.24
- Engine Braking System, Optional ..... 4.27
- Exhaust Braking System, Optional ..... 4.29

# Engines

---

## Engine Starting

NOTE: Before starting the engine, read [Chapter 3](#) for detailed information on how to read the instruments and operate the controls.

Whenever you start an engine, watch for any signs of engine problems. If the engine vibrates, misfires, or makes unusual noises, turn the engine off as soon as possible and determine the cause of the problem. Frequently, engine damage may be avoided by a quick response to early indications of problems.



### CAUTION

**When starting a vehicle equipped with a manual transmission and clutch lock out switch, the clutch pedal must be fully depressed during the entire start sequence. Failure to do so can cause the pinion to release and re-engage, which could cause ring gear and starter pinion damage.**

**If a vehicle does not start on the first attempt, make sure that the engine has completely stopped rotating before reapplying the starter switch. Failure to do so can cause the pinion to release and re-engage, which could cause ring gear and starter pinion damage.**

**Moving a vehicle with the starter and/or using the starter to bump the engine for maintenance procedures is strictly prohibited. Use of these methods to bump the engine over or move the vehicle can cause the pinion to release and re-engage, which could cause ring gear and starter pinion damage.**

IMPORTANT: Ring gear and starter pinion damage caused by improper starting procedures is not warrantable.

## Pre-Start

NOTE: These pre-start steps apply to all engines.

1. Perform the engine pretrip inspection and daily maintenance checks in [Chapter 9](#).
2. Set the parking brake.
3. For manual transmissions, place the transmission in neutral and disengage the clutch.

For automatic transmissions, make sure the transmission shift control is in neutral or park.

NOTE: On vehicles equipped with a neutral start switch, the transmission must be in neutral before the engine can be started. For air start systems, check the air supply before starting the engine. There must be 100 psi (689 kPa) of air pressure available.

## Starting Precautions, All Engines

### **WARNING**

Do not use any starting aid, such as ether, in engines with an intake air preheater. This could cause an explosion and serious personal injury or death.

### **CAUTION**

Don't crank the engine for more than 30 seconds at a time. Wait two minutes after each try to allow the starter to cool. Failure to do so could cause starter damage.

NOTE: Some starters are equipped with optional overcrank protection. If overcranking occurs, a thermostat breaks the electrical circuit to the starter motor until the motor has cooled.

### **CAUTION**

Protect the turbocharger during the start-up by not opening the throttle or accelerating the engine above 1000 rpm until minimum engine idle oil pressure registers on the gauge.

## Mercedes-Benz

NOTE: Before doing these steps, do the steps in "Pre-Start."

### **CAUTION**

Never attempt to start any Mercedes-Benz electronic engine using ether or any other starting fluid. Serious engine damage could result.

1. Turn the ignition switch to the on position ( [Fig. 4.1](#)). All the electronic gauges on the ICU (instrumentation control unit) complete a full sweep of their dials, the warning and indicator lights light up, and the buzzer sounds for three seconds.

**IMPORTANT:** On vehicles equipped with an intake air preheater, the amber INTAKE HEATER indicator stays on for a minimum of two seconds, regardless of coolant temperature. Wait until the INTAKE HEATER indicator goes out before attempting to start the engine.

2. Turn the ignition switch to the start position. Without touching the throttle pedal, start the engine.
3. Idle the engine for one to three minutes at 700 rpm (600 rpm for 6-cylinder engines) before operating the engine under load.

# Engines

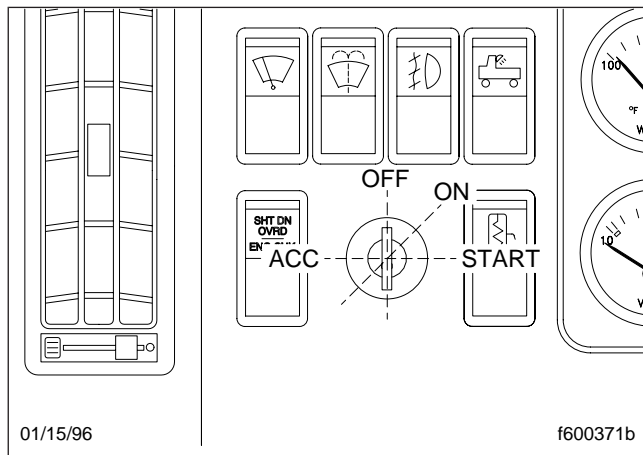

Fig. 4.1, Ignition Switch Positions

4. Check the oil pressure gauge for any drop in lubricating oil pressure or mechanical malfunction in the lubricating oil system. Minimum oil pressure at idle is 7 psi (50 kPa).

## CAUTION

Do not rev the engine if the oil pressure gauge indicates no oil pressure. Shut down the engine if no oil pressure appears within approximately ten seconds. Check to determine the cause of the problem.

Operating the engine with no oil pressure will damage the engine.

## Caterpillar

NOTE: Before doing these steps, do the steps in "Pre-Start."

1. Turn the ignition switch to the on position ( [Fig. 4.1](#)). The amber CHECK ENGINE indicator comes on for five seconds.

IMPORTANT: On vehicles equipped with an intake air preheater, the amber INTAKE HEATER indicator stays on for a minimum of two seconds, regardless of coolant temperature. Wait until the INTAKE HEATER indicator goes out before attempting to start the engine.

2. Turn the ignition switch to the start position. Release the switch the moment the engine starts.
  - 2.1 If the engine does not start after 15 to 20 seconds of cranking, turn the ignition switch off.
  - 2.2 Wait two minutes to allow the starter motor to cool. Turn the ignition switch back to the on position and try to start the engine again.

- 2.3 As soon as the engine starts, release the ignition switch allowing the engine to run at a slow idle.

---

 **CAUTION** 

---

**If the oil pressure is too low, shut down the engine immediately to prevent serious damage. If the vehicle is equipped with an automatic shutdown system, the engine will shut down after 30 seconds.**

3. The engine may be operated at low load and speed once the engine oil pressure has reached 10 psi (69 kPa) and air pressure (if applicable) has reached 64 to 76 psi (441 to 524 kPa).
4. When the engine has reached the minimum operating temperature of 160°F (71°C), the engine may be operated at full load.

## Cummins

---

 **CAUTION** 

---

**Never attempt to start any Cummins IS series electronic engine (ISB, ISC, ISL) using ether or any other starting fluid. Serious engine damage could result.**

**NOTE:** Before doing these steps, do the steps in "Pre-Start."

1. Turn the ignition switch to the on position ( [Fig. 4.1](#)). The amber CHECK ENGINE indicator comes on for five seconds. Leave the ignition switch on until the CHECK ENGINE indicator goes out.

**IMPORTANT:** On vehicles equipped with an intake air preheater, the amber INTAKE HEATER indicator stays on for a minimum of two seconds, regardless of coolant temperature. Wait until the INTAKE HEATER indicator goes out before attempting to start the engine.

2. Turn the ignition switch to the start position. After the engine starts, release the key.
3. Bring the engine up to operating speed gradually as it warms up and develops stable oil pressure.

**NOTE:** When the engine is started, it takes a short time to build up a lubricating oil film between the shafts and bearings, and between the pistons and liners. The oil pressure gauge indicates any drop in lubricating oil pressure within 15 seconds of engine start-up.

# Engines

---

4. If minimum engine oil pressure at idle of 10 psi (69 kPa) does not register within 15 seconds, shut down the engine.



## CAUTION

**Protect the turbocharger during the start-up by not opening the throttle or accelerating the engine above 1000 rpm until minimum engine idle oil pressure registers on the gauge.**

5. Idle the engine for three to five minutes at 1000 rpm before operating the engine under load.

## Detroit Diesel

NOTE: Before doing these steps, do the steps in "Pre-Start."

1. Turn the ignition switch to the on position ( [Fig. 4.1](#)). The CHECK ENGINE and ENGINE PROTECT indicators should come on and go out within six to ten seconds.

**IMPORTANT:** On vehicles equipped with an intake air preheater, the amber INTAKE HEATER indicator stays on for a minimum of two seconds, regardless of coolant temperature. Wait until the INTAKE HEATER indicator goes out before attempting to start the engine.

2. When all the indicators go out, turn the ignition switch to the start position. If the engine won't start within 15 seconds, release the ignition switch and allow the starter motor to cool.

**IMPORTANT:** If the engine won't start, check the main engine power fuses. The fuses are located along the main engine electrical harness on the left frame rail, near the batteries. If the fuses are blown, replace the fuses. Be sure to find the cause of the blown fuses as soon as possible.



## WARNING

**Never pour fuel or other flammable liquid into the air inlet opening in the throttle body in an attempt to start the vehicle. This could result in a flash fire causing serious personal injury or property damage.**

3. Check the oil pressure gauge immediately after starting the engine.
4. If no pressure registers within 10 to 15 seconds or the ENGINE PROTECT indicator comes on, shut down the engine and check the lubricating oil system.



## CAUTION

Protect the turbocharger during the start-up by not opening the throttle or accelerating the engine above 1000 rpm until minimum engine idle oil pressure of 12 psi (83 kPa) registers on the gauge.

5. Idle the engine for about five minutes at 1000 rpm before operating the engine under load.

## Cold Weather Starting

### WARNING

**Do not use any starting aid, such as ether, in engines with an intake air preheater. This could cause an explosion and serious personal injury or death.**

Modern electronic engines do not normally require special starting aids. At low temperatures, intake air preheaters, manifold preheaters, or water jacket heaters are sometimes used to assist in starting.

### Mercedes-Benz

The intake air preheater is activated by turning the ignition switch to the on position (**Fig. 4.1**). If the engine is at normal temperature, the amber INTAKE HEATER indicator goes out after two seconds.

If the temperature is low enough to require the heater, the amber INTAKE HEATER indicator stays on while the intake air preheater warms up. After the indicator goes out, start the engine. If the engine doesn't start after about 30 seconds of cranking, turn the key to the off position and wait two minutes; then repeat the starting procedure.

**NOTE:** If the engine doesn't start on the second try, wait at least five minutes before using the intake air preheater again.

### Caterpillar

Caterpillar truck engines with direct injection are designed to start at temperatures above 32°F (0°C) without using start systems. If the temperature is below 32°F (0°C), startability will be improved by the use of an automatic ether injection system and/or a jacket water heater.

## CAUTION

**Directing ether at the heater element in the intake air preheater could cause extensive engine damage.**

The intake air preheater is activated by turning the ignition switch to the on position (**Fig. 4.1**). If the engine is at normal temperature, the amber INTAKE HEATER indicator goes out after two seconds.

# Engines

---

If the temperature is low enough to require the heater, the INTAKE HEATER indicator stays on while the intake air preheater warms up. After the indicator goes out, start the engine.

**IMPORTANT:** Attempting to start the engine before the INTAKE HEATER indicator has gone off could result in excessive white smoke at startup.

If the engine doesn't start after 15 to 20 seconds of cranking, turn the key to the off position and wait two minutes; then repeat the starting procedure.

## Cummins

The cold start system approved for use on Cummins engines has been based upon starting aid capabilities to  $-25^{\circ}\text{F}$  ( $-32^{\circ}\text{C}$ ).

Turn the ignition switch to the on position (**Fig. 4.1**). If the engine is at normal temperature, the amber INTAKE HEATER indicator goes out after two seconds.

If the temperature is low enough to require the heater, the INTAKE HEATER indicator stays on while the intake air preheater warms up. After the indicator goes out, start the engine.

Run the engine slightly above idle until oil pressure shows on the gauge. If oil pressure doesn't show on the gauge within 30 seconds of starting, turn the key to the

off position and wait one minute; then repeat the starting procedure.

## Starting After Extended Shutdown or Oil Change

Do the following steps after an oil change or after the engine has been shut down for more than three days:

1. Disconnect the electrical connector from the fuel pump solenoid valve.
2. Crank the engine until oil pressure shows on the gauge.
3. Connect the electrical connector to the fuel pump solenoid valve.
4. Start the engine. After one minute, shut down the engine and check for leaks.
5. Allow five minutes for the oil to settle, then check the engine oil level and add oil if needed. Do not overfill.

## Engine Break-In

### Mercedes-Benz

Every Mercedes-Benz engine is tested on a dynamometer before shipment. Therefore, no break-in period is necessary for the MBE900 engine. Before running the

engine for the first time, follow the instructions in *Chapter 2* of the *MBE900 Engine Operator's Manual*.

## Caterpillar

Every Caterpillar engine must pass a full-load operation test on a dynamometer before shipment, eliminating the need for a break-in period. Only an initial operational check is necessary.

## Cummins

Cummins electronic engines are run on a dynamometer before being shipped from the factory. They do not require a break-in period.

**NOTE:** Special break-in oils are not recommended for new or rebuilt Cummins engines.

## Detroit Diesel

Detroit Diesel engines can be put to work upon delivery without having to follow a formal break-in schedule. The engine has been "run-in" on a factory dynamometer during performance and quality assurance tests prior to shipment.

## Engine Operation

### General Information

Operating vehicles with diesel engines in areas where there are concentrated flammable vapors (such as diesel, gasoline, or propane fumes) can create a hazardous situation. These vapors can be drawn into the engine through the air intake, and cause engine overspeed. Be especially cautious of low-lying or closed-in areas, and always check for signs that flammable vapors may be present.



**Don't operate the engine in an area where flammable vapors such as gasoline or diesel fumes are present. Shut down the engine when in an area where flammable liquids or gases are being handled. Failure to observe these precautions could result in serious injury or death.**

All diesel engines have been built to comply with the requirements of the Federal (U.S.) Clean Air Act. Once an engine is placed in service, the responsibility for meeting both state and local regulations is with the owner/operator. Good operating practices, regular maintenance, and correct adjustments are factors which will help to stay within the regulations.

# Engines

---

Adequate maintenance of the engine, which is the responsibility of the owner/operator, is essential to keep the emission levels low.

The driver should be familiar with the vehicle warning system in order to bring the vehicle to a safe stop if the engine malfunctions. If the driver doesn't understand how the warning system works, an engine shutdown could occur causing a safety hazard. See [Chapter 3](#) for information on the control panels for the various engines.

## Mercedes-Benz

While you are driving, watch for any signs of engine problems. If the engine overheats, uses excessive fuel or lubricating oil, vibrates, misfires, makes unusual noises, or shows an unusual loss of power, turn the engine off as soon as possible and determine the cause of the problem. Frequently, engine damage may be avoided by a quick response to early indications of problems.

1. Use the tachometer to determine when to shift. Follow the pattern on the shift lever when moving through the gears.
2. Depending on the vehicle gearing, the posted speed limit can sometimes allow operation in either of the top two gears; however, for improved operating efficiency (fuel economy and engine life), oper-

ate in the top gear at reduced rpm, rather than in the next lower gear at the maximum rpm.

3. Cruise at partial throttle whenever road conditions and speed requirements permit. This driving technique permits operating within the most economical power range of the engine.
4. Use lower gears in steep downhill driving. Normally, the gear used to descend a hill is the same gear used to climb a hill of the same grade.
5. Never allow the engine to exceed the rated speed. Use the exhaust brake and the optional constant-throttle brake, if installed, to lower engine rpm below the rated speed.
6. Never allow the engine to idle for more than 30 minutes. Excessive idling can cause oil to leak from the turbocharger.



## CAUTION

---

**Stop the engine at the first sign of malfunction. Almost all malfunctions give some warning to the operator before significant damage occurs. Many engines are saved because alert operators heed the warning signs (sudden drop in oil pressure, unusual noises, etc.) and immediately shut down the engine.**

NOTE: Long periods of idling are not good for an engine because the combustion chamber temperatures drop so low that the fuel may not burn completely. This will cause carbon to clog the injector spray holes and piston rings, and may result in

stuck valves. If the engine coolant temperature becomes too low, raw fuel will wash the lubricating oil off the cylinder walls and dilute the crankcase oil, causing all moving parts of the engine to suffer from poor lubrication.

## Caterpillar

Proper operation and maintenance are key factors in obtaining the maximum life and economy of a vehicle engine. Follow the directions in the Caterpillar *Operation and Maintenance Manual* and this manual for trouble-free, economical engine operation.

Caterpillar electronic engines can be equipped with a variety of options designed to warn the driver of engine malfunctions. The driver of a vehicle equipped with these engines should know the extent of the warning system in order to bring the vehicle to a safe stop if the engine malfunctions. If the driver doesn't understand how the warning system works, an engine shutdown could cause a safety hazard.

The electronic control system can monitor engine oil pressure, coolant temperature, intake manifold air tem-

perature, and coolant level. There are four customer programmable levels for Caterpillar engine monitoring: off, warning (factory default), derate, and shutdown.

In the engine monitoring off mode the ECM will ignore the oil pressure sensor and coolant level sensor (if installed). Engine monitoring warning mode uses oil pressure, coolant temperature, intake manifold temperature, and the coolant level sensor (if installed and enabled). The CHECK ENGINE indicator will flash and the warning light will come on when the diagnostic code is active. Engine monitoring derate and shutdown modes allow the ECM to alter engine performance or stop the engine to help the engine avoid damage and return to normal conditions.

1. Operate the engine at low load. After minimum oil pressure is reached and the temperature gauge needle begins to move, the engine may be operated at full load.

Caterpillar electronic engines automatically idle at 900 to 1000 rpm for the correct warm-up time after a cold engine start of less than 40°F (5°C). These electronic engine systems will reduce the idle speed to 600 rpm when the engine has warmed sufficiently to operate the vehicle.

# Engines

---

**IMPORTANT:** Fuel heaters used on vehicles with Caterpillar electronic engines could cause excessive fuel temperatures that affect engine performance and operation of the electronic engine controls. If a fuel heater is used, make sure it has thermostatic controls. If the fuel heater has a timer, set the timer to activate only for a limited period of time before the engine starts. Make sure the fuel heater is used only for starting the engine.

2. Select a gear that allows a smooth, easy start without increasing engine speed above low idle or slipping the clutch. Engage the clutch smoothly. Jerky starts waste fuel and put stress on the drivetrain.

It is not necessary to accelerate Caterpillar electronic engines to governed speed in the lower gears to get the vehicle moving, except in a high power demand situation such as starting on a grade.

3. Continue to upshift until cruising speed is reached. Use only the rpm needed to make an upshift into the next gear. The engine speed needed to make an upshift increases as the truck speed increases. If the truck can be operated in a higher gear after reaching the desired speed, select the highest gear available that will pull the load. Experience with your truck will show you what rpm is needed to make upshifts under various conditions. This pro-

gressive shifting technique will lower fuel costs because the engine will be operating at the lowest rpm needed to pull the load.

Caterpillar electronic engines can be programmed to limit engine rpm while the truck is operated in the lower and higher gears. This feature assists the driver in following progressive shifting techniques.

4. On uphill grades, begin downshifting when the engine rpm falls to 1200 rpm. Fuel economy will be best if you let the engine lug back to around this speed before you downshift. Downshift until a gear is reached in which the engine will pull the load. Let the engine lug down if you can make it to the top of a hill without downshifting.

**IMPORTANT:** Do not allow Caterpillar electronic engines to exceed 2300 rpm (2100 rpm if equipped with an exhaust brake).

5. On a downhill grade, do not coast or put the transmission in neutral. Select the correct gear that does not allow the engine to exceed its maximum speed. Use the brakes to limit the truck speed.

A simple rule to follow is to select the same gear (or one gear lower) that would be needed to go up the grade.

6. As with any engine, prolonged idling of Caterpillar engines is not recommended. An idling engine wastes fuel and if left unattended, is also unsafe.

Caterpillar engines can be programmed to shut off automatically after a specified idling time. The vehicle transmission must be in neutral and the parking brake must be set for the automatic shutoff option to work.

## Cummins

Follow the directions in the *Cummins Operation and Maintenance Manual* and in this manual for trouble-free, economical vehicle engine operation.

1. Cummins diesel engines produce high horsepower and peak torque characteristics at low rpm. Because of this, it is not necessary to keep the engine "wound up" to deliver the required horsepower at the wheels. These characteristics may also result in less shifting and make shifting at lower rpm (to peak torque) more practical.
2. Depending on the vehicle gearing, the posted speed limit can sometimes allow operation in either of the top two gears; however, for improved operating efficiency (fuel economy and engine life), operate in the top gear at reduced rpm rather than in the next lower gear at the maximum rpm.
3. Cruise at partial throttle whenever road conditions and speed requirements permit. This driving technique permits operating within the most economical power range of the engine.
4. When approaching a hill, open the throttle smoothly to start the upgrade at full power, then shift down as desired to maintain the optimum vehicle speed. The high torque of Cummins engines may permit topping some grades without shifting.
5. Cummins engines are designed to operate over a wide speed range. More frequent shifting than necessary does not allow proper utilization of this flexibility. The driver who stays in top gear and uses the wider speed range will achieve the best fuel economy.
6. The Cummins diesel engine is effective as a brake on downhill grades, but care must be used not to overspeed the engine going downhill. The governor has no control over engine speed when the engine is being pushed by the loaded vehicle.  
  
Never turn off the ignition switch while going downhill. With the engine still in gear, fuel pressure will build up against the shutdown valve and may prevent it from opening when the ignition key is turned on.

# Engines

---



## CAUTION

**Do not allow the engine to exceed its governed speed, or serious engine damage could result.**

7. Use a combination of brakes and gears to keep the vehicle under control at all times and to keep the engine speed below the rated governed rpm.

## Detroit Diesel

Individual driving habits can make a difference in the performance and economy of any engine. The recommendations below call attention to the techniques that can be employed to save fuel and extend the operating efficiency and life of a new Detroit Diesel engine for the longest possible time.

Engines with Detroit Diesel Electronic Control (DDEC) can be equipped with a variety of options designed to warn the operator of engine problems. The operator of a DDEC-equipped engine should know the extent of the warning system in order to bring the vehicle to a safe stop if the engine malfunctions. If the operator doesn't understand how the system works, an engine shutdown could cause a safety hazard.

All engines have an operating range in which the engine performs most efficiently. The operating range extends from maximum torque rpm at the low end to engine rated speed at the high end. Detroit Diesel engines

deliver best fuel economy when operated in the low- and mid-speed segments of the efficiency range and produce maximum horsepower at rated speed, which is also the recommended maximum speed of the engine.

1. It is seldom necessary to accelerate the engine to governed speed in the lower gears to get the vehicle moving, except in a high power demand situation such as starting on a grade.

To conserve fuel, start off in low gear and develop only the engine speed needed to get rolling. Then, increase engine speed gradually as upward gear shifting progresses.

As described by Detroit Diesel, this progressive shifting technique will get the vehicle up to the desired cruising speed while minimizing noise emission and maximizing fuel economy. A progressive shift pattern is illustrated in [Fig. 4.2](#).

**NOTE:** A momentary hesitation in throttle response will occur when a vehicle with a turbocharged engine is started on a grade. *Do not* disengage the clutch. The rpm will recover and the vehicle will accelerate up the grade.



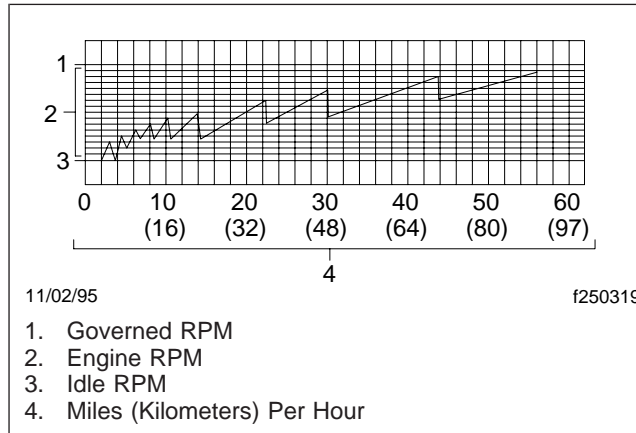

**Fig. 4.2, Progressive Shift Pattern**

2. For city driving, run in the highest gear possible and reduce engine speed. This enables you to operate at a safe speed for traffic conditions while using less fuel and reducing noise. Also, when slowing down for reduced speed zones, remain in your running gear and reduce engine rpm to stay within the speed limit. Avoid downshifting until you are ready to return to highway cruising speed.
3. For highway cruising and for best fuel economy, run the engine at 80 to 90 percent of rated rpm to maintain highway speed. Engines with 1800 rpm ratings are exceptions and will provide fuel

economy when run at their rated speed. Proper gear selection should permit cruising in the economy range with no appreciable sacrifice in desired highway speed.

It is okay to operate below rated rpm at full throttle if you are satisfied with the way the vehicle performs. However, there are times when hilly terrain, high winds, or other conditions make it impractical to operate without reserve power. Such conditions are better met if the vehicle is operated in a lower gear with reserve power available for changes in terrain, wind, etc.

4. The proper use of gears will shorten time on hills and minimize the amount of shifting. When starting up a hill, gradually depress the accelerator pedal all the way down and keep it there as the vehicle moves up the grade. If the engine continues to maintain a satisfactory road speed, remain in that gear for the entire grade.

If the hill causes a steady decline in engine rpm, downshift as required until the engine can maintain a stable uphill speed. Make full use of each gear before going to a lower gear. By remaining in a gear until arriving at the speed of the next lower gear, the vehicle will top the grade in the best possible time on less fuel and fewer shifts.

# Engines

---

5. Because of their constant horsepower over a wide speed range, Detroit Diesel engines can be operated at full throttle at lower rpm than other engines. This offers benefits in fuel economy and engine life. And more than likely, it will be possible to top most grades without downshifting.

When the vehicle starts into a grade, allow the engine to lug down to maximum torque rpm before downshifting. Downshift, if required, at maximum torque rpm also or at the predetermined road speed for the next lower gear.

Do not be afraid to lug the engine down. It has more than enough torque at low rpm to keep a loaded vehicle moving against a grade and it won't harm the engine.

6. The driver who is not familiar with the vehicle's shift points can greatly improve driving skill by learning them for all gears. By knowing rather than guessing where the shift points are, it is possible to avoid overspeeding the engine by downshifting too soon or missing the full use of a gear by downshifting too late. The shift points of any vehicle can be determined by a simple road-test method. Run the vehicle and determine the maximum road speed possible in every gear at the engine governed full-load speed setting.

The top road speed possible in a gear would be the shift point for that gear. The results should be recorded in the proper order of shifting and displayed inside the cab.

7. To slow the vehicle on downgrades and curves (using the engine), shift to a lower gear and allow the vehicle to decelerate in that gear. The engine provides maximum braking effect when running at the top end of the operating range, but it must not be allowed to exceed its full-load rated rpm. Continue to downshift as further reduction in vehicle speed is required. If the vehicle is above the allowable maximum speed of a lower gear, use the service brakes to slow the vehicle to an acceptable speed where the transmission may be downshifted safely. Again, the importance of knowing the shift points is demonstrated.



## CAUTION

---

**Do not allow the engine to exceed its governed speed, or serious engine damage could result.**

**IMPORTANT:** The engine governor has no control over engine rpm when the engine is being pushed by a loaded vehicle down a grade. Use service brakes and gears in combination on long grades to keep the vehicle speed under control and the engine rpm below full-load rated governed speed.

NOTE: Essential information regarding the operation and care of Allison automatic transmissions is contained in the Allison *Driver's Handbook*. Applying the knowledge presented will not only make driving easier, but will give the maximum benefits from an Allison-equipped vehicle. Maintenance literature is also available for drivers of Allison-equipped vehicles who desire trouble-free performance and maximum life from their equipment. These maintenance books are available from any authorized Detroit Diesel engine distributor.

8. As with all engines, prolonged idling of Detroit Diesel engines is not recommended. An idling engine wastes fuel and if left unattended, is also unsafe.

A Detroit Diesel Electronic Control (DDEC) engine can be equipped to shut off automatically after a specified idling time. The vehicle transmission must be in neutral and the parking brake must be set for the automatic shutoff option to work. To start the engine, follow the normal start-up procedure.

Engines equipped with DDEC will idle fast when cold. As the engine warms up to operating temperature, the idle speed will decrease. Warm the engine until idle speed is normal before operating the vehicle.

## Cruise Control

The cruise control is activated by the CRUISE ON and SET/RESUME switches located on the instrument control panel (Fig. 4.3) or by optional PAUSE, RESUME, and SET buttons on the transmission shift knob (Fig. 4.4). The minimum speed at which cruise control can be used on Mercedes-Benz, Caterpillar, and Cummins electronic engines is 30 mph (48 km/h). On Detroit Diesel engines, the minimum speed at which cruise control can be used is 35 mph (56 km/h).

NOTE: On Caterpillar engines, the minimum and maximum speed cruise control set limits can be programmed by authorized personnel into the ECM personality module.

### WARNING

**Do not engage the cruise control in heavy traffic or when road conditions are wet or slippery. Failure to follow this precaution could result in loss of vehicle control and possible property damage or personal injury.**

### CAUTION

**Do not attempt to shift gears without using the clutch pedal when the cruise control is engaged.**

# Engines

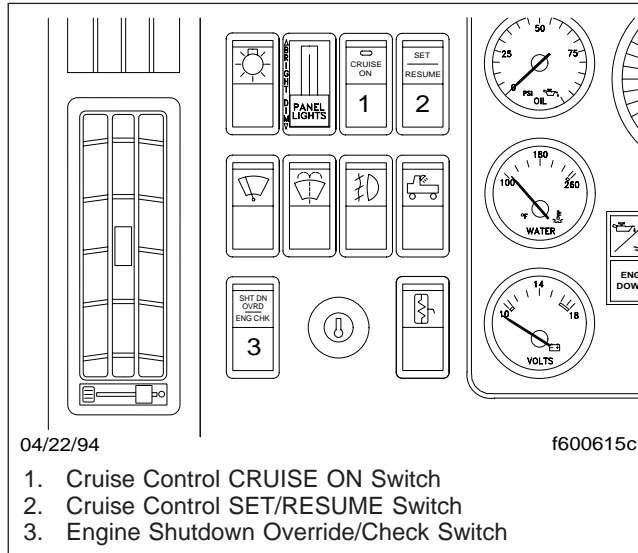

**Fig. 4.3, Cruise Control Switches and Engine Shutdown Override/Check Switch**

**Failure to follow this precaution will result in a temporarily uncontrolled increase in engine speed; transmission damage and gear stripping could result.**

1. To cruise at a particular speed:

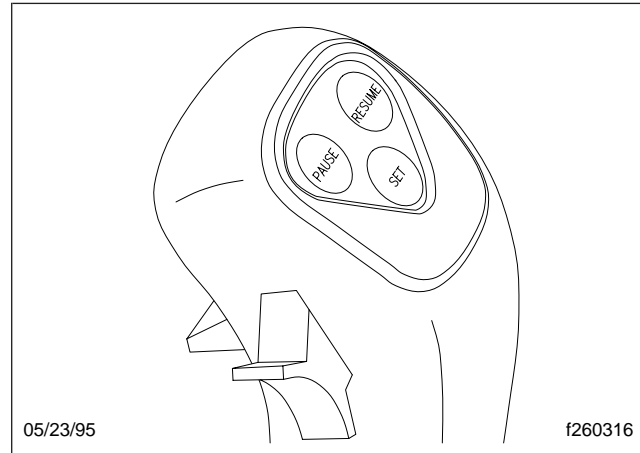

**Fig. 4.4, Cruise Control, Transmission Shift Knob Buttons**

- 1.1 Move the CRUISE ON switch on the instrument panel to on.
  - 1.2 Hold the throttle down until the speedometer indicates the desired speed.
  - 1.3 Momentarily move the SET/RESUME switch on the instrument control panel to SET or push the SET button on the transmission shift knob.
2. To disengage the cruise control:

- 2.1 Depress the brake pedal, or clutch pedal, *or*
  - 2.2 Move the CRUISE ON switch on the instrument control panel to off or push the PAUSE button on the transmission shift knob.
3. To resume a preselected cruise speed:
    - 3.1 If the CRUISE ON switch on the instrument control panel is in the off position, move it to on.
    - 3.2 Momentarily move the SET/RESUME switch on the instrument control panel to RESUME or push the RESUME button on the transmission shift knob. Cruise will return to the last speed selected.

To adjust cruise speed up or down, hold the SET/RESUME switch on the instrument control panel at RESUME to accelerate or at SET to decelerate, or press the RESUME (accelerate) or SET (decelerate) button on the transmission shift knob, until the desired speed is attained.

**NOTE:** The resume vehicle speed memory is not maintained if the ignition is shut off. Also, it is not maintained with Cummins engines if the CRUISE ON switch is turned to off and with Detroit Diesel engines if the CRUISE ON switch is turned to off for more than 10 seconds.

## Power Takeoff (PTO) Governor General Information

All electronic engines may be equipped with a PTO governor. This mode is used only when the vehicle is parked. The PTO mode is activated by the CRUISE ON and SET/RESUME switches on the dash (**Fig. 4.3**) or by optional PAUSE, RESUME, and SET buttons on the transmission shift knob (**Fig. 4.4**).

1. To engage the PTO:
  - 1.1 Move the CRUISE ON switch on the instrument control panel to on.
  - 1.2 Hold the throttle pedal down until the desired engine speed is indicated on the tachometer.
  - 1.3 Momentarily move the SET/RESUME switch on the instrument control panel to SET or push the SET button on the transmission shift knob.

**IMPORTANT:** Two PTO engine speeds can be preset on Cummins CELECT Plus engines. With the CRUISE ON switch in the on position, move the SET/RESUME switch to SET to reach the first preset value or, move the switch to RESUME for the second preset value. After one preset value has been selected, turn the CRUISE ON switch to

# Engines

---

off, then turn it back to on before using the second preset value.

2. To disengage the PTO:
  - 2.1 Depress the brake pedal or clutch pedal, or, (only on Cummins CELECT Plus engines the throttle pedal), *or*
  - 2.2 Move the CRUISE ON switch on the instrument control panel to off or press the PAUSE button on the shift knob.
3. To resume a previously selected engine speed:
  - 3.1 If the CRUISE ON switch on the instrument control panel is in the off position, move it to on.
  - 3.2 Momentarily move the SET/RESUME switch on the instrument control panel to RESUME or press the RESUME button on the transmission shift knob.

To adjust engine speed up or down, hold the SET/RESUME switch on the instrument control panel at RESUME to accelerate or at SET to decelerate until the desired speed is reached, or press the RESUME button on the transmission shift knob to accelerate or the SET button to decelerate until the desired speed is reached.

NOTE: The resume engine speed memory is not maintained if the ignition is shut off or, on Cummins engines, if the CRUISE ON switch is turned to off.

## Detroit Diesel

Some Detroit Diesel engine vehicles have separate controls for the PTO. If equipped with a preset nonadjustable PTO engine speed, there is only an on/off switch labeled FAST IDLE. If the vehicle is equipped with a variable PTO engine speed, there are two controls: an on/off switch, and a potentiometer knob. Both of these are labeled GOVERNOR.

To operate the PTO with separate PTO controls:

1. Apply the parking brakes.
2. Turn on the switch labeled GOVERNOR (or FAST IDLE for vehicles with a preset PTO system).
3. For vehicles with a variable PTO, use the potentiometer knob to adjust the engine rpm.

## Cold Weather Operation

### General Information

Satisfactory performance of a diesel engine operating in low ambient temperatures requires modification of the engine, surrounding equipment, operating practices,

and maintenance procedures. The lower the temperatures the greater the amount of modification required, and yet with the modifications applied, the engines must still be capable of operation in warmer climates without extensive changes.

The following information is provided to engine owners, operators, and maintenance personnel on how the modifications can be applied to get satisfactory performance from their diesel engines.

There are three basic objectives:

- Reasonable starting characteristics followed by practical and dependable warm-up of the engine and equipment.
- A unit or installation which is as independent as possible from external influences.
- Modifications which maintain satisfactory operating temperatures with a minimum increase in maintenance of the equipment and accessories.

If satisfactory engine temperature is not maintained, higher maintenance cost will result due to increased engine wear.

Special provisions to overcome low temperatures are definitely necessary, whereas a change to a warmer climate normally requires only a minimum of revision. Most of the accessories should be designed in such a

way that they can be disconnected so there is little effect on the engine when they are not in use.

**IMPORTANT:** If a winterfront is used on a vehicle with an electronic engine equipped with a charge air cooler, make sure there are vertical slit openings to allow airflow through the core of the charge air cooler. Do not use a winterfront with a diamond-shaped opening, 12 inches by 12 inches (30.5 x 30.5 cm). This will adversely affect the operation and durability of the charge air cooler.

## Mercedes-Benz

Special precautions must be taken during cold weather. For service products to use in cold weather, see **Chapter 5** of the *MBE900 Engine Operator's Manual*.

**IMPORTANT:** At outside temperatures below  $-4^{\circ}\text{F}$  ( $-20^{\circ}\text{C}$ ), a coolant preheater is recommended.

1. Check for cracks in the battery cases, for corrosion of the terminals, and for tightness of the cable clamps at the terminals. Run a load test to determine full or partial charging. Charge the batteries to full capacity. Replace any battery that is unable to hold full charge or is physically damaged.
2. Check the alternator output. Check the condition and tension of the poly-V belt.

# Engines

---

3. Periodically check the coolant mixing ratio (concentration of antifreeze in the coolant). Add more if necessary. The coolant mixing ratio should never rise above 55 percent antifreeze.
4. Use low-viscosity lubricating oils for adequate lubrication.
5. At temperatures below 32°F (0°C), do not use summer-grade (2-D) diesel fuel. To avoid fuel problems due to paraffin separation, use winter-grade (1-D or winterized 2-D) diesel fuel only.



**The addition of kerosene lowers the flash point of diesel fuel. To prevent fire and risk of injuries due to burning, do not smoke or use open flames around fuel mixed with kerosene. Comply with all appropriate safety regulations.**

6. When winter-grade diesel fuel is not adequate, it is possible to mix kerosene with the diesel fuel. Add the kerosene only when refilling the tank, and before adding the diesel fuel.

NOTE: Engine power may drop according to the proportion of kerosene. For this reason, never add more than 50 percent kerosene to the fuel.

## Caterpillar

If the engine is in good mechanical condition and the precautions necessary for cold weather operation are taken, ordinary cold weather will not cause difficulty in starting or loss of efficiency.

If the engine does not start, prime the fuel system.

For cold weather operation, use the following guidelines:

1. When starting the engine in temperatures below 32°F (0°C), use engine lubricants of lower viscosity. See the engine operation and maintenance manual for specifications.
2. When operating in temperatures below 32°F (0°C), use sufficient antifreeze solution in the cooling system to prevent freezing.
3. During cold weather, give more attention to the condition of the batteries. Test them frequently to ensure sufficient power for starting. Inspect all switches and connections in the electrical system and keep them in good condition to prevent losses through poor contacts. See **Group 15** in the *Business Class® Trucks Service Manual* for detailed information.
4. If so equipped, turn off the battery disconnect switch after the engine is stopped to prevent battery discharge while the starter motor is cooling.



For starting below 0°F (−18°C), an optional cold-weather starting assist is recommended. For temperatures below −10°F (−23°C), consult your Caterpillar dealer for recommendations.



**Do not use any starting aid, such as ether, in engines with an intake air preheater. This could cause an explosion and serious personal injury or death.**

5. Customer parameters may include cold mode operation. When the coolant temperature is below 64°F (18°C), the system puts the engine in cold mode, limiting engine power, advancing timing, and adjusting the low idle to 600 rpm to improve warm-up time. The system will keep the engine in cold mode until coolant temperature rises above 64°F (18°C) or until the engine has been running for 12 minutes. The system will then stop the cold mode and allow the engine to operate normally.
6. Fuel cloud point is the temperature at which wax crystals become visible, which is generally above the pour point of the fuel. To keep the fuel filter elements from plugging with wax crystals, the cloud point should be no higher than the lowest ambient temperature at which the engine must start.

## Cummins

The two most commonly used terms associated with preparation of equipment for low-temperature operation are "winterization" and "arctic specifications."

Winterization of the engine and/or components so that starting and operating are possible in the lowest temperature to be encountered, requires:

- Proper lubrication with low-temperature lubricating oils.
- Protection from the low-temperature air. The metal temperature does not change, but the rate of heat dissipation is affected.
- Fuel of the proper grade for the lowest temperature.
- Heat to raise the engine block and component temperatures to at least −25°F (−32°C) for starting in lower temperatures.
- Electrical equipment capable of operating in the lowest expected temperature. All switches, connections, and batteries in the electrical system should be inspected and kept in good condition to prevent losses through poor contacts.

Arctic specifications refer to the design of material and specifications of components necessary for satisfactory engine operation in extremely low

# Engines

---

temperatures to  $-64^{\circ}\text{F}$  ( $-53^{\circ}\text{C}$ ). Contact the nearest Freightliner dealer or Cummins engine dealer, to obtain the special items required.



## CAUTION

**"Antileak" antifreezes are not recommended for use in Cummins engines. Although these antifreezes are chemically compatible with DCA water treatment, the "antileak" agents may clog the coolant filters.**

IMPORTANT: Fuel heaters used on vehicles with Cummins CELECT engine systems could cause high fuel temperatures that affect engine performance and operation of the electronic engine controls. If a fuel heater is used, make sure it has thermostatic controls. If the fuel heater has a timer, set the timer to activate only for a limited period of time before the engine starts. Make sure the fuel heater is used only for starting the engine.

## Detroit Diesel

Preparations made in advance of winter and maintenance performed during the cold months will help to ensure efficient engine starting and operation.

1. Engine oil thickens as it gets colder, slowing cranking speed. When cold, multigrade oil offers less resistance to the cranking effort of the engine and

permits sufficient rpm to be developed to start the engine. See "Lubricating Oil Recommendations" in the Detroit Diesel *Owner's and Operator's Guide* for specific recommendations.

2. When an engine equipped with a DDEC system is started at temperatures below  $25^{\circ}\text{F}$  ( $-4^{\circ}\text{C}$ ), the idle speed automatically increases to 900 rpm. The injection timing is also advanced to decrease white smoke. As the engine oil warms up, the idle speed gradually decreases. When the oil temperature reaches  $122^{\circ}\text{F}$  ( $50^{\circ}\text{C}$ ), both the idle speed and the injection timing return to normal.
3. During cold weather, the batteries should be tested more frequently to ensure ample power for starting. All electrical connections should be tight and in good condition to prevent losses through loose or corroded connections.
4. The ether start system should be properly charged and in good working order.
5. Ethylene glycol base antifreeze is recommended. An inhibitor system is included in this type of antifreeze, and the corrosion protection is sufficient as long as the recommended concentration range of 30 to 67 percent (antifreeze to water by volume) is employed.
6. If the engine is to be operated in arctic temperatures, consult the nearest Freightliner dealer or an

authorized Detroit Diesel engine dealer for information regarding availability of special cold-weather equipment.

## High Altitude Operation

Engines lose horsepower when operated at high altitude because the air is too thin to burn as much fuel as at sea level. This loss is about three percent for each 1000 feet (300 m) altitude above sea level for a naturally aspirated engine. Most turbocharged engines are rated for higher altitudes than naturally aspirated engines.

An engine will have smoky exhaust at high altitudes unless a lower gear is used. The engine will not demand full fuel from the fuel system unless the engine is altitude-compensated by the use of a turbocharger. Shift gears as needed to avoid excessive exhaust smoke.

## Engine Shutdown

### Mercedes-Benz

If any of the following occur, shut down the engine immediately.

- The oil pressure swings back and forth or falls sharply.
- Engine power and rpm fall even though the accelerator pedal remains steady.

- The exhaust pipe gives off heavy smoke.
- The coolant and/or oil temperature climb abnormally.
- Abnormal sounds suddenly occur in the engine or turbocharger.

1. With the vehicle stopped, apply the parking brakes and place the transmission in neutral.



### CAUTION

**After hard operation, shutting down the engine without idling may cause damage to the turbocharger.**

2. Allow the engine to idle one to two minutes before shutting it down. This allows the lubricating oil and the coolant to carry heat away from the combustion chambers, bearings, shafts, and seals. The extreme heat may cause bearings to seize or oil seals to leak.

**IMPORTANT:** Bearings and seals in the turbocharger are subjected to the high heat of combustion exhaust gases. While the engine is running, this heat is carried away by oil circulation, but if the engine is stopped suddenly, the turbocharger temperature may rise as much as 115°F (46°C).

# Engines

---



## CAUTION

**Except in emergency, do not shut down the MBE900 engine when the coolant temperature is above 194°F (90°C). To do so could damage the engine.**

3. Turn off the ignition switch and shut down the engine.

## Caterpillar



## CAUTION

**Stopping the engine immediately after it has been working under load can result in overheating and accelerated wear of the engine components. Excessive temperatures in the turbocharger center housing will cause oil coking problems. Follow the procedure outlined below to allow the engine to cool.**

1. With the vehicle stopped, apply the parking brakes.
2. Reduce the engine speed to low idle.
3. Place the transmission shift lever in neutral.

**NOTE:** If the engine has been operating at low loads, run it at low idle for 30 seconds before stopping. If the engine has been operating at high-speed or at high loads, run it at low idle for

three minutes to reduce and stabilize internal engine temperatures before stopping.

4. Check the crankcase oil level while the engine is stopped. Maintain the oil level between the add and full marks on the dipstick.
5. Turn off the ignition switch and shut down the engine.
6. If equipped with an idle shutdown timer, it can be set to shut the engine down after a preset amount of time. Ninety seconds before the preset shutdown time, the CHECK ENGINE indicator will begin to flash at a rapid rate. If the position of the clutch pedal or service brake changes during this final ninety seconds (diagnostic light flashing) the idle shutdown timer will be disabled until reset.
7. After stopping the engine, fill the fuel tank.
8. If temperatures below 32°F (0°C) are expected, allow the engine water jacket expansion tank to cool, then check the coolant for proper antifreeze protection. The cooling system must be protected against freezing to the lowest expected outside temperature. Add permanent-type antifreeze if required.
9. Repair any leaks, perform minor adjustments, tighten loose bolts, etc. Observe the vehicle mileage or the service meter reading, if so equipped. Perform periodic maintenance as instructed in the

Lubrication and Maintenance Chart in the Caterpillar *Operation and Maintenance Management*.

## Cummins

1. With the vehicle stopped, apply the parking brakes and place the transmission in neutral.
2. Idle the engine three to five minutes before shutting it down. This allows the lubricating oil and the water to carry heat away from the combustion chambers, bearings, shafts, etc. This is especially important with turbocharged engines.

Bearings and seals in the turbocharger are subjected to the high heat of combustion exhaust gases. While the engine is running, this heat is carried away by oil circulation, but if the engine is stopped suddenly, the turbocharger temperature may rise as much 115°F (46°C). The extreme heat may cause bearings to seize or oil seals to leak.

3. Do not idle the engine for excessively long periods. Long periods of idling are not good for an engine because the combustion chamber temperatures drop so low the fuel may not burn completely. This will cause carbon to clog the injector spray holes and piston rings and may result in stuck valves.

If the engine coolant temperature becomes too low, raw fuel will wash the lubricating oil off the cylinder walls and dilute the crankcase oil; therefore, all

moving parts of the engine will suffer from poor lubrication.

4. Turn off the ignition switch and shut down the engine.



## CAUTION

**Stop the engine at the first sign of malfunction. Almost all malfunctions give some warning to the operator before significant damage occurs. Many engines are saved because alert operators heed warning signs (sudden drop in oil pressure, unusual noises, etc.) and immediately shut down the engine.**

## Detroit Diesel

1. With the vehicle stopped, apply the parking brakes and place the transmission in neutral.
2. Allow the engine to run at half speed or slower with no load for four to five minutes to cool the engine gradually and uniformly.
3. Turn off the ignition switch and shut down the engine.

# Engines

---

## Engine Braking System, Optional

### Constant-Throttle Valves (MBE900 only)

To increase braking performance, the Mercedes-Benz MBE900 engine can be equipped with constant throttles in each combustion chamber. Small valves built into the cylinder head allow a small amount of compressed air to escape through the exhaust port during the combustion stroke. The constant-throttle valves are open during the entire time that the engine brake is activated. Although some braking ability is lost because the valves are constantly open, constant-throttle braking is quieter in operation than other types of engine brakes.

When only the exhaust brake is installed, a two-position switch on the dash controls the engine braking system. The exhaust brake is only active when the engine speed is between 900 and 2,700 rpm. Depressing the accelerator or clutch pedal deactivates the exhaust brake. The ABS system, when active, also deactivates the exhaust brake.

When both the exhaust brake and the constant throttles are installed, a three-position switch on the dash controls the engine braking system. The exhaust brake can be used alone or together with constant-throttle valves for steep or long grades. Like the engine brake, the

constant throttles are deactivated when the accelerator or clutch pedal is depressed. The ABS system, when active, also deactivates constant-throttle braking.

### Jacobs Engine Brake

A Jacobs engine brake is a hydraulic-electric engine attachment that converts a diesel engine into an air compressor. This is done by changing engine exhaust valve operation. An engine brake is not a substitute for a service braking system, except in emergencies, because it does not provide the precise control available from the service brakes.

The Jake Brake is controlled by a single, dash-mounted paddle switch with three positions: OFF, LO and HI.

### Jacobs Engine Brake Operation



**Don't use the engine brake if road surfaces are slippery. Using the engine brake on wet, icy, or snow-covered roads could result in loss of vehicle control, possibly causing personal injury and property damage.**

To engage the engine brake, the dash switch must be in the LO or HI position and both the clutch and throttle pedals must be fully released. To disengage the engine

brake, depress the throttle or clutch pedal, or move the dash switch to OFF.



**The engine brake must be disengaged when shifting gears. The clutch must be used if the dash switch is in the LO or HI position. If the engine brake is engaged when the transmission is in neutral, the braking power of the engine brake can stall the engine, which could result in loss of vehicle control, possibly causing personal injury and property damage.**

Since the engine brake is most effective at rated engine speed, gear selection is very important. Gearing down the vehicle within the limits of the rated engine speed makes the engine brake more effective. Maximum braking occurs with the use of the lowest gear that does not exceed the rated engine speed. A rule of thumb for gear choice is to select the gear that normally would be used to climb an approaching downhill grade. Generally, this same gear can be used with the engine brake for a controlled descent of the hill.

"Control speed" is the speed at which the engine brake performs 100 percent of the required downhill braking, resulting in a constant speed of descent. The control speed varies depending on vehicle weight and the downhill grade.

For faster descent, select a higher gear than that used for control speed. Service brakes must then be used intermittently to prevent engine overspeed and to maintain desired vehicle speed.

**IMPORTANT:** When descending a grade, remember that frequent use of service brakes causes them to become hot, which results in a reduction of their stopping ability. Grade descent speed should be such that the service brakes are used infrequently and that they remain cool, thus retaining their effectiveness.

A driver may descend slower than control speed by selecting a lower gear, one that will not overspeed the engine. The engine brake retarding force will then be sufficient to cause vehicle deceleration. Occasional deactivation of the engine brake may be necessary to maintain the designated road speed under these conditions.

The engine brake can be used to stop a vehicle if the service brakes quit working. By energizing the engine brake as soon as a service brake problem is apparent, a retarding effect is applied to the vehicle. As grade conditions permit, the driver can progressively downshift, using the engine brake in each gear. Eventually, the engine brake will stop the vehicle.

# Engines

---

## **WARNING**

**Don't use the engine brake as a primary braking system when the service brakes are operable. This can cause long, unpredictable stopping distances, possibly resulting in personal injury or property damage.**

Whenever vehicle braking is required, the engine brake may be used with the service brakes. There is no time limit for operation of the engine brake.

1. After the engine is warmed up and the vehicle is in motion, move the paddle switch to the desired position, LO or HI. Depending on the engine model, LO will provide 1/3 or 1/2 of the full braking capacity of the engine. HI will provide maximum engine braking.
2. The engine brake activates when the dash switch is in LO or HI position and the driver's feet are removed from both the clutch and throttle pedals. If the engine brake fails to activate, stop the vehicle in a safe spot and check the adjustment of the throttle and clutch switches. If no cause can be detected in the electrical system, check the engine brake system.
3. To obtain maximum retarding, maintain the top governed speed of the engine through appropriate selection of gears when the engine brake is in use.

4. When either the clutch or throttle pedal is depressed, the engine brake is deactivated.

## **CAUTION**

**If the engine brake fails to shut off when either the throttle or clutch pedal is depressed, place the dash switch in the OFF position and do not use the engine brake until the throttle or clutch switch system is repaired. If the engine brake fails to shut off when the dash switch is turned off, the engine should be shut down and the engine brake repaired before continuing operation. Failure to do so could result in damage to the engine.**

## **Exhaust Braking System, Optional**

### **General Information**

An exhaust brake is an optional auxiliary braking system that assists but does not replace the service brake system. The exhaust brake switch located on the control panel, in combination with the accelerator and clutch pedals, allows the driver to make maximum use of the exhaust brake in off-highway and mountain driving as well as in traffic or high speed highway driving.



The exhaust brake is a butterfly type valve mounted in the exhaust pipe. When the driver's foot is not on the accelerator pedal and the exhaust brake switch is in the on position, an air cylinder shuts the butterfly valve which restricts the flow of exhaust gases and retards the engine. This retarding action is carried through the engine and drivetrain, slowing the vehicle and reducing the need for frequent service brake applications.

Exhaust brakes are not intended for use as the primary braking system during vehicle operation.

## Starting the Engine

Before starting the engine, make sure that the exhaust brake switch is in the off position. Do not turn the exhaust brake on until the engine has reached normal operating temperatures.

## Driving Downhill

While approaching a steep grade, make sure that the exhaust brake switch is in the on position. The exhaust brake comes on as soon as you remove your foot from the accelerator pedal. While going down the grade, use a low enough gear to safely descend with a minimum application of the service brakes. As a general guideline, use the same gear as you would to ascend the hill.

## CAUTION

**Do not allow the engine to exceed its governed speed or serious engine damage could result.**

Apply the service brakes to reduce the engine rpm or make a slower descent by using a lower gear.

## WARNING

**Do not use the exhaust brake when driving on slippery or low traction road surfaces. Failure to follow this precaution could result in a loss of vehicle control and possible personal injury or property damage.**

## Exhaust Brake Operating Characteristics

When you remove your feet from both the accelerator and clutch pedals and the exhaust brake switch is in the on position, the exhaust brake is applied. The following conditions should exist if the brake is operating properly:

- A slight change in the sound of the engine may be noticed when the exhaust brake is applied.
- Exhaust smoke should appear normal.
- Engine temperature should remain in the normal operating range.

# Engines

---

- Road speed usually decreases when the exhaust brake is applied during a descent. When the vehicle is carrying a heavy load or the grade is extremely steep, you may need to apply the service brakes occasionally.
- Do not expect a retarding effect similar to sudden hard application of the service brakes. The exhaust brake retards the vehicle with a smooth braking effect.
- During a descent, the tachometer usually shows a drop in rpm depending on the grade and the vehicle load.
- Depending on the grade and vehicle load, you may or may not feel the retarding force acting against your body when the brake is applied. The retarding force of the brake may not always be noticed, but it is actually preventing the vehicle from going much faster.

## Shutting Off the Engine

Make sure the exhaust brake is turned off before shutting off the engine.

## Pacbrake<sup>®</sup> Exhaust Brake

The Pacbrake exhaust brake is intended as a supplement to the service brakes and will *not* bring the vehicle to a complete stop. The Pacbrake will assist in the control or reduction of road speed in conjunction with, or

independent of, the service brakes. The amount of retarding or braking force is controlled by the driver.

## Pacbrake Operation

The Pacbrake is controlled by the exhaust brake switch and the throttle pedal. All applications are additionally affected, controlled, or governed by engine speed through transmission gear selection. The Allison MD3060 transmission has automatic downshifting when the exhaust brake is requested. See the information on the "Allison World Transmission" later in this chapter.

On some applications, when the Pacbrake is in use, it may be necessary to check that the cruise control is not set and that the throttle is in the idle position.

On some applications the engine, transmission, cruise control, and the Pacbrake exhaust brake may electronically interact with each other, which automatically operates their functions. Following are some examples of the programmed options that may be available with the cruise control in the on position:

- The coast mode engages the Pacbrake when the service brake is applied and disengages when the service brake is released.
- The latch mode engages the Pacbrake when the service brake is applied and the Pacbrake remains on after the service brake is released. The Pacbrake is disengaged when another input (depressing the throttle or clutch, engine speed

drops below 800 rpm, or the exhaust brake switch is turned off) is supplied.

- The manual mode does not require the cruise control switch to be on and operates the Pacbrake manually at the driver's discretion.

The amount of braking power the engine will develop is related to the speed (rpm) of the engine. The higher the engine rpm, the greater the retarding power.

Certain conditions may require that the transmission be downshifted in order to generate adequate rpm for the amount of retarding power required. Pacbrake exhaust brakes are designed and approved for safe use at 300 rpm above the engine's maximum governed rpm. Refer to individual engine manufacturer's specifications.

The Pacbrake will function best if it is used all of the time. However, if the vehicle is used inconsistently or seasonally, it may be necessary to perform a preventive maintenance procedure.

1. With the engine shut-down, use any oil-free or non-petroleum based high-heat lubricant and spray or coat a sufficient amount on the restricter valve shaft and the attaching locations at each end of the actuation cylinder. See [Fig. 4.5](#).
2. With your hands or a pair of pliers, motion the valve several times to distribute the lubricant down the shaft and the attaching locations.

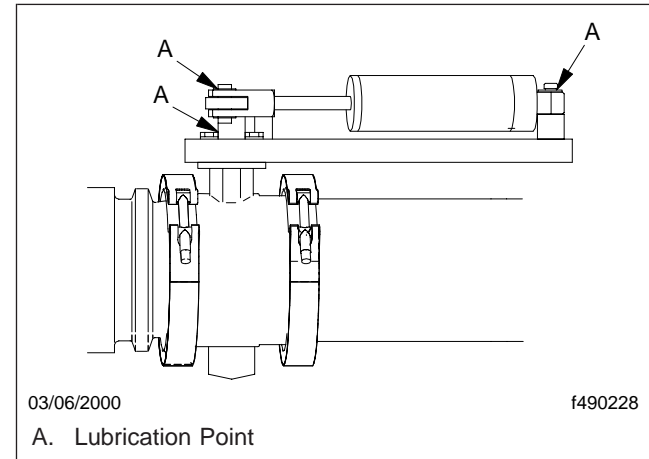

**Fig. 4.5, Pacbrake Exhaust Brake and Air Cylinder**

**NOTE:** Starting the engine and idling for short periods of time is not recommended. During a cold engine start-up, enough moisture is developed within the engine and the exhaust system to create a corrosion hazard that could affect the future operation of the Pacbrake. The brake housing may trap water in the valve shaft bore causing corrosion in an improper or nonfunctioning brake. If it is

# Engines

---

necessary to periodically start the engine, it is recommended that normal operating temperatures be attained before shutting down the engine.

## **Allison World Transmission**

Pacbrake exhaust brakes on engines that are used with the Allison World Transmission MD series, are interfaced with the transmission electronic control module (ECM). An exhaust brake enabled transmission ECM will usually provide converter lockup in gears two through six. Effective exhaust braking begins when the transmission automatically downshifts into fifth gear (62 mph or less). Once on, the Pacbrake exhaust brake will control road speed and/or slow the vehicle sufficiently that the transmission will automatically downshift, if necessary, to Allison's preselect mode.

The preselect mode is normally assigned to second gear; however, the transmission can be reprogrammed by an Allison Transmission Distributor to third or fourth gear should the operator desire. If additional retarding power is required before the automatic downshifting occurs, you can select a lower transmission gear on the Allison shift selector.

## Transmissions

Eaton® Fuller® Straight-Shift Transmissions .....	5.1
Eaton Fuller Range-Shift Transmissions .....	5.2
Eaton Fuller Super 10 Models .....	5.10
Eaton Fuller AutoSelect Automated Transmissions .....	5.14
Eaton Fuller AutoShift™ .....	5.18
Meritor Range-Shift Models .....	5.21
Meritor Splitter and Range-Shift Models .....	5.25
Mercedes-Benz Manual Transmissions .....	5.28
Allison Automatic Transmissions .....	5.29
Chrysler Automatic Transmissions .....	5.36
Aisin A581 Automatic Transmission .....	5.39

# Transmissions

## Eaton® Fuller® Straight-Shift Transmissions

Refer to the Eaton web site for additional information, [www.roadranger.com](http://www.roadranger.com). A connection to the Internet is required.

### General Information, Straight-Shift

Eaton Fuller 5-speed FS models are fully synchronized. They have five forward speeds and one reverse. See [Fig. 5.1](#) for the shift pattern.

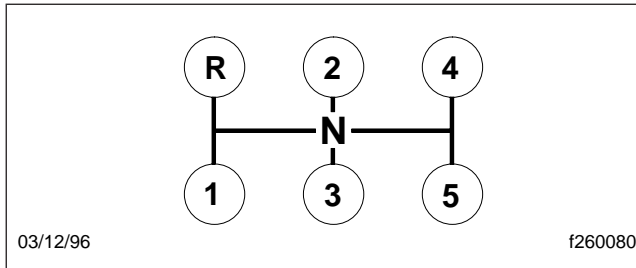

**Fig. 5.1, Shift Pattern, 5-Speed FS Models**

Eaton Fuller 6-speed FS models are fully synchronized. They have six forward speeds and one reverse. See [Fig. 5.2](#) for the shift pattern.

Eaton Fuller 7-speed T models are not synchronized. They have seven forward speeds and one reverse. See

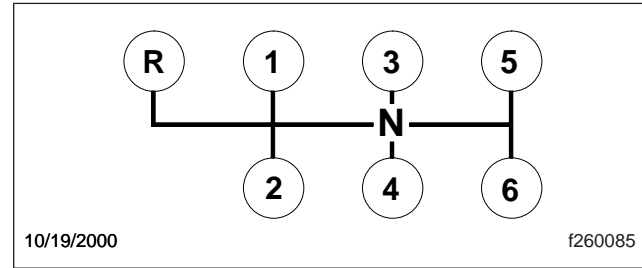

**Fig. 5.2, Shift Pattern, 6-Speed FS and FSO Models**

[Fig. 5.3](#) for the shift pattern. These models are not synchronized; always double-clutch when shifting.

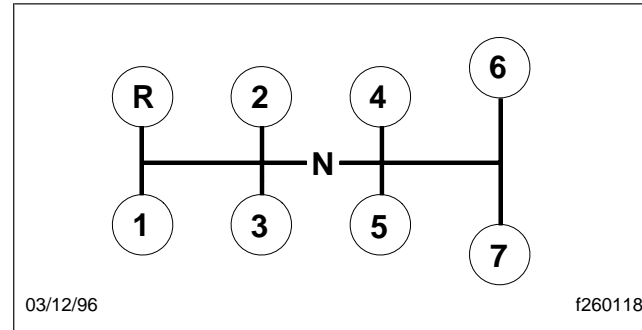

**Fig. 5.3, Shift Pattern, 7-Speed T Models**

These transmissions are designed for use with on-highway, fuel economy engines, where a minimum of shifting is desired and less gear reduction is acceptable.

## Operation, Straight-Shift

1. Always use 1st gear when starting to move the vehicle forward.
2. Accelerate to engine governed speed. Disengage the clutch and move the shift lever to 2nd gear; double-clutch with the seven-speed models. Engage the clutch and accelerate to engine governed speed.

**IMPORTANT:** Do not rest your foot on the clutch pedal while driving. This causes partial clutch disengagement, which could cause premature clutch wear.

3. Continue upshifting using the same sequence described in step 2 above. Follow the pattern on the shift lever.
4. When downshifting, shift progressively down through each successive lower gear as follows:

When the engine speed drops to the same rpm to which it fell immediately after upshifting to that same gear, disengage the clutch and move the shift lever to the next lower gear. Engage the clutch smoothly.

Continue downshifting, as conditions require, using the same sequence described above.

**NOTE:** With synchronized models (five-speed and six-speed) disengage the clutch completely when shifting gears. Double clutching is unnecessary. With nonsynchronized models (seven-speed) always double-clutch when shifting gears. If the vehicle is moving when shifting, depress the clutch pedal just far enough to disengage the clutch. Depressing it to the floor will engage the clutch brake, if so equipped, causing premature clutch brake wear.

## Eaton Fuller Range-Shift Transmissions

Refer to the Eaton web site for additional information, [www.roadranger.com](http://www.roadranger.com). A connection to the Internet is required.

## General Information, Eaton Range-Shift

**IMPORTANT:** These are nonsynchronized transmissions. Always double-clutch when shifting

# Transmissions

gears. If the vehicle is moving when shifting, depress the clutch pedal just far enough to disengage the clutch. Pressing it to the floor will engage the clutch brake, if so equipped, causing premature clutch brake wear.

Eaton Fuller 9-speed range-shift models are not synchronized. They have nine forward speeds and two reverse speeds. The shift lever controls five forward gears and one reverse gear in the transmission front section, and the range lever controls a LO and HI range in the two-speed auxiliary section. The first position in the front section is used only as a starting gear. The other four ratios are used once in LO range and once again in HI range. See [Fig. 5.4](#) for the shift pattern.

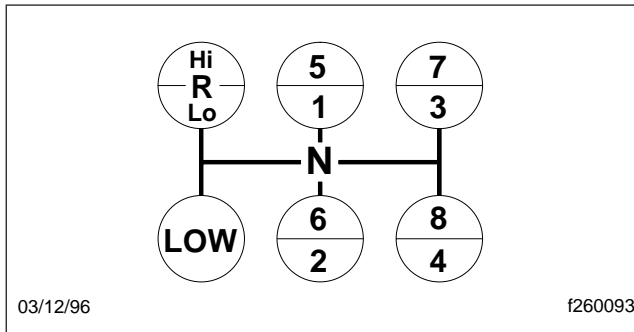

**Fig. 5.4, Shift Pattern, 9-Speed Range-Shift Models**

Eaton Fuller 10-speed range-shift models are not synchronized. They have ten forward speeds and two reverse speeds. The shift lever controls five forward gears and one reverse gear in the transmission front section, and the range lever controls a LO and HI range in the two-speed auxiliary section. The five forward gears selected in LO range are used again in HI range to provide the 10 progressive forward gears. See [Fig. 5.5](#) for the direct-drive shift pattern or [Fig. 5.6](#) for the overdrive pattern.

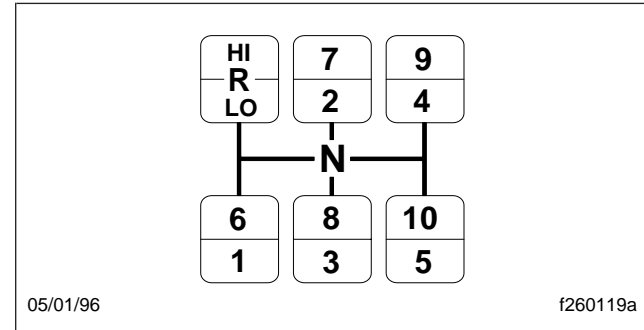

**Fig. 5.5, Shift Pattern, 10-Speed (direct-drive models)**

Eaton Fuller 13-speed range-shift models are not synchronized. They have thirteen forward speeds and two reverse speeds. Each transmission consists of a 5-speed front section, and a 3-speed auxiliary section. The auxiliary section contains LO- and HI-range ratios,



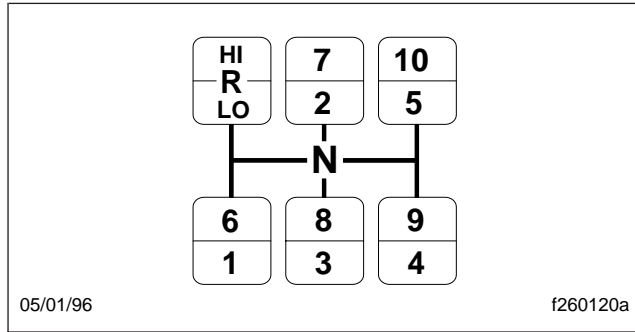
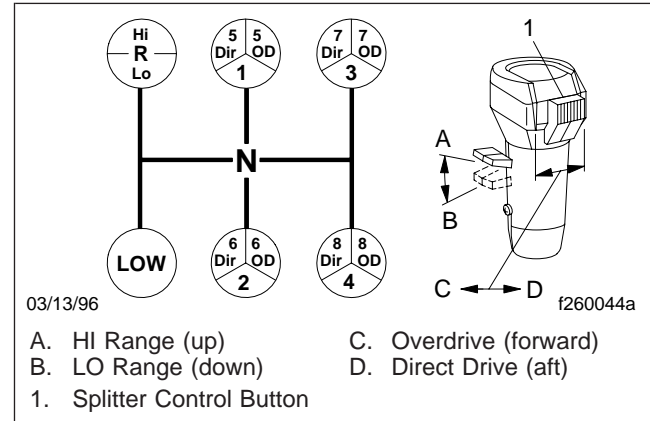

**Fig. 5.6, Shift Pattern, 10-Speed (overdrive models)**

plus an overdrive splitter gear. See [Fig. 5.7](#) for the shift pattern.

All of the thirteen speeds are controlled with one shift lever. Built into the shift knob are a range preselection lever and a splitter control button (on the side of the shift knob). These control range selection and gear splits, respectively.

Eaton Fuller deep-reduction models are not synchronized. They have a five-speed front section and a two-speed auxiliary section which has an extra deep reduction gear. The LO gear in the front section is used only as a starting gear. The other four ratios are used once in LO range and once in HI range giving eight highway ratios. LO-LO is selected by the deep-reduction lever on the dashboard. See [Fig. 5.8](#) for the shift pattern.



**Fig. 5.7, Shift Pattern, 13-Speed Models**

## Operation, All Eaton Range-Shift Models

1. When operating off-highway, or under adverse conditions, always use low gear when starting to move the vehicle.

For all conditions, use the highest gear that is still low enough to start the vehicle moving with the engine idling, and without slipping the clutch excessively.

# Transmissions

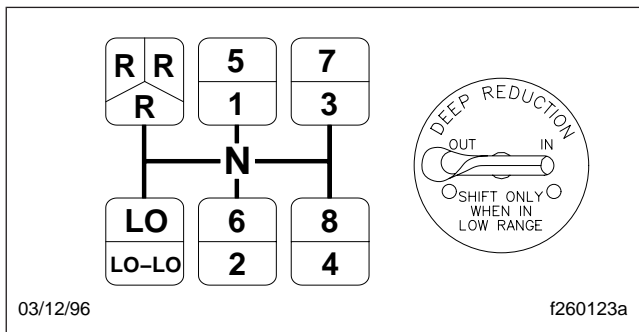

Fig. 5.8, Shift Pattern, Deep Reduction

## CAUTION

**Never use the clutch brake when downshifting, or as a brake to slow the vehicle. This will cause premature clutch brake wear.**

2. Use the clutch brake to stop gear rotation when shifting into low (or 1st) or reverse when the vehicle is stationary. The clutch brake is applied by depressing the clutch pedal all the way to the floor.

For normal upshifts and downshifts, only a partial disengagement of the clutch is necessary to break engine torque.

3. Do not make range shifts with the vehicle moving in reverse gear.
4. Never attempt to move the range preselection lever with the gear shift lever in neutral while the vehicle is moving. Preselection with the range preselection lever must be made prior to moving the shift lever out of gear into neutral.
5. Do not shift from high range to low range at high vehicle speeds.
6. Use double-clutching between all upshifts and downshifts that require movement of the shift lever.
7. After your shifting ability improves, you may want to skip some of the ratios. This may be done only when operating conditions permit, depending on the load, grade, and road speed.

## Operation, 9-Speed Models

### Upshifting

1. Position the gear shift lever in neutral. See [Fig. 5.4](#) for the shift pattern. Start the engine, and bring the air system pressure up to 95 to 125 psi (655 to 862 kPa).
2. Position the range preselection lever down into low range.

3. Depress the clutch pedal to the floor. Shift into low or 1st gear, then engage the clutch, with the engine at or near idle rpm, to start the vehicle moving.
4. Shift progressively upward from low or 1st gear through 4th gear, double-clutching between shifts.

Use only enough speed to keep the engine above peak torque rpm after the upshift. The engine may need to be at rated rpm before upshifts.

5. While in the 4th gear and ready for the next upshift, flip the range preselection lever up into high range. Double-clutch through neutral, and shift into 5th gear. As the shift lever passes through neutral, the transmission will automatically shift from low range to high range.
6. With the transmission in high range, shift progressively upward through 8th gear, double-clutching between shifts.

## Downshifting

1. With the transmission in high range, shift progressively downward to 5th gear, double-clutching between shifts.
2. When in 5th gear and ready for the next downshift, push the range preselection lever down into low range. Double-clutch through neutral, and shift into 4th gear. As the shift lever passes through neutral,

the transmission will automatically shift from high range to low range.

3. With the transmission in low range, downshift through the low range gears as conditions require.

## Operation, 10-Speed Models

### Upshifting

1. Position the gear shift lever in neutral. See [Fig. 5.5](#) or [Fig. 5.6](#) for the shift pattern. Start the engine, and bring the air system pressure up to 95 to 125 psi (655 to 862 kPa).
2. Position the range preselection lever down, into low range.
3. Depress the clutch pedal to the floor. Shift into 1st gear; then, engage the clutch with the engine at or near idle rpm to start the vehicle moving.
4. Shift progressively upward from 1st gear through 5th gear, always double-clutching between gears.

Use only enough speed to keep the engine above peak torque rpm after the upshift. The engine may need to be at rated rpm before upshifts.

5. While in 5th gear and ready for the next upshift, flip the range preselection lever up into high range. Double-clutch through neutral, and shift into 6th gear. As the shift lever passes through neutral, the

# Transmissions

---

auxiliary section will automatically shift from low range to high range.



## CAUTION

**Never move the range preselection lever with the shift lever in neutral while the vehicle is moving. Always preselect the range shift before moving the shift lever. Failure to do so can cause the gears to grind.**

6. With the transmission in high range, shift progressively upward through 8th gear, always double-clutching between gears.

### Downshifting

1. With the transmission in high range, shift progressively downward to 6th gear, always double-clutching between gears.
2. When in 6th gear and ready for the next downshift, push the range preselection lever down into low range. Double-clutch through neutral, and shift into 5th gear. As the shift lever passes through neutral, the transmission will automatically shift from high range to low range.
3. With the auxiliary section in low range, downshift through the low range gears as conditions require, always double-clutching between gears.

## Operation, 13-Speed Models with Splitter

Low gear in the front section is used only as a starting ratio. The remaining four forward positions are used once in the LO range and once in the HI range. However, each of the four High range gear positions can be split. Ratios cannot be split while the transmission is in LO range.

**IMPORTANT:** The shift knob has an interlock feature that prevents the splitter control button from being moved forward when the range preselection lever is down (in LO range), and, when in HI range with the splitter control button forward, prevents the range preselection lever from being moved down.

1. Use double-clutching between all upshifts and downshifts that require movement of the shift lever. Splitting of the High range gears does not require movement of the shift lever.
2. Never attempt to move the shift lever into Low gear while in High range.
3. Never move the splitter control button while in Neutral.

4. Do not preselect with the splitter control button; after moving the control button, complete the shift immediately.
5. Except when downshifting from 5th direct to 4th gear, never push the range preselection lever down into LO range while operating in HI range—the splitter will become inoperative.
5. Shift upward from Low to 1st gear, 2nd, etc. until 4th gear, double-clutching between shifts, and accelerating to 80 percent of engine governed speed.
6. When in 4th gear and ready to shift up to 5th gear, use the range shift lever as follows:

## Upshifting

1. Position the gear shift lever in neutral. Start the engine, and bring the air system pressure within 95 to 125 psi (655 to 862 kPa).
2. Make sure the range preselection lever is down (in LO range).
3. Make sure the splitter control button is in the direct (aft) position.
4. Start the vehicle.
  - 4.1 Press the clutch to the floor.
  - 4.2 Shift into Low or 1st gear.
  - 4.3 Release the clutch, with the engine at or near idle speed, to start the vehicle moving.
  - 4.4 Accelerate to 80 percent of engine governed speed.
- 6.1 While in 4th gear, pull the range shift preselection lever up, into HI range.
- 6.2 Disengage the clutch and double-clutch through neutral. The transmission will automatically shift from LO to HI range as the shift lever passes through neutral.
- 6.3 Move the shift lever to 5th gear.
- 6.4 Engage the clutch and accelerate the engine.
7. Shift up through the HI range gears as follows:
  - 7.1 To shift from 5th direct to 5th overdrive, move the splitter control button into the overdrive (forward) position, then immediately release the accelerator. Press and release the clutch pedal. After releasing the clutch, accelerate again.
  - 7.2 Continue upshifting through the shift pattern. Double-clutch during lever shifts (6th to 7th to 8th); single-clutch during split shifts (6th direct to 6th overdrive, etc.).

# Transmissions

---

## Downshifting

1. Downshift from 8th overdrive to 8th direct without moving the shift lever.
  - 1.1 Move the splitter control button to the direct (aft) position. Immediately release the accelerator, and disengage the clutch.
  - 1.2 Engage the clutch, and accelerate the engine only after the transmission has shifted.
2. Downshift from 8th direct to 7th overdrive.
  - 2.1 Start the downshift by moving the splitter control button to the overdrive (forward) position.
  - 2.2 Immediately double-clutch through neutral, moving the shift lever from 8th to 7th gear
3. Shift downward through each of the HI range gears, alternating the procedures in steps 1 and 2, above, until reaching 5th direct.
4. While in 5th direct and ready for the downshift to 4th, push the range preselection lever down. Then, double-clutch through neutral and move the shift lever to the 4th gear position.
5. Continue downshifting from 4th to 1st as conditions require.

## Operation, Deep-Reduction Models

### Upshifting

1. Position the gear shift lever in neutral. See [Fig. 5.8](#) for the shift pattern. Start the engine, and bring the air system pressure up to 95 to 125 psi (655 to 862 kPa).
2. Position the range preselection lever down, into low range.

NOTE: If conditions are difficult, start out in LO-LO. Move the deep reduction lever on the dashboard to the IN position. Otherwise start out in LO with the deep reduction lever in the OUT position.

3. Depress the clutch pedal to the floor. Shift into LO gear; then, engage the clutch, with the engine at or near idle rpm to start the vehicle moving. The vehicle will start in LO or LO-LO depending on the deep reduction lever position.
4. To upshift if in LO-LO, move the deep reduction lever to the OUT position and *immediately* release the accelerator, depress the clutch pedal once to break torque, and reengage the clutch. The auxiliary section will shift from LO-LO to LO when the gears reach the same speed.

5. Shift progressively upward from LO through 1st, 2nd, 3rd, and 4th gears while the range preselection lever is in LO. Always double-clutch between gears.
6. When in 4th gear and ready for the next upshift, pull up the range preselection lever and move the shift lever, double-clutching, to the 5th gear position. As the shift lever passes through neutral, the auxiliary section will automatically shift from low to high range.



## CAUTION

**Never move the shift lever into the LO gear position after high range preselection or anytime the auxiliary section is in high range. Transmission damage could result.**

7. Continue upshifting from 5th gear through 8th gear, always double-clutching between gears.

### Downshifting

1. While in high range, move the gear shift lever from 8th gear through 5th gear as conditions require, always double-clutching between gears.
2. When in 5th gear and ready for the next downshift, push down the range preselection lever and move the shift lever to the 4th gear position, being sure to

double-clutch. As the shift lever passes through neutral, the auxiliary section will automatically shift from high to low range.

3. While in the low range, continue downshifting from 4th through LO as conditions require, always double-clutching between gears.
4. *Do not* downshift into LO-LO from LO unless operating conditions make it necessary. If it is necessary, make sure that the shift lever is in the LO gear position and the auxiliary section is in the low range. Then, move the DEEP REDUCTION lever on the dashboard to the IN position. *Immediately* release the accelerator, depress the clutch pedal once to break torque, engage the clutch, and accelerate. The auxiliary section will automatically shift from LO to LO-LO when the gears reach the same speed.

## Eaton Fuller Super 10 Models

Refer to the Eaton web site for additional information, [www.roadranger.com](http://www.roadranger.com). A connection to the Internet is required.

### General Information, Super 10

#### 10-Speed RTLO Models

Eaton Fuller Super 10 transmissions have ten selective forward ratios and a two-speed rear range section. Half

# Transmissions

of the 10 speed ratios are shifted with the shift lever and the other half are shifted by moving the shift button.

There are three types of shifts used with the Super 10 transmission. The button-only shift is a gear range shift that occurs by moving the shift button (see [Fig. 5.9](#)). The lever-only shift occurs when the shift lever is moved without moving the shift button. The combination button/lever shift is a gear ratio change that occurs by moving both the shift button and the shift lever. Button-only and combination button/lever shifts are both full gear changes and the lever-only shift skips a gear. See [Fig. 5.10](#) for the shift patterns.

Top-2 (T2) transmissions are equipped with an optional feature that allows the transmission to automatically shift between the top two gears (9th-10th) without the need for button shifts.

## Operation, Super 10

1. When operating off-highway, or under adverse conditions, always use low gear (if so equipped) when starting to move the vehicle.

When operating on-highway, with no load, or under ideal conditions, use 1st gear when starting to move the vehicle.

For all conditions, use the highest gear that is still low enough to start the vehicle moving with engine idling, and without slipping the clutch excessively.

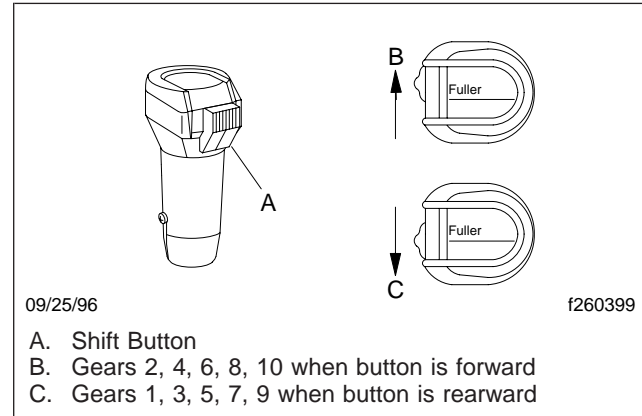

**Fig. 5.9, Super 10 Shift Knob**

2. Use the clutch brake to stop gear rotation when shifting into 1st or reverse when the vehicle is stationary. The clutch brake is actuated by depressing the clutch pedal all the way to the floor.

For normal upshifts and downshifts, only a partial disengagement of the clutch is necessary to break engine torque.

3. Do not make range shifts with the vehicle moving in reverse gear.



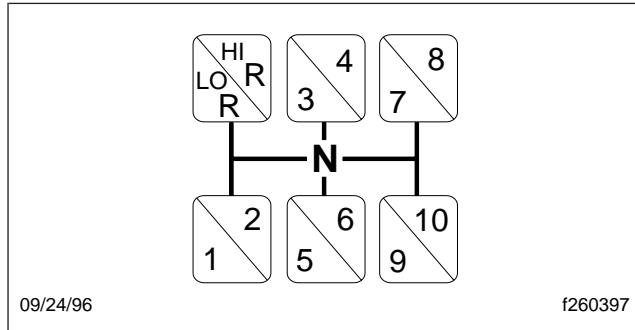

**Fig. 5.10, Super 10 Transmission Shift Pattern**

4. The shift lever should not be moved to the center or left rail positions at vehicle speeds above 40 mph (65 km/h).
5. Use double-clutching between all upshifts and downshifts.
6. After your shifting ability improves, you may want to skip some of the ratios. This may be done only when operating conditions permit, depending on the load, grade, and road speed.

## ⚠ CAUTION

Failure to keep the transmission in gear at all times with the vehicle in motion could lead to transmission damage.

7. Avoid hunting for neutral by moving the gear shift lever from the left rail to right rail. This action can cause excessive transmission wear.

### Upshifting

1. Position the gear shift lever in neutral. Start the engine, and bring the air system pressure up to 100 to 120 psi (689 to 827 kPa).
2. Depress the clutch pedal to the floor. Shift into 1st gear, then engage the clutch, with the engine at or near idle speed, to start the vehicle moving.
3. Button shift—Preselect the next gear by sliding the shift button forward. Break torque by releasing the throttle or by depressing the clutch pedal. Decrease engine speed to synchronize the engine speed with the transmission speed. The shift will complete when the engine rpm has decreased to the proper speed. The button only shift is used for gear changes from 1st to 2nd, 3rd to 4th, 5th to 6th, 7th to 8th, and 9th to 10th.

# Transmissions

---

4. Combination button and lever shift—Preselect the next gear by sliding the shift button rearward. Break torque by releasing the throttle and depressing the clutch pedal. Double-clutching, move the shift lever to the next desired gear position. The combination button and lever shift is used for gear changes from 2nd to 3rd, 4th to 5th, 6th to 7th and 8th to 9th.
5. Lever only shift—Break torque by releasing the throttle and depressing the clutch pedal. Double-clutching, move the shift lever to the next desired gear position. Decrease engine speed to synchronize the engine speed with the transmission speed. The shift will complete when the engine rpm has decreased to the proper speed. The lever only shift is used to skip a full gear. With the shift button rearward—1st to 3rd, 3rd to 5th, 5th to 7th, and 7th to 9th. With the shift button forward—2nd to 4th, 4th to 6th, 6th to 8th, 8th to 10th.

NOTE: Lever only shifts skip an entire gear ratio and will require the engine rpm to decrease twice the amount of a normal shift.

## Downshifting



### CAUTION

---

**Do not attempt a button only downshift at too high of an engine speed (generally above 1400 rpm). Do-**

**ing so could result in damage to the engine, transmission, and/or driveline.**

1. Button shift—With the throttle still applied, preselect the next gear by sliding the shift button rearward. Break torque by releasing the throttle or by depressing the clutch pedal. Increase engine speed to synchronize the engine speed with the transmission speed. The shift will complete when the engine rpm has increased to the proper speed. The button only shift is used for gear changes from 10th to 9th, 8th to 7th, 6th to 5th, 4th to 3rd, and 2nd to 1st.



### CAUTION

---

**Do not attempt a combination button and lever downshift at too high of an engine speed (generally above 1400 rpm). Doing so could result in damage to the engine, transmission, and/or driveline.**

2. Combination button and lever shift—With the throttle still applied, preselect the next gear by sliding the shift button forward. Break torque by releasing the throttle and depressing the clutch pedal. Double-clutching, move the shift lever to the next desired gear position. The combination button and lever shift is used for gear changes from 9th to 8th, 7th to 6th, 5th to 4th, and 3rd to 2nd.

## CAUTION

**Do not attempt a lever only downshift at too high of an engine speed (generally above 1000 rpm). Doing so could result in damage to the engine, transmission, and/or driveline.**

3. Lever-only shift—Break torque by releasing the throttle and depressing the clutch pedal. Double-clutching, move the shift lever to the next desired gear position. The lever-only shift is used to skip a full gear. With the shift button rearward—9th to 7th, 7th to 5th, 5th to 3rd, and 3rd to 1st. With the shift button forward—10th to 8th, 8th to 6th, 6th to 4th and 4th to 2nd.

NOTE: Never use the clutch brake when downshifting, or as a brake to slow the vehicle.

## Eaton Fuller AutoSelect Automated Transmissions

### General Information, AutoSelect

#### 10-Speed RTAO Models

Eaton Fuller 10-speed RTAO models have 10 forward speeds and two reverse speeds. The transmission consists of a five-speed front section and a two-speed rear

section. The driver must use the clutch to start and stop the vehicle.

When conditions are right for a shift, the transmission Electronic Control Unit (ECU) notifies the driver with a tone from the Driver Command Console (DCC). See [Fig. 5.11](#). The driver, when ready to shift, breaks torque and the transmission goes to neutral. The driver then either increases or decreases engine speed to synchronize the shift. When engine speed is correct, the transmission shifts automatically.

The AutoSelect system consists of the following components.

- The Driver Display Module, or DDM ([Fig. 5.12](#)), mounted on the dashboard, indicates gear position and the direction engine rpm needs to go for the next gear engagement. When the gear select lever is in the "D" position, the display module indicates what the driver must do to engage the next gear (decelerate or accelerate) by down and up arrows. When the gear number is solid on the display, that gear is fully engaged. When the gear number is flashing the transmission is either out of gear, waiting for the engine and transmission to synchronize, or the next gear engagement is in process.
- The Driver Command Console, or DCC ([Fig. 5.11](#)), replaces the shift lever and controls the transmission's shift patterns. There are indicators

# Transmissions

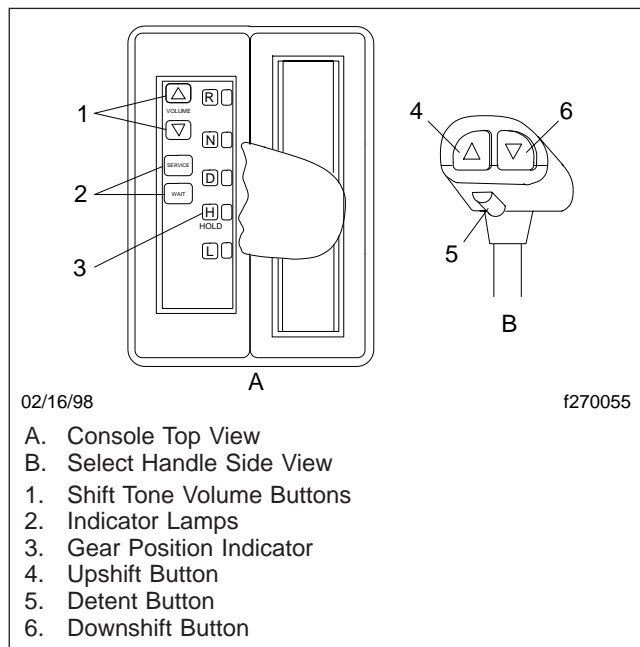

**Fig. 5.11, Driver Command Console (DCC)**

for the three forward positions: drive, hold, and low, plus reverse and neutral positions. Shift tone volume buttons and service and wait lamps are also located on the console. The gear select

handle contains upshift and downshift buttons and a gear select lever detent button.

- The shifter performs shifts at the front portion of the transmission. It preselects the shift to neutral and completes the gear change after driver input.
- The Electronic Control Unit (ECU) consists of two controllers: a transmission ECU and a system ECU. The transmission ECU controls all transmission shift functions and the system ECU manages all vehicle interfaces for transmission shift functions.
- An electronic range valve, controlled by the transmission ECU, is used to perform range shifts.

## Operation, AutoSelect



**If the engine cranks in any gear other than neutral, have the vehicle serviced immediately. If the vehicle is started in gear it will suddenly move forward or backward, which could result in personal injury and damage to property and the transmission.**

### Reverse

NOTE: To drive in reverse, first depress the clutch.

1. Move the gear select lever to the "R" position.

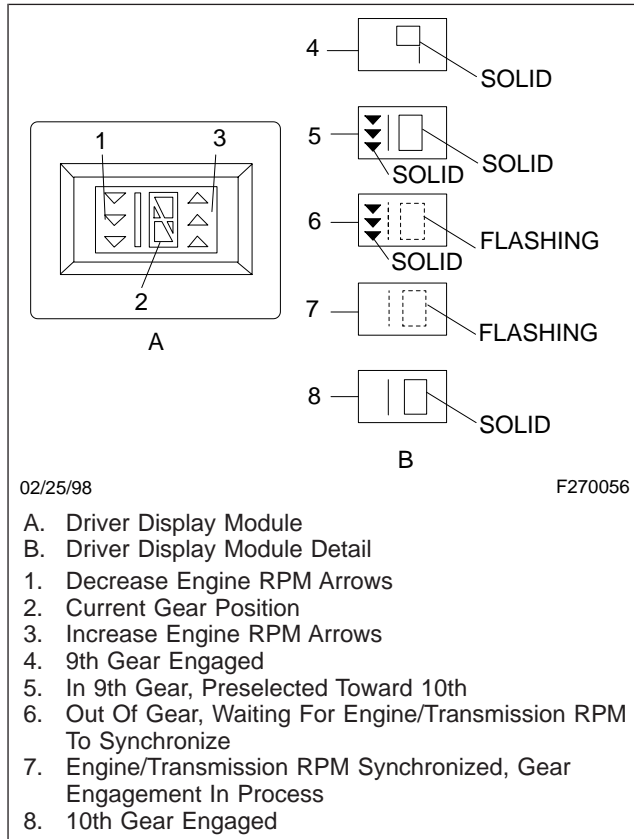

**Fig. 5.12, Driver Display Module (DDM)**

2. Select either LO or HI reverse by depressing either the downshift or upshift button (Fig. 5.11) on the gear select handle.
3. Release the clutch.

**NOTE:** The clutch must be used for starting and stopping.

### Upshifting ("D" and "H" modes)

**NOTE:** It is the driver who decides when to upshift or downshift. When in the "D" mode, an upcoming shift can be cancelled by putting the gear select lever in the "H" mode or by using the gear select handle buttons. When in the "H" mode, it is possible to skip shift gears if the road and load conditions permit.

1. Accelerate.

**NOTE:** In the "H" mode, depress the upshift button on the gear select handle. Depress twice to skip shift.

2. An audible tone sounds from the Driver Command Console when the transmission is ready to shift. The arrows on the Driver Display Module (Fig. 5.12) indicate the direction engine rpm needs to go to synchronize the next shift. The next gear is shown on the display. See Fig. 5.12.

# Transmissions

---

3. Release the throttle for the shift to neutral. The upcoming gear flashes on the display when neutral is engaged. The arrows disappear, the current gear position stops flashing, and engine rpm decreases and becomes steady.

4. Apply the throttle.

NOTE: If the shift is missed, control engine speed in the direction indicated by the arrows on the display to synchronize engine rpm with the transmission's speed.

## **Downshifting ("D" and "H" modes without an engine load)**

1. Decelerate

NOTE: In the "H" mode, depress the downshift button on the gear select handle. Depress twice to skip shift.

2. An audible tone sounds from the Driver Command Console when the transmission is ready to shift. The arrows on the Driver Display Module indicate the direction engine rpm needs to go to synchronize the next shift. The next gear is shown on the display.
3. Gently roll on the throttle. The upcoming gear flashes on the display when neutral is engaged. The arrows disappear, the current gear position

stops flashing, and engine rpm increases and becomes steady.

4. Continue decelerating.

NOTE: If the shift is missed, control engine speed in the direction indicated by the arrows on the display to synchronize engine rpm with the transmission's speed.

## **Downshifting ("D" and "H" modes with an engine load)**

1. Decelerate

NOTE: In the "H" mode, depress the downshift button on the gear select handle. Depress twice to skip shift.

2. An audible tone sounds from the Driver Command Console when the transmission is ready to shift. The arrows on the Driver Display Module indicate the direction engine rpm needs to go to synchronize the next shift. The next gear is shown on the display.
3. Release the throttle. The upcoming gear flashes on the display when neutral is engaged.
4. Apply throttle to synchronize engine rpm with the transmission's speed. The arrows disappear, the

current gear position stops flashing, and engine rpm increases and becomes steady.

**NOTE:** If the shift is missed, control engine speed in the direction indicated by the arrows on the display to synchronize engine rpm with the transmission's speed.

## Eaton Fuller AutoShift™

Refer to the Eaton web site for additional information, [www.roadranger.com](http://www.roadranger.com). A connection to the Internet is required.

**IMPORTANT:** Before starting the vehicle, always do the following:

- Be seated in the driver's seat.
- Place the transmission in neutral.
- Set the parking brakes.
- Press the clutch pedal down to the floor.

The AutoShift AS2 is a partially automated 10-speed or 18-speed Eaton Fuller transmission. The AutoShift ASX is a partially automated 6-speed or 7-speed Eaton Fuller transmission. For all, the driver must use the clutch and put the transmission in neutral to start and stop the vehicle. A push-button shift selector (**Fig. 5.13**) is used with AutoShift transmissions.

**IMPORTANT:** If you have to leave the cab with the engine running:

- Place the transmission in neutral.
- Set the parking brakes.
- Chock the tires.

## Push-Button Shift Selector

Gear information is presented to the driver on the push-button shift selector, usually mounted on the right-hand control panel. On this display, the information is presented as follows:

- To select neutral, press the N button. When neutral is engaged, the telltale LED will light up next to the N button.
- To select reverse, press the R button. When reverse is engaged, the telltale LED will light up next to the R button.
- To select drive, press the D button. When drive is engaged, the telltale LED will light up next to the D button.
- To select low gear, press the LOW button. When low is engaged, the telltale LED will light up next to the LOW button.
- To change gears manually, press the MANUAL button. When the manual mode is engaged, the

# Transmissions

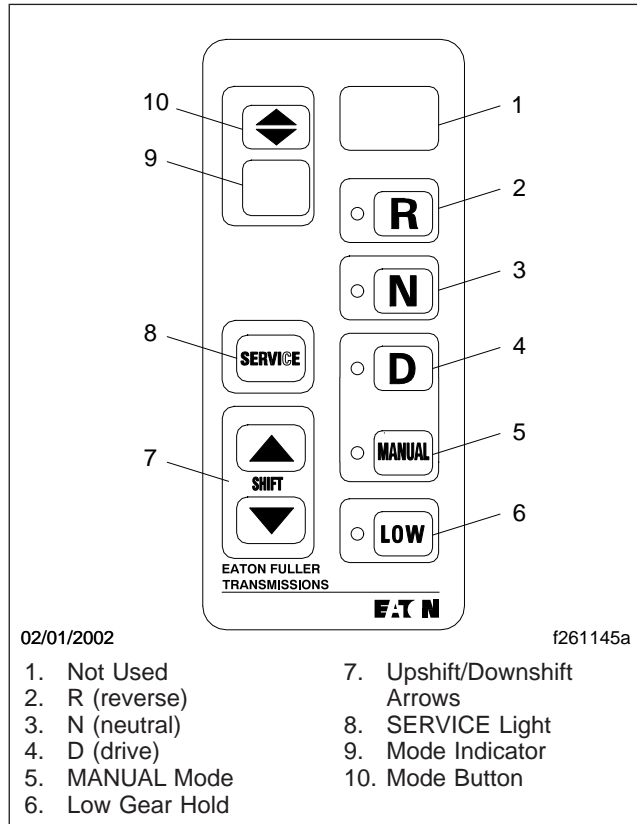

Fig. 5.13, Eaton Push-Button Shift Selector

telltale LED will light up next to the MANUAL button.

- Use the shift buttons (upshift/downshift) to change the current starting gear selection in R, D, and LOW. In MANUAL, the shift buttons can be used to select gears.
- In automatic mode, the number of the forward gear currently engaged appears continually on the mode indicator when in drive. In MANUAL, the last gear selected appears on the mode indicator.
- If the SERVICE indicator illuminates, take the vehicle as soon as possible to an authorized Freightliner service facility.
- The mode button is reserved for future use.

**IMPORTANT:** To prevent engine overspeed, the transmission software will override both MANUAL and LOW if necessary. The system will not respond to gear selection requests that will either overspeed or excessively lug the engine.

## Automatic Mode

The AutoShift transmission is normally operated in an automatic mode. To select MANUAL mode, press the MANUAL button on the push-button shift selector.



When the transmission is in automatic mode, the transmission automatically selects and engages the gears, although the transmission will respond to upshift and downshift requests as though in manual mode. See the instructions for shifting under heading "Manual Mode" below.

## Manual Mode

When the transmission is in manual mode, the driver must select the appropriate gear, using the shift buttons on the push-button shift selector.

To upshift in MANUAL, press the upshift button (up arrow), and release. The number of the gear will appear on the mode indicator. If the requested gear is available, the transmission will shift up.



## CAUTION

**Do not attempt to upshift until the vehicle has reached a sufficient speed. The clutch absorbs the speed difference by generating heat, which causes the clutch to wear out too soon.**

Many drivers upshift into the next gear or even skip-shift into a higher gear before the vehicle has reached the correct speed. This type of shifting is almost as bad as starting off in a gear that is too high. When the engine speed (rpm) and the vehicle speed (mph or km/h)

are too far apart, the clutch must absorb the difference in speed by generating heat.

To downshift in MANUAL, press the downshift button (down arrow), and release. The number of the gear will appear on the mode indicator. If the requested gear is available, the transmission will shift down.

If any requested gear is not available, an audible warning will sound and the digital display will indicate that the gear is not available.

## Selecting Gears, AutoShift

### R (Reverse)

Reverse (R) is used to back the vehicle. Make sure the vehicle comes to a full stop and the clutch pedal has been pressed before shifting into reverse.

To select reverse, press the clutch pedal to the floor. Then press the R button.

### N (Neutral)

Neutral (N) is used for starting, parking, or any stationary operation. No gear is selected. The transmission must be in neutral to start the engine.

**IMPORTANT:** If the vehicle starts up in any gear but neutral, bring the vehicle to an authorized Freightliner service facility as soon as possible.

# Transmissions

---

To select neutral, press the clutch pedal to the floor. Then press the N button. Set the parking brakes and slowly release the clutch pedal.

NOTE: Neutral is always available during vehicle operation. When in neutral, requests to upshift or to downshift are ignored.

## D (Drive)

Drive (D) is used for normal highway driving. In drive, the transmission shifts into the proper gear for starting, and then automatically selects additional gears as needed, in a range between the starting gear and the highest gear.

To select drive, press the clutch pedal to the floor. Then press the D button. Slowly release the clutch pedal and drive the vehicle.

To start up in a gear other than the normal starting gear, push the upshift arrow with D selected, and while the vehicle is stopped.

IMPORTANT: Autoshift will not start up in any gear higher than third gear.

The number of the gear selected will flash on the auxiliary display until the driver presses the clutch pedal. This gear will be stored in memory as the default starting gear until a different starting gear is selected by the driver, or until the engine is shut down.

NOTE: The transmission may be programmed so that it is not possible to select a starting gear other than the preprogrammed starting gear.

## L (Low)

LOW is used to hold the transmission in low gear when descending steep hills. If LOW is selected when the vehicle is stopped, the transmission remains in low gear until drive is selected. If LOW is selected while the vehicle is moving, the transmission downshifts at a higher engine speed than normal, in order to maximize the engine braking effect.

To select LOW, press the clutch pedal to the floor. Then press the LOW button. Slowly release the clutch pedal and drive the vehicle.

IMPORTANT: Before parking the vehicle, always do the following:

- Place the transmission in neutral.
- Set the parking brakes.
- Chock the tires, if parking on an incline.

## Meritor Range-Shift Models

Refer to the Meritor web site for additional information, [www.arvinmeritor.com](http://www.arvinmeritor.com). A connection to the Internet is required.

## General Information, Meritor Range-Shift

### 9-Speed Models

Meritor 9-speed range-shift transmissions have a five-speed front section, and a two-speed auxiliary section. The low gear in the front sections of the "A" and "B" ratio transmissions is used only as a starting ratio. The high gear in the front section of the "R" ratio transmissions is used only as the top gear. The remaining gear positions of the above transmissions are used once in the low range and once in the high range. See [Fig. 5.14](#) for the shift patterns.

NOTE: The 3rd/7th and 4th/8th shift positions in the RM and RMX (direct ratio) are opposite of the RMO (overdrive ratio) transmissions. The RMX-R ratio transmissions have the 1st/5th shift positions where low is in the A and B ratio transmissions. The top gear in the RMX-R ratio transmissions is called 9th gear.

### 10-Speed Models

Meritor 10-speed range-shift transmissions have 10 evenly-spaced forward ratios. Each transmission consists of a five-speed front section, and a two-speed auxiliary section. The 10 forward speeds are obtained by twice using a five-speed shift pattern: the 1st time in

low range, the 2nd time in high range. See [Fig. 5.15](#) for the shift pattern.

## Operation, Meritor Range-Shift

**IMPORTANT:** Always use the correct gear. Using the correct gear can prevent shock load to the transmission. Shock load can damage gear teeth immediately or cause damage that appears later.

### Reverse

To drive in reverse, push the range selector lever down and put the transmission in the low range. Push the clutch pedal to the bottom of its travel, so that the clutch brake slows the transmission for initial gear engagement. While holding the clutch pedal at the bottom of its travel, shift into reverse.

Slowly release the clutch pedal and move the vehicle in reverse.

### Upshifting

1. To drive forward, make sure the vehicle is completely stopped and that the range selector lever is pushed down to put the transmission in the low range.

# Transmissions

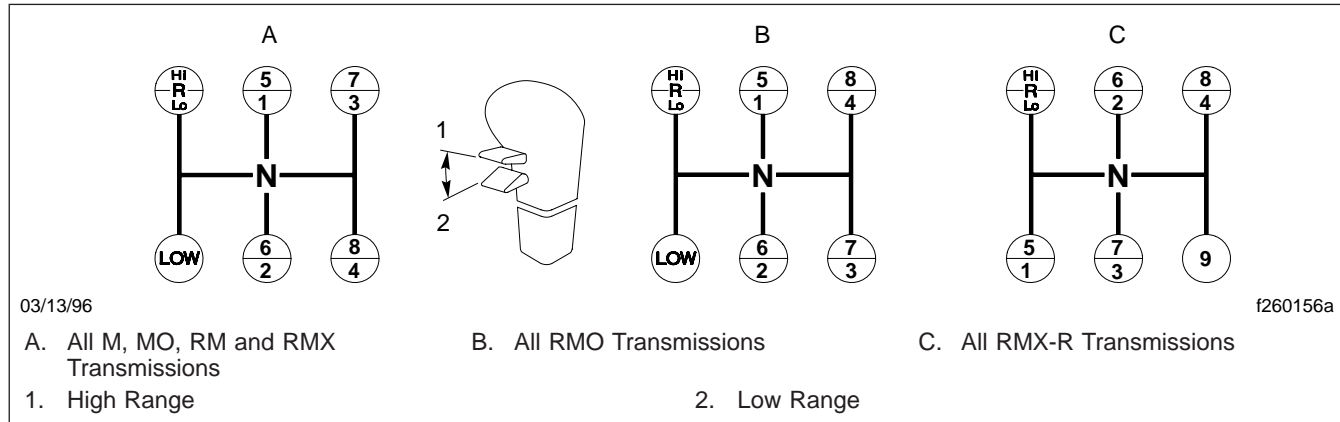

**Fig. 5.14, Meritor 9-Speed Transmission Shift Patterns**

2. Push the clutch pedal to the bottom of its travel, so that the clutch brake slows the transmission for initial gear engagement. While holding the clutch pedal at the bottom of its travel, shift into low gear.
3. Slowly release the clutch pedal and begin moving the vehicle forward.
4. To upshift into 1st gear, only partial depression of the clutch pedal is needed. Do not push the clutch pedal all the way to the floor and engage the clutch brake. Instead, partially depress the clutch pedal, and move the shift lever into neutral.
5. Release the clutch, and allow the engine to decelerate until the road speed and the engine rpm match.
6. Partially depress the clutch pedal, and move the shift lever into 1st gear.
7. Double clutch and continue upshifting until you reach the top gear in the low range, 4th gear in nine-speed models, 5th gear in 10-speed models. See [Table 5.1](#).

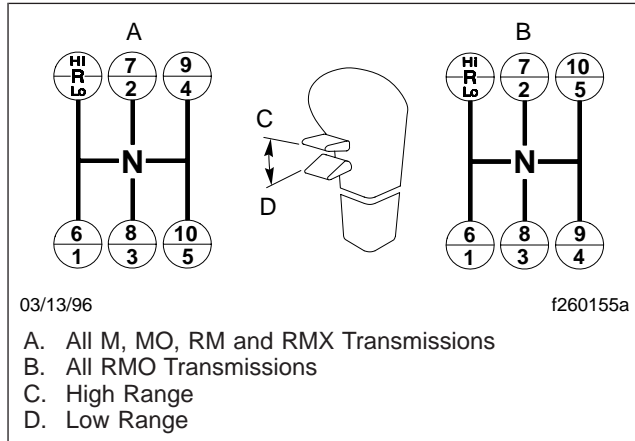

Fig. 5.15, Meritor 10-Speed Transmission Shift Patterns

Meritor Shift Progressions			
TRANS. MODEL	LOW RANGE		HIGH RANGE
	Off-Highway	On-Highway	
9-Speed Direct or Overdrive (All Others)	<p>f260322</p>	<p>f260321</p>	<p>f260320</p>

Meritor Shift Progressions			
TRANS. MODEL	LOW RANGE		HIGH RANGE
	Off-Highway	On-Highway	
9-Speed Direct (RMX-R)	<p>f260325</p>	<p>f260325</p>	<p>f260326</p>
9-Speed Overdrive (RMO)	<p>f260327</p>	<p>f260327</p>	<p>f260328</p>
10-Speed Direct or Overdrive (All Others)	<p>f260329</p>	<p>f260329</p>	<p>f260330</p>
10-Speed Overdrive (RMO)	<p>f260331</p>	<p>f260331</p>	<p>f260332</p>

Table 5.1, Meritor Shift Progressions

- To upshift into high range—with the transmission still in the highest low-range gear—move the range selector lever up and put the transmission into high range, then partially depress the clutch pedal and move the shift lever into neutral. As the shift lever

# Transmissions

---

passes through neutral, the transmission will automatically shift from low range to high range.

9. Release the clutch pedal, and let the engine slow until the road speed and engine rpm match.
10. Partially depress the clutch pedal, and move the shift lever into the lowest gear in the high range-5th gear in nine-speed models, 6th gear in 10-speed models.
11. Double clutch and continue upshifting.

## Downshifting

1. With the transmission in high range, shift progressively downward to the bottom gear in high range, 5th gear in nine-speed models, 6th gear in 10-speed models. Double-clutch between shifts. See [Table 5.1](#).
2. When in the bottom gear of the high-range shift pattern, and ready for the next downshift, push the range selection lever down into low range. Double-clutch through neutral, and shift into the top gear of the low-range shift pattern. As the shift lever passes through neutral, the transmission will automatically shift from high range to low range.
3. With the transmission in low range, downshift through the low range gears as conditions require.

**NOTE:** Never fully depress the clutch pedal to use the clutch brake when downshifting, or as a brake to slow the vehicle.

## Meritor Splitter and Range-Shift Models

### General Information, Splitter and Range-Shift

The Meritor 13-speed transmission has 13 forward speeds and two reverse speeds. Each transmission consists of a five-speed front section, and a three-speed auxiliary section. The auxiliary section contains low- and high-range ratios, plus, an overdrive splitter gear. See [Fig. 5.16](#).

All of the 13 speeds are controlled with one shift lever. Built into the shift knob of the lever, are a range selection lever and a splitter control button (on the side of the shift knob) that control range selection and gear splits, respectively.

Low gear in the front section is used only as a starting ratio. The remaining four forward positions are used once in the low range and once in the high range. However, each of the four high range gear positions can be split with the overdrive ratio of the splitter gear. Ratios cannot be split while the transmission is in low range.

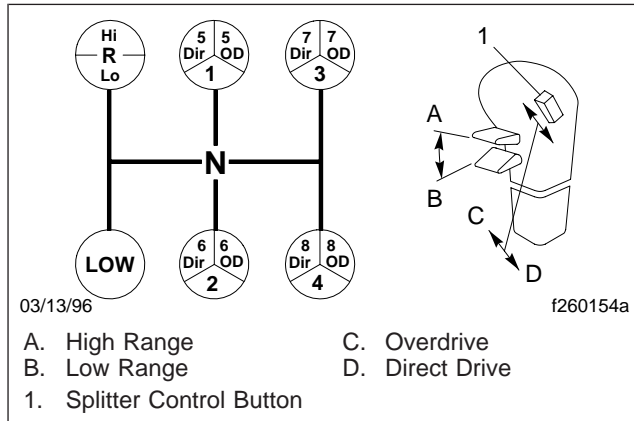

**Fig. 5.16, Meritor 13-Speed Transmission Shift Pattern**

## Operation, Splitter and Range-Shift

**IMPORTANT:** The shifter knob has an interlock feature that prevents the splitter control button from being moved up when the range selection lever is down (in the low range). When the transmission is in the high range, and the splitter control button is up, the range selection lever cannot be moved down.

## Reverse

To drive in reverse, push the range selector lever down and put the transmission in the low range. Push the clutch pedal to the bottom of its travel, so that the clutch brake slows the transmission for initial gear engagement. While holding the clutch pedal at the bottom of its travel, shift into reverse.

Slowly release the clutch pedal and move the vehicle in reverse.

## Upshifting

1. To drive forward, make sure the vehicle is completely stopped and that the range selector lever is pushed down, to put the transmission in the low range.
2. Push the clutch pedal to the bottom of its travel, so that the clutch brake slows the transmission for initial gear engagement. While holding the clutch pedal at the bottom of its travel, shift into low.
3. Slowly release the clutch pedal and begin moving the vehicle forward.
4. To upshift into 1st gear, only partial depression of the clutch pedal is needed. Do not push the clutch pedal all the way to the floor and engage the clutch brake. Instead, partially depress the clutch pedal, and move the shift lever into neutral.

# Transmissions

---

5. Release the clutch pedal, and allow the engine to decelerate until the road speed and the engine rpm match.
6. Partially depress the clutch pedal, and move the shift lever into 1st gear.
7. Double clutch and continue upshifting until in 4th gear. See [Table 5.1](#).
8. To upshift into high range—with the transmission still in 4th gear—push the range selection lever up and put the transmission into high range, then partially depress the clutch pedal and move the shift lever into neutral. As the shift lever passes through neutral, the transmission will automatically shift from low range to high range.
9. Release the clutch pedal, and let the engine slow until the road speed and engine rpm match.
10. Partially disengage the clutch, and move the shift lever into 5th gear.
11. To upshift from 5th gear into 5th overdrive, flip the splitter control button up to the overdrive position; then, immediately release the accelerator, and press and release the clutch pedal. It is not necessary to move the shift lever when shifting from direct to overdrive. The transmission will shift when synchronization with the engine's speed is reached.

Accelerate the engine only after the transmission has shifted.

12. To shift from 5th overdrive to 6th direct, partially disengage the clutch, shift into 6th—but before engaging the clutch—flip the splitter control button down into the direct drive position. Then engage the clutch, and accelerate the engine.

**NOTE:** Do not move the control button while the shift lever is in neutral.

13. Shift upward through each of the high range gears, alternating the procedures in steps 10 and 11, above.

## Downshifting

1. Downshift from 8th overdrive to 8th direct without moving the shift lever. Flip the splitter control button down to the direct drive position; then, immediately release the accelerator, and press and release the clutch pedal. Accelerate the engine only after the transmission has shifted.
2. To downshift from 8th direct to 7th overdrive, flip the splitter control button up to the overdrive position; then, immediately double-clutch through neutral, moving the shift lever from 8th to 7th gear.
3. Downshift through each of the high range gears alternating the procedures in steps 1 and 2 above, until reaching 5th direct.



4. While in 5th direct, and ready for the next downshift, push the range selection lever down into low range. Double-clutch through neutral, and shift into 4th gear. See [Fig. 5.16](#). As the shift lever passes through neutral, the transmission will automatically shift from high range to low range.
5. With the transmission in low range, downshift through the low range gears as conditions require.

NOTE: Never fully depress the clutch pedal to use the clutch brake when downshifting, or as a brake to slow the vehicle.

## Mercedes-Benz Manual Transmissions



**Operating a manual transmission with the fluid level higher or lower than recommended can result in transmission damage.**

Mercedes-Benz (MBT) transmissions use a simple 6-speed gear pattern as shown in [Fig. 5.17](#).

An unloaded vehicle can be started in second gear on level roads or slight grades. Loaded vehicles, or vehicles on substantial grades, must be started only in first gear.

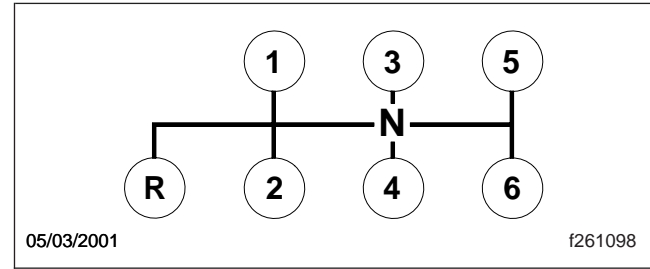

**Fig. 5.17, Shift Pattern, MBT Transmissions**

While traveling, check the tachometer regularly to be sure the engine speed is within the most economical range (1400-2000 rpm).

On level roads, drive in the highest usable gear, keeping engine speed down.

When approaching an uphill grade, shift down ahead of time to prevent loss of engine rpm. When approaching a downhill grade, shift down ahead of time to prevent runaway speed.

Change gears only when absolutely necessary. Skip gears if needed.

When shifting, always press the clutch pedal all the way down. Do not force the gear lever.

Before shifting into reverse, be sure the engine is idling and the vehicle is not moving.

# Transmissions

---

## CAUTION

If the transmission locks up while driving, making further shifting impossible, continue driving in the gear already selected, as circumstances allow. Proceed, if possible, directly to a Freightliner dealer or other qualified service provider. To prevent further transmission damage, do not move the vehicle from a standing start unless this can be accomplished safely, taking into account the gear that is engaged and the load on the vehicle.

## Allison Automatic Transmissions

Allison transmissions are fully automatic and include the 1000 Series™, 2000 Series™, 2400 Series™, and the MD series. Refer to the Allison web site for additional information, [www.allisontransmission.com](http://www.allisontransmission.com). A connection to the Internet is required.

## Safety Precautions, On-Highway Transmissions

### WARNING

Do not leave the vehicle unattended with the engine running. If you leave the vehicle and the engine is running, the vehicle can move suddenly, which could result in personal injury or property damage.

#### 1000 Series

On vehicles with Allison 1000 series transmissions, do the following steps if you have to leave the cab with the engine running (for example, when checking the transmission fluid):

#### Without Park Position

1. Bring the vehicle to a complete stop using the service brake.
2. Ensure that the engine is at low idle rpm.
3. Put the transmission in neutral.
4. Apply the emergency brake and/or parking brake, and make sure they are properly engaged.
5. Chock the rear tires and take any other steps necessary to keep the vehicle from moving.

## With Park Position

1. Bring the vehicle to a complete stop using the service brake.
2. Ensure that the engine is at low idle rpm.
3. Put the transmission in P (park).
4. Apply the parking brake (if equipped), and make sure it is properly engaged.
5. Engage the park range by slowly releasing the service brake.
6. Apply the emergency brake (if equipped), and make sure it is properly engaged.
7. Chock the rear tires and take any other steps necessary to keep the vehicle from moving.

## **2000 Series™**

On vehicles with Allison 2000 series transmissions, do the following steps if you have to leave the cab with the engine running (for example, when checking the transmission fluid):

## Without Auto-Apply Parking Brake

Follow the instructions for vehicles with 1000 series transmissions, under the heading "Without Park Position."

## With Auto-Apply Parking Brake

1. Bring the vehicle to a complete stop using the service brake.
2. Ensure that the engine is at low idle rpm.
3. Put the transmission in PB (auto-apply parking brake).
4. Apply the emergency brake (if equipped), and make sure it is properly engaged.
5. Chock the rear tires and take any other steps necessary to keep the vehicle from moving.

## **2400 Series™**

On vehicles with 2400 series transmissions, follow the instructions for vehicles with 1000 series transmissions.

1. Bring the vehicle to a complete stop using the service brake.
2. Ensure that the engine is at low idle rpm.
3. Put the transmission in P (park).
4. Apply the parking brake (if equipped), and make sure it is properly engaged.
5. Engage the park range by slowly releasing the service brake.

# Transmissions

---

6. Apply the emergency brake (if equipped), and make sure it is properly engaged.
7. Chock the rear tires and take any other steps necessary to keep the vehicle from moving.

## Range Inhibit Indicator, 2000 and 2400 Series

A RANGE INHIBIT indicator is a standard feature of the 2000 series and 2400 series transmissions. The RANGE INHIBIT indicator comes on to alert the driver that transmission operation is being inhibited and that the range shifts being requested by the driver may not occur. When certain operating conditions are detected by the TCM (transmission control module), the controls will lock the transmission in the current operating range.

Shift inhibits occur under the following conditions:

- Shifts from neutral to reverse or from neutral to a forward range when the engine is above idle, greater than 900 rpm.
- Forward/reverse directional shifts are typically not permitted if appreciable output shaft speed is detected.
- When some types of unusual transmission operating conditions are detected by the TCM, the TCM temporarily limits transmission operation until the vehicle can be driven to a service loca-

tion. When this type of situation is detected, the TCM will lock the transmission in a safe gear range.

- The TCM will prevent shifts from park or neutral to range when auxiliary equipment, such as a power takeoff unit (PTO), is in operation.

## Operating Instructions, On-Highway Transmissions

Allison automatic transmissions are electronically controlled and come with a push-button shift selector. See [Fig. 5.18](#). It provides five or six forward ranges and one reverse range.

### **P (Park, optional on 1000 and 2400 Series)**

Use park when turning the engine on or off, to check vehicle accessories, to operate the engine in idle for longer than 5 minutes, and for stationary operation of the power takeoff, if equipped. This position places the transmission in neutral and engages the park pawl.

### **PB (Auto-Apply Parking Brake, optional on 2000 Series)**

The auto-apply parking brake places the vehicle in neutral and applies the park brake.

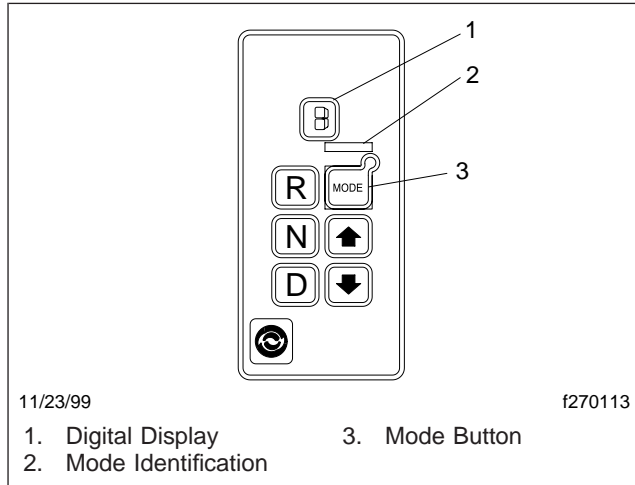

**Fig. 5.18, Allison Push-Button Shift Selector**

## R (Reverse)

Reverse is used to back the vehicle. When the selector is in reverse, the reverse warning signal will sound. Always bring the vehicle to a complete stop before shifting from a forward range to reverse, or from reverse to a forward range.

## CAUTION

**Extended idling in reverse may cause transmission overheating and damage.**

Do not idle in reverse for more than 5 minutes. Select P (park), PB (auto-apply parking brake), or N (neutral) when time at idle exceeds 5 minutes.

NOTE: The shift into reverse may not succeed if a range inhibitor is active. Check for illumination of the RANGE INHIBIT indicator.

## N (Neutral)

The neutral position places the transmission in neutral. This position is used when starting the engine and for stationary operation.

## WARNING

**When in neutral, failure to apply vehicle brake systems may allow the vehicle to move unexpectedly, possibly causing property damage or personal injury.**

When neutral is selected, the vehicle service brakes, parking brake, or emergency brake must be applied. Selecting neutral does not apply vehicle brakes unless

# Transmissions

---

an auxiliary system to apply the parking brake is installed.

## **WARNING**

**Coasting in neutral can cause an accident, possibly resulting in severe personal injury or death.**

Do not let the vehicle coast in neutral. If the vehicle is allowed to coast in neutral, the engine brake will not work and you could lose control of the vehicle.

## **CAUTION**

**Coasting in neutral can cause severe transmission damage.**

**D (Drive)**

## **WARNING**

**When going downhill, use a combination of downshifting, braking, and other retarding devices to control vehicle speed and the engine's rated governed speed. Failure to do so could reduce vehicle braking, possibly causing loss of vehicle control and resulting in personal injury or property damage.**

In the drive position, the transmission will initially go into first range when drive is selected. As vehicle speed increases, the transmission will upshift automatically through each available range up to fourth range or fifth range. As the vehicle slows, the transmission will downshift automatically.

When going downhill, downshift to a lower transmission range to increase engine braking and to help maintain control. The transmission has a feature to prevent automatic upshifting above the lower range selected. However, during downhill operation, the transmission may upshift to the next higher range, if the engine is exceeding its governed speed in the lower range.

## **CAUTION**

**Do not idle in drive for more than 5 minutes. Extended idling in drive may cause transmission overheating and damage. Always select PB (auto-apply parking brake) or P (park) if time at idle is longer than 5 minutes.**

NOTE: The shift into drive may not succeed if a range inhibitor is active. Check for illumination of the RANGE INHIBIT indicator.

### **4 and 3 (Fourth and Third Ranges, optional)**

Use the fourth or third range for city traffic and for braking on steep downgrades.

## 3 and 2 (Third and Second Ranges, standard)

Use the third or second range for heavy city traffic and for braking on steeper downgrades.

## 1 (First Range)

Use first range when pulling through mud or deep snow, when maneuvering in tight spaces, or when driving up or down very steep grades. First range provides the vehicle with its maximum driving torque and maximum engine braking effect.

## General Information, MD Series

MD-series automatic transmissions have six forward speeds and one reverse speed. See [Fig. 5.18](#). These transmissions have electronic shift controls that can be programmed to allow the use of different numbers of geared speeds. For instance, the transmission can be programmed to operate as a four-speed, five-speed, or six-speed unit in the "primary" shift mode. If needed, a "secondary" shift mode can be programmed to provide another shift configuration to optimize vehicle use under different operating conditions. To activate a secondary shift mode, or other special function programmed into the electronic control unit (ECU), depress the mode button. "Mode On" is displayed in the indicator panel just above the push buttons. A label just above the Mode button identifies the special function.

**NOTE:** Each time a push button is depressed on the shift selector, a short beep will be heard. This indicates that the ECU has received input to change operation.

The MD-series transmission system is designed to warn the driver of transmission malfunctions. The driver of a vehicle equipped with these transmissions should know the extent of the warning system in order to safely operate the vehicle. See [Chapter 3](#) for information on the warning system.

## Safety Precautions, MD Series



**Do not leave the vehicle unattended with the engine running. If you leave the vehicle and the engine is running, the vehicle can move suddenly, which could result in personal injury or property damage.**

On vehicles with MD series transmissions, do the following steps if you have to leave the cab with the engine running (for example, when checking the transmission fluid):

1. Bring the vehicle to a complete stop using the service brake.
2. Put the transmission in N (neutral).

# Transmissions

---

3. Ensure that the engine is at low idle rpm (below 1000).
4. Apply the parking brake and emergency brakes, and make sure they are properly engaged.
5. Check the rear tires and take any other steps necessary to keep the vehicle from moving.

## Operation, MD Series



### CAUTION

**The engine should never be operated for more than 30 seconds at full throttle with the transmission in gear and the output stalled. Prolonged operation of this type will overheat the transmission fluid and will result in severe damage to the transmission.**

1. Start the engine, then check the digital display on the push button shift selector. Under Select at the top of the unit, the display should always show the primary shift mode. Under Monitor, the gear the transmission is in should be displayed.



### WARNING

**Never shift from neutral (N) to drive (D) or reverse (R) at engine speeds above idle. The vehicle will**

**lurch forward or rearward; this could cause property damage and personal injury.**

2. Use reverse (R) to back the vehicle. Completely stop the vehicle before shifting from a forward gear to reverse or from reverse to forward. There is only one reverse gear.
3. Select drive (D) for all normal driving conditions. The vehicle will start out in 1st gear, and as speed increases, the transmission will upshift through each gear automatically. As the vehicle slows down, the transmission will downshift to the correct gear automatically.

The pressure of your foot on the accelerator pedal influences the automatic shifting. When the pedal is fully depressed, the transmission will automatically upshift near the governed speed of the engine. A partially depressed position of the pedal will cause the upshifts to occur at a lower engine speed.

4. Occasionally the road, load, or traffic conditions make it desirable to restrict the automatic shifting to a lower range. The lower the gear range, the greater the engine braking power.

Use the up or down arrow buttons on the shift selector to reach the desired gear. The Select indicator will display your choice, and the Monitor indicator will show the selected gear once it is reached.



NOTE: In the lower gear ranges, the transmission will not upshift above the highest gear selected unless the engine governed speed is exceeded.

5. Engage neutral (N) and apply the parking brake when the vehicle is parked with the engine running.



**Do not allow the vehicle to coast in neutral. This can result in severe transmission damage. Also, no engine braking is available.**

## Chrysler Automatic Transmissions

### General Information, Chrysler

Chrysler four-speed automatic transmissions have six shift positions on the selector lever (see Fig. 5.19). The selector lever is lighted for better visibility at nighttime. Each forward shift position provides a range of forward gears that are selected automatically according to the speed of the vehicle, engine temperature, and throttle position.

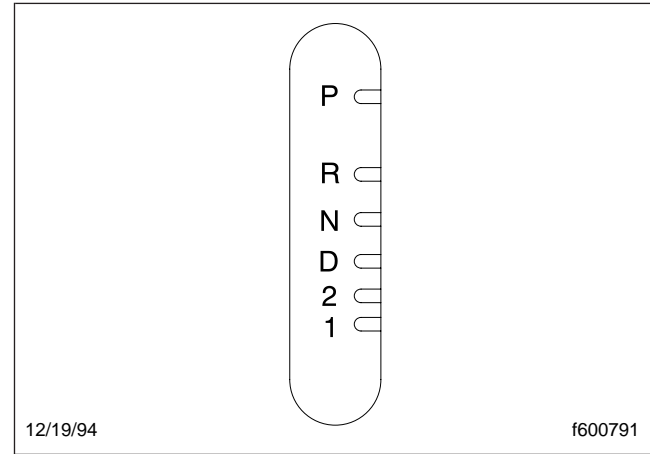

Fig. 5.19, Shift Indicator Lever

### Operation, Chrysler

**IMPORTANT:** Do not race the engine when shifting from park (P) or neutral (N) into a drive gear range.

1. Use park (P) to lock the transmission as a supplement to the parking brake. Apply the parking brake first, then shift into park. The engine may be started in this position.

# Transmissions

## ⚠ CAUTION

**Never use park when the vehicle is in motion. This can result in severe transmission damage.**

2. Use reverse (R) to back the vehicle. Completely stop the vehicle before shifting from a forward gear to reverse or from reverse to forward. There is only one reverse gear.
3. Engage neutral (N) and apply the parking brake when the vehicle is parked with the engine running. The engine may be started in this position.

## ⚠ CAUTION

**Do not allow the vehicle to coast in neutral. This can result in severe transmission damage. Also, no engine braking is available.**

4. Select drive (D) for all normal driving conditions. The vehicle will start out in 1st gear, and as speed increases, the transmission will upshift through each gear automatically. As the vehicle slows down, the transmission will downshift to the correct gear automatically.

Fourth gear (overdrive) can be locked out by pressing the O/D OFF switch (for more information, see Overdrive Operation). See [Fig. 5.20](#).

Occasionally the road, load, or traffic conditions make it desirable to restrict the automatic shifting to a lower range. The lower the gear range, the greater the engine braking power.

5. Use 2nd (2) for slow driving in heavy city traffic, or on mountain roads when more precise speed control is desirable. Use it also for climbing long grades and for engine braking when descending moderately steep grades. To prevent excessive engine speed, do not drive faster than 45 mph (72 km/h) in this range.

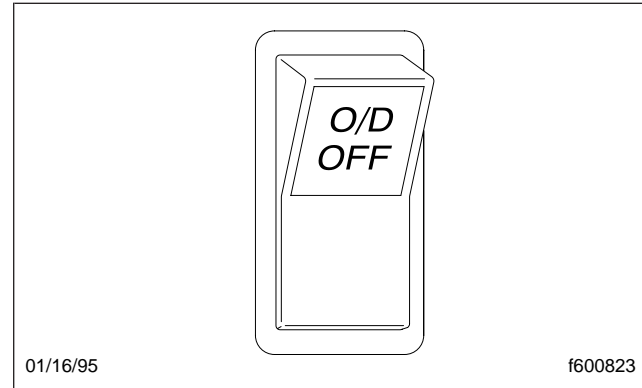

**Fig. 5.20, Overdrive OFF Switch**

6. Use 1st (1) for climbing very steep grades and for engine braking at low speeds when going downhill. To prevent excessive engine speed, do not drive faster than 25 mph (40 km/h) in this range.

NOTE: In the lower gear ranges, the transmission will not upshift above the highest gear selected unless the engine governed speed is exceeded.

## Overdrive Operation

Overdrive is an electronically-controlled 4th forward gear. The transmission automatically shifts from drive into overdrive when:

- The selector lever is in drive (D);
- The engine coolant has reached normal operating temperature;
- The vehicle speed is above approximately 30 mph (50 km/h);
- The O/D OFF switch is not lighted.

The transmission downshifts from overdrive to drive when the accelerator pedal is fully depressed at vehicle speeds above approximately 35 mph (55 km/h).

Overdrive can be locked out by pressing the O/D OFF switch located on the instrument panel. A light in the switch button indicates that overdrive is turned off. To reactivate overdrive, press the switch again. The light

will go out, indicating the overdrive feature is active. The transmission now will automatically switch into overdrive whenever conditions are right.

Overdrive is automatically selected every time the engine is started. If desired, the O/D OFF switch must be selected again, after start-up.

## When To Lock Out Overdrive

Lock out overdrive when driving in hilly areas, towing a trailer, carrying a heavy load, or whenever frequent shifting is necessary. This will improve performance and reduce the possibility of an overheated engine, or damage to the transmission caused by excessive shifting.

## Torque Converter Clutch

The torque converter clutch is a feature designed to improve fuel economy. This clutch within the torque converter engages automatically at calibrated speeds. This may result in a slightly different feeling or response during normal operation in high gear. When vehicle speed drops, or when the vehicle downshifts into 2nd gear during acceleration, the clutch automatically disengages.

NOTE: If the vehicle has not been driven for several days, the first few seconds of operation may seem sluggish. Fluid has partially drained from the torque converter. This is a normal condition and

# Transmissions

---

does not cause any damage to the transmission. Allow at least five seconds for the fluid to refill.

## Aisin A581 Automatic Transmission

### General Information, Aisin

The Aisin A581 automatic transmission has five forward gear selections and one reverse gear selection. The automatic transmission is comprised of a three-element, single-stage and two-phase type torque converter which is a planetary gear unit comprised of three sets of wet multiple disk clutches, three sets of multiple disk brakes, and three sets of planetary gears; an oil pressure control system containing an oil pump and valves; and a computer that automatically shifts gear positions based on vehicle running conditions, such as speed and load.

### Operation, Aisin

Gear shift and lockup operation of the A581ATM is controlled by computer and is based on vehicle running conditions, such as throttle opening rate, speed, and gear positions. The A581ATM is provided with POWER/ECONOMY pattern modes. Through this switch, gear shift and lockup timings can be selected based on load and road surface conditions.

### Electronic Control Unit (ECU)

The ECU processes data input from sensors and switches, determines gear shift and lockup timing, and transmits signals to the solenoids.

### Speed Sensor

The speed sensor detects running speed (transmission output shaft revolution rate) and transmits speed signals to the ECU.

### Turbine Revolution Sensor

The turbine revolution sensor detects running speed (transmission output shaft revolution rate) and transmits turbine revolution signals to the ECU.

### Oil Temperature Sensor

The oil temperature sensor detects oil temperatures in the oil pan and transmits oil temperature signals to the ECU.

### Neutral Start Switch

The neutral start switch detects shift positions (R, N, D, 3, 2, and L) specified when the driver positions the shift selector lever and transmits corresponding signals to the ECU.

## Shift Solenoid

The solenoids select the optimum oil path of the valve body in the transmission based on ECU signals to control gear change and lockup operation.

## Oil Temperature Switch

When the transmission oil temperature rises abnormally, the oil temperature switch activates to light the oil temperature warning lamp on the driver's instrument panel.

## Power Selector Switch

The power selector switch includes two modes: power and economy. Drivers can select a running mode by depressing the power selector switch. This switch transmits information to the ECU gear shift and lockup timing signals appropriate for each running mode.

## Over Drive (O/D)

The O/D switch controls O/D status. Gear shift to fifth is prevented when O/D is switched off.

## Range Selections

The following information explains how the transmission range selections function when selected. See [Fig. 5.21](#).

### Range 3

When the operator selects range 3, the transmission will only shift between first, second, and third gears.

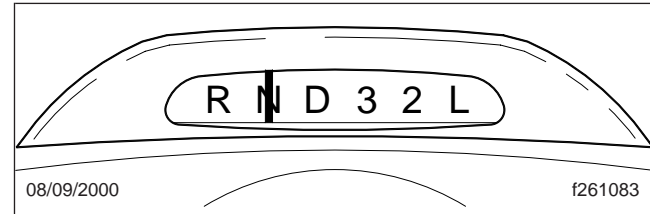

**Fig. 5.21, Column Shift Indicator Window**

If the operator selects range 3 while the vehicle is currently in fourth or fifth gear, the transmission will position for a shift to third gear.

During low-speed operation, the gear position is directly shifted to third gear.

During high-speed running, the transmission will position for a downshift to the next available lower gear until the speed is sufficiently reduced to prevent overrun of the engine and the transmission can safely shift into third gear.

### Range 2

When the operator selects range 2, the transmission will only shift between first and second gears. If the operator selects range 2 while the vehicle is currently in third, fourth or fifth gear, the transmission will position for a shift to second gear.

# Transmissions

---

During low-speed operation, the gear position is directly shifted to second gear.

During high-speed running, the transmission will position for a downshift to the next available lower gear until the speed is sufficiently reduced to prevent overrun of the engine and the transmission can safely shift into second gear.

## Range L

When the operator selects range L, the transmission will remain in first gear and will not upshift. If the operator selects range L while the vehicle is currently in second, third, fourth or fifth gear, the transmission will position for a shift to the low range.

During low-speed operation, the gear position is directly shifted to low range.

During high-speed running, the transmission will position for a downshift to the next available lower gear until the speed is sufficiently reduced to prevent overrun of the engine and the transmission can safely shift into low range.

## Clutches, Rear Axles, and Steering

Clutches .....	6.1
Rear Axles .....	6.4
Steering System .....	6.9

# Clutches, Rear Axles, and Steering

---

## Clutches

### Eaton Valeo Clutch Break-In

With a new or newly installed Eaton Valeo clutch, the clutch may slip for a short time while the friction surfaces break-in. However, allowing the clutch to slip for more than two seconds can severely damage the clutch disc, pressure plate, and the flywheel.

During initial operation of a new vehicle or a vehicle with a new clutch, check for clutch slippage during acceleration. If the clutch slips, decelerate until the clutch does not slip. Allow the clutch to cool 15 to 30 seconds, and then gradually accelerate again. If the clutch continues to slip, repeat the procedure. If necessary, repeat the procedure up to five times. If the clutch slips after five attempts, stop the vehicle. Allow the clutch to cool for at least one hour. Notify your Freightliner dealer of the problem.



## CAUTION

**Do not allow sustained slippage of the clutch. This could severely damage the clutch disc, pressure plate, or flywheel. Damage caused by clutch slippage due to improper break in is not warrantable.**

## General Information

The major reason clutches wear out too soon is excessive heat. Clutches are designed to absorb and dissipate more heat than encountered in typical operation. The temperatures developed in typical operation will not break down the clutch friction surfaces. However, if a clutch is slipped excessively, or required to do the job of a fluid coupling, high temperatures develop quickly and destroy the clutch. Temperatures generated between the flywheel, driven discs, and pressure plates can be high enough to cause the metal to flow and the friction facing material to char and burn.

Slipping and excessive heat are practically nonexistent when a clutch is fully engaged. But during the moment of engagement, when the clutch is picking up the load, it generates considerable heat. An incorrectly adjusted or slipping clutch will rapidly generate sufficient heat to destroy itself.

The most important items that a driver should be aware of to ensure long service life of the clutch include: starting in the right gear, recognizing clutch malfunctions, and knowing when to adjust a clutch.



# Clutches, Rear Axles, and Steering

---

## Clutch Operation

### Starting the Vehicle in the Correct Gear

To drive forward, always start in first gear. After the clutch is fully engaged, the engine should be accelerated to the correct rpm for the upshift into the next higher gear.

### Gear Shifting Techniques

Many drivers upshift into the next gear, or even skip-shift into a higher gear, before the vehicle has reached the correct speed. This type of shifting is almost as bad as starting off in a gear that is too high, since the engine rpm and vehicle speeds are too far apart, requiring the clutch to absorb the speed difference by generating heat. For transmission operating instructions, see [Chapter 5](#).

The clutch brake (if equipped) is applied by fully depressing the clutch pedal. Its purpose is to stop the transmission gears from rotating in order to engage the transmission gears quickly in making an initial start.



**Never apply the clutch brake when making downshifts or upshifts. The clutch pedal should never be fully depressed before the transmission is put in neutral. If the clutch brake is applied with the trans-**

mission still in gear, a reverse load will be put on the gear. At the same time, it will have the effect of trying to stop or decelerate the vehicle with the clutch brake. Rapid wear of friction discs will take place necessitating frequent replacement. Considerable heat will be generated, which will be detrimental to the release bearings and transmission front bearings.

### Vehicle Overload, or Overloading the Clutch

Clutches are designed for specific vehicle applications and loads. These limitations should not be exceeded.



**Overloading will not only result in damage to the clutch, but also to the entire power train.**

### Riding the Clutch Pedal

Riding the clutch pedal is destructive to the clutch, since partial clutch engagement permits slippage, generating excessive heat. Riding the clutch pedal will also put a constant thrust load on the release bearing, which can thin out the lubricant. Release bearing failures can be attributed to this type of misuse.

# Clutches, Rear Axles, and Steering

---

## Holding the Vehicle on an Incline With a Slipping Clutch

A slipping clutch accumulates heat faster than it can be dissipated, resulting in early clutch failures. Never use the clutch as a hill holder.

## Coasting With the Clutch Released (Pedal Depressed) and the Transmission in Gear

Coasting with the clutch released and the transmission in gear can cause high driven disc rpm through multiplication of ratios from the final drive and transmission.



A high driven disc rpm could cause the clutch facing to be thrown off the discs. Ample safety factors are provided for normal operation, but the burst strength of the facing is limited. If this limit is exceeded, flying debris could cause injury to persons in the cab.

## Engaging the Clutch While Coasting

Engaging the clutch while coasting can result in tremendous shock loads and possible damage to the clutch, as well as to the entire drivetrain.

## Reporting Erratic Clutch Operation Promptly

Reporting erratic clutch operation as soon as possible will give maintenance personnel a chance to inspect the clutch components.

On mechanical clutch linkages, free-pedal travel should be included and commented on daily in the driver's report, since clutch free-pedal travel is the maintenance department's guide to the condition of the clutch and the release mechanism.



## CAUTION

Operating the vehicle with incorrect clutch pedal free-travel could result in clutch damage. See *Group 25* of the *Business Class® Trucks Service Manual* for free-pedal adjustment procedures and specifications.

## Clutch Adjustments

Some clutches have an internal adjustment. See the applicable section in *Group 25* of the *Business Class® Trucks Service Manual* for clutch adjustment procedures and specifications.

# Clutches, Rear Axles, and Steering

## CAUTION

Operating the vehicle with the clutch incorrectly adjusted could result in clutch or clutch brake failure.

## Lubrication

The release bearing should be lubricated at frequent intervals. See **Group 25** of the *Business Class® Trucks Maintenance Manual* for intervals and procedures.

## CAUTION

Failure to lubricate the release bearing as recommended could result in release bearing damage and damage to the clutch.

## Hydraulic Clutch Fluid Reservoir Checking

Make sure that the clutch fluid reservoir (**Fig. 6.1**) is full. The reservoir is full when the fluid level is up to the "max" mark. The fluid level must always be above the "min" mark. Use only heavy-duty brake fluid, DOT 3, in the hydraulic-clutch system.

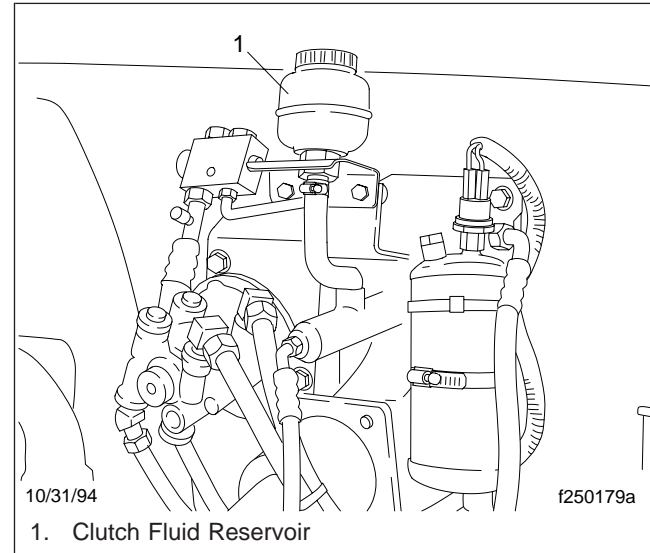

**Fig. 6.1, Check Clutch Fluid Level**

## Rear Axles

### Meritor Single-Drive Axles with Traction Equalizer

Some Meritor single-drive axles are equipped with a traction equalizer that is a load-sensing, self-actuating feature. A traction equalizer provides normal differential

# Clutches, Rear Axles, and Steering

action where traction is good. When one wheel begins to spin faster than the other, clutch plates in the differential housing automatically engage, delivering power to both wheels. There is no operator control with this feature.

A traction equalizer occasionally tends to slip in a jerking motion, producing irregular intervals of sharp noises. This generally occurs when the vehicle is operating at low speeds on fairly sharp turns. This condition, called slip-stick, is corrected by adding a friction modifier to the axle lubricant. This additive tends to reduce the static coefficient of friction to a value equal to, or lower than, the sliding coefficient.

See **Group 35** of the *Business Class® Trucks Maintenance Manual* for additional information on friction modifiers and when to add them to axle lubricants.

## ! CAUTION

**Tire sizes on both rear wheels should be the same on axles equipped with a traction equalizer. If not, excessive wear may occur in the traction equalizer.**

## Meritor Two-Speed Rear Axle

The two-speed rear axle can be used to operate the vehicle in low range when operating off-highway or when starting out with a heavy load on-highway. See

**Fig. 6.2.** After the vehicle is moving on the highway, the axle can be shifted to high range.

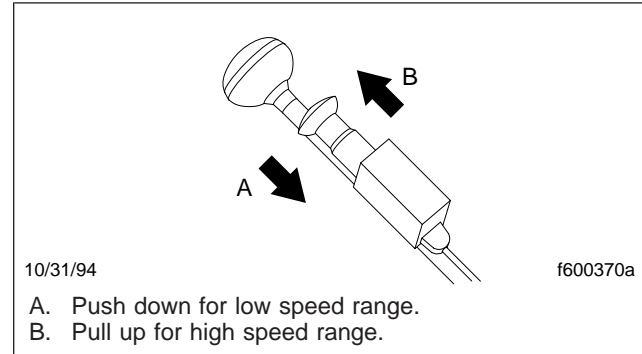

**Fig. 6.2, Range Selection Lever Operation**

To shift the axle to the high range: keep the throttle pedal down, then move the range selection lever to high; release the throttle pedal until the axle shifts, then accelerate.

To shift the axle to low range: keep the throttle pedal down, then move the range selection lever to low; release and then depress the throttle pedal quickly to increase engine rpm. The axle will shift to low range.

**NOTE:** When parking the vehicle, put the axle in the low range with the engine running. Engage the clutch and transmission to be sure the axle has

# Clutches, Rear Axles, and Steering

completed the shift into the low range. Some vehicle motion is needed to ensure engagement of the axle.

## Eaton and Meritor Drive Axles with Main Differential

The Eaton and Meritor main differential lock is a driver-controlled traction device operated from the vehicle cab. A rocker switch allows the driver to lock or unlock the differential. An indicator light in the switch comes on when the differential lock is engaged.

The main differential lock provides maximum traction under slippery conditions. When the differential lock is engaged, the clutch collar completely locks the differential case, gearing, and axle shafts together, maximizing traction of both wheels and protecting against spinout. Under normal traction conditions, do not engage the differential lock.

Operate the axle with differential action between both wheels.



**Be especially careful when driving under slippery conditions, even with the differential locked. Though forward traction is improved, the vehicle**

**can still slip sideways, causing possible loss of vehicle control, personal injury, and property damage.**

## Eaton and Meritor Main Differential Lock Operation

To lock the main differential and obtain maximum traction under slippery conditions, depress the control switch.



**Do not lock the main differential or drive the vehicle with the differential locked at speeds over 25 mph (40 km/h). Never lock the main differential when the vehicle is traveling down steep grades or when the wheels are slipping. This could damage the differential or lead to loss of vehicle control, causing personal injury and property damage.**

If the vehicle is moving, maintain a constant vehicle speed while engaging the differential lock. Briefly let up on the accelerator to relieve torque on the gearing, allowing the differential to fully lock. The indicator light comes on when the differential is fully locked. When the differential is locked, the turning radius will increase because the vehicle understeers. See [Fig. 6.3](#). Drive cautiously and do not exceed 25 mph (40 km/h).

# Clutches, Rear Axles, and Steering

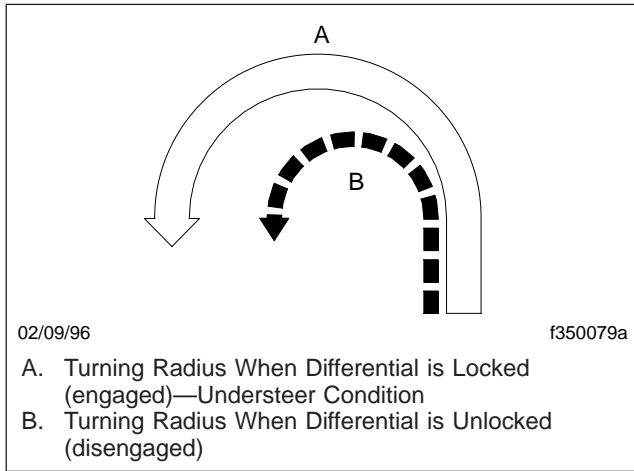

**Fig. 6.3, Turning Radius**

To unlock the main differential, depress the bottom of the control switch. Briefly let up on the accelerator to relieve torque on the gearing, allowing the differential to fully unlock.

When the differential lock disengages, the indicator light will go off.

## Eaton Single Reduction Axles with Controlled Traction Differential

The controlled traction differential system is a differential assembly incorporating a friction plate assembly designed to transfer torque from the slipping wheel to the one with traction. The unit is basically a multiple disc clutch designed to slip above predetermined torque values. This controlled slipping characteristic at higher torque values enables the vehicle to negotiate turns in a normal manner. Resistance to slippage at lower torque values enables the vehicle to maintain an appreciable amount of tractive effort when one wheel encounters relatively poor traction.

A control valve in the cab is actuated by the driver to engage and disengage the controlled traction feature.

Disengaged, the axle has differential action all the time. One wheel will spin independently of the other, if slippery conditions are encountered.

Engaged, wheel slippage and spinout are minimized.

**NOTE:** The controlled traction differential can be engaged at any speed, except during spinout.

## Eaton Two-Speed Tandem Axles

Each axle of the two-speed tandem contains a high range single reduction gear set and a low range double reduction gear set. The operator selects the desired

# Clutches, Rear Axles, and Steering

---

axle range by moving the range preselection lever located on the shifter knob (see [Fig. 6.2](#)).

## Dual Range Two-Speed Tandem Axle Operation with Multispeed Transmissions

NOTE: See [Chapter 5](#), "Transmissions," for detailed information on how to use the range preselection lever. On multispeed transmission applications, the two-speed axle should be used as a dual range. Use the low range when operating off-highway or when starting out with a heavy load on-highway. After the vehicle is moving on the highway, the axle can be shifted to high range.

To shift the axle to the high range, make sure the interaxle differential lockout is disengaged, keep the throttle pedal down, move the range preselection lever to high, release the throttle pedal until the axle shifts, then accelerate.

To shift the axle to the low range, keep the throttle pedal down, move the range preselection lever to low, release and depress the throttle pedal quickly to increase engine rpm. The axle will shift to low range.

NOTE: When parking the vehicle, put the axle in the low range with the engine running. Engage the clutch and transmission to be sure the axle has completed the shift into the low range. Some ve-

hicle motion is required to ensure engagement of the axle.

IMPORTANT: See "Eaton Interaxle Differential Lockout Operation" for precautions that must be taken when shifting axles in relation to the interaxle differential lockout.

## Eaton Interaxle Differential Lockout Operation

Interaxle differential lockout systems include a lockout control valve located in the cab, and an air-operated shift unit mounted on the forward rear axle.

When the interaxle differential lockout control valve is in the LOCK position, the interaxle differential is locked out and the driveshaft becomes a solid connection between the two axles. Power entering the forward axle is also transmitted straight through to the rear axle, so both axles turn together at the same speed. The LOCK position should be used when additional traction is needed.



**Engage the lockout only when stopped or at slow speeds and never when the wheels are spinning. Do not operate the axles on dry pavement with the lockout engaged for prolonged periods. Use only when additional traction is needed under adverse**

# Clutches, Rear Axles, and Steering

road conditions. Disengage the interaxle differential lockout before shifting the axle to a higher range.

When the interaxle differential lockout control valve is in the UNLOCK position, the interaxle differential allows differential action between the axles thereby compensating for different wheel speeds and variations in tire size. Keep the interaxle differential lockout in the UNLOCK position for normal driving on roads where traction is good. On two-speed axles, the interaxle differential must be in the UNLOCK position before attempting to shift the axles out of low or high range.

## Steering System

### General Information

When there is no load on the vehicle, and the front tires are pointed straight ahead, the steering wheel spokes should be at the 4 and 8 o'clock positions, or within 10 degrees of either side. See [Fig. 6.4](#). See **Group 46** of the *Business Class® Trucks Service Manual* for steering adjustment procedures.

### Power Steering System

The power steering system consists of an integral steering gear (which includes a manual steering mechanism, a hydraulic control valve, and a hydraulic power cylinder), hydraulic hoses, power steering pump, reservoir, and other components. The power steering pump,

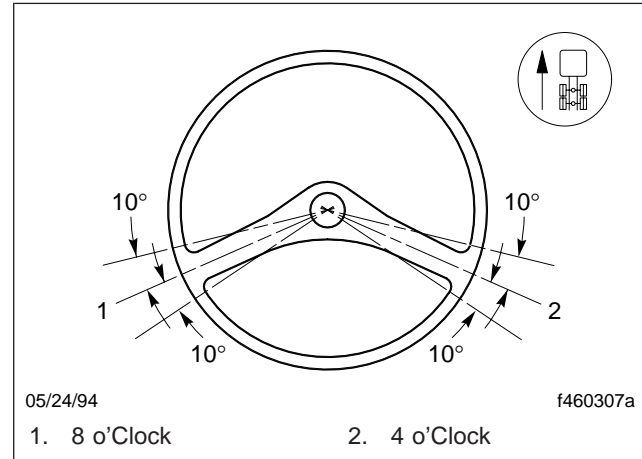

**Fig. 6.4, Steering Wheel Centered**

driven by the engine, provides the power assist for the steering system. If the engine is not running, there is no power assist.

If the power assist feature does not work due to hydraulic fluid loss, steering pump damage, or some other cause, bring the vehicle to a safe stop. Do not drive the vehicle until the cause of the problem has been corrected.



# Clutches, Rear Axles, and Steering

---

**WARNING**

**Driving the vehicle without the power-assist feature of the steering system requires much greater effort, especially in sharp turns or at low speeds, which could result in an accident and possible injury.**

Drivers should use the power available with a power steering system carefully. If the front tires become lodged in a deep chuckhole or rut, drive the vehicle out, instead of using the steering system to lift the tires from the hole. Also, avoid turning the tires when they are against a curb, as this places a heavy load on steering components and could damage them.

# 7

## Brakes

Air Brake System .....	7.1
Hydraulic Brake System .....	7.8

# Brakes

---

## Air Brake System

### General Information

A dual air brake system uses one set of brake controls to operate two independent air brake systems. Each system has its own reservoir, plumbing, and brake chambers. The primary system operates the service brakes on the rear axle; the secondary system operates the service brakes on the front axle. The trailer brakes operate from both systems, or either one if the other malfunctions.



**Do not operate the vehicle with the front brakes backed off or disconnected. Backing off or disconnecting the front brakes will not improve vehicle handling and may lead to loss of vehicle control resulting in property damage or personal injury.**

The rear service brakes will not work if the primary system loses air pressure; however, the front brakes will continue to be operated by secondary system air pressure. The secondary system will also continue to operate the trailer brakes.

The front brakes will not work if secondary system air pressure is lost. The primary system will continue to operate the rear service brakes and trailer brakes.

Before driving your vehicle, allow time for the air compressor to build up a minimum of 95 psi (655 kPa) pressure in both the primary and secondary systems. Monitor the air pressure system by observing the dual system air pressure gauge and the low air pressure warning light and buzzer. The warning light and buzzer shut off when air pressure in both systems reaches 64 to 76 psi (441 to 524 kPa).

The warning light and buzzer come on if air pressure drops below 64 to 76 psi (441 to 524 kPa) in either system. Although the vehicle's speed can be reduced using the foot brake control pedal, either the front or rear service brakes will not be operating, causing a longer stopping distance. If this happens, check the air system pressure gauges to determine which system has low air pressure. Bring the vehicle to a safe stop, and have the air system repaired before continuing.

On tractor-trailer vehicles, if both the primary and secondary systems become inoperative, the trailer service brakes or spring parking brakes will automatically apply when air pressure drops below 35 to 45 psi (241 to 310 kPa). The tractor spring parking brakes will automatically apply when air pressure drops below 20 to 30 psi (138 to 207 kPa). On straight trucks, spring parking brakes will apply when air pressure drops below 20 to 30 psi (138 to 207 kPa). Do not wait for the brakes to apply automatically. When the warning light and buzzer first come on, immediately bring the vehicle to a safe

stop. Before continuing operation of the vehicle, correct the cause of the air loss.

 **WARNING**

**Do not drive the vehicle with the parking brakes caged; there would be no means of stopping the vehicle and this could result in serious personal injury or vehicle damage. Before caging the spring parking brakes, make the connection to a towing vehicle or chock the tires.**

NOTE: Before a vehicle with insufficient system air pressure can be moved, the spring parking brakes must be released by applying an external air source at the gladhands, or by manually caging (manually releasing) the parking brake springs.

After correcting the brake system problem, uncage the spring parking brakes before resuming normal vehicle operation.

## Operation

Before driving the vehicle, secure all loose items in the cab so that they will not fly forward during a full brake application. Make sure that all occupants are wearing seat belts.

**IMPORTANT:** An air brake proportioning system is used in tractor air brake systems. When operating in bobtail mode, the rear brake chambers (whose axle load has been greatly reduced) receive less air pressure, while the front axle brake chambers receive full normal air pressure. This results in a different brake pedal feel, as the pedal seems to require more travel and/or effort to slow or stop the vehicle. However, the air brake proportioning system actually improves vehicle control when the tractor for the bobtail mode of operation. When the tractor is towing a trailer, the rear brake chambers will receive full (normal) air pressure.

During normal brake stops, push the foot brake control pedal until braking action slows down the vehicle. Increase or decrease the pressure on the pedal so that the vehicle comes to a smooth, safe stop. As the vehicle nears full stop, push the clutch pedal in and shift the transmission into neutral. Apply the spring parking brakes if the vehicle is to be parked.

**IMPORTANT:** If service brakes are totally lost but full system air pressure is available, immediately use the parking brake control valve (yellow knob) to bring the vehicle to a complete stop in the safest available location.

The yellow diamond-shaped knob ([Fig. 7.1](#)) on the control panel actuates the parking brake valve. Pulling out

# Brakes

the knob applies both the tractor and the trailer spring parking brakes, and automatically causes the trailer air supply valve knob to pop out.

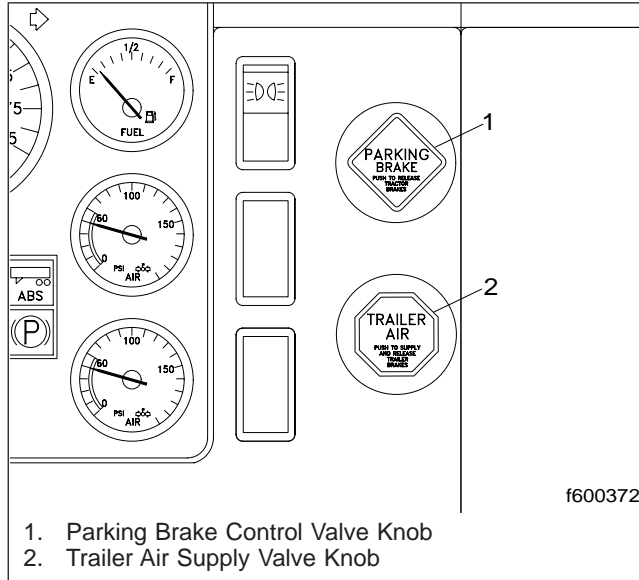

**Fig. 7.1, Parking Brake Control Valve and Trailer Air Supply Valve Knobs (typical location)**

The red octagonal knob (**Fig. 7.1**) on the control panel actuates the trailer air supply valve. After the vehicle's

air hoses are connected to a trailer, and the pressure in both air systems is at least 65 psi (448 kPa), the red knob must be pushed in. It should stay in to charge the trailer air supply system and to release the trailer spring parking brakes; it must be pulled out before disconnecting a trailer. It must also be pulled out when operating a vehicle without a trailer. If pressure in both air systems drops to 35 to 45 psi (241 to 310 kPa), the red knob automatically pops out, exhausting the trailer air supply and applying the trailer service or spring parking brakes.



## CAUTION

**Don't use the spring parking brakes if the service brakes are hot, such as after descending a steep grade. Also, don't use the spring parking brakes during freezing temperatures if the service brakes are wet. To do so could damage the brakes if hot or, cause them to freeze during cold weather.**

If the brakes are wet, drive the vehicle in low gear and lightly apply the brakes to heat and dry them.

Allow hot brakes to cool before using the spring parking brakes.

If the trailer is not equipped with spring parking brakes, pulling out the yellow knob applies the tractor spring parking brakes and the trailer service brakes. When the tractor and trailer parking brakes (or trailer service

brakes) are both applied, the trailer brakes can be released by pushing in the red knob, leaving the tractor parking brakes applied. Air pressure in the primary or secondary reservoir must be at least 64 psi (447 kPa) before the tractor spring parking brakes, or the trailer service or spring parking brakes, can be released.

On trailers not equipped with spring parking brakes, chock the trailer tires before disconnecting the truck or tractor when parking just the trailer. When parking a truck or tractor with a trailer (combination vehicle), and when the trailer is not equipped with spring parking brakes, apply the truck or tractor spring parking brakes.

## **WARNING**

**Do not use the trailer air supply for parking trailers not equipped with spring parking brakes. This applies the trailer service brakes only. As air bleeds from the trailer brake system, brake application is lost. This could allow the unattended vehicle to roll away, possibly resulting in serious personal injury or death.**

## **CAUTION**

**Never apply the service and spring parking brakes simultaneously. To do so transmits excessive input force to the brake components, which could dam-**

**age or cause eventual failure of brake actuating components.**

## Meritor WABCO® Antilock Braking System (ABS), Air Brake Systems

The Meritor WABCO® Antilock Braking System (ABS) is an electronic wheel speed monitoring and control system that works with the air brake system. ABS passively monitors vehicle wheel speed at all times, but *controls* wheel speed during an emergency or reduced-traction stop. In normal braking applications, the standard air brake system is in effect.

**IMPORTANT:** For proper ABS system operation, do not change tire sizes. The sizes of the tires installed during production are programmed into the electronic control unit (ECU). Installing different sized tires could result in a reduced braking force, leading to longer stopping distances.

ABS uses sensors reading signal-generating tone rings in the wheel hubs of each sensed axle. The sensors transmit vehicle wheel speed information to an ECU located behind the passenger seat. The control unit's main circuit interprets the speed sensor signals and calculates wheel speed, wheel retardation, and a vehicle reference speed. If the ECU calculates that a wheel is about to lock, the main circuit signals the appropriate

# Brakes

---

solenoid control valve to reduce braking pressure. During emergency braking, the solenoid control valve regulates air pressure supply in each brake chamber to avoid locking that wheel.



## CAUTION

**An accumulation of road salt, dirt or debris on the ABS tone wheels and sensors can cause the ABS warning light to come on. If the ABS light does come on, the tone rings and sensors should be inspected for corrosion and serviced if necessary. The service should include cleaning of the tone rings and sensors, and if any tone ring on a vehicle shows severe corrosion, all tone rings on that vehicle should be replaced.**

**During winter months in areas where corrosive materials are used on the highways, periodically clean the underside of the vehicle including the tone rings and sensors to ensure proper ABS function and protect the components from corrosion. Clean more frequently when unusually corrosive chemicals are being used.**

The ECU also has a safety circuit which constantly monitors the wheel sensors, solenoid control valves, and the electrical circuitry. If only the tractor has an ABS system, the tractor warning light (TRAC ABS) comes on after turning on the ignition switch. See [Fig. 7.2](#). Once

the vehicle moves faster than about 4 mph (6 km/h), the warning light will go out if all of the tractor's ABS components are working.

A wheel spin indicator light (WHL SPIN) comes on if one of the drive wheels spins during acceleration. See [Fig. 7.2](#). The light goes out when the wheel stops spinning. When the light comes on, partially release the throttle pedal until the light goes out. If slippery road conditions continue, engage the axle lock.



## CAUTION

**Do not engage axle lock while the WHL SPIN light is on. To do so could damage the rear axle. See [Chapter 6](#) for axle lock instructions.**

If the vehicle engine is electronically equipped, an automatic traction control (ATC) system may be installed. On these vehicles, the ATC system automatically reduces wheel spin during reduced-traction starts.

An "ATC Function" switch (if equipped), may be used under more adverse conditions. Turning on this switch illuminates the DEEP SNOW/MUD indicator light ([Fig. 7.2](#)). The ATC system now allows some wheel spin (for example, to help burn through a thin layer of ice) during reduced-traction starts.

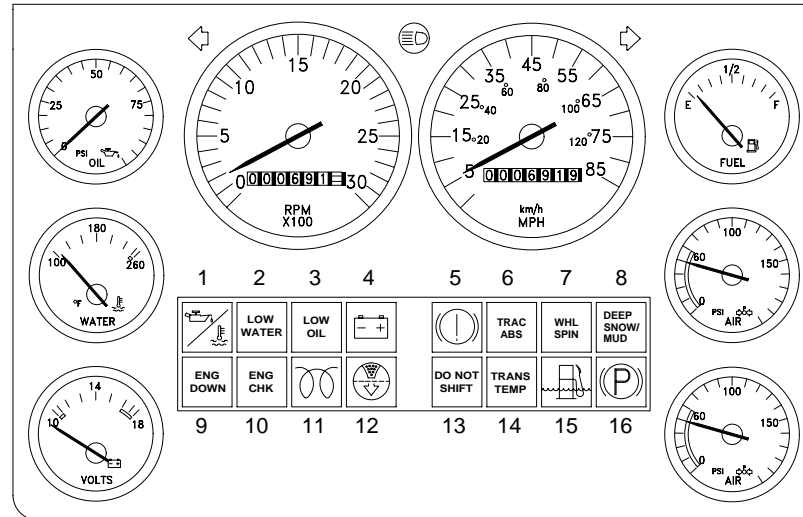

12/20/94

f600373b

- |  |  |   |
|--|--|---|
| 1. Low Oil Pressure/High Water Temperature Warning | 7. Wheel Spin Indicator Light            | 13. Do Not Shift Indicator                                |
| 2. Low Water Level Warning                         | 8. Deep Snow/Mud                         | 14. High Oil Temperature Warning (automatic transmission) |
| 3. Low Oil Level Warning                           | 9. Stop Engine Indicator                 | 15. Water in Fuel/Water Separator Warning                 |
| 4. Alternator Warning Light                        | 10. Engine Check Indicator               | 16. Parking Brake Indicator Light                         |
| 5. Brake System Warning                            | 11. Cold Start Manifold Heater Indicator |   |
| 6. Tractor ABS Warning Light                       | 12. Air Cleaner Restriction Indicator    |   |

**Fig. 7.2, Warning and Indicator Lights**



# Brakes

---

**IMPORTANT:** If the vehicle is equipped with an electronic engine and ATC, turning on the diagnostic switch (ABS CHK) will reduce engine speed to idle, even if the vehicle is being driven. Also, the WHL SPIN light will come on. Turning the ABS CHK switch off will return the engine to normal function.

The Meritor WABCO® ABS system combines one front-axle control channel with either one rear axle (the 4-sensor system), or two rear axles (the 6-sensor system) to form one control circuit. For example, the sensor and solenoid control valve at the left-front axle form a control circuit with the sensor(s) and solenoid valve(s) on the right rear axle(s). If, during vehicle operation, the safety circuit senses a failure in any part of the ABS system (a sensor, solenoid control valve, wiring connection, short circuit, etc.), the tractor warning light (TRAC ABS) comes on and the control circuit where the failure occurred switches to normal braking action. ABS will continue to work on the unaffected system. Even if the ABS system is partially or completely disabled, normal braking ability is maintained. A damaged solenoid control valve or combination solenoid control valve can create an exception; since they are an integral part of the air brake system, normal braking may be impaired or may not work at all.

**IMPORTANT:** If any of the ABS warning lights do not work as described above or come on while

driving, repair the ABS system immediately to ensure full antilock braking capability.

During emergency or reduced-traction stops, fully depress the brake pedal until the vehicle comes to a safe stop; *do not pump* the brake pedal. With the brake pedal fully depressed, the ABS system will control all wheels to provide steering control and a reduced braking distance.

Although the ABS system improves vehicle control during emergency braking situations, the driver still has the responsibility to change driving styles depending on the existing traffic and road conditions. For example, the ABS system cannot prevent an accident if the driver is speeding or following too closely on slippery road surfaces.

## Trailer ABS Lamp Operation

Antilock Braking Systems (ABS) on tractors are designed to communicate with trailer ABS systems, if they are compatible. Compatibility will result in the illumination of the trailer ABS lamp during vehicle start-up and fault detection.

The dash-mounted lamp will operate as follows when a compatible trailer is properly connected to a tractor:

- When the ignition key is turned to the ON position, the trailer ABS lamp will illuminate momentarily, then turn off.

- If the lamp comes on momentarily during vehicle operation, then shuts off, a fault was detected and corrected.
- If the lamp comes on and stays on during vehicle operation, there is a fault with the trailer ABS. Repair the trailer ABS system immediately to ensure full antilock braking capability.

The Trailer ABS lamp will not illuminate unless a compatible trailer is connected to the tractor.

**IMPORTANT:** If a compatible trailer is connected, and the lamp is not illuminating momentarily when the ignition key is turned to the ON position, it is possible that the lamp is burnt out.

## Hydraulic Brake System

### General Information (See Fig. 7.3)

The Bendix hydraulic brake system includes a power booster, master cylinder, reservoir, hydraulic lines, a brake rotor on each wheel hub, and a brake caliper and pad assembly at each rotor.

**IMPORTANT:** Make sure that the fluid level in the master cylinder reservoirs is up to the ridge that surrounds the reservoir. Use only heavy-duty brake fluid, DOT 3, in the hydraulic brake system.

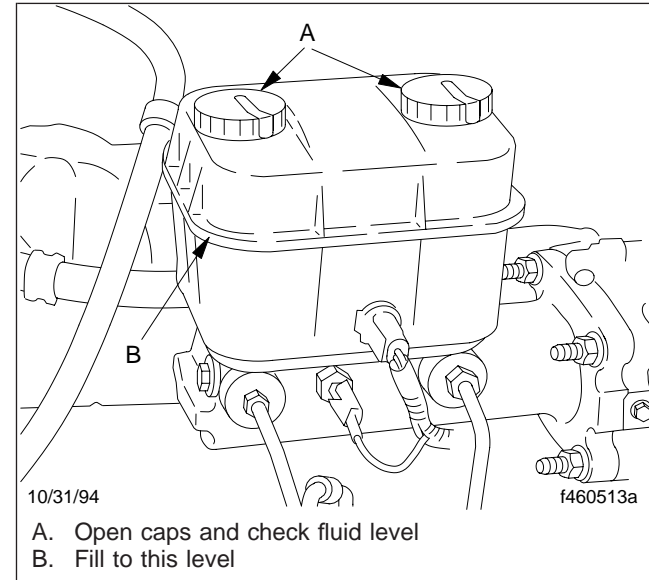

**Fig. 7.3, Hydraulic Brake Reservoir**

The master cylinder controls braking power to the front and rear brakes. The Bendix Hydro-Max® power booster is attached to the rear of the master cylinder and is connected to the power steering system (which provides pressurized power steering fluid). An electrically powered "reserve" pump operates if there is inadequate fluid flow from the power steering pump to the power

# Brakes

---

booster. The brake system warning light comes on if there is a problem within the system. Bring the vehicle to a safe stop and correct the problem before continuing operation of the vehicle. See **Group 42** of the *Business Class® Trucks Service Manual* for hydraulic brake system troubleshooting and adjustment procedures.

## Operation

Before driving the vehicle, secure all loose items in the cab so that they will not fly forward during a full brake application. Make sure that all occupants are wearing seat belts. Check that the brake system warning light is off after releasing the hand brake. If the warning light does not go off, correct the problem before continuing operation of the vehicle.

During normal brake stops, depress the foot brake control pedal until braking action slows down the vehicle. Increase or decrease the pressure on the pedal so that the vehicle comes to a smooth, safe stop. When the forward speed of the vehicle has decreased to almost the idling speed of the engine, push the clutch pedal in, and shift the transmission into Neutral. Apply the hand parking brake if the vehicle is to be parked.

## Meritor WABCO® Antilock Braking System (ABS), Hydraulic Brake Systems

The Meritor WABCO® Antilock Braking System (ABS) is an electronic wheel speed monitoring and control system that works with the hydraulic brake system. ABS passively monitors vehicle wheel speed at all times, but *controls* wheel speed during an emergency or reduced-traction stop. In normal braking applications, the standard hydraulic brake system is in effect.

**IMPORTANT:** For proper ABS system operation, do not change tire sizes. The sizes of the tires installed during production are programmed into the electronic control unit (ECU). Installing different sized tires could result in inaccurate wheel speed signals to the ECU resulting in a reduced braking force, which could lead to longer stopping distances.

ABS includes signal-generating tone wheels and sensors located in the wheel hubs of each sensed axle. The sensors transmit vehicle wheel speed information to the ECU located behind the passenger seat which interprets these signals to calculate wheel speed and a vehicle reference speed. If the calculations indicate wheel lockup, the appropriate control circuit signals the

brake pressure modulator to increase or decrease braking pressure.

---

**CAUTION**

---

**An accumulation of road salt, dirt or debris on the ABS tone wheels and sensors can cause the ABS warning light to come on. If the ABS light does come on, the tone rings and sensors should be inspected for corrosion and serviced if necessary. The service should include cleaning of the tone rings and sensors, and if any tone ring on a vehicle shows severe corrosion, all tone rings on that vehicle should be replaced.**

**During winter months in areas where corrosive materials are used on the highways, periodically clean the underside of the vehicle including the tone rings and sensors to ensure proper ABS function and protect the components from corrosion. Clean more frequently when unusually corrosive chemicals are being used.**

The electronic control unit also has a safety circuit that constantly monitors the wheel sensors, brake pressure modulator, and the electrical circuitry. The dash warning light (TRAC ABS) comes on after the ignition is switched on. Once the vehicle moves faster than about 4 mph (6 km/h), the warning light goes out only if all of the tractor's ABS components are working.

If, during vehicle operation, the safety circuit senses a failure in any part of the ABS system (a sensor, brake pressure modulator, wiring connection, short circuit, etc.), the warning light (TRAC ABS) comes on and the control circuit where the failure occurred is switched to normal braking action. Even if the ABS system is partially or completely inoperative, normal braking ability is maintained. An exception would be if the brake pressure modulator, or hydraulic fluid line is damaged. As these components are an integral part of the hydraulic brake system, normal braking may be impaired or inoperative.

**IMPORTANT:** If any of the ABS warning lights do not work as described above, or come on while driving, repair the ABS system immediately to ensure full antilock braking capability.

During emergency or reduced-traction stops, fully depress the brake pedal until the vehicle comes to a safe stop; *do not pump* the brake pedal. With the brake pedal fully depressed, the ABS system will control all wheels to provide steering control and a reduced braking distance.

Although the ABS system improves vehicle control during emergency braking situations, the driver still has the responsibility to change driving styles depending on the existing traffic and road conditions. For example, the ABS system cannot prevent an accident if the driver is

# Brakes

---

speeding or following too closely on slippery road surfaces.

the ignition key is turned to the ON position, it is possible that the lamp is burnt out.

## Trailer ABS Lamp Operation

Antilock Braking Systems (ABS) on tractors are designed to communicate with trailer ABS systems, if they are compatible. Compatibility will result in the illumination of the trailer ABS lamp during vehicle start-up and fault detection.

The dash-mounted lamp will operate as follows when a compatible trailer is properly connected to a tractor:

- When the ignition key is turned to the ON position, the trailer ABS lamp will illuminate momentarily, then turn off.
- If the lamp comes on momentarily during vehicle operation, then shuts off, a fault was detected and corrected.
- If the lamp comes on and stays on during vehicle operation, there is a fault with the trailer ABS. Repair the trailer ABS system immediately to ensure full antilock braking capability.

The Trailer ABS lamp will not illuminate unless a compatible trailer is connected to the tractor.

**IMPORTANT:** If a compatible trailer is connected, and the lamp is not illuminating momentarily when

## Fifth Wheels

Holland Fifth Wheels .....	8.1
Fontaine Fifth Wheels .....	8.6

# Fifth Wheels

## Holland Fifth Wheels

### General Information

Holland 3500 and FW8 series fifth wheels (**Fig. 8.1**) are bracket-mounted to the tractor frame in a position that best distributes the trailer load over the tractor axles.

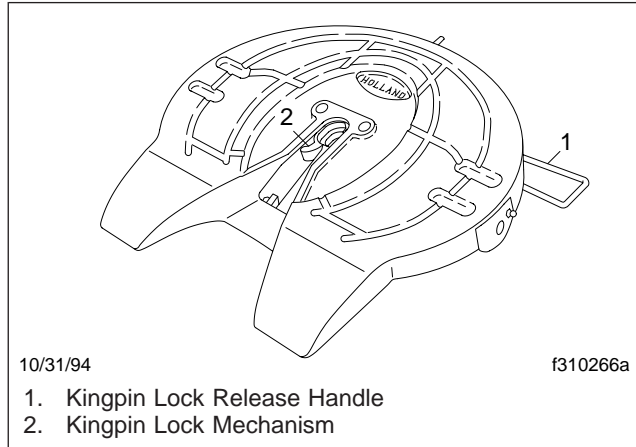

**Fig. 8.1, Holland Fifth Wheel**

The Type "B" kingpin lock mechanism (**Fig. 8.2**) utilizes two spring-loaded lock halves. The final forward motion of the kingpin into the open lock halves forces the locks to close in a 360 degree grip around the shoulder and

neck of the kingpin, positioning sliding yokes between the lock halves and tapered rib members of the fifth wheel understructure. The kingpin can be released only by manually operating the kingpin lock control handle. The adjustment nut will compensate for wear on the lock or kingpin.

The Holland Lockguard (**Fig. 8.3**) is a device that prevents a false lockup, and is used with Type "B" kingpin lock mechanisms. The Lockguard is a spring-tensioned, smooth-surfaced tongue that the kingpin passes over and depresses when entering the lock mechanism. The Lockguard will prevent the locks from engaging before the kingpin fully enters the locks. If the kingpin enters the fifth wheel incorrectly and does not depress the tongue, the locks are unable to close.

The Type "A" kingpin lock mechanism (**Fig. 8.4**) utilizes a single hinged lock and cam arm. The final forward motion of the kingpin into the open lock forces the hinged lock to pivot on a pin and close around the kingpin. The lock is held in place by a spring loaded plunger. The kingpin can be released only by manually operating the release handle. The adjustment nut will compensate for wear on the lock or kingpin.

## Fifth Wheel Locking Operation

### Locking the Fifth Wheel Mechanism

1. Chock the front and rear of the trailer tires to prevent the trailer from moving.

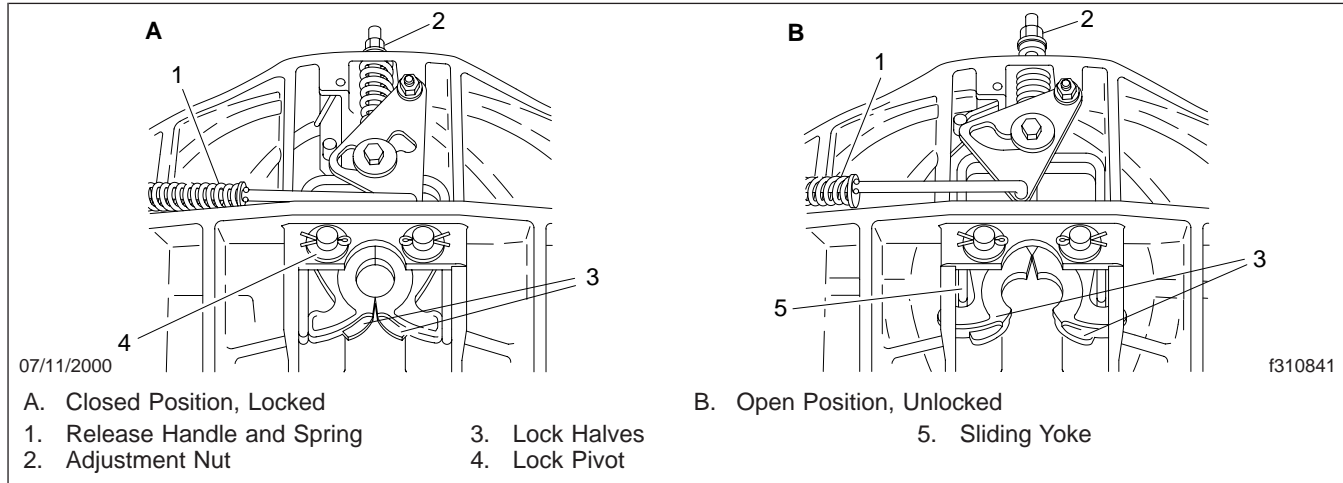

**Fig. 8.2, Type B Kingpin Lock Mechanism (bottom view)**

2. The kingpin lock mechanism must be fully open, and the fifth wheel plate must be completely lubricated with chassis grease. For lubrication instructions, see **Group 31** of the *Business Class® Trucks Maintenance Manual*.



**Keep the fifth wheel plate lubricated to prevent binding between the tractor and trailer. A binding**

**fifth wheel could cause erratic steering and loss of vehicle control, possibly resulting in serious personal injury or death.**

3. Position the tractor so that the fifth wheel lock opening is in line (both vertically and horizontally) with the trailer kingpin. To prevent a false lockup, the kingpin should be in a position to enter the



# Fifth Wheels

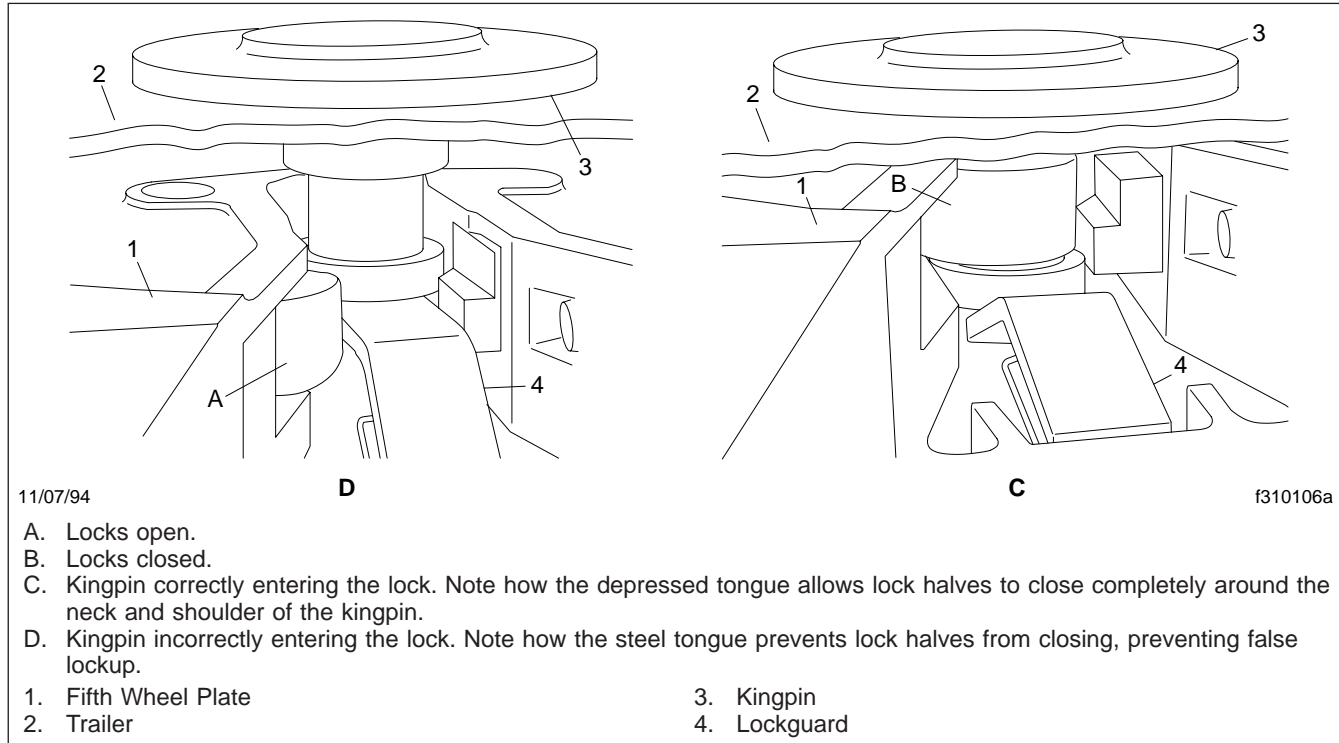

**Fig. 8.3, Lockguard Mechanism (rear view)**

throat of the locking mechanism. See [Fig. 8.3](#). Ad-

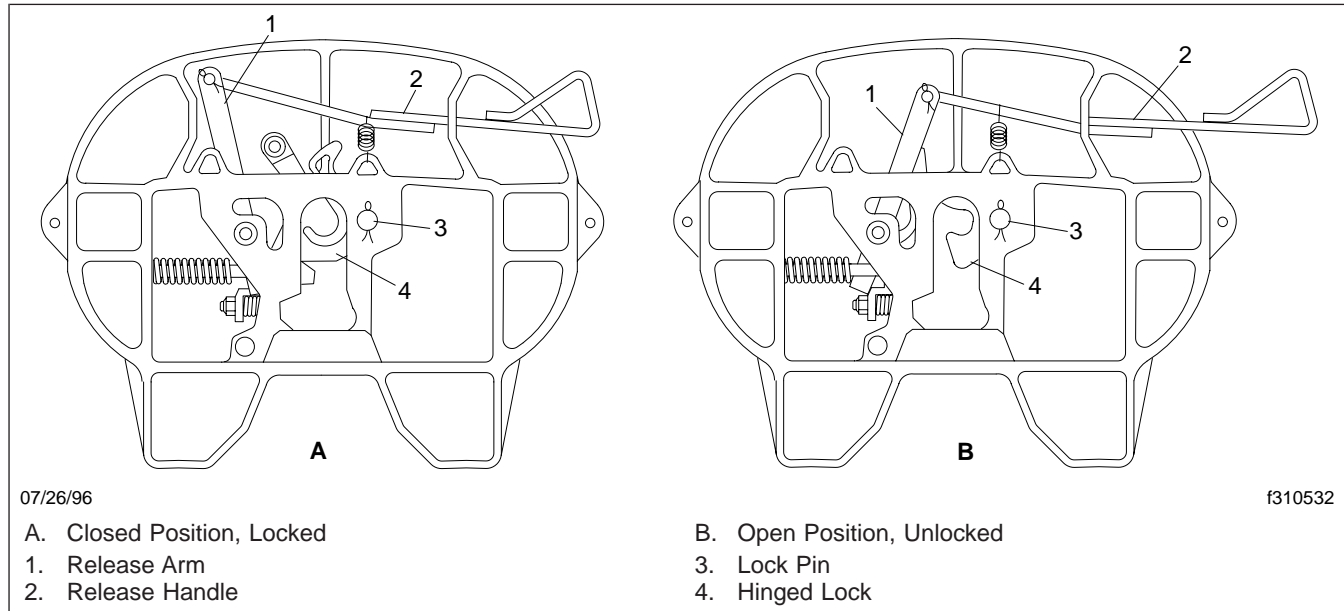

**Fig. 8.4, Type "A" Kingpin Lock Mechanism**

just the trailer landing gear to give enough alignment height so that the fifth wheel picks up the trailer on the fifth wheel ramps.

4. With the fifth wheel lock opening aligned with the trailer kingpin, back the tractor slowly toward the

trailer, making sure that the kingpin correctly enters the throat of the locking mechanism. When the trailer is picked up by the fifth wheel, stop the tractor, then resume slow backward motion until positive lockup occurs.

# Fifth Wheels

---

5. Apply the tractor parking brakes.
6. Make a visual check for proper kingpin lockup. Release the tractor parking brakes.

Test for kingpin lockup by pulling on the trailer against the chocks. Check for correct maximum clearance between the lock halves. If more than 1/8-inch (3.2-mm) clearance exists between the lock halves, the lock must be adjusted. See **Group 31** of the *Business Class® Trucks Service Manual* for adjustment procedures.



**Adjust the locks correctly to a maximum clearance of 1/8 inch (3.2 mm). Incorrect adjustment of the lock could cause a trailer disconnect, possibly resulting in serious personal injury or death.**

7. After lockup is completed, connect the tractor-to-trailer air system lines and electrical cable to the trailer. Take care to prevent dirt or foreign material from entering the air lines.
8. Charge the air brake system with air. Make sure that the air connections do not leak.
9. Retract the trailer landing gear and secure the ratchet handle.
10. Remove the chocks from the trailer tires.

11. The load distribution on the front steering axle and rear drive axle(s) will have a direct effect on the steering control of the vehicle.

Determine the front and rear axle weights by weighing the vehicle on scales designed for this purpose.

The maximum axle weight ratings are shown on the Federal Motor Vehicle Safety Standard (FMVSS) label or Canadian Motor Vehicle Safety Standard (CMVSS) label attached to the left rear door post of the tractor. The desired load on the axle is no less than 80 percent of the maximum axle weight rating, but in no instances should the axle load exceed the maximum axle weight rating given on the FMVSS or CMVSS label.



**Do not overload any tractor axle by improperly loading the trailer. This could cause erratic steering and loss of vehicle control, possibly resulting in serious personal injury or death.**

## Unlocking the Fifth Wheel Lock Mechanism

1. Apply the tractor parking brakes.
2. Pull the trailer air supply valve to cut off the air supply to the trailer.

3. Chock the front and rear of the trailer tires to prevent the trailer from moving.



**Do not use the trailer air supply for parking trailers not equipped with spring parking brakes. This applies the trailer service brakes only. As air bleeds from the trailer brake system, brake application is lost. This could allow the unattended vehicle to roll away, possibly resulting in serious personal injury or death.**

4. Lower the trailer landing gear until the weight is removed from the fifth wheel.
5. Disconnect the tractor-to-trailer air system lines and electrical cable. Plug the air lines to prevent dirt or foreign material from entering the lines.
6. Release the kingpin locking mechanism by pulling the kingpin lock control handle ([Fig. 8.1](#)) to the outward position.
7. Slowly drive the tractor away from the trailer.

## Fontaine Fifth Wheels

### General Information

On Fontaine fifth wheels, kingpin release is accomplished by activating a manual lock control handle located on the left or right side of the fifth wheel. Kingpin lockup occurs when the kingpin is forced into the jaws and the lock control handle moves to the locked position.

On stationary fifth wheels, the fifth wheel top plate is bracket-mounted to the tractor frame in a position that best distributes the trailer load over the tractor axles.

The sliding fifth wheel mount is used with the Fontaine H5092 series, and the Fontaine 6000/7000 No-Slack II series fifth wheels, and is equipped with either an air-operated release slide (HAWB or AWB model), or a manual release slide (HMWS or MWS model). The fifth wheel top plate is mounted on a slide assembly, which is attached to slide rails that are mounted on the vehicle frame. The slide rails permit forward and rearward movement of the slide assembly, allowing for optimum weight distribution over the tractor axles.

Slots are evenly spaced along the slide rails, and retractable tapered wedges are positioned through the slots to hold the fifth wheel in the desired position. See [Fig. 8.5](#) or [Fig. 8.6](#).

# Fifth Wheels

The slide portion of the sliding model may be attached to either an air-operated release slide, or a manual release slide.

The air-operated release slide contains an air cylinder that locks and unlocks the fifth wheel slide. See [Fig. 8.5](#). The air cylinder is activated by a two-position air-control valve in the tractor cab.

The manual release slide contains a slide release pull handle, located on the left side of the fifth wheel, which locks or unlocks the fifth wheel slide. See [Fig. 8.6](#).

## Fifth Wheel Lock Mechanism for Trailer Kingpin

The Fontaine fifth wheel lock mechanism for the trailer kingpin consists of a spring-loaded jaw and a sliding wedge. The jaw and wedge each have a pin permanently attached. The pin on the jaw and the pin on the wedge fit into elongated notches in the lock control handle. The notches in the handle control the limit of movement for both the jaw and wedge. The notches are arranged so that the wedge is actuated first during release of the kingpin.

During lockup, the jaw is moved first with the spring-loaded wedge being allowed to slip into place against the jaw. A timing bracket ensures that the wedge and jaw are moved at the correct time.

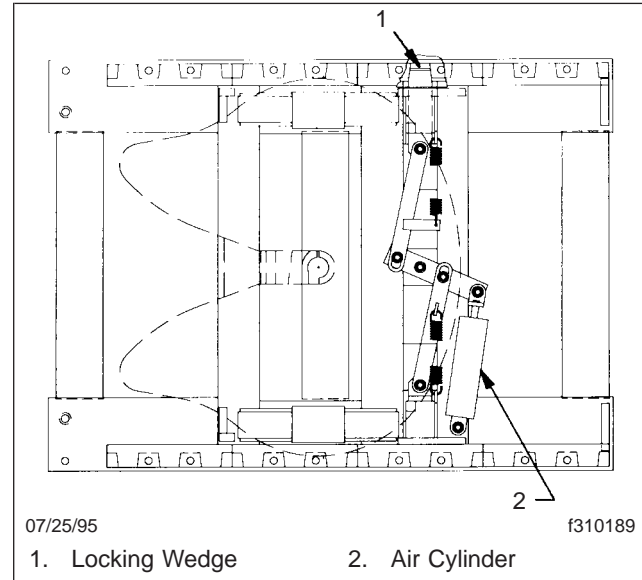

**Fig. 8.5, Air-Operated Sliding Fifth Wheel Mount, AWB Model**

Placing the lock control handle in the unlocked position moves the wedge away from the jaw. This action unlocks the jaw so that it can be moved by the trailer kingpin. When the tractor is moved out from under the trailer, the kingpin moves the jaw until the kingpin is out

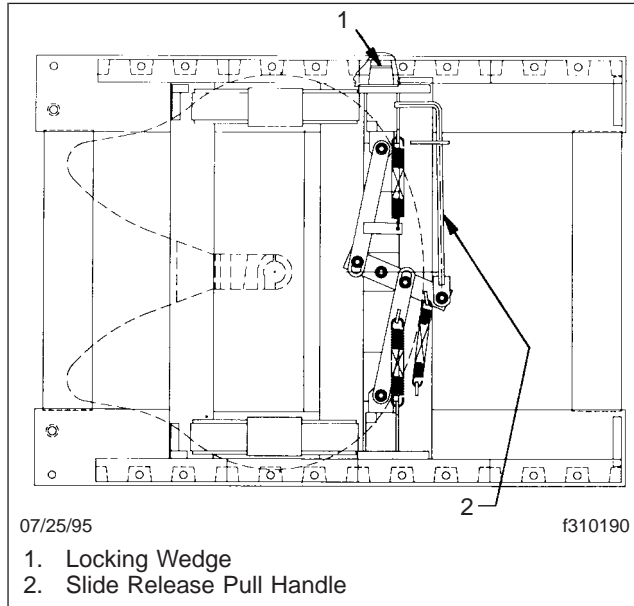

**Fig. 8.6, Manual Release Sliding Fifth Wheel Mount, MWS Model**

of the mechanism. With the jaw in the unlocked position, the lock control handle will remain in the unlocked position until manually moved by the operator.

During coupling (**Fig. 8.7**), the motion of the kingpin entering the jaw will actuate the jaw and wedge. The jaw will move behind the kingpin, followed by the wedge. The purpose of the wedge is to reinforce the jaw and take up slack around the pin. Any wear on the jaw is immediately taken up by the wedge so there is no slack in the connection.

## Fifth Wheel Locking Operation

### Locking the Fifth Wheel Lock Mechanism

#### **CAUTION**

Before attempting to lock or unlock the fifth wheel lock mechanism of a sliding type fifth wheel, the slide release pull handle, if so equipped, and the slide locking wedges must be in the locked position. This prevents the sliding member from moving rapidly to the far forward or rearward position, which could damage the fifth wheel member or kingpin.

1. Chock the front and rear of the trailer tires to prevent the trailer from moving.

#### **WARNING**

Keep the fifth wheel plate lubricated to prevent binding between the tractor and trailer. A binding

# Fifth Wheels

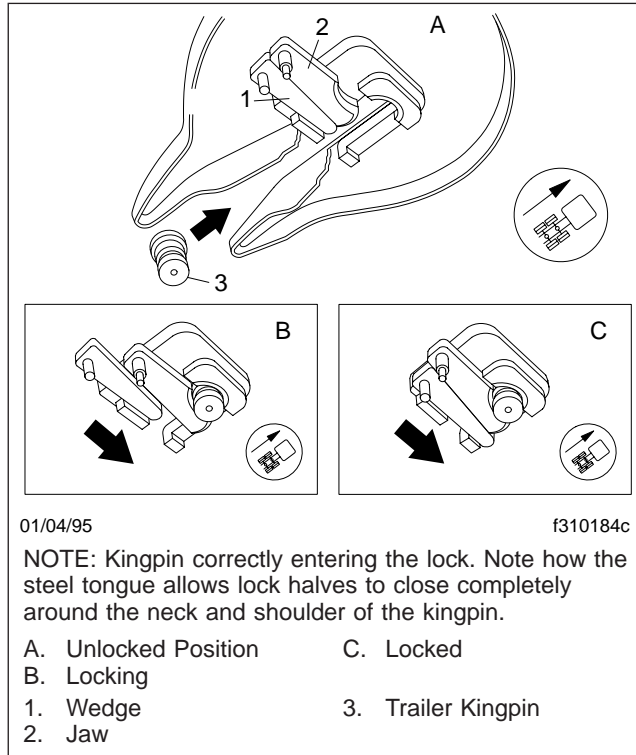
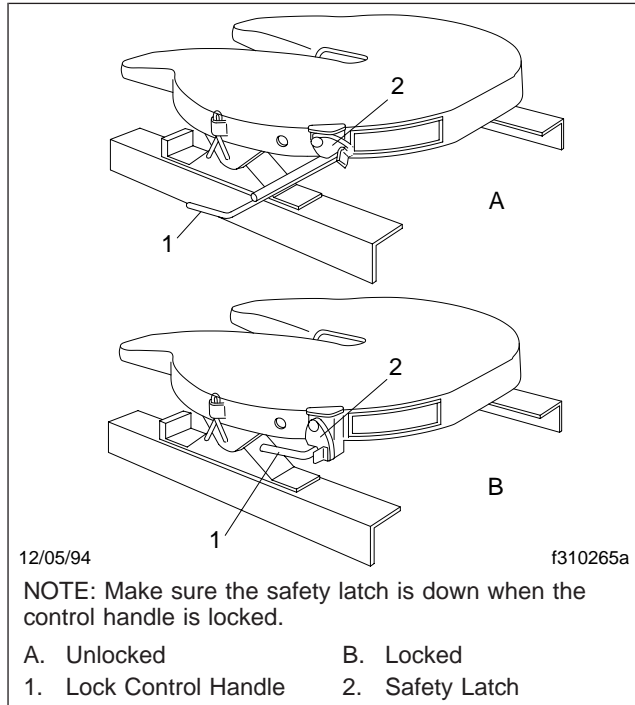

**Fig. 8.7, Fontaine Kingpin Lock Mechanism**

**fifth wheel could cause erratic steering and loss of**

**vehicle control, possibly resulting in serious personal injury or death.**

2. The kingpin lock mechanism must be fully open, the fifth wheel plate must be completely lubricated with chassis grease. For lubrication instructions, see **Group 31** of the *Business Class® Trucks Maintenance Manual*.
3. Position the tractor so that the fifth wheel lock opening is in line (both vertically and horizontally) with the trailer kingpin. The kingpin should be in a position to enter the throat of the locking mechanism, as shown in **Fig. 8.7**. Adjust the trailer landing gear to give enough alignment height for positive kingpin lockup.
4. With the fifth wheel lock opening aligned with the trailer kingpin, back the tractor slowly toward the trailer, making sure that the kingpin enters the throat of the locking mechanism. Continue backward motion until positive lockup occurs.
5. Apply the tractor parking brakes.
6. Make a visual and physical check for positive kingpin lockup. When lockup has occurred, the fifth wheel control handle will have moved to the locked position. Make sure that the safety latch is down over the lock control handle. See **Fig. 8.8**. This will hold the control handle in the locked position.



**Fig. 8.8, Fontaine 5000 Series Fifth Wheel, Locking and Unlocking**

7. Release the tractor parking brakes. Test for kingpin lockup by pulling on the trailer against the chocks.
8. After lockup is completed, connect the tractor-to-trailer air system lines and the electrical cable to the trailer. Take care to prevent dirt or foreign material from entering the air system lines.
9. Charge the air brake system with air. Make sure that the air connections do not leak.
10. With the trailer wheels chocked and the brakes set, check for clearance between the kingpin and the fifth wheel jaws by moving the tractor forward and backward against the locked kingpin. There should be no slack between the tractor and the trailer. If slack is present, uncouple the trailer.

For adjustment instructions, refer to the applicable manufacturer's service information.

## **WARNING**

**Eliminate slack between the trailer and the tractor. Incorrect fifth wheel adjustment could cause the trailer to disconnect, possibly resulting in serious personal injury or death.**

11. Retract the trailer landing gear, and secure the ratchet handle. Remove the chocks from the trailer tires.



# Fifth Wheels

---

12. The load distribution on the front steering axle and rear drive axle(s) will have a direct effect on the steering control of the vehicle.

Determine the front and rear axle weights by weighing the vehicle on scales designed for this purpose.

The maximum axle weight ratings are given on the Federal Motor Vehicle Safety Standard (FMVSS) label or Canadian Motor Vehicle Safety Standard (CMVSS) label attached to the left rear door post of the tractor. The desired load on the axle is no less than 80 percent of the maximum axle weight rating, but in no case should the axle load exceed the maximum axle weight rating given on the FMVSS or CMVSS label.

## WARNING

**Do not overload any tractor axle by improperly loading the trailer. This could cause erratic steering and loss of vehicle control, possibly resulting in serious personal injury or death.**

### Unlocking the Fifth Wheel Lock Mechanism

1. Apply the tractor parking brakes.
2. Pull the trailer air supply valve to cut off the air supply to the trailer.

3. Chock the front and rear of the trailer tires to prevent the trailer from moving.

## WARNING

**Do not use the trailer air supply for parking trailers not equipped with spring parking brakes. This applies the trailer service brakes only. As air bleeds from the trailer brake system, brake application is lost. This could allow the unattended vehicle to roll away, possibly resulting in serious personal injury or death.**

4. Lower the trailer landing gear until the weight is removed from the fifth wheel.
5. Disconnect the tractor-to-trailer air system lines and electrical cable. Plug the air lines to prevent dirt or foreign material from entering the lines.
6. Release the kingpin locking mechanism by lifting the safety latch and pulling the lock control handle to the unlocked position. See [Fig. 8.8](#).
7. Slowly drive the tractor away from the trailer.

## CAUTION

**Before attempting to lock or unlock the fifth wheel lock mechanism of a sliding type fifth wheel, the slide release pull handle, if so equipped, and the**

slide locking wedges must be in the locked position. This prevents the sliding member from moving rapidly to the far forward or rearward position, which could damage the fifth wheel member or kingpin.

## Fifth Wheel Slide Operation

1. Connect the trailer kingpin to the tractor fifth wheel. For instructions, refer to Fontaine "Fifth Wheel Locking Operation," in this chapter.
2. After positive lockup of the fifth wheel lock mechanism has been accomplished, release the slide using one of the following methods:
  - 2.1 For air-operated release models, set the cab-operated control switch (**Fig. 8.9**) to UNLOCK.
  - 2.2 For manual release models, lift the slide release pull handle to disengage it from the guide plate. Then, pull out the handle (**Fig. 8.10**) until it is in the unlocked position and can be positioned against the guide plate to hold it out. The slide release pull handle will stay in the unlocked position until it is manually disengaged from the guide plate.
3. Lower the trailer landing gear just enough to remove the weight from the tractor.

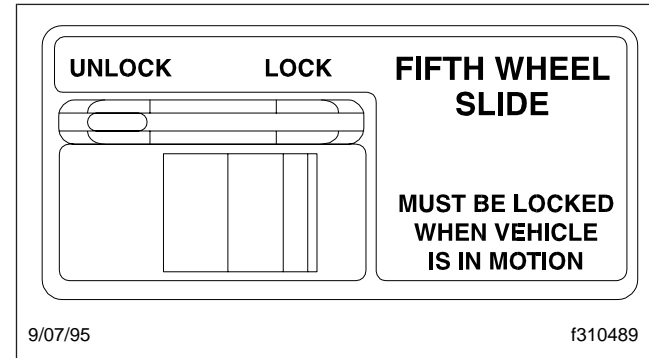

**Fig. 8.9, Cab Control, Fifth Wheel Slide**

4. Pull the trailer air supply valve to cut off the air supply to the trailer.



**Do not use the trailer air supply for parking trailers not equipped with spring parking brakes. This applies the trailer service brakes only. As air bleeds from the trailer brake system, brake application is lost. This could allow the unattended vehicle to roll away, possibly resulting in serious personal injury or death.**

5. Chock the front and rear of the trailer tires to prevent the trailer from moving.

# Fifth Wheels

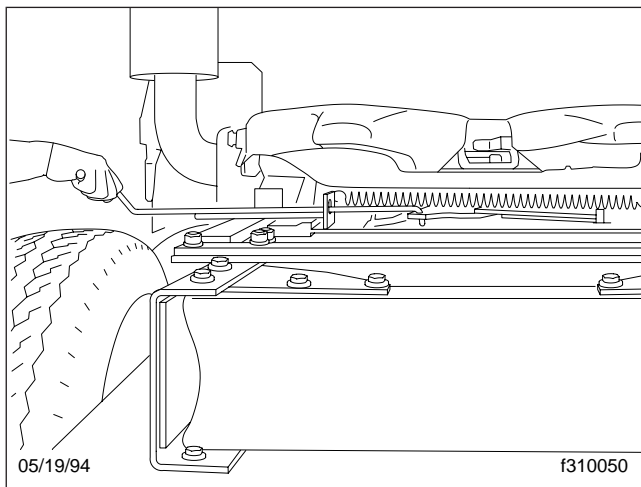

Fig. 8.10, Fontaine Sliding Fifth Wheel Manual Release

## CAUTION

After moving the fifth wheel to the desired position, be sure the trailer landing gear will not, at any time, come in contact with the tractor frame or other components. Make sure that the front of the trailer will not come in contact with the rear of the cab or with other components if they extend beyond the rear of the cab.

6. Slowly move the tractor forward or backward until the fifth wheel is in the desired location.
7. Apply the tractor parking brakes.

NOTE: The fifth wheel may have to be moved slightly to enable the locking wedges to enter the fully locked position.

8. Lock the sliding member in position using one of the following methods:

## WARNING

Physically check to be sure that the locking wedges have seated in the slots. Failure to achieve complete lockup may allow disengagement of the tractor from the trailer, possibly resulting in serious personal injury or death.

- 8.1 For air-operated release models, set the cab-operated slide control switch to LOCK. Visually inspect the locking wedges to make sure that they are fully inserted in the slide rail slots.
- 8.2 For manual release models, disengage the slide release pull handle from the guide plate. The slide release pull handle is spring-loaded in the locked position and will seek the locked position when disengaged from

the guide plate. The fifth wheel may have to be moved slightly to enable the locking wedges to fully enter the locked position. When the slide release pull handle returns to the fully locked position, visually and physically check the locking wedges to make sure they are fully inserted into the slots in the slide rails. Make sure the slide release pull handle is locked in position against the guide plate.

9. The amount of load distribution on the front steering axle and rear drive axle(s) will have a direct effect on the steering control of the vehicle.

Determine the front and rear axle weights by weighing the vehicle on scales designed for this purpose.

The maximum axle weight ratings are given on the Federal Motor Vehicle Safety Standard (FMVSS) label or Canadian Motor Vehicle Safety Standard (CMVSS) label attached to the left rear door post of the tractor. The desired load on the axle is no less than 80 percent of the maximum axle weight rating, but in no instances should the axle load exceed the maximum axle weight rating given on the FMVSS or CMVSS label.



**Adjust the fifth wheel slide correctly, and do not overload any tractor axle by improperly loading the trailer. Incorrect slide adjustment or improper axle loading could cause erratic steering and loss of vehicle control, possibly resulting in serious personal injury or death.**

## Pretrip Inspection and Daily Maintenance

Pretrip Inspection Checklist .....	9.1
Pretrip Inspection and Daily Maintenance Procedures .....	9.3

# Pretrip Inspection and Daily Maintenance

---

## Pretrip Inspection Checklist

The following pretrip inspection checklist helps ensure that the vehicle components are in good working condition before each trip.

Pretrip inspections cannot be performed in a short period. In checklist form, the sequence below may seem to be overly time-consuming. However, careful pretrip inspections save time by eliminating stops later to adjust items overlooked or forgotten.

Each checklist step corresponds with detailed instructions found under "Pretrip Inspection and Daily Maintenance Procedures." If any system or component does not pass this inspection, it must be corrected before operating the vehicle. See the *Business Class® Trucks Service Manual* for repair procedures, and the *Business Class® Trucks Maintenance Manual* for lubricant recommendations, specifications, and maintenance intervals and procedures.

**NOTE:** Apply the parking brakes and chock the tires.

1. Drain the air brake system air reservoirs if equipped.
2. Inspect the batteries and battery cables.
3. Check the fluid level in the windshield washer reservoir.
4. Check the front hub lubricant level (if equipped with oil-lubricated wheel bearings).
5. Tilt the hood. Examine the steering gear components.
6. Check the power steering hoses for chafing.
7. Check the coolant level in the surge tank sight glass and check the radiator and air-to-air after-cooler cooling fins for clogging or damage.  
  
Check the radiator for coolant leaks.
8. Check the condition of the coolant hoses and heater hoses.
9. Check the condition of the drive belts.
10. Inspect the engine for fuel, oil, and coolant leaks.
11. Inspect the engine and chassis wiring.
12. Inspect the air intake system for leaks or damage. Check the intake-air restriction indicator if it is mounted on the air intake system.
13. Check the fluid level in the hydraulic brake fluid reservoir if equipped.
14. Check the fluid level in the hydraulic clutch fluid reservoir if equipped.
15. Check the engine oil level.

# Pretrip Inspection and Daily Maintenance

---

16. Check the oil level in the automatic transmission if equipped.
17. Check the fuel water separator (if equipped) for contaminants.
18. Close the hood and engage the hood hold-down latches.  
  
Close the drain valves on the air brake system air tanks.
19. Inspect the fuel tank(s) and fuel line connections. If so equipped, be sure that the fuel tank shutoff valves are open.
20. Check the fuel level in the fuel tank(s) and be sure that the fuel cap vent area is clean. If so equipped, check the fuel/water separator for leaks. If needed, prime the fuel tank system.
21. If so equipped, check the transmission oil cooler for debris and for leaks.
22. If so equipped, inspect the fifth wheel and check it for adequate lubrication.
23. Inspect the front and rear suspension components, including the springs, shocks, and suspension brackets.
24. Clean the headlights, rearview and downview mirrors, and the outside of the windshield and all window glass. Check the condition of the windshield wiper arms and blades.
25. Clean the inside of the windshield, the gauges on the dash, and all window glass.
26. Check for excessive play at the steering wheel.
27. Adjust the driver's seat, then align the rearview and downview mirrors.
28. On mechanical clutch linkages (if equipped), check the clutch pedal free-travel.
29. Check the seat belts for secure mounting and for damage.
30. Check the cab interior for loose items and secure or remove them.
31. Check the air restriction indicator if it is dash mounted.
32. Turn on the ignition and start the engine. Be sure that the air- and oil-pressure warning systems, if equipped, are operating. Leave the engine running.
33. Make sure that the electric horn and air horn, windshield wipers and washer, heater and defroster, and mirror heat, if so equipped, are operating properly.
34. Check the operation of the backup alarm if so equipped.

# Pretrip Inspection and Daily Maintenance

---

35. Turn on the lights. Check the operation of all gauge lights and interior lights. Leave the lights on.
36. On tractor-trailer combinations, inspect the 7-way trailer cable receptacle(s) for good connections.
37. If not already done, hook the trailer(s) to the vehicle and inspect the trailer system.
38. Make sure that all of the lights are working, including the brake lights, fog lights (if so equipped), high- and low-beam headlights, turn signals, clearance lights, and four-way flashers. Check the condition of the reflectors. Turn the lights off.
39. Check the outer surfaces of the hood, cab, and trailers for visible surface breaks and damage. Make sure that the trailer doors are secure.
40. Inspect the air brake components (if equipped), including the brake chamber pushrods, air reservoirs, and air lines.
41. Check brake lining wear on vehicles with air brakes.
42. Make sure that the brakes are adjusted on all axles.
43. Check the tire inflation pressures and inspect each tire for bulges, cracks, cuts, and penetrations. Check tire wear.

44. Check for indications of loose wheel nuts or rim nuts and examine each rim and wheel component.
45. Check the air brake system for proper operation.
46. Test the service brakes before leaving the lot.
47. Test the parking brakes on a 20-percent grade.

## Pretrip Inspection and Daily Maintenance Procedures

Whenever equipment requires adjustment, replacement, repair, addition of lubricants, or a change of lubricants, see the *Business Class® Trucks Service Manual* for repair procedures and specifications, and the *Business Class® Trucks Maintenance Manual* for lubricant recommendations, specifications, and maintenance intervals and procedures.

1. *Drain the air brake system air reservoirs if equipped.*

Air reservoirs serve as storage tanks for compressed air. They collect water condensed from the air and small amounts of oil from the air compressor. Water and oil normally enter the reservoir in the form of vapor because of the heat generated during compression.



# Pretrip Inspection and Daily Maintenance

After the water and oil condense, they collect near the tank drain valves. Drain the resulting emulsion as follows:

## WARNING

**Failure to drain the air reservoirs as instructed could cause sludge formation in the air brake system. Sludge could adversely affect braking, causing loss of control, which could cause injury or damage.**

NOTE: If the air tanks are not equipped with automatic drain valves, they must be drained daily. If they are equipped with automatic drain valves, they must be drained in this same manner at least once a week.

- 1.1 Open the wet tank valve (the drain cock or pull-chain drain located on the forward end of the supply air reservoir, which is connected directly to the air compressor). Block the valve open.

## WARNING

**When draining the air reservoir, do not look into the air jets or direct them toward anyone. Dirt or sludge**

**particles may be in the airstream and could cause injury.**

- 1.2 Exhaust the remaining air and moisture from the system by opening the drain cocks on the bottoms of the remaining air reservoirs. Block the valves open.
- 1.3 Water and oil emulsion often form pockets which will not drain while compressed air is in the reservoirs. Because of these pockets, leave the valves blocked open during the first part of the pretrip inspection.

2. *Inspect the batteries (Fig. 9.1) and battery cables as follows:*

## WARNING

**Battery posts, terminals, and related accessories contain lead and lead compounds, chemicals known to the State of California to cause cancer and reproductive harm. To prevent possible personal injury, always wash your hands after handling battery parts and related accessories.**

- 2.1 Open the driver's door to access the batteries under the cab floor. Be sure that the battery hold-down is secure. If it is loose, tighten the hold-down bolts; if it is broken, replace it.

# Pretrip Inspection and Daily Maintenance

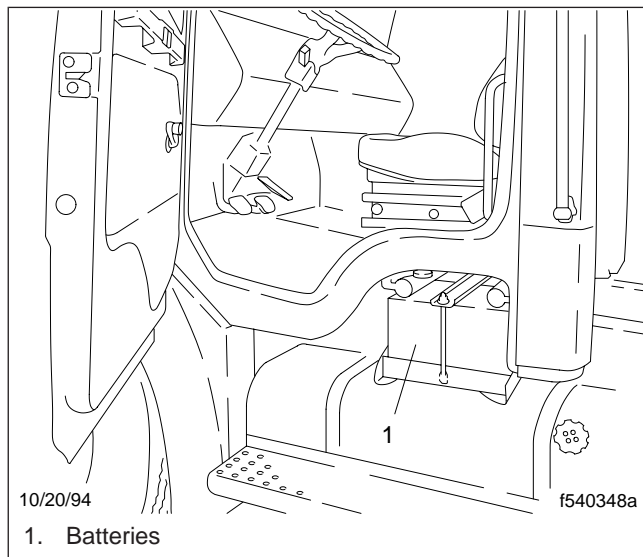

Fig. 9.1, Battery Location

## CAUTION

Take care to keep the vent plugs tight so that the neutralizing solution does not enter any of the battery cells.

- 2.2 Remove any corrosion from the hold-down and the top of the battery. Use diluted ammonia or a soda solution to neutralize the acid present, then rinse off the ammonia or soda solution with clean water.

If the battery posts or cable terminals are corroded, disconnect the terminals from the posts. Clean them with a soda solution and a wire brush. After cleaning, connect the terminals to the battery posts, then apply a thin coat of petroleum jelly to the posts and terminals to help retard corrosion.

3. Check the fluid level in the windshield washer reservoir.

Open the passenger's door to access the reservoir under the cab floor. Add washer fluid as needed.

## WARNING

Washer fluids may be flammable and poisonous. Do not expose washer fluid to an open flame or any burning material, such as a cigarette. Always comply with the washer fluid manufacturer's recommended safety precautions.

4. Check the front hub lubricant level (if equipped with oil-lubricated wheel bearings).

# Pretrip Inspection and Daily Maintenance

Observe the level of the wheel bearing lubricant in the hub cap at each end of the front axle and if needed, fill the hubs to the level indicated on the hub cap. See **Group 33** of the *Business Class® Trucks Maintenance Manual* for recommended lubricants.

**IMPORTANT:** Before removing the fill plug, always clean the hub cap and plug.

5. Tilt the hood. Examine the steering gear components.

Examine the steering gear mounting bolts (Fig. 9.2), pitman arm nut, and the drag link nuts for tightness. Be sure that the steering driveline and the U-joints are in roadworthy condition, without cracks, breaks, looseness, or other damage. Tighten loose nuts, and replace damaged parts as needed. See **Group 46** of the *Business Class® Trucks Service Manual*.

**NOTE:** On right-hand-drive vehicles, a linkage system runs from the steering driveline to the steering gear on the left-hand frame rail.

6. Check the power steering hoses for chafing.

Check for leakage around the fittings. Replace any damaged hoses and tighten all fittings to stop leakage.

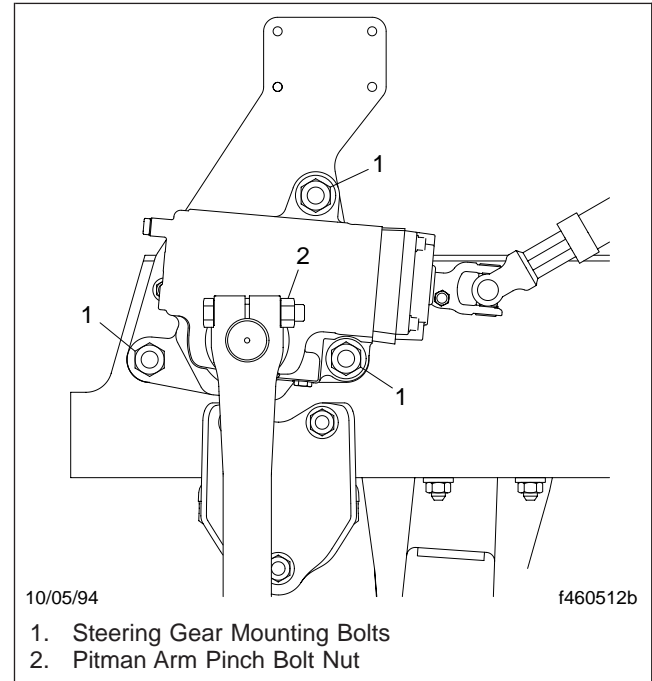

**Fig. 9.2, Steering Gear (TAS series shown)**

# Pretrip Inspection and Daily Maintenance

## CAUTION

Low coolant could result in engine overheating, which could cause engine damage.

7. Check the coolant level in the surge tank sight glass. See **Fig. 9.3**. Check the condition of the radiator fins, the A/C condenser, and the charge air cooler (as equipped).

If the coolant is low, check the amount of antifreeze protection. If the protection is adequate, add a 50/50 mixture of water and antifreeze. If additional protection is needed, add antifreeze only. Add until the level is at the bottom of the surge tank fill neck.

Good airflow through the radiator core and air-to-air aftercooler core is essential for proper engine cooling. The cores allow air passage, but form a particle barrier which tends to collect insects and airborne debris.

Inspect for clogged fins. Use compressed air or water directed from the fan side of the core to back-flush any material restricting airflow.

On vehicles equipped with air conditioning and/or a charge air cooler, also inspect and clean these components. If clogged, the airflow through the radiator could be restricted.

Straighten bent or damaged fins to permit airflow across all areas of the cores.

Repair or replace the radiator if it is leaking. See **Group 20** of the *Business Class® Trucks Service Manual* for instructions.

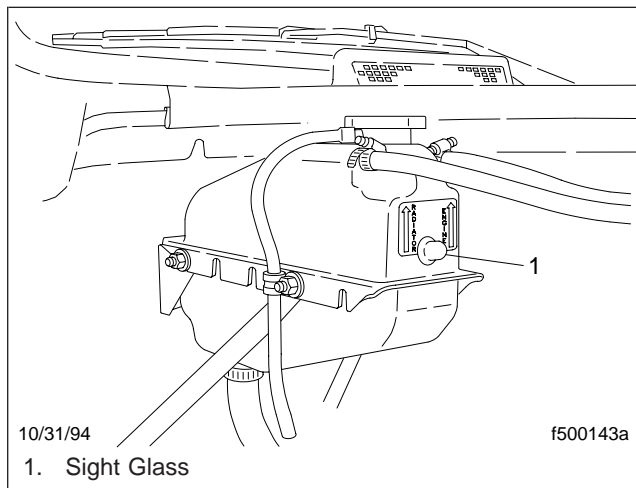

**Fig. 9.3, Surge Tank with Sight Glass**

**NOTE:** When traveling through areas of high insect concentrations, it may be necessary to clean the exterior of the radiator or aftercooler core as often as every 200 miles (320 km).

# Pretrip Inspection and Daily Maintenance

8. Check the condition of the coolant hoses and heater hoses.

Make sure that the radiator inlet and outlet coolant hoses and heater hoses are pliable and are not cracking or ballooning. Replace hoses that show signs of cracking, weakening, or ballooning. Replace all hoses, including heater hoses, at the same time. Service-type knitted or braided yarn-reinforced neoprene hose is acceptable.

Silicone hoses, having an extended service life, can be substituted for the reinforced neoprene type. See the *Service Parts Catalog* or contact your Freightliner Dealer.

Tighten hose clamps as necessary, but do not over-tighten as hose life can be adversely affected.

Be sure that the hose support brackets are securely fastened. Make sure that the hoses are not located near sources of wear, abrasion, or high heat.

9. Check the condition of the drive belts.

Check the fan belt(s), alternator belt, and refrigerant compressor belt for signs of glazing, wear (frayed edges), damage (breaks or cracks), or oil contamination. If a belt is glazed, worn, damaged, or oil soaked, replace the belt following the instructions in **Group 01** of the *Business Class® Trucks Service Manual*.

Check all of the belts for proper tension. Use your index finger to apply approximately 25 pounds (11 kg) of force at the center of the belt free-span. See **Fig. 9.4**. Deflection should be one belt thickness per 1 foot (300 mm) of belt free-span. If the tension is more than or less than this value, measure it with a belt-tension gauge and adjust it to the proper tension. See **Group 01** of the *Business Class® Trucks Service Manual* for instructions.

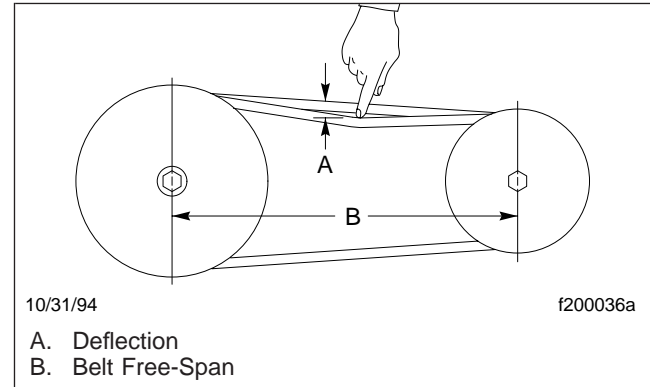

**Fig. 9.4, Checking Belt Tension**

**NOTE:** On Cummins engines, a belt tensioner automatically adjusts the fan and alternator belt to

# Pretrip Inspection and Daily Maintenance

---

the correct tension. If the belt slips, repair or replace the tensioner. For instructions, see the *Cummins Shop Manual B Series Engines*.

10. *Inspect the engine for fuel, oil, and coolant leaks.*

Correct any leaks found.

11. *Inspect the engine and chassis wiring.*

Inspect the engine and chassis for loose wiring, chafed insulation, and damaged or loose hold-down clamps. Tighten loose wires or hold-down clamps; replace damaged wiring or clamps.

12. *Check the air intake system for leaks or damage.*

Check the intake-air restriction indicator to determine if the air cleaner filter element needs to be changed. Replace the filter element if the yellow signal stays locked at 25 inH<sub>2</sub>O for Cummins engines or 20 inH<sub>2</sub>O for Mercedes-Benz engines. See **Group 09** of the *Business Class® Trucks Service Manual* for filter element replacement instructions.

Check the engine air intake piping from the air cleaner to the engine intake. Inspect the piping for loose connections, cracks, torn or collapsed hoses, punctures, and other damage. Tighten loose connections and replace damaged components. Make sure that the piping system is airtight so that all of the intake air passes through the air cleaner.



## CAUTION

**Failure to maintain a sealed air intake system could allow the entry of contaminants into the engine. This could adversely affect engine performance and result in engine damage.**

NOTE: After replacing the filter element, reset the restriction indicator by pressing the reset button.

13. *Check the fluid level in the hydraulic brake fluid reservoir (Fig. 9.5) if equipped.*

If needed, fill the reservoir to the flange that surrounds the reservoir. Use only heavy-duty brake fluid, DOT 3.

14. *Check the fluid level in the clutch fluid reservoir (Fig. 9.6).*

The reservoir is full when the fluid level is at the MAX mark. The fluid level must always be above the MIN mark. Use only heavy-duty brake fluid, DOT 3, in the hydraulic-clutch system.

15. *Check the engine oil level (Fig. 9.7).*

The oil level should show between the upper and lower marks on the dipstick. Add enough oil to bring the level up to the operating range. See the engine

# Pretrip Inspection and Daily Maintenance

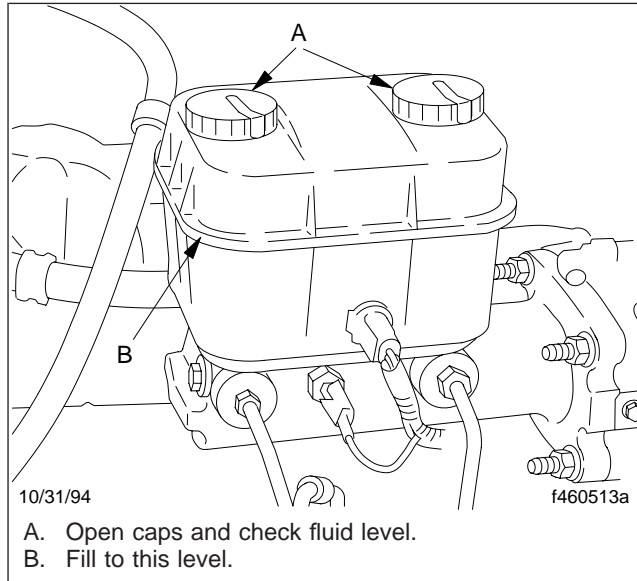

**Fig. 9.5, Hydraulic Brake Fluid Reservoir**

manufacturer's operation and maintenance manual for recommended lubricants and capacities.

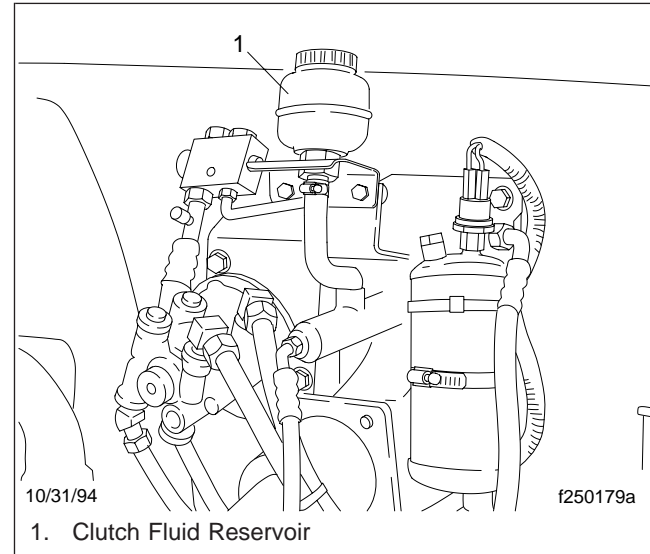
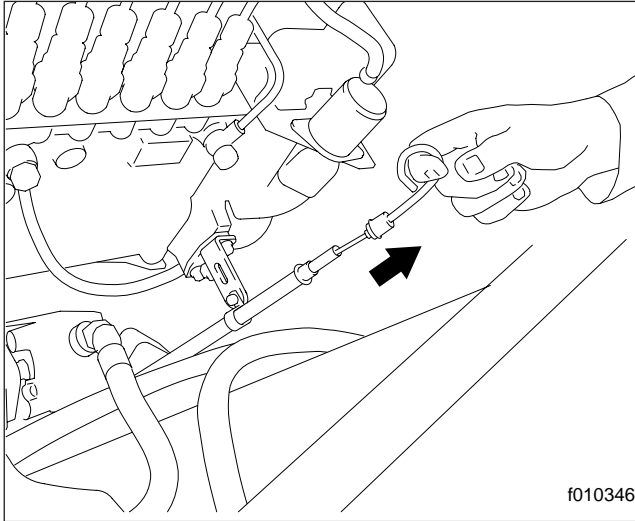

**Fig. 9.6, Check Clutch Fluid Level**

**CAUTION**

Operating the engine with the oil level below the low mark or above the high mark could result in engine damage.

# Pretrip Inspection and Daily Maintenance



**Fig. 9.7, Engine Oil Level Checking**

16. Check the oil level in the automatic transmission if equipped.

NOTE: The fluid must be warm to ensure an accurate check. The fluid level rises as temperature increases.

With the vehicle on a level surface, check the oil level (the dipstick is next to the windshield washer

reservoir) in the transmission using one of the following procedures:

## Hot Check

- Operate the transmission in a Drive (D) range until normal operating temperature, 160 to 200°F (71 to 93°C), is reached.
- Park the vehicle. Shift to Neutral (N) and apply the parking brake. Let the engine run at idle.
- Wipe the dipstick clean and check the fluid level. A safe operating level is any level within the HOT RUN (upper) band on the dipstick.
- If the fluid is not within this range, add or drain fluid as needed to bring the level to the top of the HOT RUN band. See the *Business Class® Trucks Maintenance Manual* for fluid types and capacities.

## Cold Check

- A cold check may be made when the sump temperature is 60 to 104°F (15 to 40°C).
- Run the engine for at least one minute to clear the fluid system of air.
- With the engine running, wipe the dipstick clean and check the fluid level. Any level within the



# Pretrip Inspection and Daily Maintenance

COLD RUN (lower) band is satisfactory for operating the vehicle. If the level is not within the COLD RUN band, add or drain fluid until it reaches the middle of the COLD RUN band.

- Perform a hot check at the first opportunity after normal operating temperature, 160 to 200°F (71 to 93°C), is reached.

17. *Check the fuel water separator (if equipped) for contaminants.*

With the engine shut down, partially open the drain valve under the collection bowl and drain water and contaminants as needed.

18. *Lower the hood and engage the hood hold-down latches.*

19. *Inspect the fuel tank(s) and fuel line connection. If equipped, be sure that the fuel tank shutoff valves are open.*

Replace leaking fuel tanks. Repair or replace any lines or connections that are leaking. For procedures, see **Group 47** of the *Business Class® Trucks Service Manual*.

If equipped with fuel tank shutoff valves, be sure that the valves are fully open.

## **WARNING**

**Never operate the engine with the fuel tank shutoff valves partly closed. This could damage the fuel pump, causing sudden loss of engine power, possibly resulting in serious personal injury due to reduced vehicle control.**

20. *Check the fuel level in the tank(s) and be sure that the fuel cap vent area is clean. Check the fuel/water separator (if equipped) and if needed, prime the fuel tank system.*

## **WARNING**

**Never fill fuel tanks to more than 95 percent of their liquid capacity. This could make them more likely to rupture from impact, possibly causing fire and resulting in serious personal injury or death by burning.**

**IMPORTANT:** Use only low-sulfur diesel fuels. Low-sulfur diesel fuels have a maximum 0.05 percent sulfur content compared to a 0.26 to 0.30 percent sulfur content for other fuels. Failure to use low-sulfur diesel fuels may void the warranty on emission components.

# Pretrip Inspection and Daily Maintenance

---

- 20.1 To keep condensation to a minimum, fill the fuel tanks at the end of each day, but not to more than 95 percent of liquid capacity. Select the proper grade of fuel as specified by the engine manufacturer.

## WARNING

**Do not mix gasoline or alcohol with diesel fuel. This mixture could cause an explosion. When filling fuel tanks, do not smoke or use an open flame near the fuel tanks; combustion of diesel fuel oil or fuel vapors could result.**

- 20.2 Always strain or filter fuel before putting it into the tanks. This will lengthen the life of the engine fuel filter and reduce the chances of dirt entering the engine.
- 20.3 Before installing the fuel cap, check the vent line for debris. Clean the area around the fuel tank cap with a rag, or if necessary, clean the cap with solvent.

---

## CAUTION

**Don't crank the engine for more than 30 seconds at a time during any of the following procedures. Wait two minutes after each try to allow the starter to cool. Failure to do so could cause starter damage.**

**IMPORTANT:** Before doing any of the following procedures, make sure that there is an adequate amount of fuel in the tank(s). Do not fill the tank(s) to more than 95 percent of liquid capacity.

- 20.4 On vehicles equipped with a single tank, prime the fuel system if needed. On vehicles with dual tanks, go to the next substep.

*If the engine is equipped with a priming pump, do the following:*

Unlock and operate the engine's priming pump plunger until resistance is felt.

Push the plunger in and tighten it by hand.

Start the engine. If it doesn't start, more priming is needed. Once the engine has started it may run rough. If this occurs, run the engine at low idle until it runs smoothly.

*If the engine is not equipped with a priming pump, do the following:*

Remove the fuel tank cap.

Loosen the fuel supply line at the fuel transfer pump.

Partially cover the fuel tank opening with your hand. Using an air hose, apply no more

# Pretrip Inspection and Daily Maintenance

than 5 psi (35 kPa) air pressure to the fuel tank and look for a constant fuel flow at the loosened fuel supply line.

Remove the air hose and tighten the fuel supply line.

Start the engine. Once the engine has started, it may run rough. If this occurs, run the engine at low idle until it runs smoothly.

**IMPORTANT:** To prevent fuel loss or entry of air into a fuel line, make sure that all fuel line connections are tight.

20.5 On vehicles equipped with dual tanks and single suction and return lines (with cross-over line), prime the fuel system if needed.

Use the same procedure provided in the previous substep for vehicles equipped with a single tank. Use the procedure on the tank equipped with the supply line.

21. *If equipped, check the transmission oil cooler for debris and for leaks.*

Remove debris and repair leaks as needed.

22. *If so equipped, inspect the fifth wheel and check it for adequate lubrication.*

## **WARNING**

**Physically check to be sure that the trailer is securely connected to the tractor. Failure to achieve complete fifth wheel lockup may allow disengagement of the tractor from the trailer, possibly resulting in serious personal injury or death.**

22.1 If the vehicle is a truck-trailer combination, be sure that the trailer hitch is locked and that the safety cable or chains are connected. Be sure that air hoses and the light cable are connected.

## **WARNING**

**Check the lock mechanisms described above. Otherwise the trailer could disengage from the tractor, possibly resulting in serious personal injury or death.**

22.2 If the vehicle is a tractor-trailer combination, check that the fifth wheel lock mechanism is locked to the trailer kingpin. See **Chapter 8** for instructions.

# Pretrip Inspection and Daily Maintenance

---

## **WARNING**

Repair or replace damaged fifth wheel components. Otherwise the trailer could disengage from the tractor, possibly resulting in serious personal injury or death.

NOTE: For adjustment and replacement instructions, see **Group 31** of the *Business Class® Trucks Service Manual*.

22.3 With the trailer unhooked from the tractor, inspect the fifth wheel (daily) for the following conditions:

- Loose nuts or broken bolts on the fifth wheel assembly, slider mechanism, and mounting brackets. Replace broken bolts and tighten loose nuts.
- Cracks or wear on the fifth wheel assembly and mounting brackets. Replace each damaged or worn component.
- Incorrect jaw locking action and cracks or wear on the jaw locking mechanism. Replace the mechanism if cracked or worn; repair it if the jaw locking action is incorrect.

- Gouges or wear on the fifth wheel plate. Replace the plate if damaged or worn.
- Fatigue or cracking of welds, which must be repaired according to the manufacturer's specifications.

## **WARNING**

**Keep the fifth wheel plate lubricated to prevent binding between the tractor and trailer. A binding fifth wheel could cause erratic steering and loss of vehicle control, possibly resulting in serious personal injury or death.**

22.4 Lubricate the fifth wheel top plate and other grease points at least once a week, and more often in severe service.

Before connecting the fifth wheel to the trailer kingpin, always be sure that the fifth wheel plate is completely lubricated with chassis grease.

22.5 Clean all foreign material from the fifth wheel top plate. Lubricate the top plate surface, pickup ramps, and mounting bracket pivot pins using a waterproof or multipurpose chassis lubricant. Lubricate the jaw mechanism on all units except the Fontaine 5000

# Pretrip Inspection and Daily Maintenance

series fifth wheel. (Fontaine recommends that jaws and wedges remain dry to avoid accumulation of abrasive matter.)

23. *Inspect the front and rear suspension components, including the springs, shocks, and suspension brackets.*

Check for broken spring leaves, loose U-bolts, cracks in the suspension brackets, and loose fasteners in the spring hangers and shackles. Inspect the shock absorbers for loose fasteners and leaks.

Tighten all loose fasteners and replace any component that is worn, cracked, or otherwise damaged.

## WARNING

**Do not replace individual leaves of a damaged front or rear suspension leaf spring assembly; replace the complete spring assembly. Visible damage (cracks or breaks) to one leaf causes hidden damage to other leaves. Replacement of only the visibly damaged part(s) is no assurance that the spring is safe. On front spring assemblies, if cracks or breaks exist in either of the two top leaves, a loss of vehicle control could occur. Failure to replace a damaged spring assembly could cause an accident resulting in serious personal injury or property damage.**

## WARNING

**When cleaning windshields and windows, always stand on the ground or on a secure ladder or platform. Use a long-handled window cleaner. Do not use the cab steps, tires, fenders, fuel tanks, engine, or under-hood components to access the windshield or windows. To do so could cause a fall and result in an injury.**

24. *Clean the headlights, rearview and downview mirrors, and the outside of the windshield and all window glass. Check the condition of the windshield wiper arms and blades.*

Clean the windshield and side windows with a long-handled or telescoping window cleaning device and standard cleaning solutions. Stand only on the ground or on a stepladder or elevated walkway. The cab entry/exit steps and handholds are not designed for this purpose. The tires, fenders, fuel tanks, engine, and other under-hood components do not have adequate gripping surfaces and handholds.

Access rear windows on tractors from the deck plate. Place the cleaning materials on the deck plate first so that your hands are free to climb up

# Pretrip Inspection and Daily Maintenance

and down from the vehicle. If no deck plate is available, clean the rear windows using the same procedures as in the previous paragraph for cleaning the windshield and the side windows. Do not use the fuel tanks as a work platform.

Be sure that the windshield wiper blades are tensioned against the windshield. Inspect the wiper blades for damage and deteriorated rubber. Replace the wiper arms if the wiper blades are not tensioned against the windshield. Replace damaged or deteriorated wiper blades.

## **WARNING**

**Replace wiper arms and blades whenever necessary to maintain good visibility. Poor visibility could interfere with the driver's ability to control the vehicle, possibly resulting in serious personal injury or death.**

25. *Clean the inside of the windshield, the gauges on the dash, and all window glass.*
26. *Check the steering wheel for excessive play.*

With the front tires pointed straight ahead, turn the steering wheel until motion is observed at the front wheels. Align a reference mark on a ruler, then slowly turn the steering wheel in the opposite direction until motion is again detected at the wheels.

Measure the lash (free play) at the rim of the steering wheel. See **Fig. 9.8**.

Excessive lash exists if steering wheel movement exceeds 4-3/4 inches (121 mm) with an 18-inch (470-mm) steering wheel. If there is excessive lash, check the steering system for wear or incorrect adjustment of the linkage and steering gear before operating the vehicle.

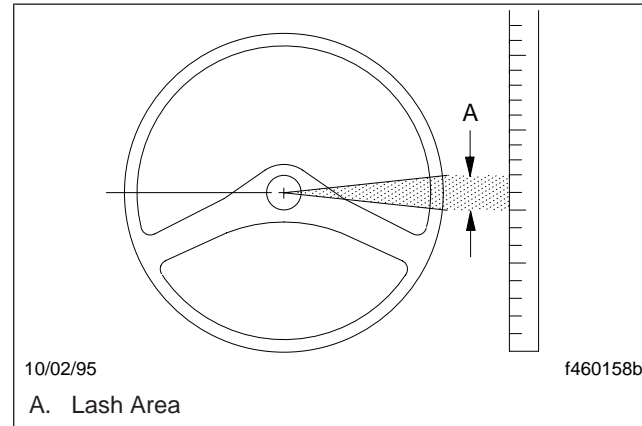

**Fig. 9.8, Measuring Lash at the Steering Wheel**

27. *Adjust the driver's seat, then align the rearview and downview mirrors.*

# Pretrip Inspection and Daily Maintenance

## 28. Check the clutch pedal free-travel.

The main indicator for assessing clutch wear is clutch pedal free-travel. Clutch pedal free-travel is a decreased resistance felt at the top of the clutch pedal stroke. With the clutch pedal in this range, the clutch is fully engaged and the only resistance to clutch pedal movement is return spring tension. Clutch pedal free-travel should be approximately 1-1/2 to 2 inches (38 to 51 mm). See [Fig. 9.9](#). If the clutch pedal free-travel is less than 3/4 inch (19 mm), the clutch must be adjusted internally. For instructions, see **Group 25** of the *Business Class® Trucks Service Manual*.

### CAUTION

Excessive clutch pedal free-travel may prevent complete clutch disengagement. Insufficient clutch pedal free-travel causes slippage and short clutch life. Never wait for the clutch to slip before making a clutch adjustment.

## 29. Inspect the seat belts and tether belts (if so equipped). See [Fig. 9.10](#).

### WARNING

Inspect and maintain seat belts as instructed below. Worn or damaged seat belts could fail during a sud-

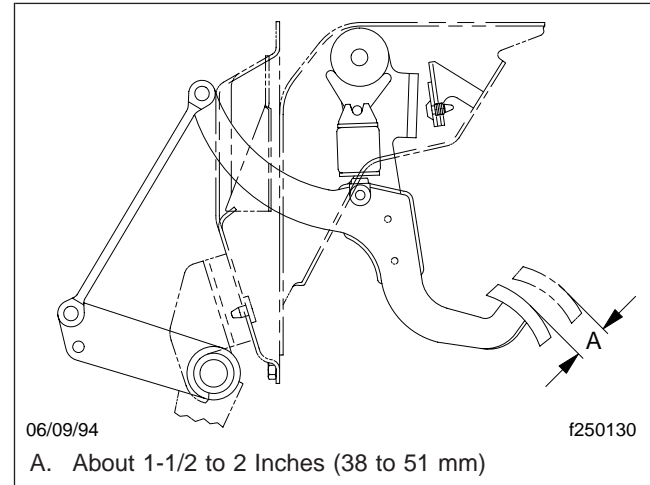

**Fig. 9.9, Check Clutch Free Pedal**

den stop or crash, possibly resulting in serious injury or death.

**NOTE:** When any part of a seat belt system needs replacement, the entire seat belt must be replaced, both retractor and buckle side.

- 29.1 Check the web for fraying, cuts, or extreme wear, especially near the buckle latch plate and the D-loop guide area.

# Pretrip Inspection and Daily Maintenance

- 29.2 Check the web for extreme dirt or dust and for severe fading from exposure to sunlight.
  - 29.3 Check the buckle and latch operation and for wear or damage.
  - 29.4 Check the Komfort Latch function and for cracks or other damage.
  - 29.5 Check the web retractor function and for damage.
  - 29.6 Check the tightness of the mounting bolts and tighten any that are loose.
30. *Check the cab interior for loose items and secure or remove them.*
31. *Check the air restriction indicator if it is dash mounted.*
- Use the same procedure provided for systems with the indicator mounted on the air intake system.
32. *Start the engine and make sure that the oil-pressure and air-pressure warning systems are working.*

When the engine is started, oil-pressure and air-pressure warnings will come on until the oil pressure rises above a preset minimum and the air pressure in both the primary and secondary air reservoir systems goes above 64 to 76 psi (441 to 524 kPa). If the air pressure in both systems is above

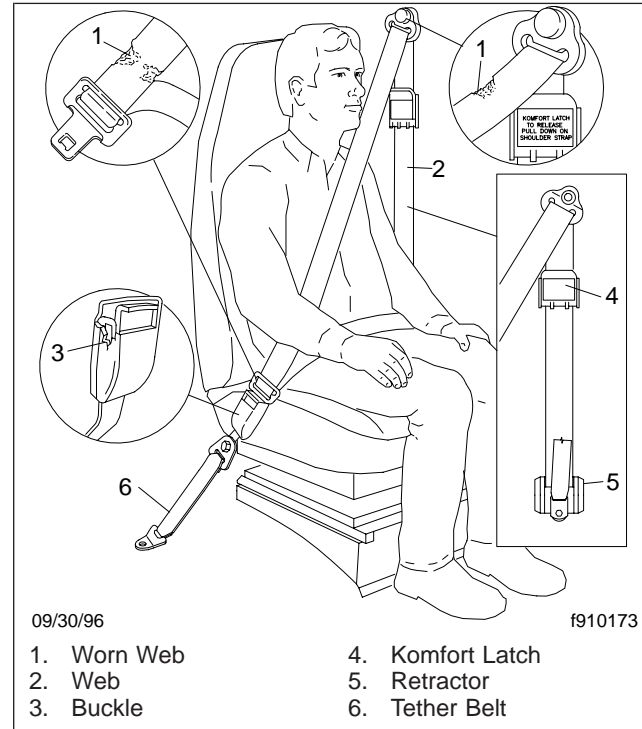

**Fig. 9.10, Seat Belt Inspecting**

64 to 76 psi (441 to 524 kPa) when the engine is started, test the low pressure warning system by



# Pretrip Inspection and Daily Maintenance

lowering the pressure to below this range or until the warning system comes on.

If the warning systems do not come on when the ignition is turned on, repair the systems.



## CAUTION

**Failure to repair the engine shutdown/warning system could result in a sudden engine shutdown, without warning, during vehicle operation.**

33. *Make sure that both the electric horn and the air horn work. Then check the wiper and washer control. During cold weather, check the operation of the heater and defroster controls and, if equipped with optional mirror heat, turn on the mirror heat switch and make sure that the system is working.*

These devices must be in good working order for safe vehicle operation. If they are not working, repair them before trip departure.

34. *Check the operation of the backup alarm if so equipped.*
35. *Check the operation of all gauge lights and interior lights.*

Turn on the headlights, dash lights, and four-way flashers, and leave them on. Check the operation of the dome light.

If any of the gauge bulbs, the switch panel label bulb, the dome light bulb, or the right- and left-turn indicator bulbs are not working, replace them.

36. On tractor-trailer combinations, inspect the 7-way trailer cable receptacle(s) for good connections.

Clean and grease the 7-way socket and plug regularly, especially in regions where magnesium chloride or calcium chloride are used as road de-icers. These chemicals are highly corrosive to brass and copper, the base materials for the contact pins used in the 7-way receptacles. Clean the socket and plug with a plug brush and apply a moderate amount of dielectric grease to both the socket and plug pins. See **Group 15** of the *Business Class® Trucks Maintenance Manual* for an approved dielectric grease.

37. *Hook the trailer(s) to the vehicle and inspect the trailer system.*

Whether or not the trailer was already hooked to the vehicle, check the following:



## WARNING

**Check the lock mechanisms described above. Otherwise the trailer could disengage from the tractor, possibly resulting in serious personal injury or death.**

# Pretrip Inspection and Daily Maintenance

---

37.1 Make sure that all fifth wheel connections are engaged and locked. Check that all connections to the dolly or trailer hitch and safety chains are secure.

37.2 Make sure that the gladhands in front of each trailer are engaged and that all air hoses are properly suspended.

37.3 Make sure that the air shutoff valves are turned on and that air is available to the lines on the trailer(s).

Make sure that the air shutoff valve at the back of the last trailer is turned off.

37.4 Make sure that all light cables are connected and correctly suspended.

Check that all trailer lights are working.

37.5 On semi-trailers, make sure that the landing gear supports are raised and that the handles are secure.

See the trailer manufacturer's detailed trailer inspection procedures for additional information.

38. *Make sure that all of the lights are working.*

Be sure that the brake lights, taillights, side marker lights, fog lights (if so equipped), headlights, signal

lights, and clearance and identification lights are working and are clean. See **Fig. 9.11**. Test the high beams and the low beams of the headlights.

Replace light bulbs or sealed beam units that are not working.

Be sure that all reflectors and lenses on the tractor and trailer(s) are in good condition and are clean. Replace any broken reflectors or lenses. Turn the lights off.

39. *Check the outer surfaces of the hood, cab, and trailers for visible surface breaks and damage. Make sure that the trailer doors are secure.*

40. *Inspect the air brake components (if equipped), including the brake chamber pushrods, air reservoirs, and air lines.*

Look for worn pins on brake chamber pushrods, and missing or damaged cotter pins on the brake chamber pushrod pins. Replace worn pins and install new cotter pins if necessary.

Check for rusted connections, missing snap rings, and damaged camshaft grease seals. Repair or replace damaged or missing parts. Check the air reservoir band fasteners. Make sure that the outside surfaces of the reservoirs are painted to prevent corrosion damage. Inspect the reservoir surfaces for damage, such as cracks and dents.

# Pretrip Inspection and Daily Maintenance

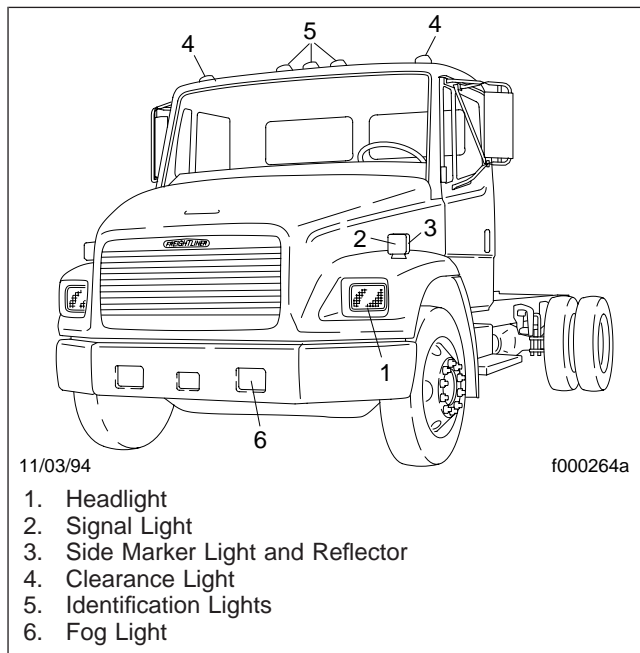

**Fig. 9.11, Exterior Light Locations**

Replace corroded or damaged reservoirs with new ones. Do not repair damaged reservoirs. Old or used reservoirs are not acceptable as replacements. If a reservoir requires replacement, see

**Group 42** of the *Business Class® Trucks Service Manual* for instructions.

Inspect the front air brake lines for leaks at the fitting where the lines enter the air chamber.

With an assistant, turn the wheels to full lock in one direction and hold down the service brake pedal. Carefully inspect the front brake air lines where the lines enter the air chambers. Turn the wheels to full lock in the other direction, hold down the service pedal, and repeat the inspection.

If there is a leak, replace the hose. See **Group 42** of the *Business Class® Trucks Service Manual* for the hose replacement procedure.

Inspect the air lines as follows:

- 40.1 Check the clearance between the hoses, exhaust manifold, and turbocharger or other hot spots. Excessive heat will cause the material in the hoses to deteriorate rapidly or become brittle. Provide at least six inches (150 mm) of clearance. More clearance is recommended if the hose is located above the heat source.
- 40.2 Check for kinks, dents, or swelling of the hoses. If a hose is damaged, replace it with the same size and type.

# Pretrip Inspection and Daily Maintenance

- 40.3 Do not route the hose on top of anything likely to be stepped on or walked on.
- 40.4 Check for damage to hoses located near moving parts, such as drivelines, trailer bodies, kingpins, suspensions, and axles. If the moving parts are catching or pinching the lines, correct as needed.
- 40.5 Check for hose damage caused by abrasion. If a hose is abraded, replace it. Check for the cause of abrasion, such as loose or damaged hose clamps. Repair or replace the clamps as needed.
- 40.6 Observe the hose cover condition, especially hoses exposed to water splash and ice. If any hose is dried out or ragged (the wire or liner is showing through the cover), replace the hose.
- 40.7 Inspect air tubing, especially tubing made of nylon. In cold weather, nylon tubing is sensitive to damage, such as nicks or cuts. Replace nicked or cut tubing, even if it is not leaking.
- 40.8 Check the bend radii of all hoses. See [Fig. 9.12](#). The minimum bend radius of a hose is that bend which the hose will withstand without experiencing damaging stresses or kinking. For minimum bend ra-

dius values, see **Group 42** of the *Business Class® Trucks Service Manual*.

When a rubber hose does not meet minimum bend radius requirements, the outside may appear smooth even if the inner tube is kinked. Reroute the hose or replace it with one of adequate length if the bend radius is not within minimum specifications.

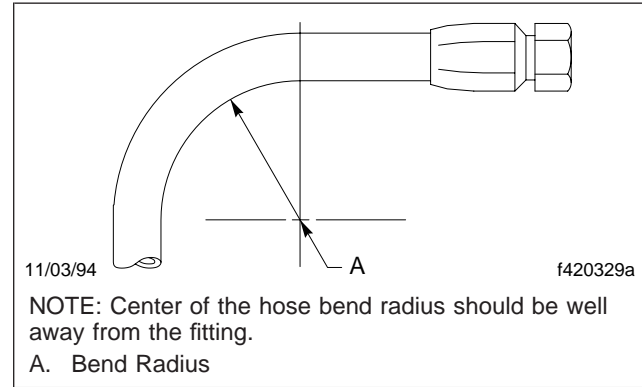

**Fig. 9.12, Bend Radius**

- 40.9 Check straight hose installations (those hoses that do not bend along their routings). Pressure changes can cause a hose to lengthen up to two percent or shorten up to

# Pretrip Inspection and Daily Maintenance

four percent. A 100-inch (2540-mm) length of hose, for example, can contract to 96 inches (2440 mm). If the hose has no slack when it is exhausted of air, replace it with one of adequate length to avoid a possible blow-off from the fitting during vehicle operation.

- 40.10 Check for kinked or twisted hoses. A seven-percent twist in the hose can reduce its life by up to 90 percent. Also, a twisted hose under pressure tends to untwist. This could cause it to loosen the fitting. Reconnect hoses that are twisted.

41. *Check brake lining wear on vehicles with air brakes.*



## WARNING

**Breathing brake lining dust (asbestos or non-asbestos) could cause lung cancer or lung disease. Unless exposure can be reduced below legal limits, wear an air purifying respirator approved by MSHA or NIOSH at all times when servicing the brakes, starting with removal of the wheels and continuing through assembly.**

**To reduce asbestos exposure below legal limits, apply one of the following methods: (1) An enclosed-cylinder vacuum system equipped with a High Efficiency Particulate Air (HEPA) filter; (2) A solvent**

**spray system that keeps the asbestos-contaminated parts wet until they can be placed in a sealed and labelled plastic bag.**

**IMPORTANT:** It is necessary to check brake lining wear on all vehicles, including those with automatic slack adjusters.

Before checking lining wear when the wheel and hub assembly are removed, review the brake lining exposure warnings above.

To minimize the possibility of creating airborne brake lining dust, clean the dust from the brake drum, brake backing plate, and brake assembly using an industrial-type vacuum cleaner equipped with a high-efficiency filter system. Then, using a rag soaked in water and wrung until nearly dry, remove any remaining dust. Do not use compressed air or dry brushing to clean the brake assembly.

- 41.1 Apply the parking brakes. Chock the tires to prevent vehicle movement.
- 41.2 If the axle assembly is equipped with a dust shield or backing plate, remove the access plug from the dust shield or backing plate.

# Pretrip Inspection and Daily Maintenance

---

NOTE: If unable to accurately measure the brake lining, remove the wheel and hub assembly for a thorough inspection.

41.3 Measure the brake lining thickness. If *any* of the brake linings are worn to less than 1/4 inch (6.5 mm) at the thinnest point, replace the linings on *all* brake assemblies on that axle.

NOTE: To replace the brake linings, see the applicable brake section in **Group 42** of the *Business Class® Trucks Service Manual*.

41.4 If removed, install the access plug. Remove the chocks from the tires.

42. *Make sure that the brakes are adjusted on all axles.*

Adjust the brakes if necessary. See **Group 42** of the *Business Class® Trucks Service Manual* for checking and adjusting procedures.

IMPORTANT: Brake checking and adjusting is necessary for all vehicles, including trucks equipped with automatic slack adjusters.

43. *Check the tire inflation pressures and inspect each tire for bulges, cracks, cuts, and penetrations. Check tire wear.*

IMPORTANT: The load and cold inflation pressure must not exceed the rim or wheel manufacturer's recommendations, even though the tire may be approved for a higher load or inflation. Some rims and wheels are stamped with a maximum load and maximum cold inflation rating. See **Group 40** of the *Business Class® Trucks Service Manual* for the correct tire inflation pressure for the vehicle load or consult the rim or wheel manufacturer if they are not stamped. If the load exceeds the maximum rim or wheel capacity, the load must be adjusted or reduced.

43.1 Check the inflation pressures of the tires before each trip using an accurate tire pressure gauge (**Fig. 9.13**). Tires should be checked when cool. See **Table 9.1** or **Table 9.2** for the correct tire inflation pressure for the vehicle load. When traveling at unusual speeds, use **Table 9.3** to adjust tire pressure. Be sure that valve stem caps are on every tire and that they are screwed on finger-tight. Inflate the tires to the applicable pressures if needed.

Overinflation gives the treaded surface of the tire a convex shape (**Fig. 9.14**). This causes extreme tire wear in the middle part

# Pretrip Inspection and Daily Maintenance

of the tire since this section is primarily in contact with the road.

Underinflation gives the tread surface a concave shape (Fig. 9.14). This causes excessive tire wear on the outer edges of the tire since the outer edges are primarily in contact with the road.

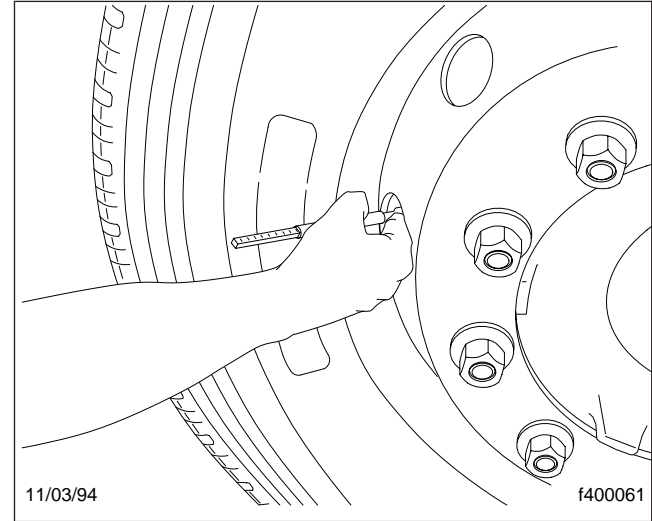

**Fig. 9.13, Check Tire Pressure**

# Pretrip Inspection and Daily Maintenance

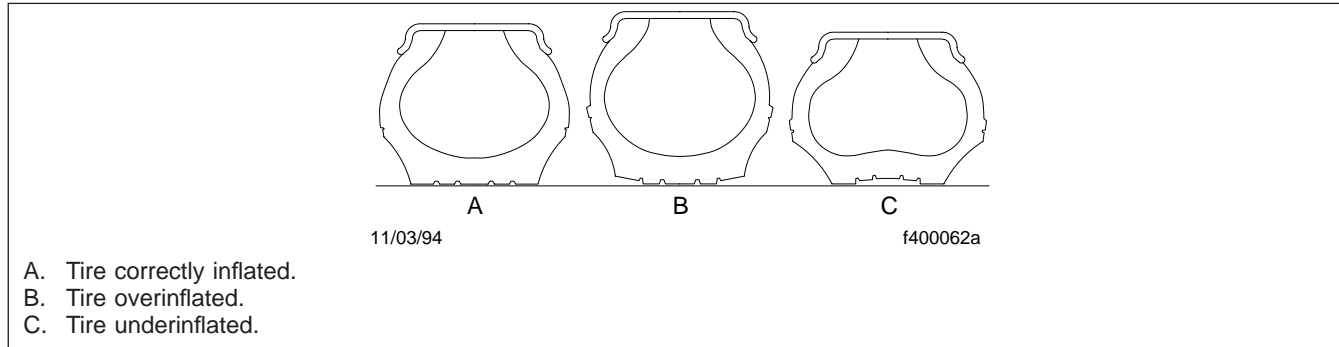

Fig. 9.14, Tire Inflation

Tire Load Limits, Bias Ply Tubeless Tires, at Various Cold Inflation Pressures (maximum 60 mph [97 km/h])																
Size	Load Range Ply Rating	Axle	Pressure in psi (kPa)													
			45 (311)	50 (345)	55 (380)	60 (414)	65 (448)	70 (483)	75 (517)	80 (552)	85 (586)	90 (621)	95 (655)	100 (689)	105 (724)	110 (758)
9-22.5	E-10	Front Rear	— —	— —	3010 2960	3190 3120	3370 3270	3560 3410	3730 3550	— —	— —	— —	— —	— —	— —	— —
9-22.5	F-12	Front Rear	— —	— —	3010 2960	3190 3120	3370 3270	3560 3410	3730 3550	3890 3690	4050 3820	4210 3950	— —	— —	— —	— —
10-22.5	E-10	Front Rear	— 3120	— 3310	3560 3510	3770 3690	4000 3870	4210 4040	4410 —	4610 —	— —	— —	— —	— —	— —	— —
10-22.5	F-12	Front Rear	— 3120	— 3310	3560 3510	3770 3690	4000 3870	4210 4040	4410 4200	4610 4360	4790 4520	4970 —	4970 —	5150 —	— —	— —



# Pretrip Inspection and Daily Maintenance

Tire Load Limits, Bias Ply Tubeless Tires, at Various Cold Inflation Pressures (maximum 60 mph [97 km/h])																	
Size	Load Range Ply Rating	Axle	Pressure in psi (kPa)														
			45 (311)	50 (345)	55 (380)	60 (414)	65 (448)	70 (483)	75 (517)	80 (552)	85 (586)	90 (621)	95 (655)	100 (689)	105 (724)	110 (758)	115 (793)
11–22.5	F–12	Front	—	—	—	4290	4530	4770	4990	5220	5430	5640	5840	6040	6240	6430	6610
		Rear	—	3760	3970	4180	4380	4580	4760	—	—	—	—	—	—	—	—
11–22.5	G–14	Front	—	—	—	4290	4530	4770	4990	5220	5430	5640	5840	6040	—	—	—
		Rear	—	3760	3970	4180	4380	4580	4760	4950	5120	5300	—	—	—	—	—

**Table 9.1, Tire Load Limits, Bias Ply Tubeless Tires, at Various Cold Inflation Pressures (maximum 60 mph [97 km/h])**

Tire Load Limits, Michelin Standard and Low Profile Radial Ply Tubeless Tires, at Various Cold Inflation Pressures (maximum 65 mph [105 km/h])																	
Size	Load Range Ply Rating	Axle	Pressure in psi (kPa)														
			45 (311)	50 (345)	55 (380)	60 (414)	65 (448)	70 (483)	75 (517)	80 (552)	85 (586)	90 (621)	95 (655)	100 (689)	105 (724)	110 (758)	115 (793)
9R–22.5	F–12	Front	—	—	2860	3090	3318	3503	3700	3913	4050	4308	4500	—	—	—	—
		Rear	—	—	2610	2840	3114	3261	3474	3671	3835	4050	4220	—	—	—	—
10R–22.5	F–12	Front	—	—	—	—	—	—	4255	4490	4725	4963	5150	—	—	—	—
		Rear	—	—	—	—	—	—	3914	4130	4349	4566	4740	—	—	—	—
10R–22.5	G–14	Front	—	—	—	—	—	—	4255	4490	4725	4963	5150	5430	5510	—	—
		Rear	—	—	—	—	—	—	3914	4130	4349	4566	4740	4995	5080	—	—
11R–22.5	G–14	Front	—	—	—	—	—	—	4693	4950	5215	5470	5755	6040	—	—	—
		Rear	—	—	—	—	—	—	4224	4550	4693	4923	5180	5440	—	—	—

# Pretrip Inspection and Daily Maintenance

Tire Load Limits, Michelin Standard and Low Profile Radial Ply Tubeless Tires, at Various Cold Inflation Pressures (maximum 65 mph [105 km/h])																	
Size	Load Range Ply Rating	Axle	Pressure in psi (kPa)														
			45 (311)	50 (345)	55 (380)	60 (414)	65 (448)	70 (483)	75 (517)	80 (552)	85 (586)	90 (621)	95 (655)	100 (689)	105 (724)	110 (758)	115 (793)
11R-22.5	H-16	Front Rear	— —	— —	— —	— —	— —	4693 4224	4950 4550	5215 4693	5470 4923	5755 5180	6040 5440	6245 5620	6428 5880	6610 5950	
235/80R 22.5	G-14	Front Rear	— —	— —	— —	— —	3593 3395	3815 3594	4035 3814	4278 4035	4543 4278	4675 4410	— —	— —	— —	— —	— —
255/70R 22.5	H-16	Front Rear	— —	— —	— —	— —	3385 3135	3598 3329	3810 3521	4023 3713	4235 3905	4448 4096	4652 4280	4805 4420	4940 4540	5273 4851	5510 5070
255/80R 22.5	G-14	Front Rear	— —	— —	— —	— —	— 3695	4000 3910	4235 3910	4465 4135	4710 4355	4960 4575	5205 4810	— —	— —	— —	— —
275/80R 22.5	H-14	Front Rear	— —	— —	— —	— —	4155 3680	4435 3920	4715 4168	4990 4425	5260 4675	5535 4930	5805 5175	6080 5415	6345 5650	6615 5883	6940 6175
275/80R 22.5	H-16	Front Rear	— —	— —	— —	— —	4155 3680	4435 3920	4715 4168	4990 4425	5260 4675	5535 4930	5805 5175	6080 5415	6345 5650	6615 5883	6940 6175

**Table 9.2, Tire Load Limits, Michelin Standard and Low Profile Radial Ply Tubeless Tires, at Various Cold Inflation Pressures (maximum 65 mph [105 km/h])**

# Pretrip Inspection and Daily Maintenance

Variations in Load and Inflation Limits According to Speed		
Speed Range mph (km/h)	Inflation Pressure Increase in psi (kPa)	Percent Increase/ Decrease in Load
70 to 75 (113 to 121)	10 (69)	-10
61 to 70 (98 to 113)	10 (69)	0
51 to 60 (82 to 97)	0	0
41 to 50 (66 to 80)	0	+9
31 to 40 (50 to 64)	0	+16
21 to 30 (34 to 48)	10 (69)	+24
11 to 20 (18 to 32)	15 (103)	+32

**Table 9.3, Variations in Load and Inflation Limits According to Speed**



## WARNING

**Do not operate the vehicle with underinflated or overinflated tires. Incorrect inflation can stress the tires and make the tires and rims more susceptible to damage, possibly leading to rim or tire failure and loss of vehicle control, resulting in serious personal injury or death.**

- 43.2 If a tire has been run flat or underinflated, check the wheel for proper locking and side

ring seating, and possible wheel, rim, or tire damage before adding air.

- 43.3 Moisture inside a tire can result in body ply separation or a sidewall rupture. During tire inflation, compressed air reservoirs and lines must be kept dry. Use well-maintained inline moisture traps and service them regularly.
- 43.4 Inspect the tires for bulges, cracks, cuts, or penetrations. A tire pressure check will assist in uncovering hidden damage. A weekly pressure loss of 4 psi (28 kPa) or more in a tire may indicate damage and the tire should be inspected and repaired or replaced.
- 43.5 Tires should also be inspected for oil contamination. Fuel oil, gasoline, and other petroleum derivatives, if allowed to contact the tires, will soften the rubber and destroy the tire.
- 43.6 If the tires are wearing irregularly, rotate them. If the front steering axle tires become irregularly worn, move them to the drive axle (**Fig. 9.15**). Have the front axle alignment checked to determine the cause of irregular tire wear. In a dual assembly, if one tire wears faster than its mate, reverse the position of the two tires. See **Fig. 9.16**.

# Pretrip Inspection and Daily Maintenance

- 43.7 Government regulations require the removal of front axle tires at 4/32-inch (3-mm) remaining tread depth and rear axle tires at 2/32-inch (1.5-mm) remaining tread depth. However, front axle tires may be rotated to the drive or trailer axles to use the remaining 2/32-inch (1.5-mm) tread rubber. See **Group 40** of the *Business Class® Trucks Service Manual* for additional information on tire matching, spacing of dual tires, and causes of abnormal tire wear.

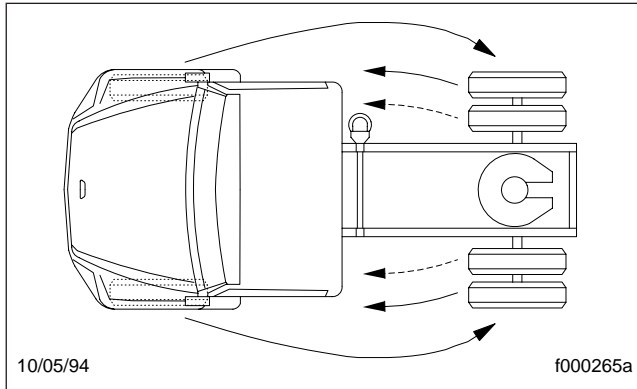

**Fig. 9.15, Front Axle to Rear Axle Rotation**

44. Check for indications of loose wheel nuts or rim nuts and examine each wheel component.

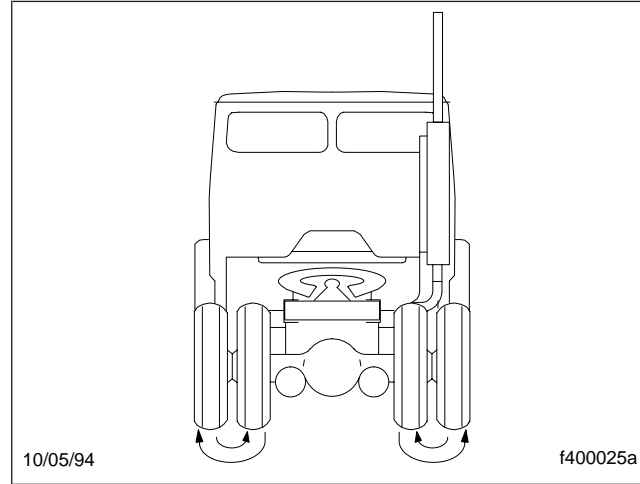

**Fig. 9.16, Dual Assembly Rotation**

Check the wheel nuts or rim nuts for indications of looseness. Remove all dirt and foreign material from the assembly. Dirt or rust streaks from the stud holes, metal buildup around stud holes, or out-of-round or worn stud holes, may be caused by loose wheel nuts. See **Group 40** of the *Business Class® Trucks Maintenance Manual* for torque specifications and the correct tightening sequence.

# Pretrip Inspection and Daily Maintenance

Examine the wheel assembly components (including rims, rings, flanges, studs, and nuts) for cracks, or other damage.

See **Group 33** and **Group 35** of the *Business Class® Trucks Service Manual* for service procedures on the studs and hubs and see **Group 40** of the *Business Class® Trucks Service Manual* for wheel and tire servicing. Replace broken, cracked, badly worn, bent, rusty, or sprung rings and rims. Be sure that the rim base, lockring, and side ring are matched according to size and type.

## WARNING

Have any worn or damaged wheel components replaced by a qualified person using the wheel manufacturer's instructions and the wheel industry's standard safety precautions and equipment. Otherwise a vehicle or workshop accident could occur, possibly resulting in serious personal injury or death.

## CAUTION

Insufficient wheel nut (rim nut) torque can cause wheel shimmy, resulting in wheel damage, stud breakage, and extreme tire tread wear. Excessive wheel nut torque can break studs, damage threads,

and crack discs in the stud hole area. Use the recommended torque values and follow the proper tightening sequence.

45. Check components of the air brake system for correct operation as follows:
- 45.1 Release the parking brakes on the vehicle by pushing in the parking brake control valve knob. Check the air governor cut-in and cut-out pressures. Run the engine at fast idle. The air governor should cut out the air compressor at approximately 125 psi (862 kPa). With the engine idling, make a series of foot valve applications. The air governor should cut in the air compressor at approximately 95 psi (655 kPa). If the air governor does not cut in and out as described above, it must be adjusted to these specifications. If the air governor cannot be adjusted or repaired, replace it before operating the vehicle.
- 45.2 Check the air pressure buildup time as follows:
- For vehicles without a trailer air brake hookup, release the parking brakes on the vehicle by pushing in the parking brake control valve knob.*

# Pretrip Inspection and Daily Maintenance

For vehicles with a trailer air brake hookup, release the parking brakes on the vehicle by pushing in the parking brake control valve knob. See Fig. 9.17. Apply the trailer parking brakes by pulling out the trailer air supply valve knob. See Fig. 9.17.

With the air system fully charged to 125 psi (862 kPa), make one full brake application and note the air pressure reading on the gauge. Continue to reduce the air pressure by moderate brake applications to a maximum of 90 psi (620 kPa), then run the engine at governed rpm. If the time required to raise the air pressure to 125 psi (862 kPa) (from the pressure noted after one brake application) is more than 30 seconds, eliminate any leaks or replace the air compressor before operating the vehicle.

- 45.3 Check the air pressure reserve. With the air system fully charged to 125 psi (862 kPa), stop the engine and note the air pressure. Then make one full brake application and observe the pressure drop. If it drops more than 25 psi (172 kPa), all areas of leakage must be eliminated before operating the vehicle.
- 45.4 Check the air leakage in the system (on vehicles with a trailer air brake hookup, charge

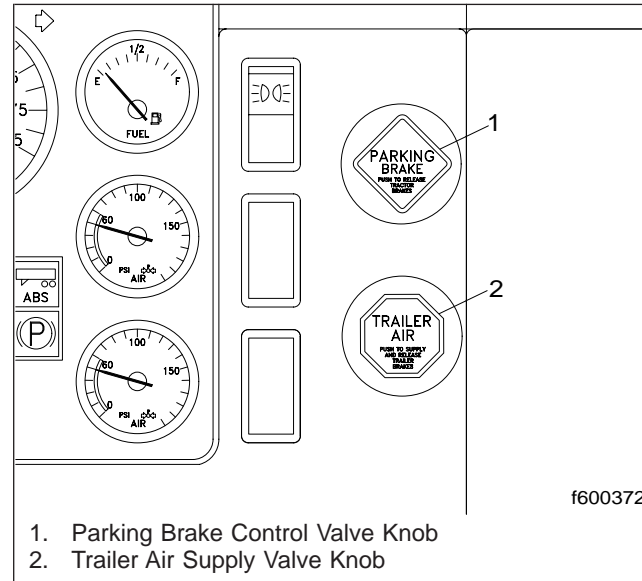

**Fig. 9.17, Parking Brake Valve and Trailer Air Supply Valve Knobs**

the trailer-brake system with air by pushing in the trailer air supply valve knob).

With the parking brakes applied, the transmission out of gear, and the tires chocked,

# Pretrip Inspection and Daily Maintenance

charge the air system until cutoff pressure of 125 psi (862 kPa) is reached.

With the service brakes released, shut down the engine, wait one minute and note the air pressure gauge reading. Observe the air pressure drop in psi (kPa) per minute.

Charge the air system until cutoff pressure of 125 psi (862 kPa) is reached. With the parking brakes released and the service brake applied, shut down the engine, wait one minute and note the air pressure gauge reading. Observe the air pressure drop in psi (kPa) per minute.

If leakage exceeds the limits shown in [Table 9.4](#), repair all areas of leakage before driving the vehicle.

Maximum Allowable Service Brake Air Leakage		
Description	Service Brakes Maximum Allowable Air Leakage in psi (kPa) Per Minute	
	Released	Applied
Truck or Tractor Only	2 (14)	3 (21)
Truck or Tractor w/Single Trailer	3 (21)	4 (28)

Maximum Allowable Service Brake Air Leakage		
Description	Service Brakes Maximum Allowable Air Leakage in psi (kPa) Per Minute	
	Released	Applied
Truck or Tractor w/Two Trailers	5 (35)	6 (42)

**Table 9.4, Maximum Allowable Service Brake Air Leakage**



**WARNING**

**Before operating the vehicle, be sure that the spring parking brakes on the tractor and the spring parking (or service) brakes on the trailer pass the above tests. Otherwise an unexpected parking brake application could occur, causing some loss of vehicle control and possibly resulting in serious personal injury.**

- 45.5 On vehicles with a trailer air brake hookup, check the spring parking brake system by pushing in the trailer air supply valve knob to release the trailer parking brakes. Pull the parking brake control valve knob out. The trailer air supply valve knob must pop out immediately and the tractor and trailer spring parking brakes must both apply.

# Pretrip Inspection and Daily Maintenance

---

With a fully charged air system of 125 psi (862 kPa), push in the parking brake control valve knob. The tractor spring parking brakes should release. Push the trailer air supply valve knob in.

With the trailer air system charged to 125 psi (862 kPa), the trailer brakes (spring parking brakes, if so equipped, or service brakes) should release.

Pull the trailer air supply valve knob out. The trailer brakes should apply.

**NOTE:** For trailers not equipped with spring parking brakes, the trailer service brakes automatically apply when the trailer air supply valve knob pops out.

## 46. *Test the service brakes before leaving the lot.*

When starting to move the vehicle and before picking up speed, test the brakes with the foot valve and parking brake valve to be sure that they will bring the vehicle to a safe stop.

If the vehicle has hydraulic brakes, depress the brake pedal, release the parking brake, and check that the brake system warning light goes off. If the warning light remains on after releasing the parking brake, correct the problem before driving off.

## 47. *Test the parking brakes on a 20-percent grade.*

Pull the parking brake control valve knob or apply the hand brake with the vehicle on a 20-percent grade. If the parking brakes do not hold the vehicle, repair the parking brake system.



# 10

## Cab Appearance

Cab Washing and Polishing .....	10.1
Care of Chromed Parts and Stainless-Steel Clad Parts .....	10.1
Dashboard Care .....	10.2
Vinyl Upholstery Cleaning .....	10.2
Cloth Upholstery Cleaning .....	10.3

# Cab Appearance

---

## Cab Washing and Polishing

To protect the finish of your new vehicle, follow these guidelines carefully:

- During the first 30 days, rinse your vehicle frequently with water. If the vehicle is dirty, use a mild liquid soap. Do not use detergent.
- During the first 30 days, do not use anything abrasive on your vehicle. Brushes, chemicals, and cleaners may scratch the finish.
- During the first 120 days, do not wax your vehicle.

To extend the life of your vehicle's finish, follow these guidelines:

- Avoid washing your vehicle in the hot sun.
- Always use water. After the cab is completely washed, dry it with a towel or chamois.
- Do not dust painted surfaces with a dry cloth, as this will scratch the paint.
- Do not remove ice or snow from a painted surface with a scraper of any sort.
- To prevent damage to the finish, wax it regularly. Before waxing, if the finish has become dull, remove oxidized paint using a cleaner specifically designed for this purpose. Remove all road tar and tree sap before waxing. Freightliner recom-

mends that a quality brand of cleaner or cleaner-polish and polishing wax be used.

- Do not let diesel fuel or antifreeze stand on a painted surface. If either should occur, rinse the surface off with water.
- To prevent rust, have any nicks or other damage on the finish touched up as soon as possible.
- Park your vehicle in a sheltered area whenever possible.

## Care of Chromed Parts and Stainless-Steel Clad Parts

To prevent rust, keep chrome and stainless-steel clad parts clean and protected at all times. This is especially important during winter driving and in coastal areas where there is exposure to salt air.

When cleaning chrome or stainless-steel clad parts, use clean water and a soft cloth or sponge. A mild detergent may also be used.

Sponge gently, then rinse. If necessary, use a nonabrasive chrome cleaner to remove stubborn rust or other material. Do not use steel wool.

**IMPORTANT:** Use only nonabrasive chrome cleaners on stainless-steel clad parts. This prevents scratching and marring of the polished surface.

To help protect the chrome after cleaning, apply a coat of polishing wax to the surface. Never use wax on parts that are exposed to high heat, such as exhaust pipes.

## Dashboard Care

Periodically wipe the dashboard with a water-dampened cloth. A mild detergent can be used, but avoid using strong detergents.



### CAUTION

**Do not use Armor-All Protectant®, STP Son-of-a-Gun®, or other equivalent treatments. These cleaners contain vinyl plasticizers which can cause stress crazing in the interior plastic panels which can result in cracking of the panels.**

## Vinyl Upholstery Cleaning

To prevent soiling, frequent vacuuming or light brushing to remove dust and dirt is recommended. Harsh cleaning agents can cause permanent damage to vinyl upholstery. To preserve the upholstery and prevent damage, carefully review the following sections for recommended cleaning procedures. Waxing or refinishing improves soil resistance and cleanability for all vinyls. Any hard wax, such as that used on automobiles, may be used.

## Ordinary Dirt

Wash the upholstery with warm water and mild soap, such as saddle or oil soap. Apply soapy water to a large area and allow to soak for a few minutes, then rub briskly with a cloth to remove the dirt. This can be repeated several times, as necessary.

If dirt is deeply imbedded, use a soft bristle brush after applying the soap.

If dirt is extremely difficult to remove, wall-washing preparations normally found around the home can be used. Powdered cleaners, such as those used for sinks and tiles, are abrasive and must be used with caution as they can scratch the vinyl or give it a permanent dull appearance.

## Chewing Gum

Harden the gum with an ice cube wrapped in a plastic bag, then scrape off with a dull knife. Any remaining traces of gum can be removed with an all-purpose light oil (peanut butter will also work) and wiped off.

## Tars, Asphalts, and Creosote

Each of these items stains vinyl after prolonged contact. They should be wiped off immediately and the area carefully cleaned, using a cloth dampened with naphtha.

# Cab Appearance

---

## Paint, Shoe Heel Marks

Paint should be removed immediately. Do not use paint remover or liquid-type brush cleaner on vinyl. An unprinted cloth, dampened with naphtha or turpentine may be used. Use care to prevent contact with parts of the upholstery that are not vinyl.

## Sulfide Stains

Sulfide compounds, such as those found in eggs and some canned goods, can stain after prolonged contact with vinyl. These stains can be removed by placing a clean, unprinted piece of cloth over the spotted area and pouring a liberal amount of six percent hydrogen peroxide onto the cloth.

Allow the saturated cloth to remain on the spot for 30 to 60 minutes. For stubborn spots, allow the hydrogen-peroxide saturated cloth to remain on the area overnight. Use caution to prevent the solution from seeping into the seams, or it will weaken the cotton thread.

## Nail Polish and Nail Polish Remover

Prolonged contact with these substances causes permanent damage to vinyl. Careful blotting immediately after contact minimizes damage. Do not spread the liquid during removal.

## Shoe Polish

Most shoe polishes contain dyes which penetrate vinyl and stain it permanently. Shoe polish should be wiped off as quickly as possible using naphtha or lighter fluid. If staining occurs, try the same procedure as that under "Sulfide Stains."

## Ball Point Ink

Ball point ink can sometimes be removed if rubbed immediately with a damp cloth, using water or rubbing alcohol. If this does not work, try the procedure used under "Sulfide Stains."

## Miscellaneous

If stains do not respond to any of the treatments described above, it is sometimes helpful to expose the vinyl to direct sunlight for up to 30 hours. Mustard, ball point ink, certain shoe polishes, and dyes often bleach out in direct sunlight, leaving the vinyl undamaged.

## Cloth Upholstery Cleaning

To prevent soiling, frequent vacuuming or light brushing to remove dust and dirt is recommended. Spot clean with a mild solvent or upholstery shampoo, or the foam from a mild detergent. When using a solvent or a dry-cleaning product, follow instructions carefully, and clean only in a well-ventilated area. Avoid any product that

contains carbon tetrachloride or other toxic materials. With either method, pretest a small area before proceeding. Use a professional upholstery cleaning service when extensive cleaning is needed.

## Grease and Oil-Based Stains

Dampen a small absorbent cloth with dry-cleaning solvent or spot remover. Apply carefully to the spot from the outer edge to the center. Pat and blot with a clean, dry cloth. Repeat several times, as necessary, turning cloths so that the stain does not redeposit on the fabric.

## Sugar and Water-Based Stains

Apply water-based detergent or cleaner, working in circular motions. Pat and blot as dry as possible. Repeat, if necessary, before drying thoroughly.

## Chewing Gum or Wax

Harden the gum or wax with an ice cube wrapped in a plastic bag, then scrape off with a dull knife. Excess wax can be absorbed by placing a thick white blotter over the wax and heating with a warm (not hot) iron. Remove the remainder by using the same procedure under "Grease and Oil-Based Stains."

## Mildew

Brush the dry fabric with a soft brush. Sponge with detergent, and blot. If the fabric is colorfast, dilute a teaspoon of bleach in one quart (one liter) of cool water. Apply with a swab, directly on the mildew stain. Dab repeatedly with clear, cool water, and blot dry.

## In an Emergency

Hazard Warning Lights .....	11.1
Towing .....	11.1
Emergency Starting With Jumper Cables .....	11.3
Fire in the Cab .....	11.4

# In an Emergency

## Hazard Warning Lights

The hazard warning light tab (**Fig. 11.1**) is located on the turn signal control lever. To operate the hazard lights, pull the tab out. All of the turn signal lights and both of the indicator lights on the control panel will flash.

To cancel the hazard warning lights, push the turn signal control lever either up or down, then return the lever to its neutral position.

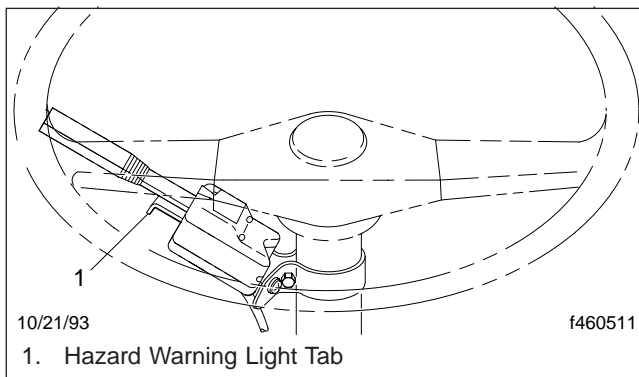

**Fig. 11.1, Hazard Warning Light**

## Towing

### **WARNING**

**Do not tow unbraked vehicles if the combined weight of both vehicles is more than the sum of the gross axle weight ratings (GAWRs) of the towing vehicle. Otherwise brake capacity will be inadequate, which could result in personal injury or death.**

**IMPORTANT:** When it is necessary to tow the vehicle, make sure the instructions below are closely followed to prevent damage to the vehicle.

### Front Towing Hookup

1. Disconnect the battery ground cable.
2. If the vehicle is to be lifted and towed, remove the drive axle shafts.

### **CAUTION**

**Failure to remove the axle shafts when towing the vehicle with the rear wheels on the ground could result in damage to the transmission and other parts.**

3. Cover the ends of the hubs with metal plates or plywood cut to fit the axle opening, and drilled to fit the axle shaft studs. This prevents lubricant from leaking out, and will keep contaminants from getting into the axle lubricant and damaging the wheel bearings.
4. Remove the bumper extension and chrome bumper, if installed.
5. Attach the towing device. Due to the many variables that exist in towing, positioning the lifting and towing device is the sole responsibility of the towing-vehicle operator, who must be familiar with standard towing industry safety measures.
6. Lift the vehicle, and secure the safety towing chains. If additional clearance is needed, remove the front wheels.
7. Connect the clearance lights, taillights, and signal lights. Connect any special towing lights required by local regulations.
8. If equipped with air brakes, connect the towing vehicle's air brake system to the vehicle being towed.



**Before releasing the parking brakes, make the connection to the towing vehicle, or chock the disabled vehicle's tires. Failure to do so could result in haz-**

**ardous conditions because the vehicle could suddenly roll and injury could occur.**

9. Release the parking brakes.

## Rear Towing Hookup



**Using a rear towing hookup on a vehicle equipped with a roof fairing could cause damage to the cab structure.**

**IMPORTANT:** Because of the possibility of excessive wind force which could cause damage to the cab, do not use a rear towing hookup on any vehicle equipped with a roof fairing.

1. Place the front tires straight forward, and secure the steering wheel in this position.
2. Disconnect the battery ground cable.
3. Attach the towing device. Due to the many variables that exist in towing, positioning the lifting and towing device is the sole responsibility of the towing-vehicle operator, who must be familiar with standard towing industry safety measures.



# In an Emergency

---

4. Lift the vehicle, and secure the safety towing chains. If additional clearance is needed, remove the bumper extension if equipped.
5. Connect the clearance lights, taillights, and signal lights. Also connect any special towing lights required by local regulations.

## Emergency Starting With Jumper Cables

When using jumper cables, follow the instructions below.



Vehicle batteries produce hydrogen gas and can create sparks, possibly leading to an explosion. Do not allow the vehicles to touch each other, and keep sparks, flames, cigarettes, etc. away from batteries. Do not lean over the batteries when making connections, and keep all other persons away from the batteries, otherwise severe personal injury could result from explosion and acid burns.



Make sure both starting systems have the same voltage outputs, and avoid making sparks. Other-

**wise the vehicle charging systems could be severely damaged. Also, do not attempt to charge isolated, deep-cycle batteries with jumper cables. Follow the manufacturer's instructions when charging deep-cycle batteries.**

NOTE: On vehicles equipped with an optional jump-start post, attach the positive cable clamp to that post instead of to the battery.

1. Apply the parking brakes and turn off the lights and all other electrical loads.
2. Connect an end of one jumper cable to the positive terminal of the booster battery (or jump-start post if equipped), and connect the other end of the cable to the positive terminal of the discharged battery (or jump-start post if equipped). See [Fig. 11.2](#).



Do the next step exactly as instructed, and do not allow the clamps of one cable to touch the clamps of the other cable, otherwise a spark could occur near a battery, possibly resulting in severe personal injury from explosion and acid burns.

3. Connect one end of the second jumper cable to the negative terminal of the booster battery, and connect the other end of the cable to a ground at least 12 inches (300 mm) away from the batteries of the

# In an Emergency

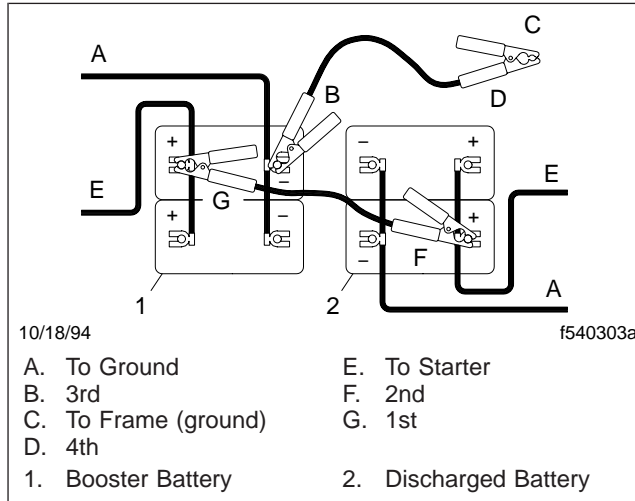

**Fig. 11.2, Jumper Connections**

vehicle needing the start. The vehicle frame is usually a good ground. Do *not* connect the cable to or near the discharged batteries.

4. Start the engine of the vehicle with the booster batteries, and let the engine run a few minutes to charge the batteries of the other vehicle.
5. Attempt to start the engine of the vehicle with the batteries receiving the charge. Do not operate the starter longer than 30 seconds, and wait at least

two minutes between starting attempts to allow the starter to cool.

6. When the engine starts, let it idle a few minutes.

## **WARNING**

**Do the next step exactly as instructed, and do not allow the clamps of one cable to touch the clamps of the other cable, otherwise a spark could occur near a battery, possibly resulting in severe personal injury from explosion and acid burns.**

7. Disconnect the grounded cable from the frame or other nonbattery location, then disconnect the other end of the cable.
8. Disconnect the remaining cable from the newly charged battery (or jump-start post if equipped) first, then disconnect the other end.

## Fire in the Cab

### **WARNING**

**Urethane foam is flammable! Do not allow any flames, sparks, or other heat sources such as cigarettes or light bulbs to contact urethane foam. Urethane foam in contact with such heat sources could**

# In an Emergency

---

**cause a serious, rapid fire, which could result in death, severe burns, or gas poisoning, as well as damage to the vehicle.**

The incidence of fire in heavy- and medium-duty trucks is rare, according to data from the National Highway Traffic Safety Administration. Federal Motor Vehicle Safety Standard #302 limits the flammability of specified materials used inside the cab, but despite this, most materials will burn. The cab of this vehicle contains urethane foam, which is of concern in this respect.

## In Case of a Cab Fire

As quickly as possible, bring the vehicle to a safe stop, apply the parking brake, turn off the ignition, and get out of the vehicle.

# Index

Subject	Page	Subject	Page	Subject	Page
<b>A</b>		<b>C</b>			
Air Brake System . . . . .	7.1	Cab Door Locks and Handles . . . . .	2.1	Cold Weather Operation . . . . .	4.19
General Information . . . . .	7.1	Cab Entry and Exit . . . . .	2.1	Caterpillar . . . . .	4.21
Meritor WABCO® Antilock Braking System (ABS), Air Brake Systems . . . . .	7.4	Cab Washing and Polishing . . . . .	10.1	Cummins . . . . .	4.22
Operation . . . . .	7.2	Canadian Motor Vehicle Safety Standard (CMVSS) Labels . . . . .	1.2	Detroit Diesel . . . . .	4.23
Trailer ABS Lamp Operation . . . . .	7.7	Care of Chromed Parts and Stainless-Steel Clad Parts . . . . .	10.1	General Information . . . . .	4.19
Aisin A581 Automatic Transmission . . . . .	5.39	Chrysler Automatic Transmissions . . . . .	5.36	Mercedes-Benz . . . . .	4.20
General Information, Aisin . . . . .	5.39	General Information, Chrysler . . . . .	5.36	Cold Weather Starting . . . . .	4.6
Operation, Aisin . . . . .	5.39	Operation, Chrysler . . . . .	5.36	Caterpillar . . . . .	4.6
Range Selections . . . . .	5.40	Overdrive Operation . . . . .	5.38	Cummins . . . . .	4.7
Allison Automatic Transmissions . . . . .	5.29	Torque Converter Clutch . . . . .	5.38	Mercedes-Benz . . . . .	4.6
General Information, MD Series . . . . .	5.34	When To Lock Out Overdrive . . . . .	5.38	Collision Warning System (CWS), Eaton VORAD EVT-300, Optional . . . . .	3.31
Operating Instructions, On- Highway Transmissions . . . . .	5.31	Cloth Upholstery Cleaning . . . . .	10.3	Driver Display Unit (DDU) . . . . .	3.32
Operation, MD Series . . . . .	5.35	Chewing Gum or Wax . . . . .	10.4	Failure Display Mode/Fault Codes . . . . .	3.39
Range Inhibit Indicator, 2000 and 2400 Series . . . . .	5.31	Grease and Oil-Based Stains . . . . .	10.4	In Case of Accident . . . . .	3.38
Safety Precautions, MD Series . . . . .	5.34	Mildew . . . . .	10.4	Maintenance and Diagnostics . . . . .	3.38
Safety Precautions, On-Highway Transmissions . . . . .	5.29	Sugar and Water-Based Stains . . . . .	10.4	Side Sensor Display, Optional . . . . .	3.36
		Clutches . . . . .	6.1	Special Road Situations . . . . .	3.36
		Clutch Adjustments . . . . .	6.3	Controls . . . . .	3.1
		Clutch Operation . . . . .	6.2	Air Horn, Optional . . . . .	3.18
		Eaton Valeo Clutch Break-In . . . . .	6.1	Air Suspension Dump Valve, Optional . . . . .	3.14
		General Information . . . . .	6.1	AirLiner Plus Suspension, Optional . . . . .	3.14
		Hydraulic Clutch Fluid Reservoir Checking . . . . .	6.4	Allison Automatic Transmission Controls . . . . .	3.17
		Lubrication . . . . .	6.4		
<b>B</b>					
Back-of-Cab Grab Handles, Steps, and Deck Plate . . . . .	2.22				
Bunk Mattress . . . . .	2.17				

Subject	Page	Subject	Page	Subject	Page
Caterpillar Electronic Engine Operator Control . . . . .	3.9	Vernier Throttle Control, Optional . . . . .	3.18	Operation, 9-Speed Models . . . . .	5.5
Cigarette Lighter, Optional . . . . .	3.16	Windshield Washer . . . . .	3.9	Operation, All Eaton Range-Shift Models . . . . .	5.4
Cummins Electronic Engine Operator Control . . . . .	3.11	Windshield Wipers . . . . .	3.7	Operation, Deep-Reduction Models . . . . .	5.9
Detroit Diesel Electronic Engine Control (DDEC) Operator Control . . . . .	3.12	Cruise Control . . . . .	4.16	Eaton Fuller Super 10 Models . . . . .	5.10
Dome Light Switches . . . . .	3.18			General Information, Super 10 . . . . .	5.10
Electric Horn . . . . .	3.18	<b>D</b>		Operation, Super 10 . . . . .	5.11
Hazard Warning Light Tab . . . . .	3.16	Dashboard Care . . . . .	10.2	Eaton® Fuller® Straight-Shift Transmissions . . . . .	5.1
Headlight Dimmer Switch . . . . .	3.16	Door Windows . . . . .	2.1	General Information, Straight-Shift . . . . .	5.1
Headlight Switch and Daytime Running Lights . . . . .	3.6			Operation, Straight-Shift . . . . .	5.2
Ignition Switch and Key . . . . .	3.1	<b>E</b>		Emergency Starting With Jumper Cables . . . . .	11.3
Interrupt Switch, Optional . . . . .	3.9	Eaton Fuller AutoSelect Automated Transmissions . . . . .	5.14	Engine Braking System, Optional . . . . .	4.27
Mirror Heat Switch, Optional . . . . .	3.1	General Information, AutoSelect . . . . .	5.14	Constant-Throttle Valves (MBE900 only) . . . . .	4.27
Panel Light Dimmer Switch . . . . .	3.1	Operation, AutoSelect . . . . .	5.15	Jacobs Engine Brake . . . . .	4.27
Parking Brake Control Lever . . . . .	3.15	Eaton Fuller AutoShift™ . . . . .	5.18	Engine Break-In . . . . .	4.7
Parking Brake Control Valve and Trailer Air Supply Valve . . . . .	3.13	Automatic Mode . . . . .	5.19	Caterpillar . . . . .	4.8
Parking Brake Control Valve . . . . .	3.15	Manual Mode . . . . .	5.20	Cummins . . . . .	4.8
Road Light Switch, Optional . . . . .	3.5	Push-Button Shift Selector . . . . .	5.18	Detroit Diesel . . . . .	4.8
Suspension Seat Adjustment Controls . . . . .	3.18	Selecting Gears, AutoShift . . . . .	5.20	Mercedes-Benz . . . . .	4.7
Tilt Steering Wheel . . . . .	3.18	Eaton Fuller Range-Shift Transmissions . . . . .	5.2	Engine Operation . . . . .	4.8
Turn Signal Lever . . . . .	3.16	General Information, Eaton Range-Shift . . . . .	5.2	Caterpillar . . . . .	4.10
Utility Light Switch, Optional . . . . .	3.6	Operation, 10-Speed Models . . . . .	5.6	Cummins . . . . .	4.12
		Operation, 13-Speed Models with Splitter . . . . .	5.7	Detroit Diesel . . . . .	4.13

# Index

Subject	Page	Subject	Page	Subject	Page
General Information . . . . .	4.8	Fifth Wheel Lock Mechanism for Trailer Kingpin . . . . .	8.7	Operation . . . . .	7.9
Mercedes-Benz . . . . .	4.9	Fifth Wheel Locking Operation . . . .	8.8	Trailer ABS Lamp Operation . . . .	7.11
Engine Shutdown . . . . .	4.24	Fifth Wheel Slide Operation . . . .	8.12		
Caterpillar . . . . .	4.25	General Information . . . . .	8.6	<b>I</b>	
Cummins . . . . .	4.26	Fuse/Relay/Circuit Breaker Identification . . . . .	2.17	Instrumentation Control Unit, Level I .	3.19
Detroit Diesel . . . . .	4.26			Level I ICU Ignition Sequence . . .	3.22
Mercedes-Benz . . . . .	4.24			Mode/Reset Switch . . . . .	3.23
Engine Starting . . . . .	4.1			Warning and Indicator Lights . . . .	3.20
Caterpillar . . . . .	4.3	<b>H</b>		Instruments and Controls Identification . . . . .	3.1
Cummins . . . . .	4.4	Hazard Warning Lights . . . . .	11.1	Instruments . . . . .	3.39
Detroit Diesel . . . . .	4.5	Heater and Air Conditioner . . . . .	3.44	Coolant Temperature Gauge . . . .	3.42
Mercedes-Benz . . . . .	4.2	Air Conditioning Using Fresh Air . .	3.48	Engine Oil Pressure Gauge . . . .	3.42
Pre-Start . . . . .	4.1	Defogging and Defrosting . . . . .	3.46	Fuel Gauge . . . . .	3.43
Starting Precautions, All Engines . .	4.2	Fresh Air . . . . .	3.50	Intake-Air Restriction Indicator . . .	3.43
EPA Vehicle Noise Emission Control Label . . . . .	1.3	Heating . . . . .	3.46	Primary and Secondary Air Pressure Gauges . . . . .	3.43
Exhaust Braking System, Optional . .	4.29	High Altitude Operation . . . . .	4.24	Speedometer . . . . .	3.39
General Information . . . . .	4.29	Holland Fifth Wheels . . . . .	8.1	Tachometer, Optional . . . . .	3.39
Pacbrake® Exhaust Brake . . . . .	4.31	Fifth Wheel Locking Operation . . . .	8.1	Transmission Oil Temperature Gauge, Optional . . . . .	3.44
<b>F</b>		General Information . . . . .	8.1	Voltmeter, Optional . . . . .	3.42
Federal Motor Vehicle Safety Standard (FMVSS) Labels . . . . .	1.1	Hood Tilting . . . . .	2.18		
Fire in the Cab . . . . .	11.4	To Return the Hood . . . . .	2.21	<b>M</b>	
In Case of a Cab Fire . . . . .	11.5	To Tilt the Hood . . . . .	2.20	Mercedes-Benz Manual Transmissions . . . . .	5.28
Fontaine Fifth Wheels . . . . .	8.6	Hydraulic Brake System . . . . .	7.8	Meritor Range-Shift Models . . . . .	5.21
		General Information . . . . .	7.8		
		Meritor WABCO® Antilock Braking System (ABS), Hydraulic Brake Systems . . . . .	7.9		

Subject	Page	Subject	Page	Subject	Page
General Information, Meritor Range-Shift . . . . .	5.22	Eaton Single Reduction Axles with Controlled Traction Differential . . . . .	6.7	Starting After Extended Shutdown or Oil Change . . . . .	4.7
Operation, Meritor Range-Shift . . . . .	5.22	Eaton Two-Speed Tandem Axles . . . . .	6.7	Steering System . . . . .	6.9
Meritor Splitter and Range-Shift Models . . . . .	5.25	Meritor Single-Drive Axles with Traction Equalizer . . . . .	6.4	General Information . . . . .	6.9
General Information, Splitter and Range-Shift . . . . .	5.25	Meritor Two-Speed Rear Axle . . . . .	6.5	Power Steering System . . . . .	6.9
Operation, Splitter and Range-Shift . . . . .	5.26				
		<b>S</b>		<b>T</b>	
<b>P</b>		Seat Belt Operation . . . . .	2.13	Tire and Rim Labels . . . . .	1.3
Power Takeoff (PTO) Governor . . . . .	4.18	Lap Belt . . . . .	2.15	Towing . . . . .	11.1
Detroit Diesel . . . . .	4.19	Three-Point Seat Belt with Komfort Latch . . . . .	2.13	Front Towing Hookup . . . . .	11.1
General Information . . . . .	4.18	Seat Belts and Tether Belts . . . . .	2.12	Rear Towing Hookup . . . . .	11.2
Pretrip Inspection and Daily Maintenance Procedures . . . . .	9.3	General Information . . . . .	2.12		
Pretrip Inspection Checklist . . . . .	9.1	Seats . . . . .	2.5	<b>U</b>	
		Bostrom Air-910 Seat . . . . .	2.9	Under Bunk Storage . . . . .	2.17
<b>R</b>		Bostrom Talladega 900 Seat . . . . .	2.10		
Rear Axles . . . . .	6.4	Dura-Form Seats . . . . .	2.11	<b>V</b>	
Eaton and Meritor Drive Axles with Main Differential . . . . .	6.6	Findlay Bench Seat . . . . .	2.12	Vehicle Specification Decal . . . . .	1.1
Eaton and Meritor Main Differential Lock Operation . . . . .	6.6	National Cush-N-Aire II Seat . . . . .	2.7	Vinyl Upholstery Cleaning . . . . .	10.2
Eaton Interaxle Differential Lockout Operation . . . . .	6.8	National Cush-N-Aire® Seat . . . . .	2.6	Ball Point Ink . . . . .	10.3
		National Easy-Aire Seat . . . . .	2.7	Chewing Gum . . . . .	10.2
		Sleeper Compartment Bunk Restraints . . . . .	2.16	Miscellaneous . . . . .	10.3
		Bunk Restraint Adjustment . . . . .	2.16	Nail Polish and Nail Polish Remover . . . . .	10.3
		Bunk Restraint Operation . . . . .	2.16	Ordinary Dirt . . . . .	10.2
		General Information . . . . .	2.16	Paint, Shoe Heel Marks . . . . .	10.3
				Shoe Polish . . . . .	10.3

# Index

---

<b>Subject</b>	<b>Page</b>
Sulfide Stains . . . . .	10.3
Tars, Asphalts, and Creosote . . . . .	10.2

## W

Warning and Indicator Lights, Right- Hand-Drive and Mechanical Engine Vehicles . . . . .	3.23
Bendix Antilock Braking System (ABS) . . . . .	3.30
Kysor Vehicle Protection System, Optional . . . . .	3.28
Meritor™ WABCO® Antilock Braking System (ABS), Air Brake Systems . . . . .	3.29
Meritor™ WABCO® Antilock Braking System (ABS), Hydraulic Brake Systems . . . . .	3.30
Standard Indicator Lights . . . . .	3.25
Standard Warning System . . . . .	3.25