



Run Smart™

ARGOSY®



Driver's Manual

Introduction

This manual provides information needed to operate and understand the vehicle and its components. More detailed information is contained in the *Owner's Warranty Information for North America* booklet, and in the vehicle's workshop and maintenance manuals.

Custom-built Freightliner vehicles are equipped with various chassis and cab components. Not all of the information contained in this manual applies to every vehicle. For details about components in your vehicle, refer to the chassis specification pages included in all new vehicles and to the component information label, located inside the vehicle.

For your reference, keep this manual in the vehicle at all times.

IMPORTANT: Descriptions and specifications in this manual were in effect at the time of printing. Freightliner Trucks reserves the right to discontinue models and to change specifications or design at any time without notice and without incurring obligation. Descriptions and specifications contained in this publication provide no warranty, expressed or implied, and are subject to revisions and editions without notice.

Environmental Concerns and Recommendations

Whenever you see instructions in this manual to discard materials, you should first attempt to reclaim and recycle them. To preserve our environment, follow appropriate environmental rules and regulations when disposing of materials.

Event Data Recorder

This vehicle is equipped with one or more devices that record specific vehicle data. The type and amount of data recorded varies depending on how the vehicle is equipped (such as the brand of engine,

if an air bag is installed, or if the vehicle features a collision avoidance system, etc.).

Customer Assistance Center

Having trouble finding service? Call the Customer Assistance Center at 1-800-385-4357 or 1-800-FTL-HELP. Call night or day, weekdays or weekends, for dealer referral, vehicle information, breakdown coordination, or Fleetpack assistance. Our people are knowledgeable, professional, and committed to following through to help you keep your truck moving.

© 2007–2015 Daimler Trucks North America LLC. All rights reserved. Daimler Trucks North America LLC is a Daimler company.

No part of this publication, in whole or part, may be translated, reproduced, stored in a retrieval system, or transmitted in any form by any means, electronic, mechanical, photocopying, recording, or otherwise, without the prior written permission of Daimler Trucks North America LLC. For additional information, please contact Daimler Trucks North America LLC, Service Systems and Documentation, P.O. Box 3849, Portland OR 97208–3849 U.S.A. or refer to www.Daimler-TrucksNorthAmerica.com and www.FreightlinerTrucks.com.

Contents

Chapter		Page
	Introduction, Environmental Concerns and Recommendations, Event Data Recorder, Customer Assistance Center	Foreword
1	Vehicle Identification	1.1
2	Vehicle Access	2.1
3	Electrical System	3.1
4	Instruments	4.1
5	Driver Controls	5.1
6	Climate Control	6.1
7	Seats and Restraints	7.1
8	Cab and Sleeper Features	8.1
9	Engine Starting, Operation, and Shutdown	9.1
10	Optional Engine Systems	10.1
11	Emissions Reduction Components	11.1
12	Brake System	12.1
13	Steering System	13.1
14	Manual Transmissions and Clutch	14.1
15	Automated Transmissions	15.1
16	Drive Axle Feature Operation	16.1
17	Fifth Wheels	17.1
18	Trailer Couplings	18.1
19	Headlight Aiming	19.1
20	Cab Appearance	20.1
21	In an Emergency	21.1
22	Pre- and Post-Trip Checklists	22.1
23	Pre- and Post-Trip Inspections and Maintenance	23.1
	Index	I.1

1

Vehicle Identification

Component Information Label	1.1
-----------------------------------	-----

Vehicle Identification

Component Information Label

The component information label lists the vehicle model, identification number, and major component models. It also lists the major assemblies and installations shown on the chassis specification sheet. The component information label is typically attached to the passenger-side dash. An illustration of the label is shown in **Fig. 1.1**.

FREIGHTLINER		COMPONENT INFORMATION		USE VEHICLE ID NUMBER WHEN ORDERING PARTS.	
MANUFACTURED BY	FREIGHTLINER LLC XXXXXXXXXXXXXXXXX 41 CHARACTERS XXXXXXXXXXXXXXXX				
MODEL	X 11 CHAR X	BASE MODEL	XX 12 CHAR X	DATE OF MFR	XX 13 CHAR XX
VEHICLE ID NO	X 17 CHARACTERS X	CUSTOMER	6 CHAR	WEEKBASE	XX 13 CHAR XX
ENGINE MOD	XXXXXXXXXXXXXXXXX 41 CHARACTERS XXXXXXXXXXXXXXXX			ENGINE NO	XXX 20 CHARACTERS XXX
MAIN TRANS MOD	012345678901234567890123456789012345678901	TRANS NO	0123456789012345678901	TIRES NO	0123456789012345678901
FIRE PUMP MOD	012345678901234567890123456789012345678901	FIRE PUMP NO	0123456789012345678901	FRONT AXLE NO	0123456789012345678901
FRONT AXLE MOD	012345678901234567890123456789012345678901	FRONT AXLE NO	0123456789012345678901	1ST INT AXLE NO	0123456789012345678901
1ST INT AXLE MOD	012345678901234567890123456789012345678901	1ST INT AXLE NO	0123456789012345678901	2ND INT AXLE NO	0123456789012345678901
2ND INT AXLE MOD	012345678901234567890123456789012345678901	2ND INT AXLE NO	0123456789012345678901	3RD INT AXLE NO	0123456789012345678901
3RD INT AXLE MOD	012345678901234567890123456789012345678901	3RD INT AXLE NO	0123456789012345678901	4TH INT AXLE NO	0123456789012345678901
4TH INT AXLE MOD	012345678901234567890123456789012345678901	4TH INT AXLE NO	0123456789012345678901	5TH INT AXLE NO	0123456789012345678901
5TH INT AXLE MOD	012345678901234567890123456789012345678901	5TH INT AXLE NO	0123456789012345678901	6TH INT AXLE NO	0123456789012345678901
6TH INT AXLE MOD	012345678901234567890123456789012345678901	6TH INT AXLE NO	0123456789012345678901	REAR AXLE NO	0123456789012345678901
REAR AXLE MOD	012345678901234567890123456789012345678901	REAR AXLE NO	0123456789012345678901	RATIO	0123456789012345678901
PAINT NFR	012345678901234567890123456789012345678901	FOR COMPLETE PAINT INFORMATION SEE VEHICLE SPECIFICATION SHEET.			
PAINT NUMBER	012345678901234567890123456789012345678901	L PART NO. 24-01176-010 REV A			
02/20/2012		f080176			

Fig. 1.1, Component Information Label

2

Vehicle Access

Door Locks and Handles	2.1
Cab Access, Fixed Steps	2.1
Cab Access, Mobile Stairs	2.4
Back-of-Cab Access	2.7
Opening the Grille	2.8
Cab Tilt System	2.9

Vehicle Access

Door Locks and Handles

One common key operates the ignition switch and all of the door locks.

IMPORTANT: Each key is numbered. Record the number so a duplicate key can be made, if needed.

To unlock the right-hand door from outside the cab, insert the key in the lock and turn it one-quarter turn counterclockwise. Turn the key to the original position to remove it. See [Fig. 2.1](#).

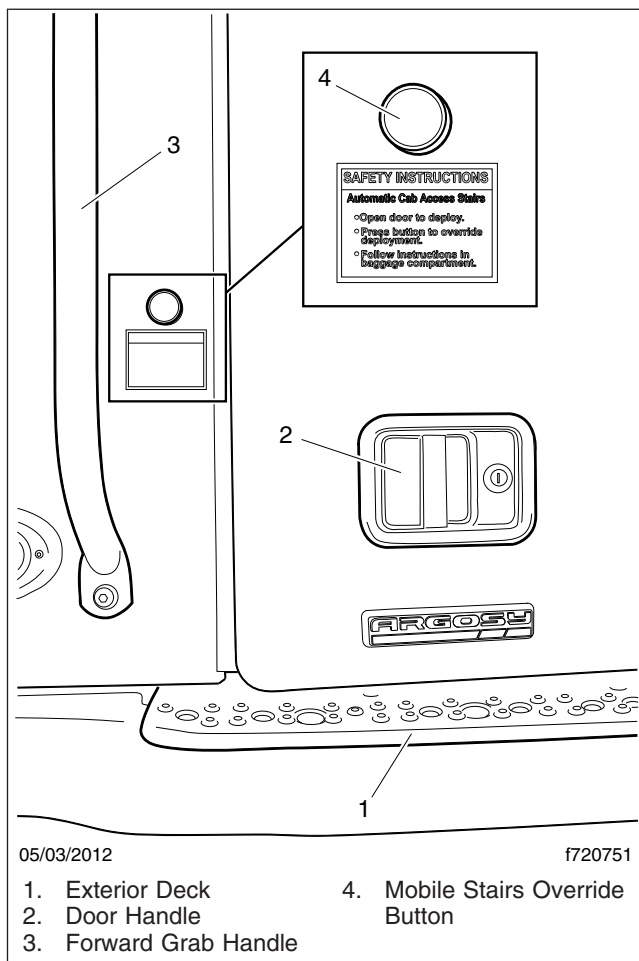

Fig. 2.1, Door Exterior (right side shown)

To unlock the left-hand door from outside the cab, insert the key in the lock and turn it one-quarter turn clockwise. Turn the key counterclockwise to the original

position to remove it. Pull out on the paddle handle to open the door.

NOTE: The cab door locks can be operated when the doors are open.

To lock a door from outside the cab, insert the key in the lock and turn it opposite the unlocking direction (counterclockwise for the left-hand door, clockwise for the right-hand door). See [Fig. 2.2](#).

To lock a door from inside the cab, push the lock knob down or press the automatic lock button on the door armrest, depending on what the vehicle is equipped with. See [Fig. 2.2](#). To unlock the door from inside, pull the lock knob up or press the unlock button on the door armrest, depending on what the vehicle is equipped with.

Cab Access, Fixed Steps

WARNING

Wet or dirty shoes greatly increase the chance of slipping or falling. If your shoes are wet or dirty, be especially careful when entering or exiting the vehicle.

Always maintain three-point contact with the vehicle when entering or exiting the cab. Three-point contact means both feet and one hand, or both hands and one foot.

Do not jump from the vehicle.

The grab handles, access steps, and steering wheel are all part of the cab access system. Use these "helping hands" when getting into or out of the cab to increase your security and comfort.

Left Side Entry

1. Open the left-hand door and place anything that you are carrying in the cab.
2. Grasp the aft grab handle with your right hand and the forward grab handle with your left hand. See [Fig. 2.3](#).
3. Place your right foot on the bottom step and pull yourself up.
4. Place your left foot on the middle step, reaching higher on both grab handles.

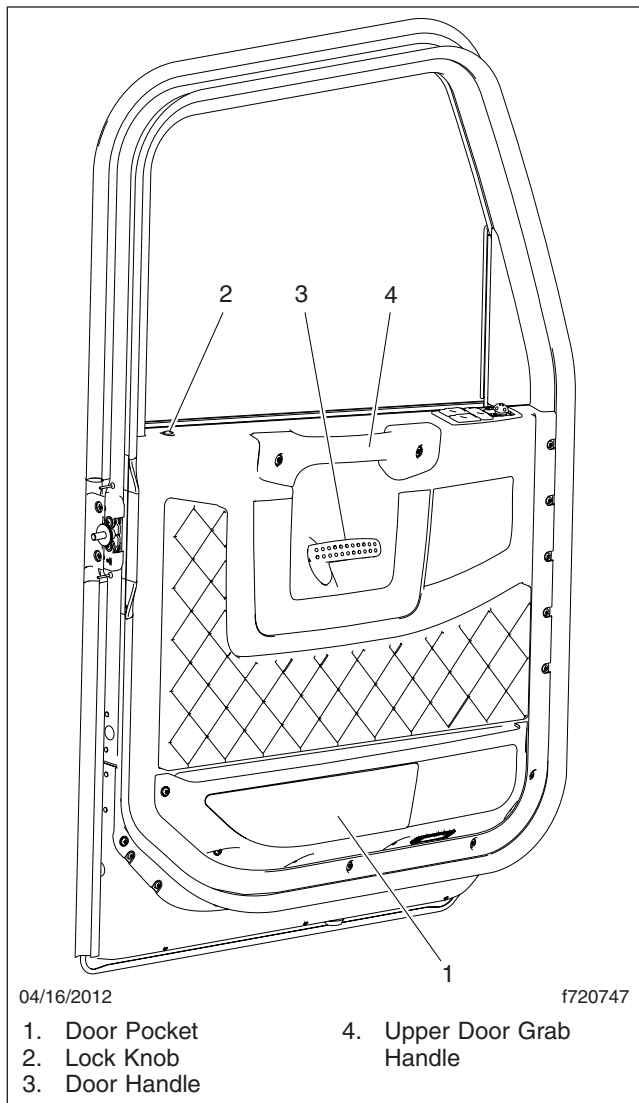

Fig. 2.2, Door Interior

5. Place your right foot on the top step and pull yourself up.

NOTE: The left side of the cab is equipped with an A-pillar grab handle or the steering wheel, depending on whether the vehicle is left-hand drive (LHD) or right-hand drive (RHD).

6. Move your right hand to the forward grab handle and your left hand to the steering wheel or A-pillar grab handle, then place your left foot on the deck.

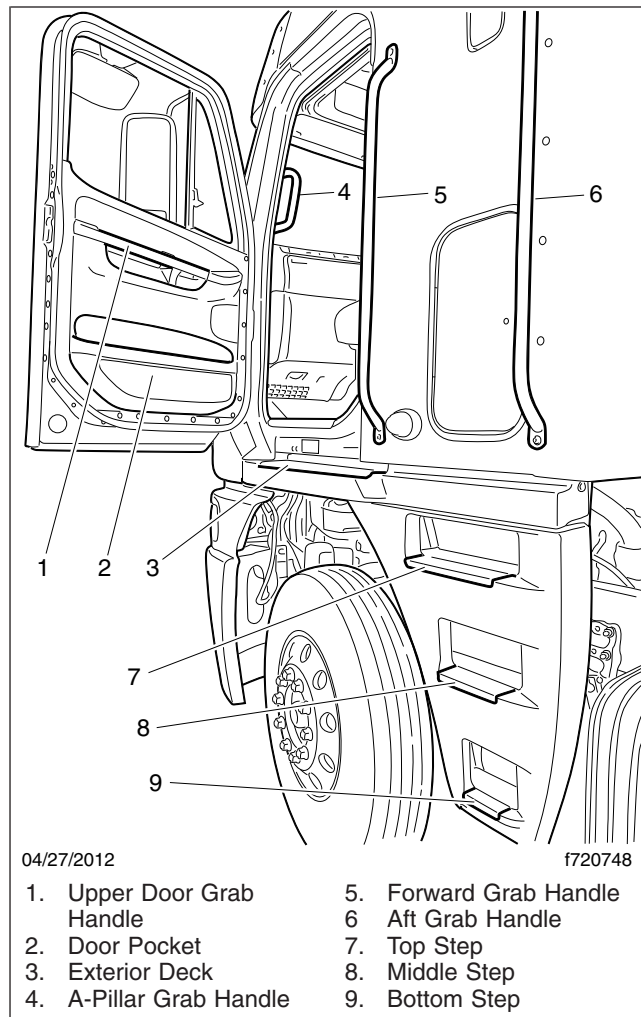

Fig. 2.3, Fixed Steps and Grab Handles, Left Side (RHD shown)

7. Step into the cab with your right foot first.

Left Side Exit

IMPORTANT: Do not attempt to exit the cab while carrying any items in your hands.

1. If you take items with you, place them in an accessible location on the seat or cab floor. Make sure they will not get in your way as you exit.

WARNING

Always face in when exiting the cab. Do not attempt to exit with your back to the cab, as you

Vehicle Access

would going down a flight of stairs. It is easier to slip or lose your balance. If you slip when exiting in this way, there is a greater likelihood of personal injury.

NOTE: The left side of the cab is equipped with an A-pillar grab handle or the steering wheel, depending on whether the vehicle is LHD or RHD.

2. Grasp the steering wheel or A-pillar grab handle with your left hand, place your right hand on the forward sidewall grab handle, and place both feet on the deck, facing into the cab.
3. Grasp the forward grab handle with your left hand and move your right hand to the aft grab handle.
4. Move your right foot to the top step.
5. Move your left foot to the middle step and lower your hands on both grab handles.
6. Move your right foot to the bottom step.
7. Step to the ground with your left foot first.

Right Side Entry

1. Open the right-hand door and place anything that you are carrying in the cab.
2. Grasp the aft sidewall grab handle with your left hand and the forward grab handle with your right hand. See [Fig. 2.4](#).
3. Place your left foot on the bottom step and pull yourself up.
4. Place your right foot on the middle step, reaching higher on both grab handles.
5. Place your left foot on the top step and pull yourself up.

NOTE: The right side of the cab is equipped with an A-pillar grab handle or the steering wheel, depending on whether the vehicle is LHD or RHD.

6. Move your left hand to the forward grab handle and your right hand to the steering wheel or A-pillar grab handle, then place your right foot on the deck.
7. Step into the cab with your left foot first.

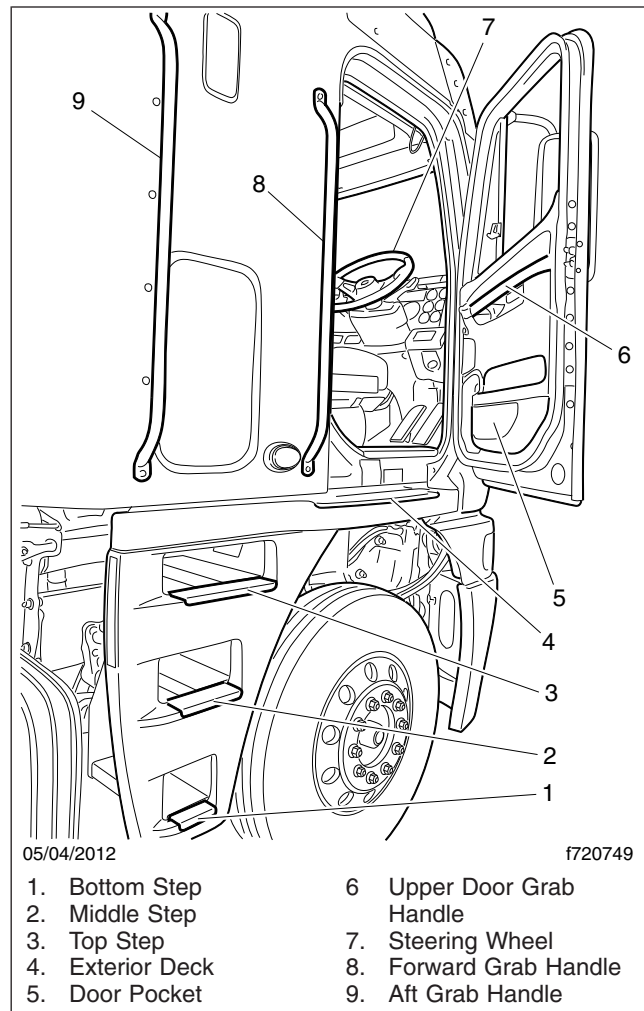

Fig. 2.4, Fixed Steps and Grab Handles, Right Side (RHD shown)

Right Side Exit

IMPORTANT: Do not attempt to exit the cab while carrying any items in your hands.

1. If you take items with you, place them in an accessible location on the seat or cab floor. Make sure they will not get in your way as you exit.

WARNING

Always face in when exiting the cab. Do not attempt to exit with your back to the cab, as you would going down a flight of stairs. It is easier to slip or lose your balance. If you slip when exiting

in this way, there is a greater likelihood of personal injury.

NOTE: The right side of the cab is equipped with an A-pillar grab handle or the steering wheel, depending on whether the vehicle is LHD or RHD.

2. Grasp the steering wheel or A-pillar grab handle with your right hand, place your left hand on the forward sidewall grab handle, and place both feet on the deck, facing into the cab.
3. Grasp the forward grab handle with your right hand and move your left hand to the aft grab handle.
4. Move your left foot to the top step.
5. Move your right foot to the middle step and lower your hands on both grab handles.
6. Move your left foot to the bottom step.
7. Step to the ground with your right foot first.

Cab Access, Mobile Stairs



Wet or dirty shoes greatly increase the chance of slipping or falling. If your shoes are wet or dirty, be especially careful when entering or exiting the vehicle.

Always maintain three-point contact with the vehicle when entering or exiting the cab. Three-point contact means both feet and one hand, or both hands and one foot.

Do not jump from the vehicle.

The grab handles, access steps, and steering wheel are all part of the cab access system. Use these "helping hands" when getting into or out of the cab. They will increase your security and comfort.

The mobile stairs will deploy when the cab door is opened. As the stairs deploy, an audible alert sounds outside the vehicle. If anything prevents deployment of the stairs, a buzzer will sound and an indicator will illuminate on the dash.

The cab stairs will not operate under the following conditions:

- parking brake is not set

- vehicle is in motion (stairs automatically stow if the vehicle begins to move)
- sensors detect weight on the stairs
- cab is tilted
- an obstacle is encountered in the stair travel path
- the disable button is pressed

To prevent deployment of the stairs from outside the vehicle, press the button on the side of the cab, directly above the stairs, before opening the door. See [Fig. 2.1](#).

To prevent deployment of the stairs from inside the cab, press the dash rocker switch labeled RH STEP or LH STEP while opening the cab door. See [Fig. 2.5](#).

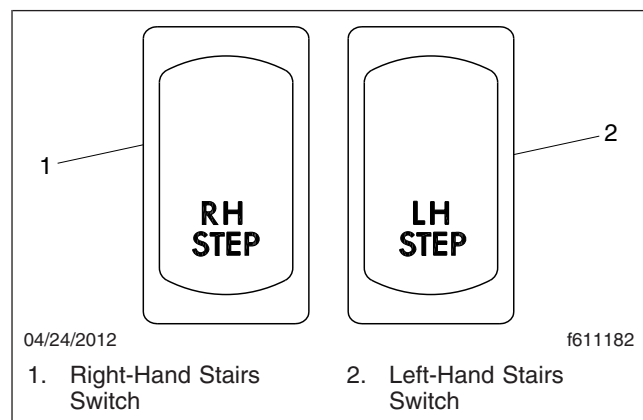

Fig. 2.5, Mobile Stairs Deployment Switches

NOTE: Pressing the disable button or switch will disable the stairs for one cycle of opening and closing the door. You must press the disable button each time you want to prevent deployment of the stairs.

Left Side Entry

1. Open the left-hand door and place anything that you are carrying in the cab.
2. Grasp the aft grab handle ([Fig. 2.6](#)) with your right hand and grab the forward grab handle with your left hand, reaching up as far as is comfortable.
3. Place your right foot on the bottom step and pull yourself up.

Vehicle Access

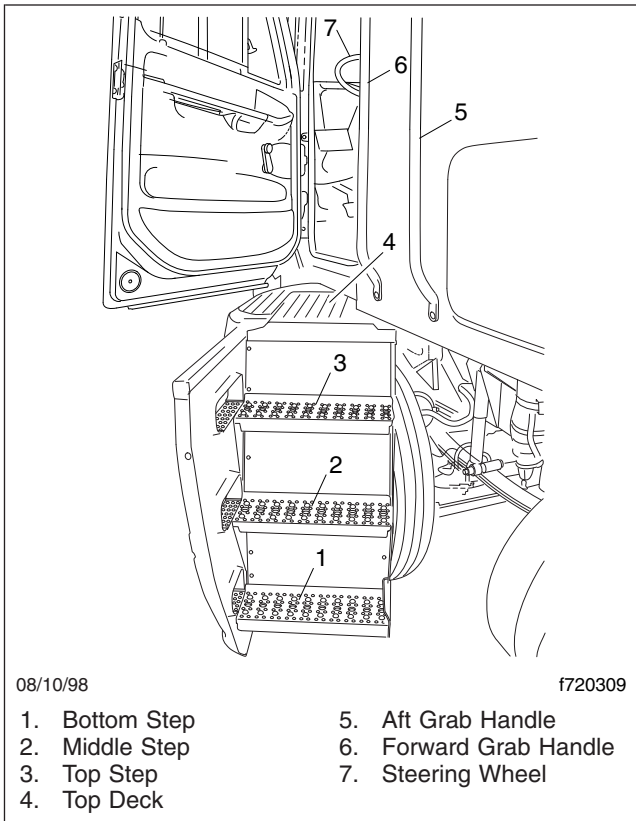

Fig. 2.6, Mobile Stairs, Left-Hand Side

4. Place your left foot on the middle step and pull yourself up.
5. Move your left hand to the forward grab handle, then place your left foot on the top step.

NOTE: The left side of the cab is equipped with an A-pillar grab handle or the steering wheel, depending on whether the vehicle is LHD or RHD.

6. Pull yourself up and place your right foot on the top deck and move your left hand to the A-pillar grab handle or steering wheel.
7. Move your right hand to the steering wheel or A-pillar grab handle.
8. With both hands gripping the steering wheel or A-pillar grab handle, move your right foot into the cab.

Left Side Exit

IMPORTANT: Do not attempt to exit the cab while carrying any items in your hands.

NOTE: The left side of the cab is equipped with an A-pillar grab handle or the steering wheel, depending on whether the vehicle is LHD or RHD.

1. Grasp the steering wheel or A-pillar grab handle with both hands, and stand on the deck at the top of the stairs facing into the cab.
2. With your right hand, grasp the forward grab handle.
3. Move your right foot to the top step.
4. Move your left hand to the forward grab handle and move your left foot to the middle step.
5. Move your right hand to the aft grab handle and move your right foot to the bottom step.
6. Step to the ground with your left foot.

Right Side Entry

1. Open the right-hand door and place anything that you are carrying in the cab.
2. Grasp the aft grab handle with your left hand and grab the forward grab handle with your right hand, reaching up as far as you're comfortable. See [Fig. 2.7](#).
3. Place your left foot on the bottom step and pull yourself up.
4. Place your right foot on the middle step and pull yourself up.
5. Move your right hand to the forward grab handle, then place your right foot on the top step.

NOTE: The right side of the cab is equipped with an A-pillar grab handle or the steering wheel, depending on whether the vehicle is LHD or RHD.

6. Pull yourself up and place your left foot on the top deck and move your right hand to the A-pillar grab handle or steering wheel.
7. Move your left hand to the steering wheel or A-pillar grab handle.

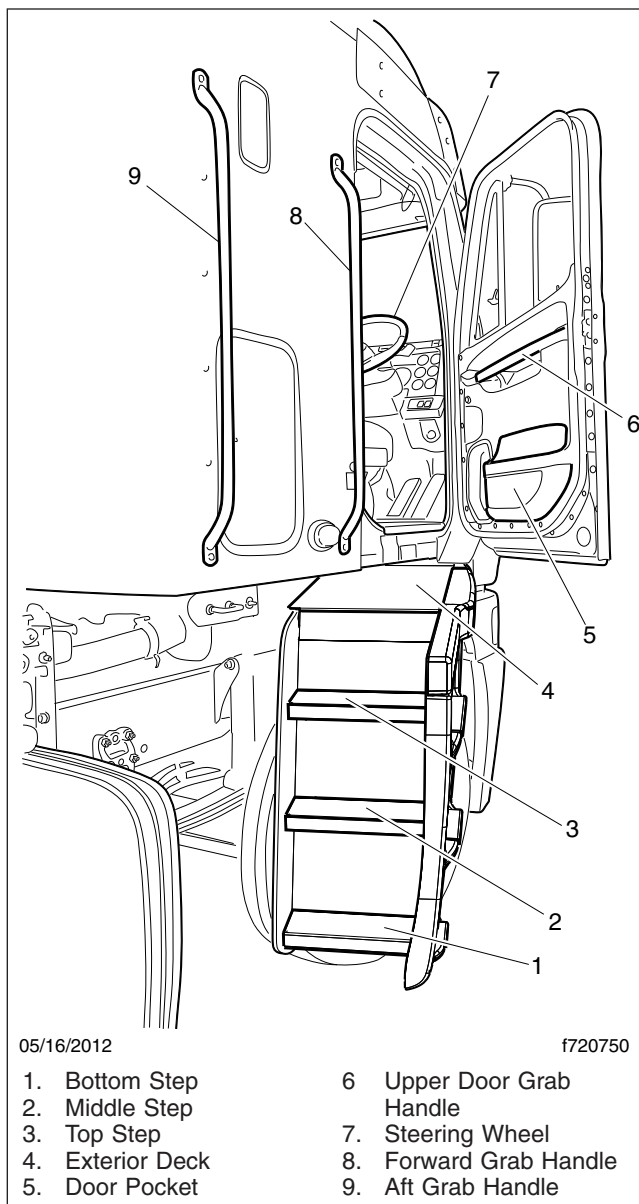

Fig. 2.7, Mobile Stairs and Grab Handles, Right-Hand Side (RHD shown)

8. With both hands gripping the steering wheel or A-pillar grab handle, move your left foot into the cab.

Right Side Exit

IMPORTANT: Do not attempt to exit the cab while carrying any items in your hands.

NOTE: The right side of the cab is equipped with an A-pillar grab handle or the steering wheel, depending on whether the vehicle is LHD or RHD.

1. Grasp the steering wheel or A-pillar grab handle with both hands, and stand on the deck at the top of the stairs facing into the cab.
2. With your left hand, grasp the forward grab handle.
3. Move your left foot to the top step.
4. Move your right hand to the forward grab handle and move your right foot to the middle step.
5. Move your left hand to the aft grab handle and move your left foot to the bottom step.
6. Step to the ground with your right foot.

Mobile Stair Lock-Up Procedures

Access Stairs Will Not Fully Deploy

1. Close the cab door.
2. Ensure the parking brake is set.
3. Inspect for an obstruction in the travel path of the steps.
4. Start the engine to increase battery voltage.
5. If the vehicle is parked at an incline greater than 3.5 degrees in any direction, move it to a level surface (if conditions permit).
6. Open the door again. If the steps will not fully deploy, but will return to a fully stowed position, press the RH STEP or LH STEP switch while opening the cab door.
7. Enter and exit the cab using the access instructions for fixed steps.

Access Stairs Will Not Fully Stow

1. Open and close the door.
2. Inspect for an obstruction in the travel path of the steps.
3. Start the engine to increase battery voltage.
4. If the vehicle is parked at an incline greater than 3.5 degrees in any direction, move it to a level surface (if conditions permit).

Vehicle Access

5. Open and close the door again. If the steps still will not stow, leave the door open and exit the cab from the opposite side.
6. Place a hand on the exterior surface of the step, then apply light pressure to the step while closing the door.
7. If the step stows, press the yellow disable button next to the grab handle. This will disable the step for cycle of opening and closing the door.
8. If the steps will not fully stow, follow the instructions on the inside of the baggage door to safely stow the steps.

Back-of-Cab Access

Grab handles are typically located on the backwall of the cab or sleeper, or on the inside of the cab extender, if equipped. See **Fig. 2.8**. A grab handle may also be provided on the exhaust stack. Steps may be mounted on the fuel tank(s), battery or tool box(es), or on metal brackets secured to the frame rail. A deck plate is mounted across the top of the frame rails. All other areas are not meant to support back-of-cab access.

WARNING

Follow these rules for back-of-cab access. Failing to follow these rules could lead to a fall, and possible personal injury.

Never step on any exterior part unless it has a slip-resistant surface meant for safe stepping. If the surface is movable, such as a battery box cover with a slip-resistant surface, be certain it is firmly secured.

Be careful not to trip on items such as chains or air lines in the back-of-cab area.

Always follow safety procedures for back-of-cab access, maintaining three-point contact—both hands and one foot, or both feet and one hand—whenever moving around, and always face in toward the deck plate when climbing up or down.

Wet or dirty shoes, steps, or grab rails greatly increase the chance of slipping or falling. If your shoes or the contact areas are wet or dirty, clean and dry them as much as possible before accessing the back of cab area, and be especially careful when climbing or standing on the vehicle.

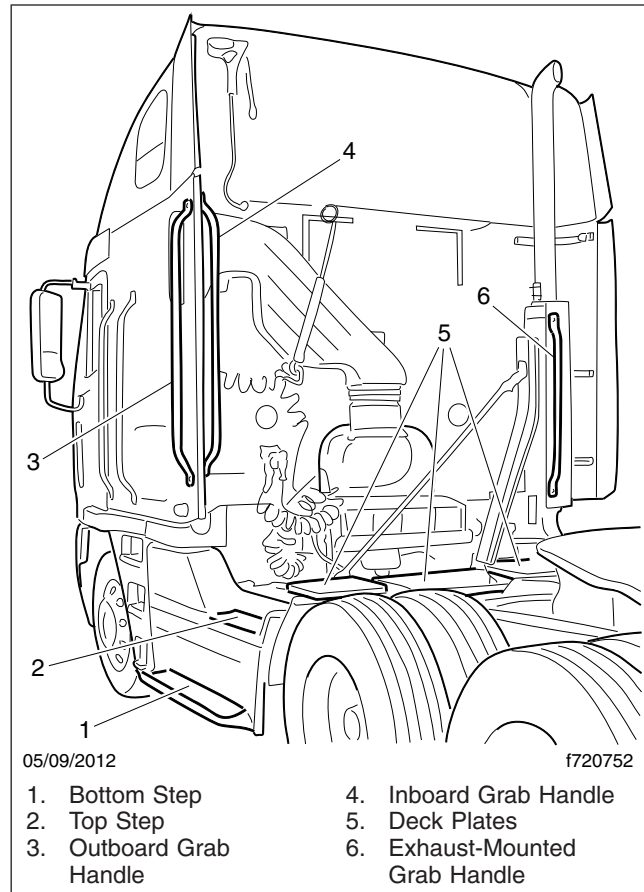

Fig. 2.8, Back-of-Cab Access

Never jump onto, or off of, a vehicle; doing so creates a very high likelihood of a fall and personal injury.

Wet or dirty shoe soles greatly increase the chance of slipping or falling. If your soles are wet or dirty, be especially careful when accessing the back-of-cab area.

Be careful not to get hands or feet tangled in hoses or other back-of-cab equipment. Carelessness could cause a person to trip and fall, with possible injury.

Accessing Back-of-Cab Area

WARNING

External surfaces of the exhaust system remain hot after the engine has been shut down. When accessing the back of the cab or sleeper, do not

touch any part of the exhaust system other than the exhaust-mounted grab handle, if equipped, or severe burns could occur.

1. Facing the center of the deck plate, grasp the grab handle with both hands. Reach up as far as is comfortable.
2. Place one foot on the bottom step and pull yourself up.
3. Place your other foot on the top step.
4. Move your lower hand to a higher position on the grab handle.
5. Step onto the deck plate.

Exiting the Back-of-Cab Area

1. Face the center of the vehicle and grasp the grab handle with both hands.
2. Place one foot at a time on the top step.
3. Move your upper hand to a lower position on the grab handle.
4. Move one foot to the bottom step.
5. Step to the ground with your upper foot first.

Opening the Grille



CAUTION

Step back from the grille when opening it. The grille can open quickly and could hit a person, possibly resulting in personal injury.

Opening the grille allows the driver access to the engine oil dipstick, the coolant fill cap, and the windshield washer reservoir. To open the grille, face the front of the truck, reach through the latch access openings on either side of the grille, and release the two latches. See [Fig. 2.9](#). Grip the grille firmly with both hands and lift. Pull the interior straps down to pull the grille shut. See [Fig. 2.10](#).

Make sure the grille is shut and latched securely.

NOTE: On some vehicles, the access latches are located behind the lower corners of the grille.

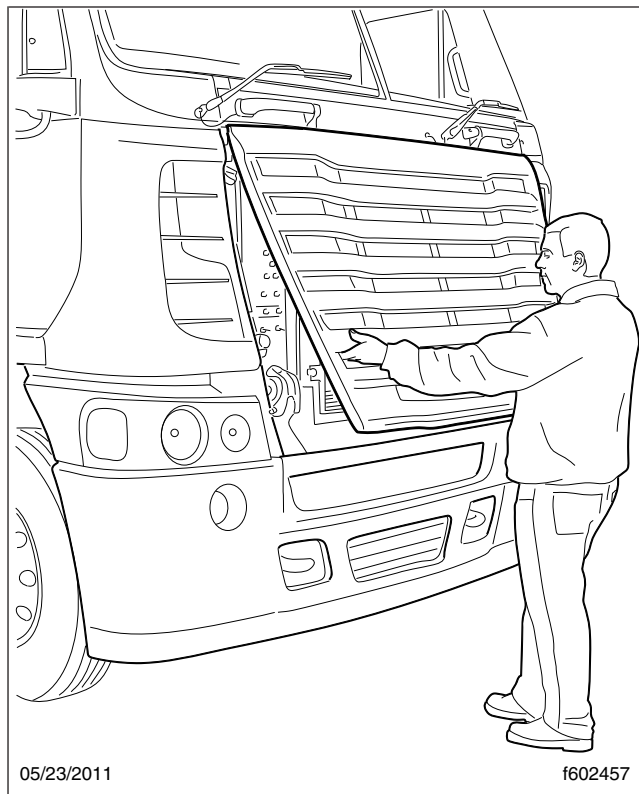
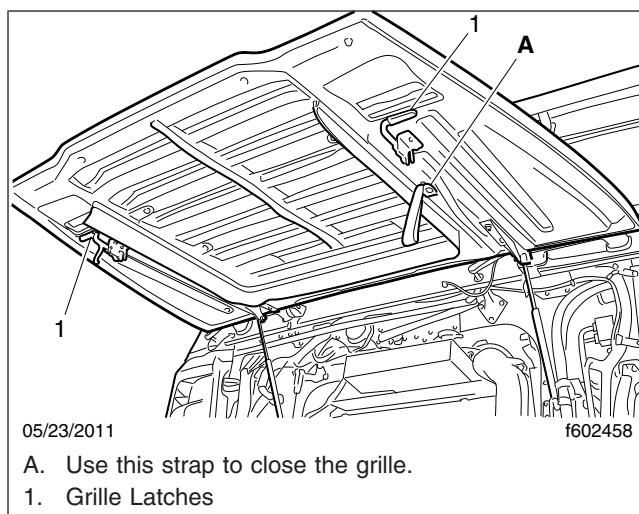

Fig. 2.9, Opening the Grille



05/23/2011

f602458

A. Use this strap to close the grille.

1. Grille Latches

Fig. 2.10, Grille (shown fully open)

Vehicle Access

Cab Tilt System

The hydraulic tilt system is used to tilt and lower the cab. An electric motor is used to activate the hydraulic tilt pump. The tilt pump can also be operated manually if necessary. A pump handle is located in the baggage compartment for manually working the tilt pump.

The hydraulic cab latches open automatically when the cab is tilted. When the cab is returned to the operating position, the latch hooks lock automatically. An indicator pin on the outboard side of each latch protrudes when the latch is unlocked, and recedes when the latch is locked. See [Fig. 2.11](#).

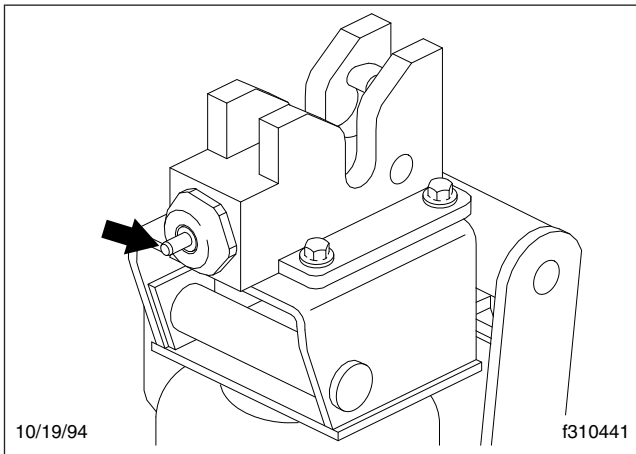

Fig. 2.11, Indicator Pin

NOTICE

Do not use either the telescoping tube assembly or the hydraulic tilt cylinder as a step or handhold; you could damage the transmission, telescoping tube assembly, or the tilt cylinder.

Tilting the Cab

WARNING

Before tilting the cab, make sure there is adequate clearance in front of the vehicle and that the area is free of people and objects.

Do not tilt the cab with the engine running. Tilting the cab could engage the transmission. If the engine is running, the vehicle could move, caus-

ing an accident that could result in personal injury or property damage.

The hydraulic tilt system is a cab-tilting, not a cab-holding device. Do not leave the vehicle unattended unless the cab is fully tilted or resting against the safety stop. Holding the cab in place with the hydraulic tilt system may result in personal injury or death and/or property damage.

IMPORTANT: Before tilting or lowering the cab, read the warning label on the tilt pump and the tilt instructions label on the exhaust stack.

NOTICE

Before tilting the cab, make sure the vehicle is parked on level ground, both side-to-side and fore-to-aft. Tilting the cab while the vehicle is parked on a slope may damage the cab mounts and prevent you from returning the cab to the operating position.

1. Park the vehicle on a level surface, place the vehicle in neutral, shut down the engine, and set the parking brake. Chock the tires.

WARNING

Objects falling in the cab or a door flying open could damage the vehicle or cause personal injury.

2. Secure all loose articles in the cab and bunk, then activate the tilt system power switch on the dash. See [Fig. 2.12](#).

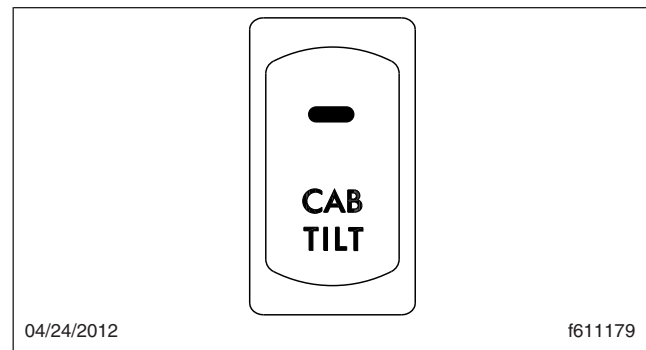

Fig. 2.12, Cab Tilt Switch

3. Exit the cab and make sure the doors are fully latched.

NOTICE

Make sure the grille is open before tilting the cab (vehicles built from June 2011). Leaving the grille closed while tilting the vehicle will cause damage to the grille.

IMPORTANT: Vehicles built February 2012 and later are equipped with a safety mechanism that prevents the tilt pump from operating when the grille is not open.

4. Fully open the grille.
5. Check the cab travel path for obstructions.
6. Move the pump control lever to the TILT position. See [Fig. 2.13](#).

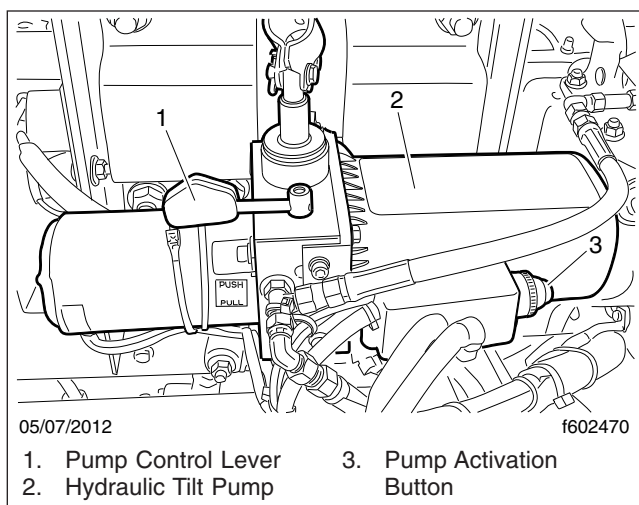

Fig. 2.13, Cab Tilt Pump

7. Press and hold the button on the pump to disengage the hold-down latches and begin tilting the cab.

IMPORTANT: Check the indicator pin on each cab latch. The latches have disengaged if the pins are out. See [Fig. 2.11](#).

DANGER

Make sure the safety stop is engaged on the right tilt cylinder rod. If the safety stop isn't engaged, and the cab should drop, the result could be serious injury or death.

8. When the cab reaches a 30-degree angle, stop tilting the cab by letting go of the pump button. Engage the safety stop on the right tilt cylinder rod. See [Fig. 2.14](#). The safety stop prevents the cab from accidentally dropping below this position.

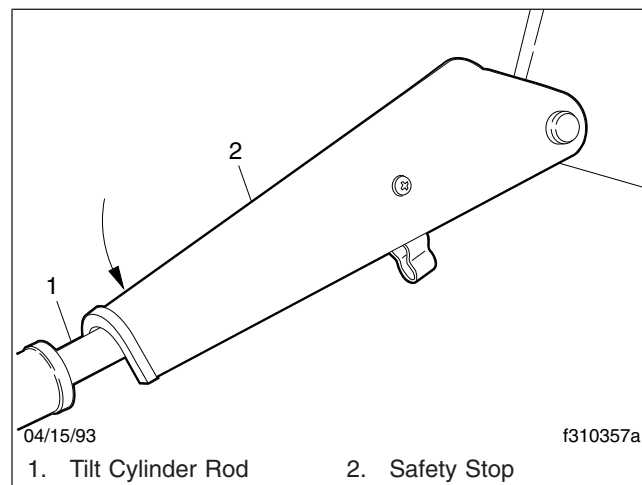

Fig. 2.14, Safety Stop Engaged

9. To tilt the cab all the way, press and hold the button on the pump until the cab nears a 45-degree angle (the balance point). See [Fig. 2.15](#). Once the cab goes beyond 45 degrees, release the button on the pump and move the tilt pump lever to the RETURN position in order to slow cab descent.

IMPORTANT: If the cab stops after it has gone beyond 45 degrees, don't force it down with the tilt pump. The velocity fuses have locked the tilt cylinders. To unlock them, see **Hydraulic Lockup**, below.

Returning the Cab to Operating Position

DANGER

Stay completely clear of the cab's travel path at all times. Once the safety stop has been released, don't lean over the frame rails, the engine, or the transmission for any reason. To do so could result in serious injury or death.

1. Move the pump lever to the RETURN position.

Vehicle Access

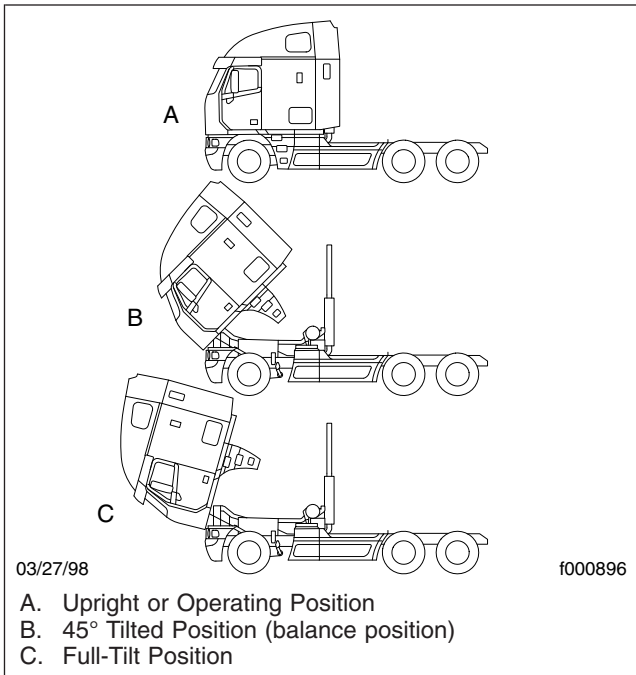

Fig. 2.15, Cab Tilt Positions

2. Check the cab travel path for obstructions.
3. Press and hold the button on the pump to begin moving the cab to the operating position.

NOTE: To slow the cab descent, reverse the tilt pump lever after the cab passes the balance point.

4. Allow the cab to lower to the safety stop, then move the safety stop away from the right tilt cylinder rod. See **Fig. 2.16**.
5. Press and hold the button on the pump until the cab nears a 45-degree angle (the balance point). See **Fig. 2.15**. Once the cab goes beyond 45 degrees, release the button on the pump and move the tilt pump lever to the TILT position in order to slow cab descent.

IMPORTANT: If the cab stops after it has gone beyond 45 degrees, don't force it down with the tilt pump. The safety stop is in the locked position or, the velocity fuses have locked the tilt cylinders. Release the safety stop or, to unlock the fuses, see **Hydraulic Lockup**, below.

6. Move the pump lever to the RETURN position.

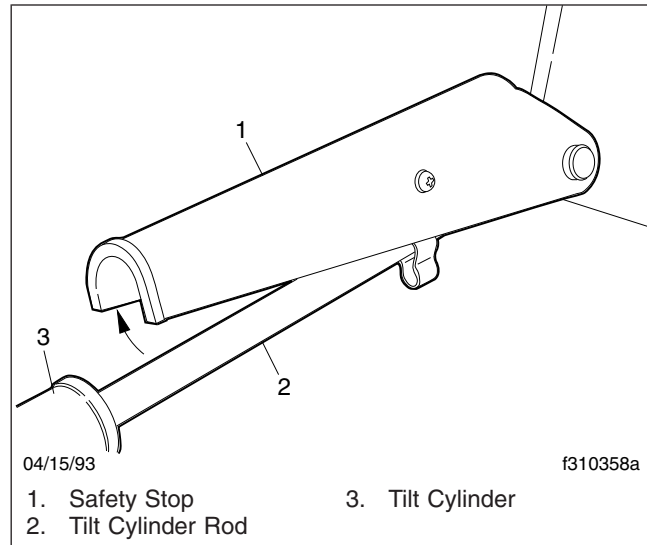

Fig. 2.16, Safety Stop Disengaged

7. Check the indicator pin on each cab latch. The latches are locked when the pins have moved back into the piston and cylinder spring assembly.

NOTE: Maintain the hydraulic oil level at the oil fill plug. Add oil only when the cab is in the operating position. Use only Freightliner-approved hydraulic oil. See **Group 60** of the *Century Class Trucks Maintenance Manual*.

8. Close the grille.
9. Switch off the tilt system dash switch.

Hydraulic Lockup

Hydraulic lockup can occur for the following reasons:

- very cold temperatures
- use of the wrong hydraulic fluid
- air in the system
- sudden cab movement
- ruptured hydraulic line
- continued pumping after the cab goes over-center
- tilt strut in locked position while lowering the cab

Any of the above situations will lock the tilt cylinders. To unlock the cylinders, the cab must be moved in the opposite direction of travel.

For example, if the cab is moving toward the full-tilt position when the lockup occurs, move the control lever to RETURN and work the pump a few strokes to unlock the cylinders. Move the control lever to the TILT position and allow the cab to descend to a full-tilt position.

If the cab is moving toward the lowered (operating) position when the lockup occurs, move the control lever to TILT and work the pump a few strokes to unlock the cylinders. Move the control lever to RETURN and allow the cab to descend to the operating position.

3

Electrical System

Circuit Breaker/Relay Panel	3.1
Low Voltage Disconnect Feature	3.1
Cab Load Disconnect Switch	3.1
Battery Access	3.1

Electrical System

Circuit Breaker/Relay Panel

The circuit breaker/relay panel is located in the dash in front of the passenger seat. To access the compartment, press the button labeled PRESS and lift the top dash panel. See [Fig. 3.1](#).

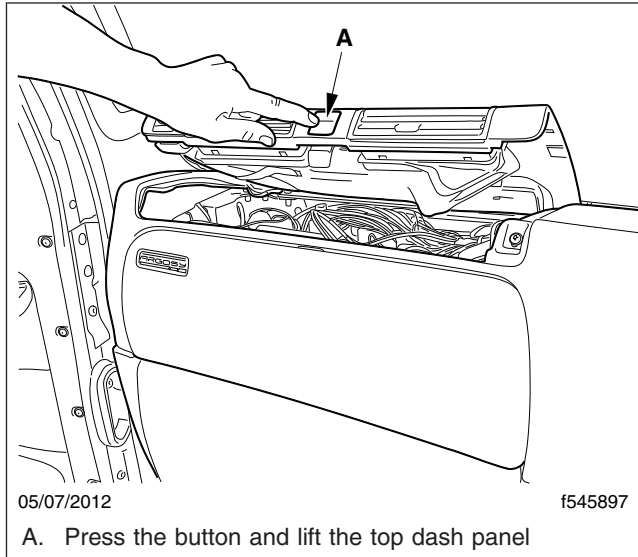

Fig. 3.1, Circuit Breaker/Relay Panel (right-hand drive shown)

Low Voltage Disconnect Feature

The low voltage disconnect (LVD) feature protects the batteries from excessive discharge by disconnecting certain circuits from battery power supply. This allows the batteries to maintain acceptable charge to restart the vehicle. The LVD system turns off cab and sleeper accessories when voltage drops to 12.3 volts. An alarm sounds for one minute before accessories are turned off. If no action is taken within that minute, the LVD module will shut off power to predetermined cab and sleeper circuits and illuminate an LED indicator on the LVD module located inside the right-hand door frame behind the seat. These circuits will remain off until the LVD measures 13.0 volts on the electrical system, which can be done by starting the engine. After the engine is started, the system will reset.

All vehicles equipped with LVD should have a sticker on the dash indicating the presence of the system.

Another sticker is located inside the right-hand door frame behind the seat, along with the LVD module.

Cab Load Disconnect Switch



Turning the cab load disconnect switch (CLDS) to the off position does not disconnect the connection between the battery and the starter. To work on the vehicle safely, the negative leads must be disconnected from the battery.

IMPORTANT: The ignition should be turned off before turning the CLDS to on or off.

The CLDS is used to avoid excessive draw on the battery when the vehicle is parked for an extended period of time by disconnecting (or opening) the connection between the battery and the most of the vehicle electrical system. See [Fig. 3.2](#).

The CLDS may be mounted:

- inside the cab on the outboard side of the driver's seat;
- at the battery box;
- outboard on the left frame rail.

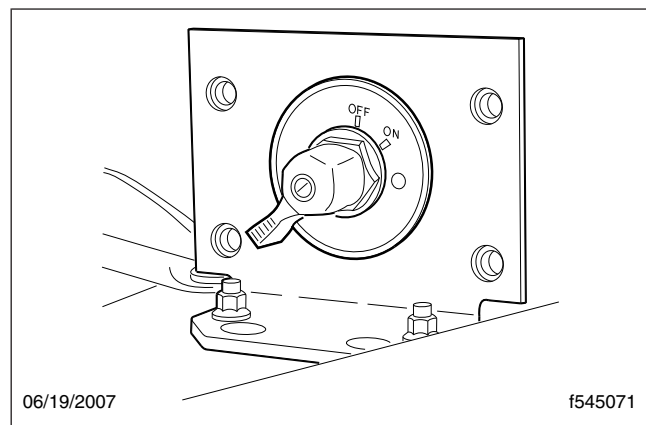

Fig. 3.2, Cab Load Disconnect Switch

Battery Access

NOTE: On vehicles with vertically-mounted mufflers, tilt the cab slightly to open the battery box.

The batteries are typically located aft wall of the cab/sleeper compartment. To remove the cover from the battery box, release the latch and lift the cover.

4

Instruments

Instrumentation Control Units	4.1
Warning and Indicator Lights	4.3
Instruments	4.7
Driver Message Center	4.10
Overhead Instrument Panel	4.19

Instruments

Instrumentation Control Units

The instrumentation control unit (ICU) provides the driver with engine and vehicle information. It is comprised of standard and optional gauges, an audible warning, a driver message center, and a lightbar containing warning and indicator lamps (also known as telltales). Warning and indicator lamps illuminate in red (danger), amber (caution), green (status advisory), or blue (high-beam headlights activated).

Argosy vehicles are equipped with either an ICU4M (Fig. 4.1), ICU3 (Fig. 4.2), or ICU2M (Fig. 4.3).

The following headings in this chapter provide additional information and operating instructions for ICU components:

- "Warning and Indicator Lights"
- "Instruments"
- "Driver Message Center"

Ignition Sequence

When the ignition is turned on, the ICU runs a self-check. See Fig. 4.4. Observing the ignition sequence is a good way to ensure the ICU is functioning properly.

IMPORTANT: Do not crank the engine until the ICU gauge sweep is complete.

NOTE: Air gauges do not complete a sweep of their dials during the ignition sequence.

When the ignition is turned on, the following actions should occur:

- electronic gauges complete a full sweep of their dials
- some warning and indicator lamps illuminate, then are extinguished

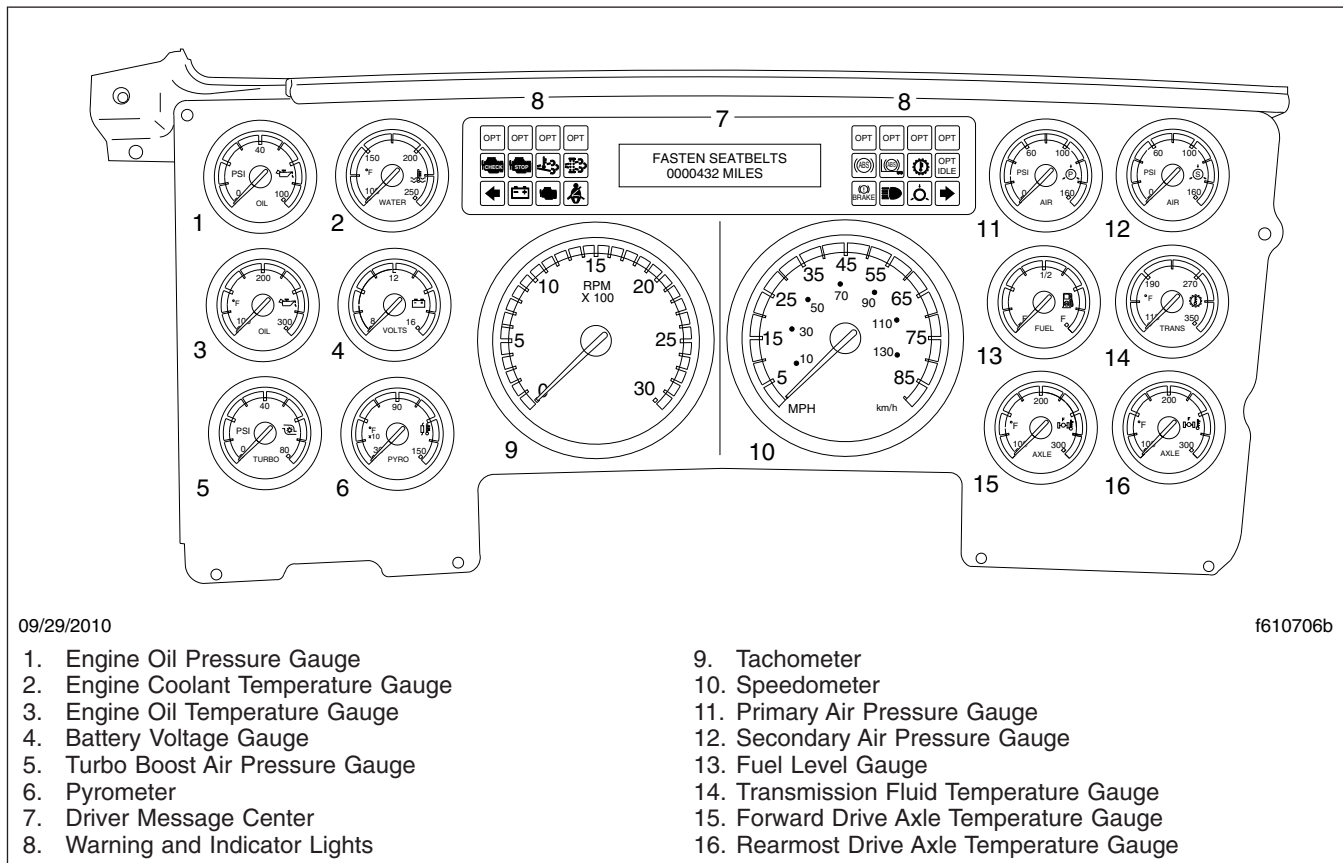

Fig. 4.1, ICU4M Instrument Cluster (typical)

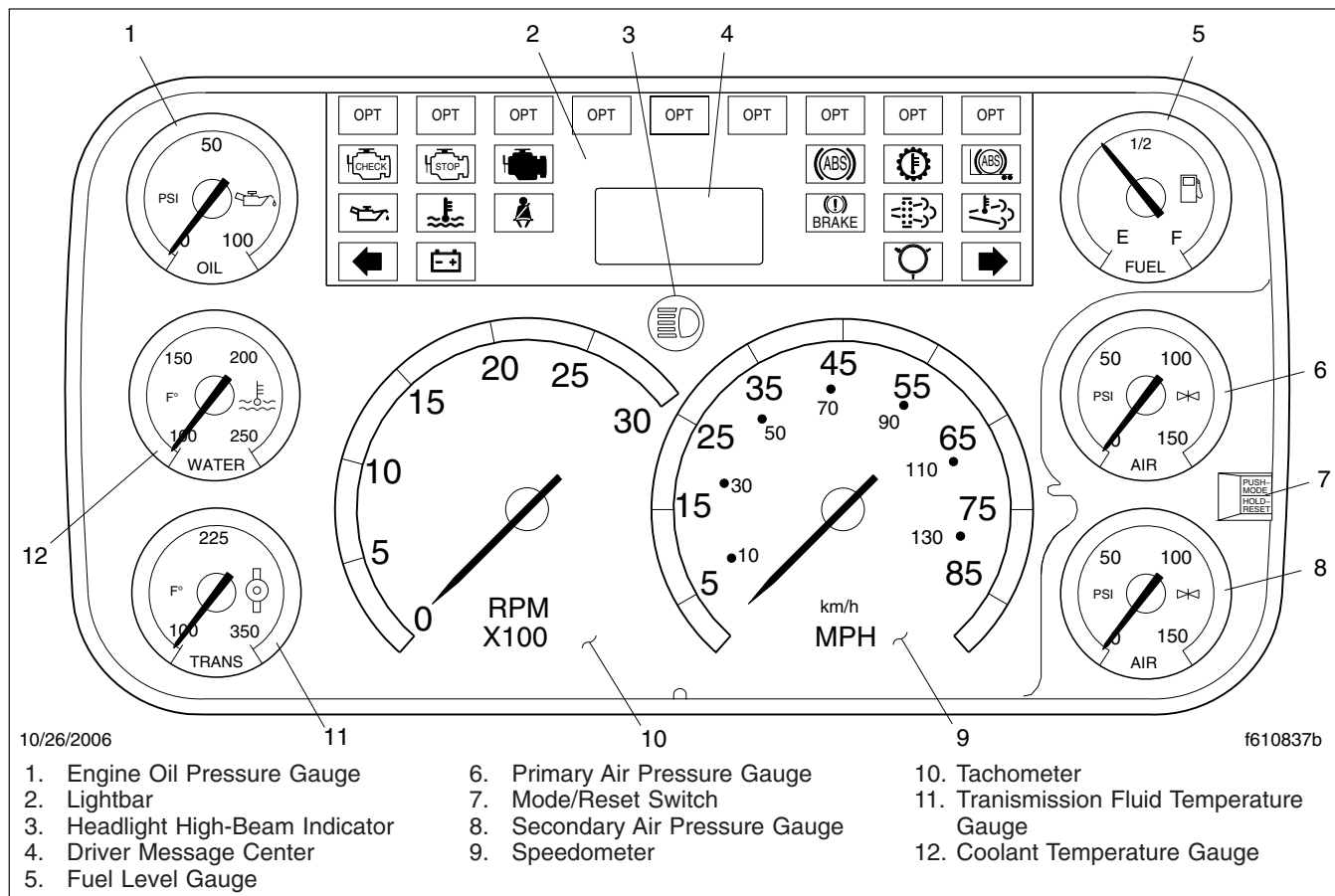

Fig. 4.2, ICU3 Instrument Cluster

- audible alert sounds until sufficient air pressure builds up in the primary and secondary air systems
- software revision level of the ICU is displayed on the driver message center, followed by any active faults

IMPORTANT: If any red or amber warning or indicator lamps do not illuminate during the ICU self-check or do not extinguish after the self-check completes, take the action outlined in [Table 4.1](#), or take the vehicle to an authorized Daimler Trucks service facility as soon as possible.

NOTE: If active faults are present, take the vehicle to an authorized Daimler Trucks service facility as soon as possible.

If the ICU receives active fault codes, it displays them one after the other until the parking brake is released or the ignition is turned off. Once the parking brake is completely released, the ICU displays the odometer. If there are no active faults, the ICU displays the odometer after the self-check completes.

When the self-check is complete on an ICU4M, the fasten seat belt screen displays if the engine is off. If the engine is running, the idle hours screen displays.

Audible Alerts

An audible alert sounds during the ignition sequence and whenever one of the following conditions exists:

- Engine oil pressure falls below the minimum preset value.
- Coolant temperature rises above the maximum preset value.

Instruments

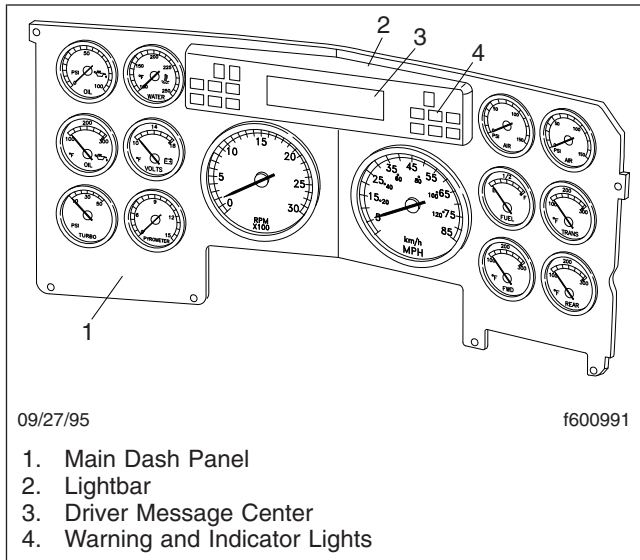

Fig. 4.3, ICU2M Instrument Cluster (typical)

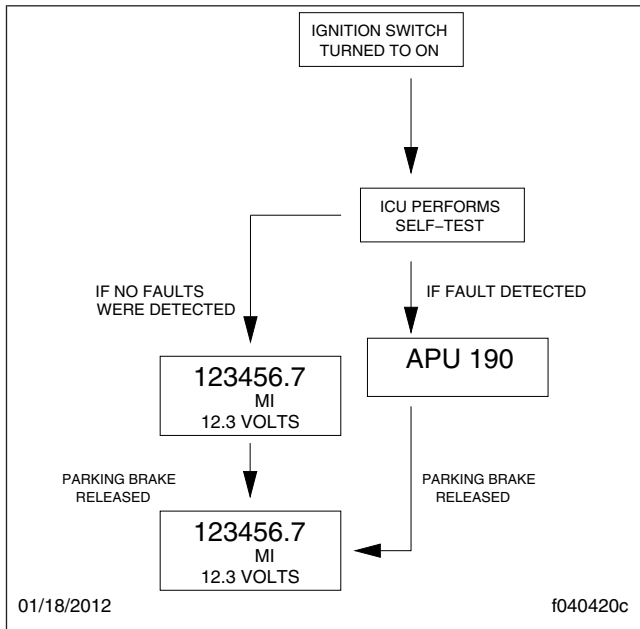

Fig. 4.4, ICU Self-Check

- Air pressure falls below approximately 70 psi (483 kPa).
- Parking brake is set with the vehicle moving faster than two miles per hour.
- System voltage falls below 12 volts.

- Door is open or the headlights are on, with the parking brake off.

Warning and Indicator Lights

The ICU lightbar has three or four rows of warning and indicator lights with icon symbols, depending on the ICU. The positions of the lights may vary for the different ICU's, but the telltales are standard for all applications. See [Table 4.1](#) for a listing of standard and commonly used warning and indicator lamps.

Warning and indicator lamps illuminate in red (danger), amber (caution), green (status advisory), or blue (high-beam headlights active).

IMPORTANT: Depending upon local jurisdictional emissions guidelines, vehicles may not be equipped with all of the lamps shown in [Table 4.1](#).

Engine Protection System











When the red STOP engine lamp illuminates, most engines are programmed to shut down automatically within 30 seconds. The driver must immediately move the vehicle to a safe location at the side of the road to prevent causing a hazardous situation that could cause bodily injury, property damage, or severe damage to the engine.













See [Fig. 4.5](#) for an explanation of the aftertreatment system (ATS) warning indicators, and actions required to avoid further engine protection steps.



The STOP engine lamp illuminates when the engine protection system is activated in one of two ways. On some engines, the engine protection system will derate the engine, allowing it to run at lower rpm and slower vehicle speed. Drive the vehicle to a safe location or to a service facility.

IMPORTANT: Safely bring the vehicle to a stop on the side of the road and shut down the engine as soon as the red light is seen. If the engine shuts down while the vehicle is in a hazardous location, turn the key to the OFF position for a few seconds, then restart the engine and move the vehicle to a safer location.

Common Warning and Indicator Lamps			
	Lamp Description	Color	
	STOP Engine*	Red	
	Indicates a serious fault that requires engine shutdown immediately. The engine protection system will reduce the maximum engine torque and speed, and, if the condition does not improve, will shut down the engine within 30 to 60 seconds. Safely bring the vehicle to a stop on the side of the road and shut down the engine as soon as the red light is seen. IMPORTANT: If the engine shuts down while the vehicle is in a hazardous location, turn the key to the OFF position for a few seconds, then restart the engine and move the vehicle to a safer location.		
	High Coolant Temperature		Indicates the coolant temperature is above the maximum allowable temperature.
	Low Air Pressure		Indicates air pressure in the primary or secondary reservoir is below 70 psi (483 kPa).
	Low Engine Oil Pressure		Indicates the engine oil pressure is below the minimum allowable pressure.
	Parking Brake		Indicates the parking brake is engaged. An audible alert activates when the vehicle is moving over 2 mph (3 km/h) with the parking brake set.
	Low Battery Voltage		Indicates that battery voltage is 11.9 volts or less.
	Unfastened Seat Belt	Activates with an audible alert when the system detects that the parking brake is off and the driver seat belt is not fastened on some vehicles. On other vehicles, this lamp illuminates for 15 seconds when the ignition is first turned on.	
	CHECK Engine*	Amber	
	Indicates an engine condition (low oil pressure, low coolant level, high coolant temperature, high DPF soot level, or uncontrolled DPF regeneration) that requires correction. Correct the condition as soon as possible. If the condition worsens, the STOP engine lamp will illuminate.		
	High Exhaust System Temperature (HEST)*	Slow (10-second) flashing indicates a regeneration (regen) is in progress. IMPORTANT: When the HEST lamp is illuminated, do not park the vehicle near flammable material. Solid illumination indicates high exhaust temperatures at the outlet of the tail pipe when speed is below 5 mph (8 km/h).	





Instruments

Common Warning and Indicator Lamps			
Lamp Description			Color
	Diesel Particulate Filter (DPF) Status	<p>Solid illumination indicates a regen is required. Change to a more challenging duty cycle (such as highway driving) to raise exhaust temperatures for at least twenty minutes, or perform a parked regen.</p> <p>Blinking indicates that a parked regen is required immediately. An engine derate and shutdown will occur.</p>	Amber
	Malfunction Indicator Lamp (MIL)	Indicates an emissions-related fault. See the engine operation manual for details.	
	Vehicle ABS	<p>Momentary illumination indicates the vehicle ABS is engaged.</p> <p>Solid illumination indicates a problem with the vehicle ABS. Repair the ABS immediately to ensure full braking capability.</p>	
	Trailer ABS	<p>Momentary illumination indicates the trailer ABS is engaged.</p> <p>Solid illumination indicates a problem with the trailer ABS. Repair the ABS immediately to ensure full braking capability.</p>	
	No Charge	Indicates the alternator is not properly powering the electrical system.	
	Water in Fuel	Indicates the fuel may contain water. Drain any water collected in the fuel/water separators.	
	Fuel Filter Restriction	Indicates the fuel filter is clogged and requires service.	
	Check Transmission	Indicates an undesirable transmission condition.	
	Transmission Overheat	Indicates high transmission temperature.	
	Wheel Spin	<p>Flashing indicates the ATC system is active, or the ATC button has been pressed to allow wheel slip.</p> <p>Solid illumination indicates a problem with the ATC system. Repair the ATC system immediately to ensure full braking capability.</p>	
	Engine Brake	Indicates the engine brake is enabled.	Green
	Left-Turn Signal	Flashing indicates the outside left-turn signal lights are activated.	

Common Warning and Indicator Lamps		
Lamp Description		Color
	Right-Turn Signal Flashing indicates the outside right-turn signal lights are activated.	Green
	High-Beam Headlights Indicates the high-beam headlights are on.	Blue

* See Fig. 4.5 for an explanation of the aftertreatment system (ATS) warning indicators, and actions required to avoid further engine protection steps.

Table 4.1, Common Warning and Indicator Lamps

EXHAUST AFTERTREATMENT SYSTEM INFORMATION					
INDICATOR LAMP(S)	 (Solid) Level 1	 (Flashing) Level 2	 (Flashing) Level 3	 Level 4	 WARNING
Indicator Lamp Message(s)	Filter Regeneration Recommended.	Filter Regeneration Necessary	Parked Regeneration Required – Engine Derate	Service Regeneration Required. Engine Derate To Idle Only.	HEST (High Exhaust System Temperature)
Diesel Particulate Filter Condition	Filter is reaching capacity.	Filter is now reaching maximum capacity.	Filter has reached maximum capacity.	Filter has exceeded maximum capacity.	Flashing A regeneration is in progress.
Required Action	Bring vehicle to highway speeds to allow for an Automatic Regeneration or perform a Parked Regeneration.	To avoid engine derate, bring vehicle to highway speeds to allow for an Automatic Regeneration, or perform a Parked Regeneration as soon as possible.	Vehicle must be parked, and a Parked Regeneration must be performed. Engine will begin derate.	Vehicle must be parked, and a Service Regeneration must be performed. Check engine operator's manual for details. Engine will shut down.	Solid Exhaust components and exhaust gas are at high temperature. When stationary, keep away from people and flammable materials or vapors.
For a driver performed Parked Regeneration, vehicle must be equipped with a dash mounted Regeneration Switch.					

02/20/2009

f080156

Fig. 4.5, ATS Warning Lamps

On other engines, the engine protection system will shut down the engine. It will first derate the engine, then shut it down completely 30 to 60 seconds after the indicator illuminates (depending on the critical fault type) if the condition does not improve. Bring the vehicle to a stop on the side of the road before the engine shuts down.

Some vehicles may have a shutdown-override switch, which may be used to momentarily override the shutdown sequence. See [Chapter 10](#) for detailed information regarding the shutdown process.

IMPORTANT: Do not attempt to restart the engine while the vehicle is moving. Bring the vehicle to a safe stop, then restart the engine.

To restart the engine, turn the ignition switch to OFF for a few seconds, then turn the ignition switch to ON and let the gauge sweep complete before starting the engine. The engine will run for a short period and shut down again if the condition does not improve.

Instruments

Instruments

Standard instruments are present on every vehicle. Optional instruments, typically located on the auxiliary dash panel or right-hand control panel, are not found on every vehicle. Instruments are listed here in alphabetical order to make the information easier to find.

Air Intake Restriction Gauge

The air intake restriction gauge indicates the vacuum on the engine side of the air cleaner. On standard installations, it is mounted on the air cleaner. As an option for easier viewing, an air intake restriction indicator (see Fig. 4.6) can be mounted on the auxiliary dash panel.

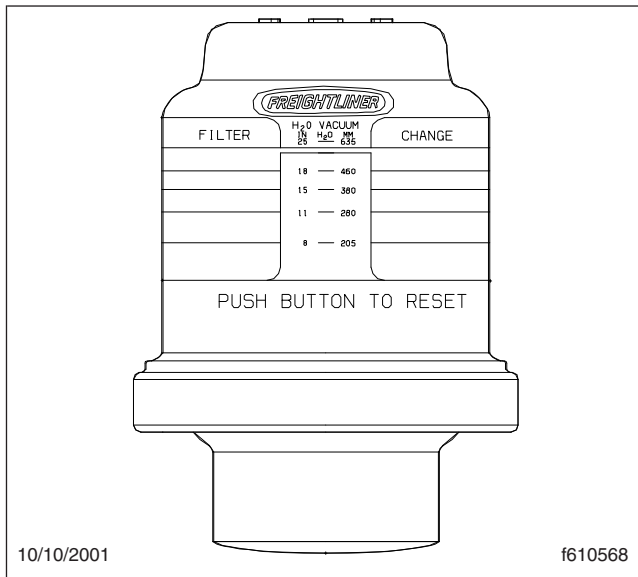

Fig. 4.6, Air Intake Restriction Indicator

NOTE: Rain or snow can wet the filter and cause a temporary high reading.

Air intake restriction vacuum is measured in inches of water (inH₂O). For vehicles equipped with a graduated indicator or a restriction gauge on the dash, check the gauge with the engine off. If the yellow signal stays locked in the red zone once the engine is shut down, or is at or above the values shown in Table 4.2, the air cleaner element needs to be replaced.

Vehicles may be equipped with a go/no-go restriction indicator without graduations (see Fig. 4.7) instead of a graduated indicator.

Air Intake Maximum Restriction Values (inH ₂ O)		
Engine Make	Pre-EPA07 (ADR 80/02) Engines	EPA07 (ADR 80/03) Engines
Cummins	25	25
Detroit	20	22
Mercedes-Benz	22	22

Table 4.2, Air Intake Maximum Restriction Values

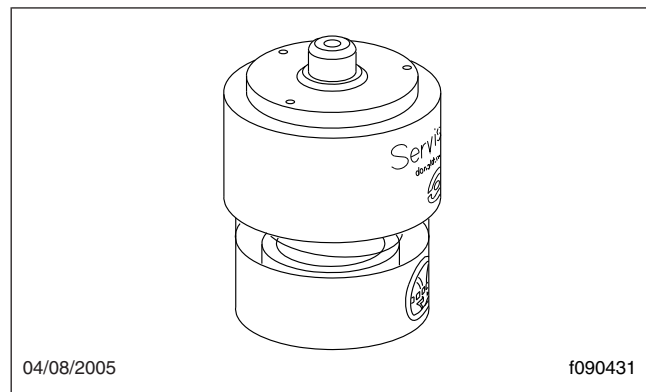

Fig. 4.7, Manual-Reset Air Restriction Indicator, Go/No-Go

If air restriction exceeds the maximum allowable value, operate the vehicle for one more day, making sure not to run the engine over rated rpm. Refer to the engine operation manual for more information on rated rpm for your engine.

If air restriction exceeds the maximum value again, replace the air cleaner. For instructions, refer to **Group 09** of the *Century Class Trucks Workshop Manual*.

Application Air Pressure Gauge

An application air pressure gauge registers the air pressure being used to apply the brakes, and should be used for reference only. The gauge will not register air pressure until the foot brake pedal is depressed or the trailer hand brake is applied.

Coolant Temperature Gauge

NOTICE

A sudden increase in coolant temperature may indicate engine or cooling system failure. Bring the vehicle to a safe stop and investigate the cause to prevent further damage. Do not operate the engine until the cause has been determined and corrected.

During normal engine operation, the coolant temperature gauge should read 175 to 195°F (79 to 91°C). If the temperature remains below 160°F (71°C), inspect the cooling system to determine the cause.

If coolant temperature rises above the maximum temperature listed in [Table 4.3](#), the CHECK engine lamp will illuminate. If the condition does not improve, the STOP engine lamp will also illuminate and an audible warning will sound. The engine will then derate or shut down, depending on the type of engine protection system installed.

Maximum Coolant Temperature	
Engine Make	Temperature: °F (°C)
Cummins	225 (107)
Detroit	215 (101)
Mercedes-Benz	221 (105)

Table 4.3, Maximum Coolant Temperature

Drive Axle Oil Temperature Gauges

NOTICE

A sudden increase in oil temperature that is not caused by a load increase may indicate mechanical failure. Bring the vehicle to a safe stop and investigate the cause to prevent further damage. Do not operate the vehicle until the cause has been determined and corrected.

During normal operation, drive axle oil temperature gauges should read as follows:

- 160 to 220°F (71 to 104°C) for Detroit™ and Meritor™ drive axles
- 180 to 200°F (82 to 93°C) for Dana Spicer® drive axles

Under heavy loads, such as when climbing steep grades, temperatures that exceed the normal oil temperature range for a short period are not unusual. If the temperature returns to normal when the load decreases, there is no problem.

Engine Oil Pressure Gauge

NOTICE

A sudden decrease or absence of oil pressure may indicate mechanical failure. Bring the vehicle to a safe stop and investigate the cause to prevent further damage. Do not operate the engine until the cause has been determined and corrected.

The engine oil pressure gauge displays the current engine oil pressure. If engine oil pressure falls below the minimum levels shown in [Table 4.4](#), the CHECK engine lamp will illuminate. If the condition does not improve, the STOP engine lamp will also illuminate and an audible warning will sound. The engine will then derate or shut down, depending on the type of engine protection system installed.

Minimum Oil Pressure*		
Engine Model	At Idle Speed: psi (kPa)	At Rated RPM: psi (kPa)
Cummins	15 (103)	35 (241)
Detroit	14 (97)	55 (350)
Mercedes-Benz	7 (50)	36 (250)

* Oil pressures are given with the engine at operating temperature. With the engine cold, oil pressure may be higher. Individual engines may vary from the listed pressures; observe and record pressures when the engine is new to create a guide for checking engine condition.

Table 4.4, Minimum Engine Oil Pressure

Engine Oil Temperature Gauge

NOTICE

A sudden increase in oil temperature that is not caused by a load increase may indicate mechanical failure. Bring the vehicle to a safe stop and investigate the cause to prevent further damage. Do not operate the engine until the cause has been determined and corrected.

During normal operation, the optional engine oil temperature gauge should read:

Instruments

- 200 to 260°F (93 to 126°C) for Detroit and Cummins engines
- 177 to 203°F (81 to 95°C) for Mercedes-Benz engines

Under heavy loads, such as when climbing steep grades, temperatures that exceed the normal oil temperature range for a short period are not unusual. If the temperature returns to normal when the load decreases, there is no problem.

Fuel Gauge

The fuel gauge indicates the level of fuel in the fuel tank(s). A single fuel gauge is standard. If equipped with an optional second fuel tank, each fuel tank level is indicated on a separate gauge.

Primary and Secondary Air Pressure Gauges



If air pressure falls below minimum pressure, the braking ability of the vehicle will be limited. Slow the vehicle down and bring it to a gradual stop. Do not attempt to move the vehicle until air pressure has risen above the minimum level. Moving a vehicle without adequate braking power could cause an accident resulting in property damage, personal injury, or death.

Air pressure gauges register the pressure in the primary and secondary air systems. Normal pressure, with the engine running, is 100 to 120 psi (689 to 827 kPa) in both systems.

A low-air-pressure warning light and audible alert, connected to both the primary and secondary systems, activate when air pressure in either system drops below 64 to 76 psi (441 to 524 kPa).

When the engine is started, the warning light and audible warning remain on until air pressure in both systems exceeds minimum pressure.

Speedometer

Two speedometer options are available. The U.S. version of the speedometer registers speed in both miles per hour (mph) and kilometers per hour (km/h), with mph in larger numbers. The metric version of the speedometer face reverses this arrangement, with km/h in larger numbers.

Tachometer

The tachometer indicates engine speed in revolutions per minute (rpm) and serves as a guide for shifting the transmission and keeping the engine in the appropriate rpm range. For low idle and rated rpm, see the engine identification plate.

Transmission Fluid Temperature Gauge

The transmission fluid temperature gauge indicates the transmission lubricant operating temperature. Temperatures vary by application, but the transmission fluid temperature gauge reading should not exceed 250°F (121°C).

NOTICE

A sudden increase in transmission fluid temperature that is not caused by a load increase may indicate mechanical failure. Bring the vehicle to a safe stop and investigate the cause to prevent further damage. Do not operate the vehicle until the cause has been determined and corrected.

Under heavy loads, such as when climbing steep grades, temperatures that exceed the normal oil temperature range for a short period are not unusual. If the temperature returns to normal when the load decreases, there is no problem.

Turbocharger Boost Pressure Gauge

A turbocharger boost pressure gauge indicates the pressure in the intake manifold, in excess of atmospheric pressure, being created by the turbocharger.

Voltmeter

The voltmeter indicates the vehicle charging system voltage when the engine is running and the battery voltage when the engine is off. By monitoring the voltmeter, the driver can stay aware of potential battery charging problems and have them fixed before the batteries discharge enough to create starting difficulties. Argosy vehicles are equipped with either a voltmeter gauge, or a digital voltmeter readout located on the bottom line of the dash message center.

The voltmeter will normally show approximately 13.7 to 14.1 volts when the engine is running. The voltage of a fully charged battery is 12.7 to 12.8 volts when the engine is off. Battery voltage under 12.0 volts is

considered a low battery, and a completely discharged battery will produce only about 11.0 volts.

If the voltmeter shows an undercharged or overcharged condition for an extended period, have the charging system and batteries checked at an authorized Freightliner service facility.

On a vehicle equipped with a battery isolator system, the voltmeter measures the average voltage of all the batteries when the engine is running. When the engine is off, the voltmeter shows only the isolated battery voltage and does not indicate the voltage of the engine-starting batteries.

Driver Message Center

The dash message centers for the following instrument clusters are described below:

- ICU4M
- ICU3
- ICU2M

ICU4M

Functions

A keypad located on the auxiliary dash panel controls the driver message center. See [Fig. 4.8](#).

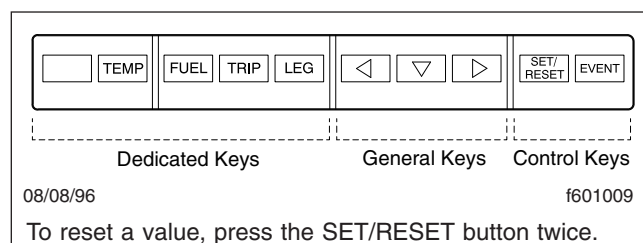

Fig. 4.8, ICU4M/ICU2M Keypad

Main features of the ICU4M include:

- Gauges that sweep 270 degrees and have pointers lit by an LED.
- Service intervals that are programmable via two dash-mounted switches.
- An audible warning and alert message to warn the driver if the door is opened without first setting the parking brake.

- A flashing alert message that appears on the driver message center in low engine oil pressure or high coolant temperature conditions.

With the parking brake off, only the odometer and alert screens will display. Park the vehicle and set the parking brake to access additional screens.

The dash message center displays alert screens when certain conditions occur. They are warnings, cautions, or other messages that require the driver's attention, but not all of them are critical to the operation of the vehicle. Warning messages always display at full brightness.

More important messages take priority over less important messages. The order of priority is:

1. parking brake set (with the vehicle moving)
2. parking brake off (with the door open)
3. low oil pressure or high coolant temperature
4. hard brake warnings (if equipped with roll stability advisor)
5. low battery voltage
6. turn signal on
7. service warnings
8. no datalink activity

Alert Screens

NOTE: If there is more than one alert message to display, tap any key to access the next message, and so on, until all the messages have been viewed.

Parking Brake On

This warning message and an audible warning come on whenever the parking brake is applied and the vehicle is moving faster than 2 mph (3 km/h). The screen and audible warning go away only when the parking brake is released, or speed is reduced below 2 mph.

Low Oil Pressure

This warning message and an audible warning come on whenever the oil pressure falls below the minimum oil pressure, whether the vehicle is idling or in motion. Tap any key to dismiss the message.

Instruments

If the fault is still active 30 seconds after the message is dismissed, the warning message will come on again.

High Coolant Temp

This message and an audible warning come on whenever the engine coolant temperature exceeds the maximum allowable temperature.

If the fault is still active 30 seconds after the message is dismissed, the warning message will come on again.

Low Voltage

On some vehicles, this optional message and an audible warning come on whenever the ICU detects a low voltage condition.

Turn Signal On

This warning message and audible warning come on whenever the turn signal remains on for four minutes or five miles of travel.

To dismiss this message, either turn off the turn signal or tap any key.

Service Warnings

Service warning screens display during the ignition sequence and indicate that a service interval has been reached or exceeded and maintenance is required. The messages may indicate the number of miles (KM) or hours until the next required service or, once passed, the number of miles (KM) or hours ago that maintenance should have been performed.

Automated Transmission Display

The ICU4M can display current gear information for vehicles with an automated transmission. The last three digits at the far right on the lower line of the driver display screen are reserved for this information.

If there is a request to shift, an up or down arrow is also displayed, depending on the shift direction.

On vehicles with conventional manual or automatic transmissions, the gear and shift direction are not displayed. For more information about specific models of automated transmissions, see [Chapter 8](#).

Mobile Screens

The following screens are available when the parking brake is off (when the vehicle is mobile).

- i. Fasten seat belt (rpm<100)
- ii. Fuel economy (rpm>100)
- iii. Odometer
- iv. Trip distance/hours
- v. Trip advisory
- vi. Leg distance/hours
- vii. Leg advisory
- viii. Outside air temperature
- ix. Fuel used/average MPG (KM/L)

Stationary Screens

NOTE: Metric unit screens are similar. AMT= Current gear information for automated manual transmissions.

The following screens are available when the parking brake is on (when the vehicle is stationary).

- i. Odometer
- ii. Trip information including trip miles/hours, idle hours, average speed, leg miles/hours
- iii. Fuel information including fuel used, fuel economy, idle/PTO fuel usage
- iv. Engine information including engine miles/hours, engine/PTO gallons, oil level
- v. Diagnostic information
- vi. Service information including mileage or time to next service
- vii. Setup information
- viii. Vehicle information including Datalink status, ICU serial number, software version
- ix. Fasten seat belt warning

Trip Information

When idle hours are displayed, tap the any key to access the main trip information screen. See [Fig. 4.9](#). Tap the arrow keys on the 10-key keypad to advance through the screens. Press and hold the SET/RESET key to reset any of the screens.

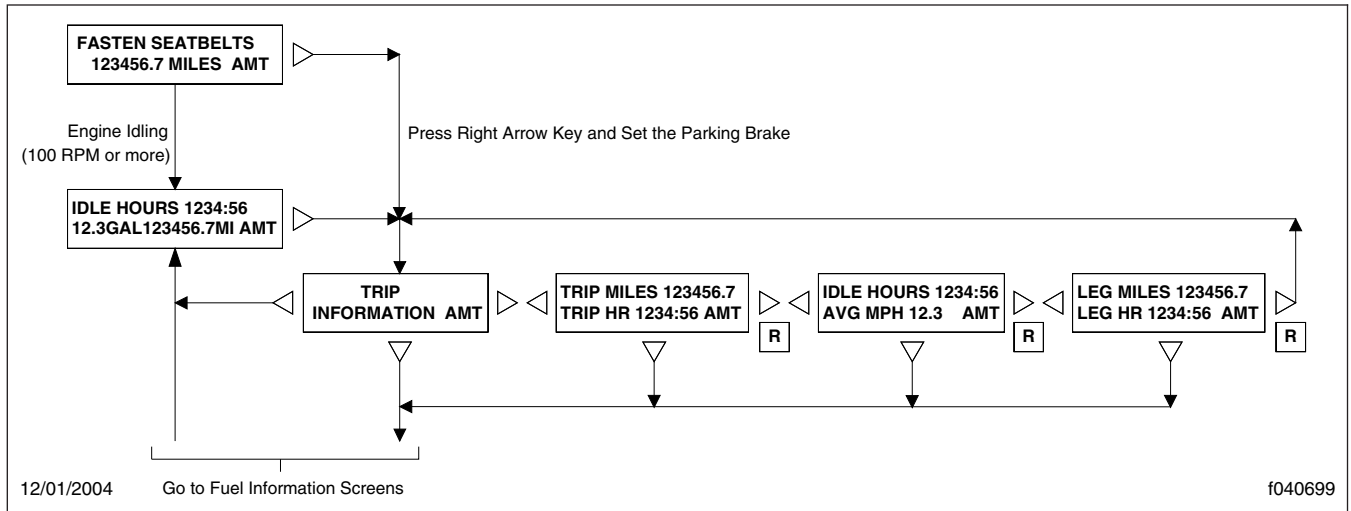

Fig. 4.9, ICU4M Trip Information Screens

Fuel Information

Fuel information allows you to view total fuel usage since the last reset, fuel mileage, and fuel consumed while idling or running the PTO. See [Fig. 4.10](#). Tap the arrow keys on the 10-key keypad to advance through the screens. Press and hold the SET/RESET key to reset any of the screens.

Engine Information

The engine information screens allow you to view engine mileage and hours, and total fuel consumption. See [Fig. 4.11](#). Tap the arrow keys on the 10-key keypad to advance through the screens.

Press and hold the SET/RESET key to reset any of the screens.

Diagnostic Information

If active fault codes are displayed on the diagnostic information screens, make a note of the fault code and text message, then take the vehicle to an authorized Freightliner service facility as soon as possible. See [Fig. 4.12](#) for a diagram of the diagnostic information screens.

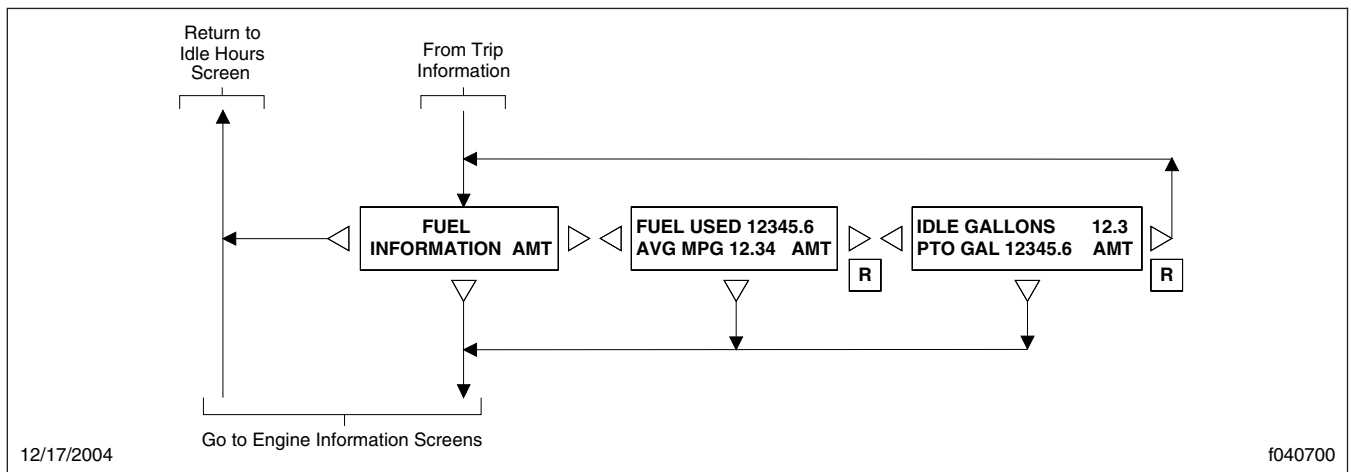

Fig. 4.10, ICU4M Fuel Information Screens

Instruments

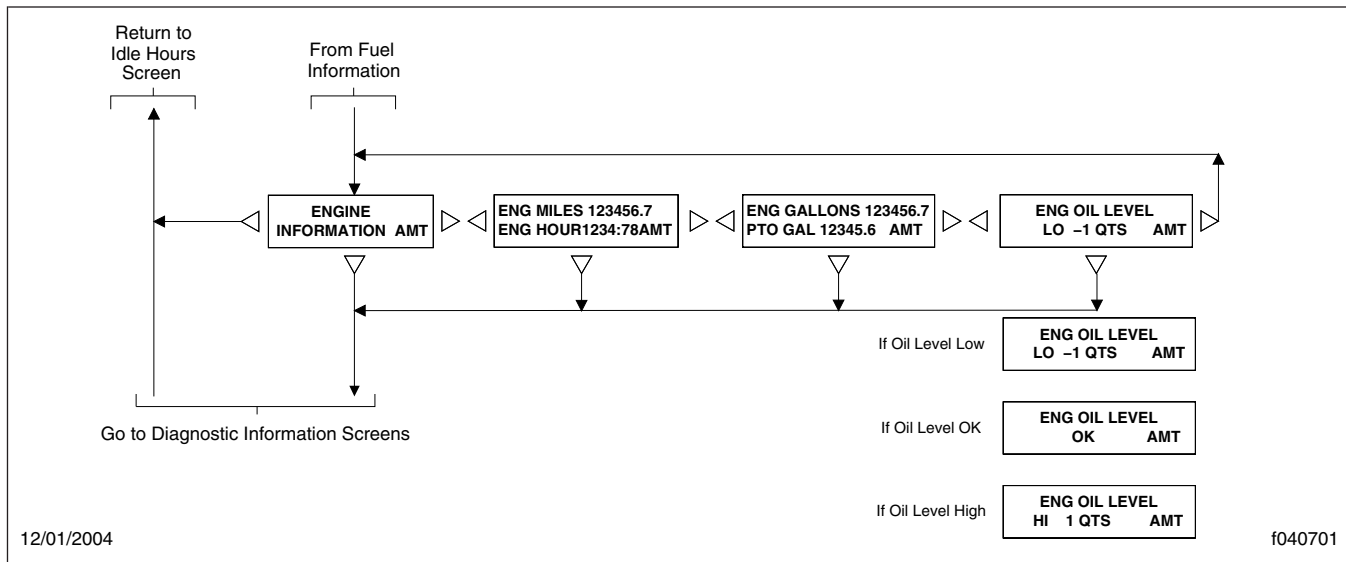

Fig. 4.11, ICU4M Engine Information Screens

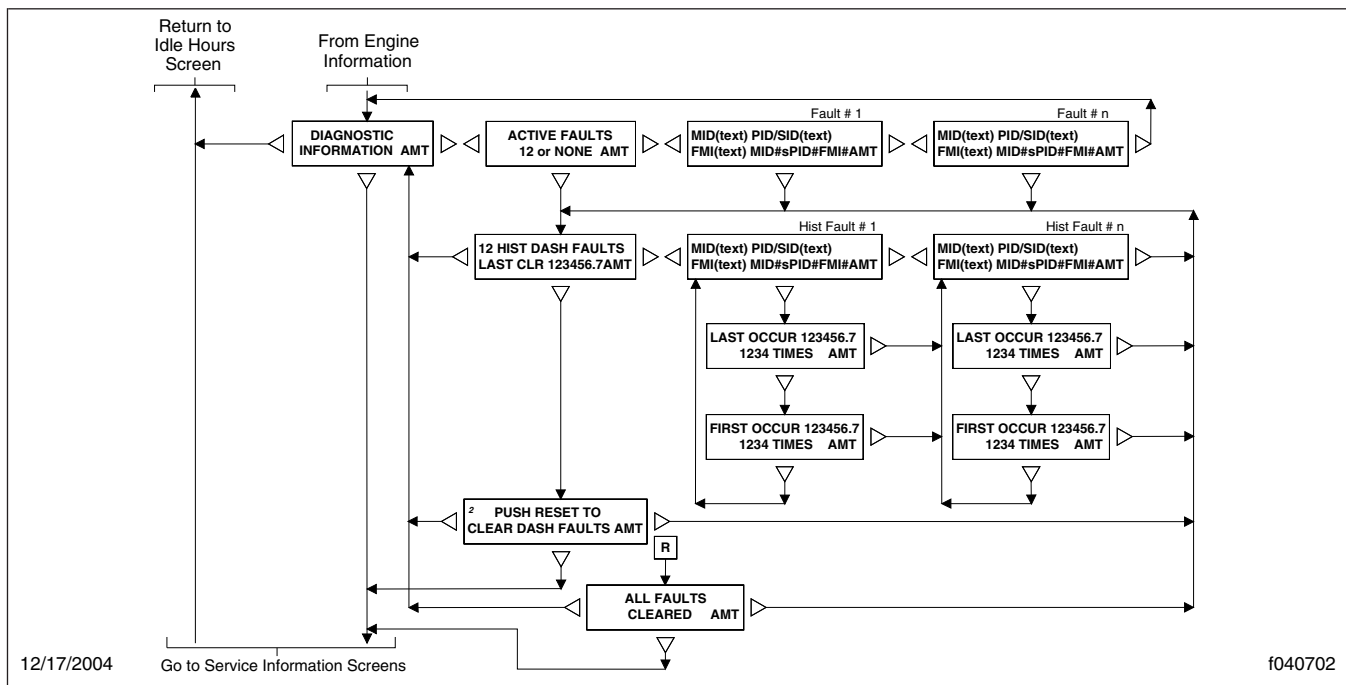

Fig. 4.12, ICU4M Diagnostic Information Screens

Service Information

Service information allows you to view the next recurring service interval, expressed in either miles or hours. See Fig. 4.13. Service intervals can also be deactivated, so they do not display at all.

For programming service intervals, see **Setup Information**, below.

NOTE: If the vehicle has gone past the service interval, the **miles (km)/hours remaining** screen is replaced by the **service was due**

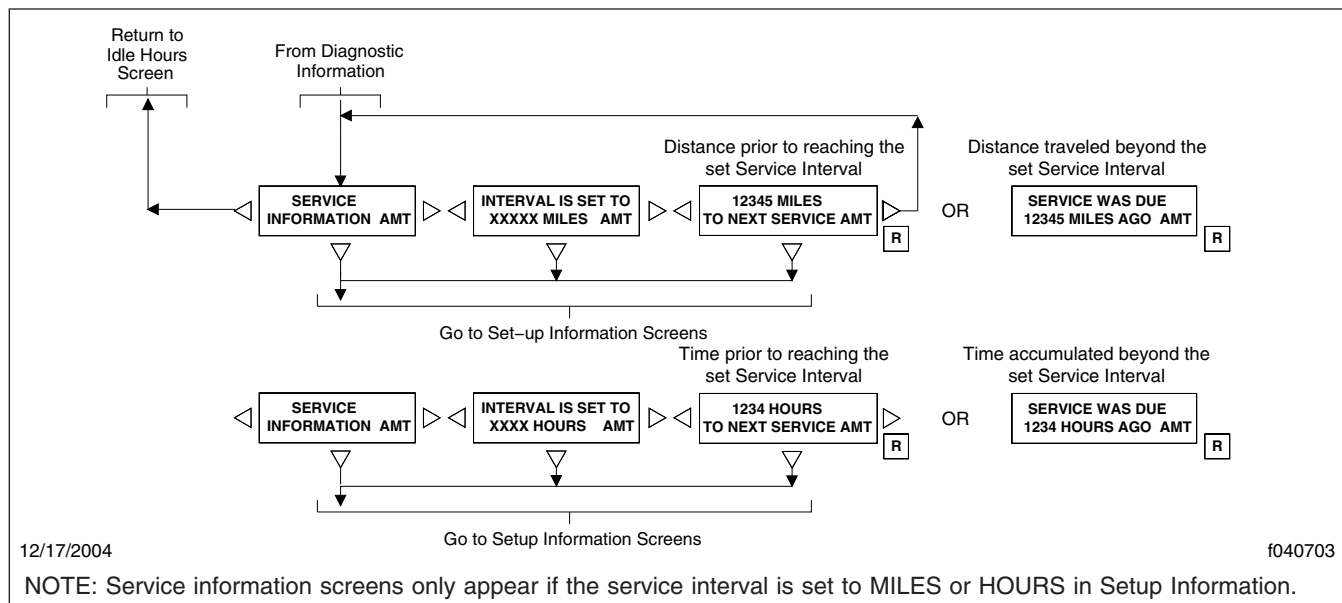

Fig. 4.13, ICU4M Service Information Screens

screen, followed by the number of miles(km)/ hours since the service was due.

Setup Information

See [Fig. 4.14](#) and [Fig. 4.15](#) for diagrams of the setup information screens.

Setup information allows you to program various features of the ICU4M environment, including:

- A. Service intervals (OFF/MILES/HOURS);
- B. Target MPG;
- C. LCD Lamp (ON/OFF);
- D. Driver message center brightness;
- E. Language (English/French/Spanish);
- F. Units of measurement (English/Metric);
- G. Driver select (ON/OFF)
- H. Reset parameters to original settings.

Vehicle Information Screens

The vehicle information screens display hardware and software information, including the Freightliner part number and switch ID of the ICU. See [Fig. 4.16](#).

ICU3

A mode/reset button, located on the right side of the ICU instrument cluster, is used to control the driver message center. See [Fig. 4.2](#). Tap the mode/reset button to advance one screen; press and hold the button to select a menu choice or reset the display. When the display resets, an audible chirp sounds.

Only four screens are accessible when the parking brake is off (mobile screens). All screens are accessible when the parking brake is on (stationary screens).

Mobile Screens

The following screens are available when the parking brake is off (when the vehicle is mobile) and no active fault codes are found. Tap the mode/reset button to scroll through the mobile screens.

- i. Odometer
- ii. Trip distance
- iii. Trip hours
- iv. Back to odometer

Stationary Screens

The following screens are available when the parking brake is on (when the vehicle is stationary) and no

Instruments

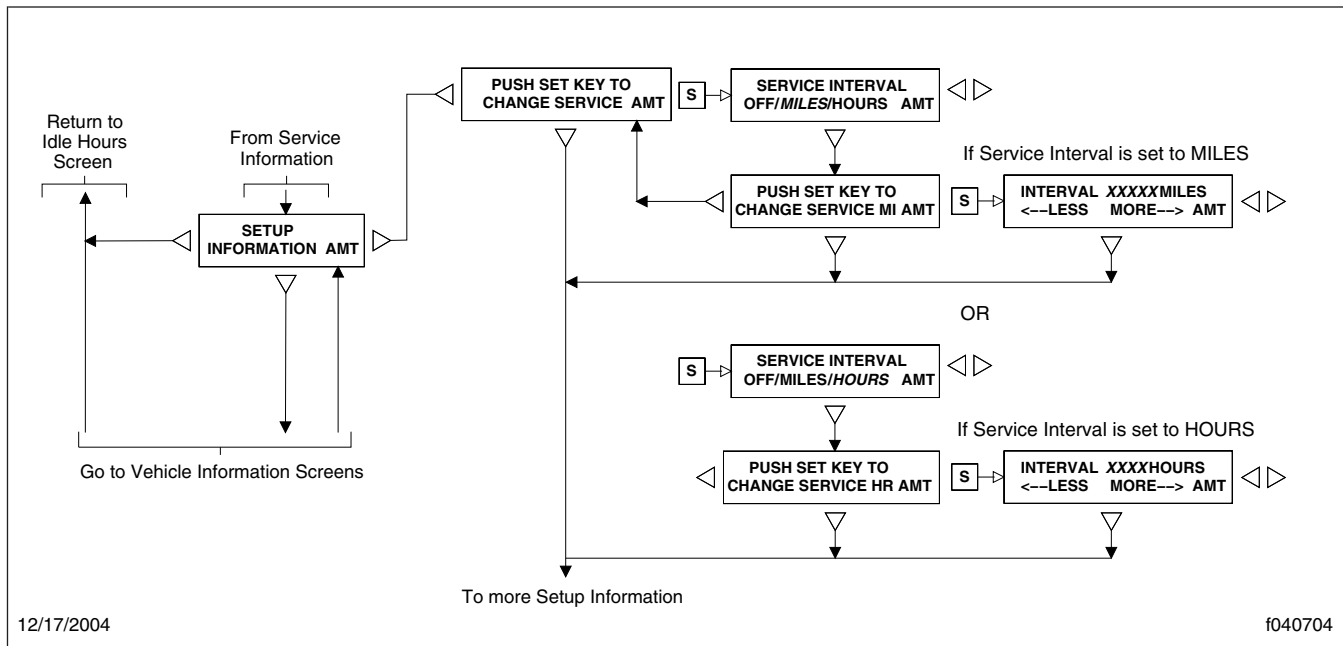

Fig. 4.14, ICU4M Setup Information Screens (for service intervals)

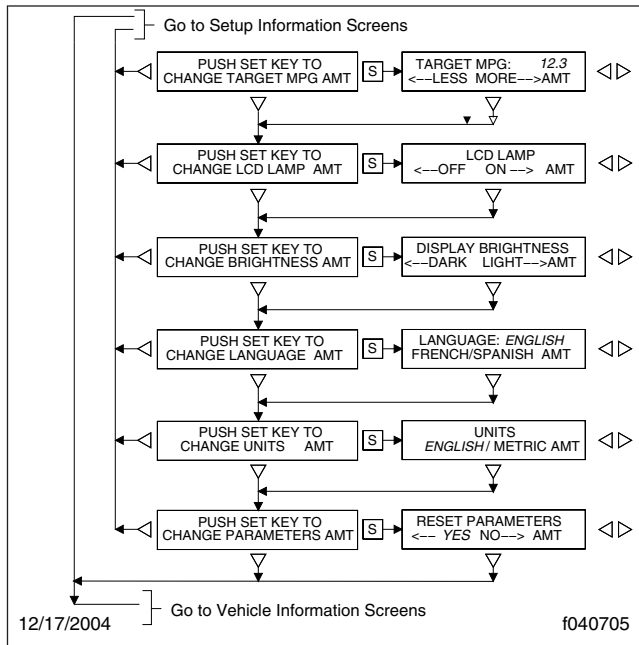

Fig. 4.15, Other Setup Information

active fault codes are found. Tap the mode/reset button to scroll through the stationary screens. See [Fig. 4.17](#).

- i. Odometer
- ii. Trip distance
- iii. Trip hours
- iv. Select units
- v. Diagnostics
- vi. Clear screen (on vehicles with less than 255 miles on the odometer)
- vii. Engine miles
- viii. Engine hours
- ix. Engine oil level
- x. Setup
- xi. Back to odometer

Trip Distance

When the odometer reading is displayed, tap the mode/reset button once for trip distance. Press and hold the mode/reset button to reset trip miles to zero.

Trip Hours

When trip distance is displayed, tap the mode/reset button once for trip hours. Press and hold the mode/reset button to reset trip hours to zero.

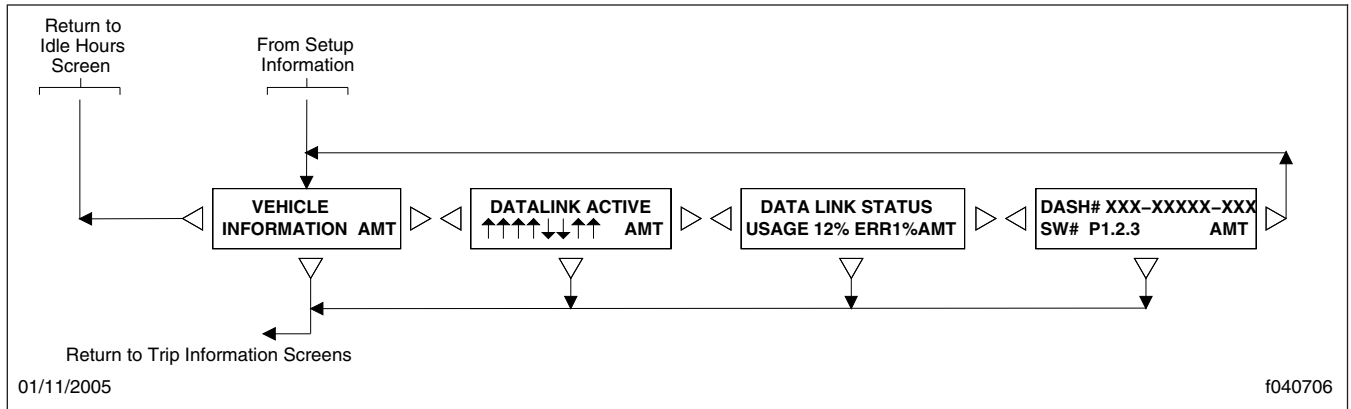

Fig. 4.16, ICU4M Vehicle Information Screens

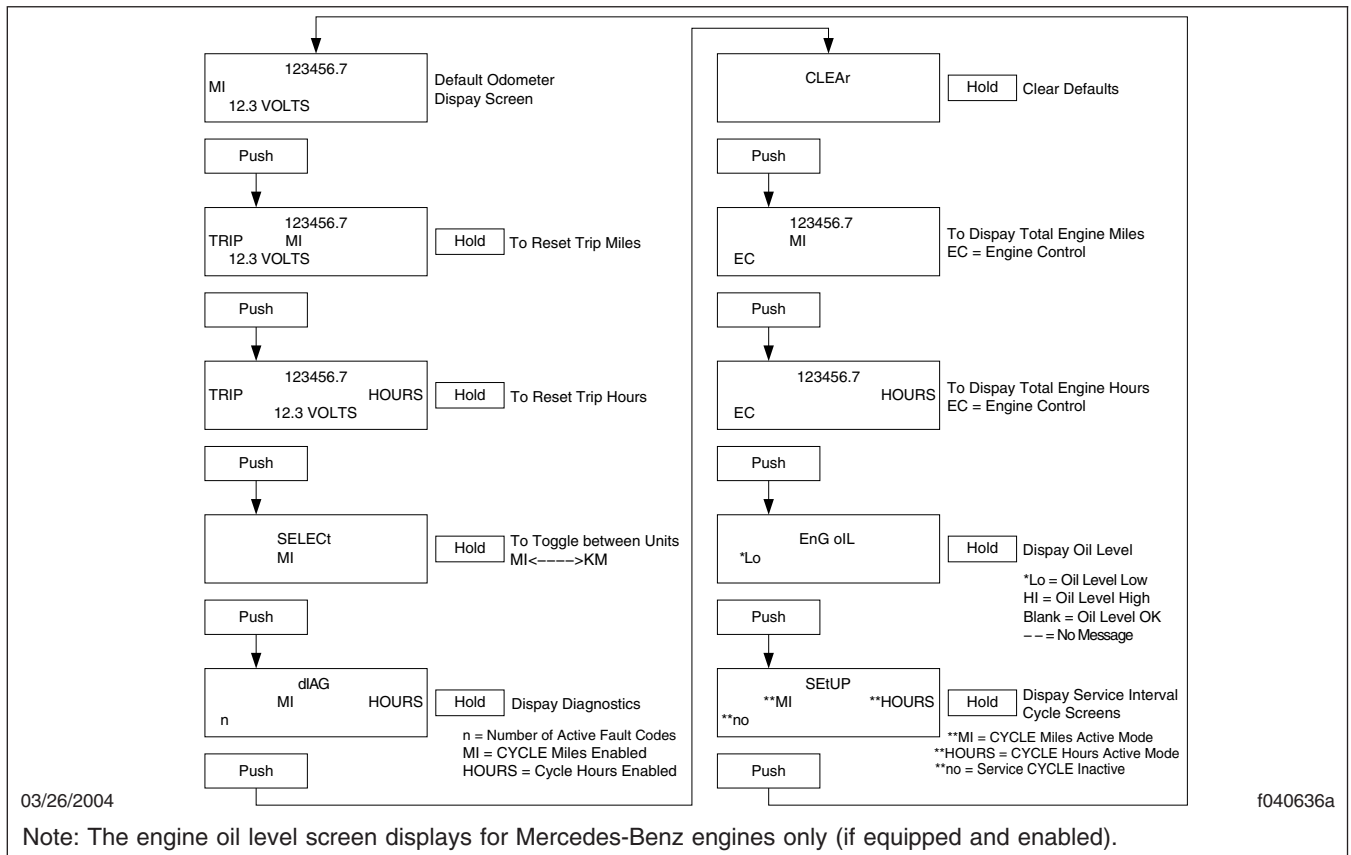

Fig. 4.17, ICU3 Stationary Screens

Diagnostic Information

When the DIAG screen is displayed, press and hold the mode/reset button to access the various diagnostic screens.

Trained technicians use the diagnostic screens to retrieve fault codes and other diagnostic information pertaining to the vehicle. If active fault codes display during start-up or at any other time, make a note of

Instruments

the fault code and take the vehicle to an authorized Freightliner service facility as soon as possible.

If fault codes are displayed, press and hold the mode/reset button to view the next fault code until reaching the DIAG screen.

If service intervals are enabled and service distance or time has been exceeded, the text SERVICE HOUR/MI (KM) will display at start-up to indicate vehicle service is required.

Engine Information

When the DIAG screen is displayed, tap the mode/reset button once to access the engine miles/hours screen. When the engine miles/hours screen is displayed, press and hold the mode/reset button to access the engines screen sub-menu.

Setup Information

The setup screen allows the driver to manage ICU parameters. When the engine hours/miles screen is displayed, tap the mode/reset button to access the setup screen. The setup screen submenu allows the driver to enable and change service intervals.

For each parameter, press and hold the mode/reset button to navigate to the parameter change screen. In each change screen, tap the mode/reset button to toggle between options.

When the setup screen is displayed again, tap the mode/reset button to view the odometer.

ICU2M

A keypad located on the auxiliary dash panel controls the driver message center. See [Fig. 4.8](#). The 10-key keypad is used to:

- call up information on mobile screens;
- navigate from screen to screen;
- set up the display;
- record significant data.

The odometer is a seven-digit display with one decimal point after the sixth digit, allowing it to display tenths of miles (or kilometers). When first installed, the odometer starts at 0.0 miles (or kilometers). When replaced, the odometer starts again from 0.0.

Alert Screens

Alert screens can appear at any time, even when the vehicle is moving. They override the regular screen display. They are warnings, cautions, or other messages that require the driver's attention, but not all of them are critical to the operation of the vehicle. The word **Warning** or **Alert** sometimes flashes on the display screen above the alert text. More important messages take priority over less important messages.

NOTE: If there is more than one alert message to display, press any button to scroll to the next message, and so on until all the messages have been viewed.

Parking Brake On

This warning message and an audible warning come on whenever the parking brake is applied and the vehicle is moving faster than 2 mph (3 km/h). The screen and audible warning go away only when the parking brake is released, or speed is reduced below 2 mph (3 km/h).

Low Oil Pressure

NOTE: All alert screens follow Low Oil Pressure alert format.

This warning message and an audible warning come on whenever the oil pressure falls below the minimum oil pressure, whether the vehicle is idling or in motion. See [Fig. 4.18](#). To dismiss the message, press any button on the keypad.

If low oil pressure is detected during the ignition sequence, it displays as an active fault and the alert screen does not appear. After 30 seconds, this message displays again.

Low Coolant Level

This warning message and audible warning activate whenever the coolant level falls below a preset point.

High Coolant Temp

This message and an audible warning come on whenever the engine coolant temperature exceeds the maximum allowable temperature.

If high coolant temperature is detected during the ignition sequence, it displays as an active fault and

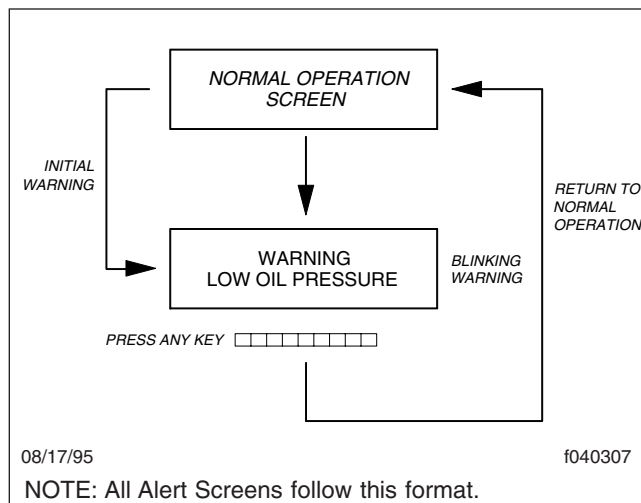

Fig. 4.18, ICU2M Alert Screen: Low Oil Pressure

the alert screen does not appear. After 30 seconds, this message displays again.

Low Voltage

On some vehicles, this optional message and an audible warning come on whenever the ICU detects a low voltage condition.

Faulty Speedo Gauge

This message is displayed when the system detects a faulty speedometer. This becomes the default screen, and vehicle speed is displayed as a digital readout at the bottom left of the screen. All other screens and functions operate normally.

Recirc Mode Engaged/Provide Fresh Air

The **Recirc Mode Engaged** message appears whenever recirculated air is selected on the fresh/air recirculation switch or the air circulation switch is rotated to the maximum air conditioning position. It displays one time only for seven seconds. It notifies the driver that recirculated air is being used and that fresh air needs to be provided after 20 minutes.

If fresh air is not provided after 20 minutes, **Provide Fresh Air** is displayed. It displays for seven seconds approximately every four minutes until the driver selects fresh air on the fresh/air recirculation switch or rotates the air circulation switch away from maximum air conditioning. See [Chapter 4](#) for detailed operating instructions for the heater/air conditioner.

Low Fuel Level

The ICU continuously monitors fuel level. When the fuel level drops to 1/8th full, the word **Warning** flashes on the message display screen above the low fuel alert.

Turn Signal On

This message (the audible warning is optional) appears whenever the turn signal remains on beyond a preset time or distance traveled.

To dismiss this message, either turn off the turn signal or press any button on the keypad.

Service Warnings

Service warning screens display during the ignition sequence and indicate that a service interval has been reached or exceeded and maintenance is required. The messages may indicate the number of miles (KM) or hours until the next required service or, once passed, the number of miles (KM) or hours ago that maintenance should have been performed. The ICU2M can be programmed using ServiceLink to generate service warnings in either miles or hours, but not both.

No Datalink Activity

This message appears whenever the datalink is not receiving data. If the condition persists, take the vehicle in for service as soon as possible to discover the cause of the problem.

Mobile Screens

The following screens are available when the parking brake is off (when the vehicle is mobile) and no active fault codes are found. Press the appropriate button on the keypad to display one of the mobile screens.

- trip miles and hours
- fuel used and average MPG
- leg miles and hours

NOTE: Resetting trip miles and hours also resets leg miles and hours.

To reset a mobile screen, push the Set/Reset button twice within a 6-second period while the screen is displayed. A confirmation screen will display after you press the button once.

Instruments

NOTE: If the memory in the data logger is full, the screen will display **Memory Full Data Not Recorded**. If the data logger is not connected or not responding, the screen will display **Data Recorder Not Responding**. If the EVENT button was pressed within the last two minutes, the screen will display **Still Recording Last Event**.

Stationary Screens

The following screens are available when the parking brake is applied (vehicle is stationary) and no active fault codes are found. Each set of stationary screens has a title screen followed by one or more data screens.

To move forward and backward through these screens, use the three arrow buttons on the keypad. See Fig. 4.19, Fig. 4.20, and Fig. 4.21 for stationary screen navigation.

- i. Trip Information: miles, hours
- ii. Fuel information: fuel used, average MPG

- iii. Engine information: engine miles and hours, engine gallons and PTO gallons
- iv. Diagnostic information: active faults, historical dash faults
- v. Setup Information: target MPG, brightness, language, units of measurement
- vi. Vehicle information: datalink activity/status, ICU part number, software ID number

Overhead Instrument Panel

The optional overhead instrument panel may hold a citizen's band (C/B) radio, digital clock, storage pocket areas for sunglasses and maps, and a locked glove box.

The underside of the overhead console also holds the sun visors and the optional dome/reading light assembly. See Chapter 5 for more information on the dome/reading light assembly.

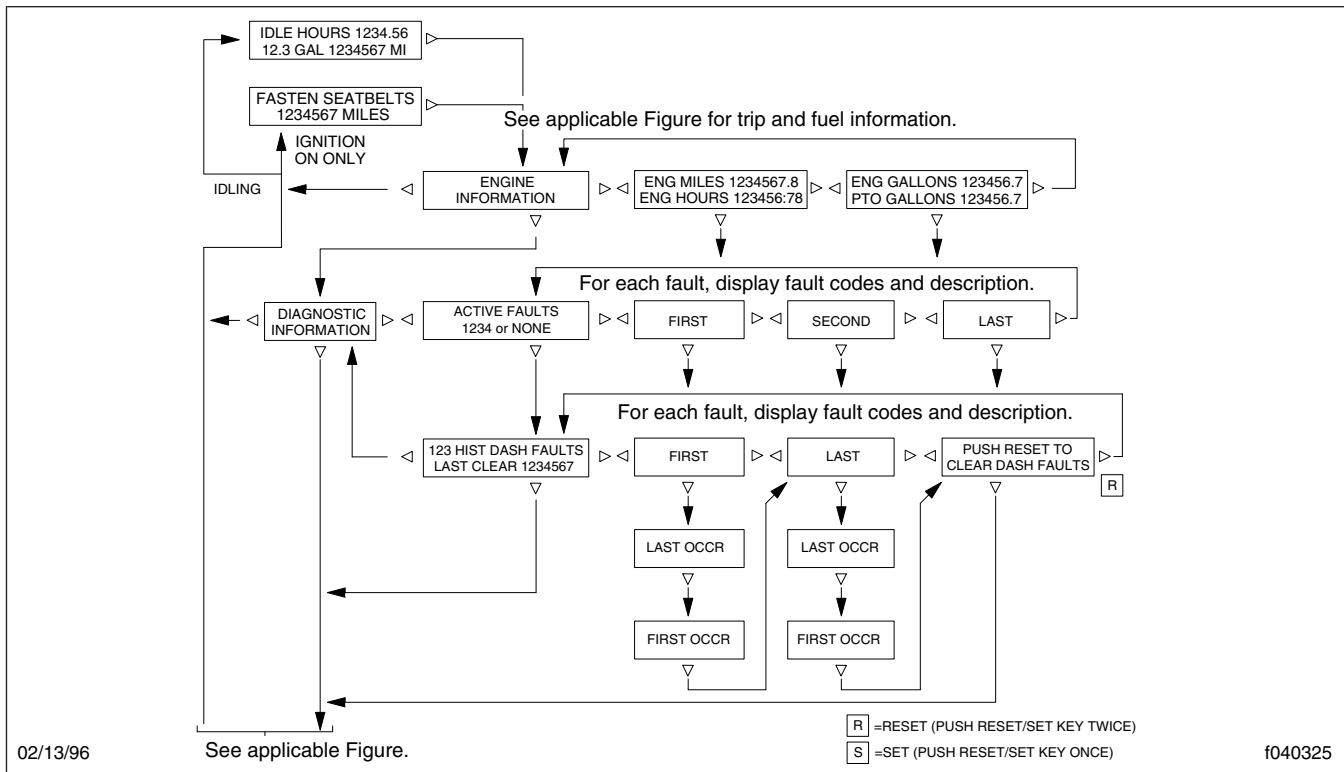

Fig. 4.19, ICU2M Engine Information and Diagnostic Information

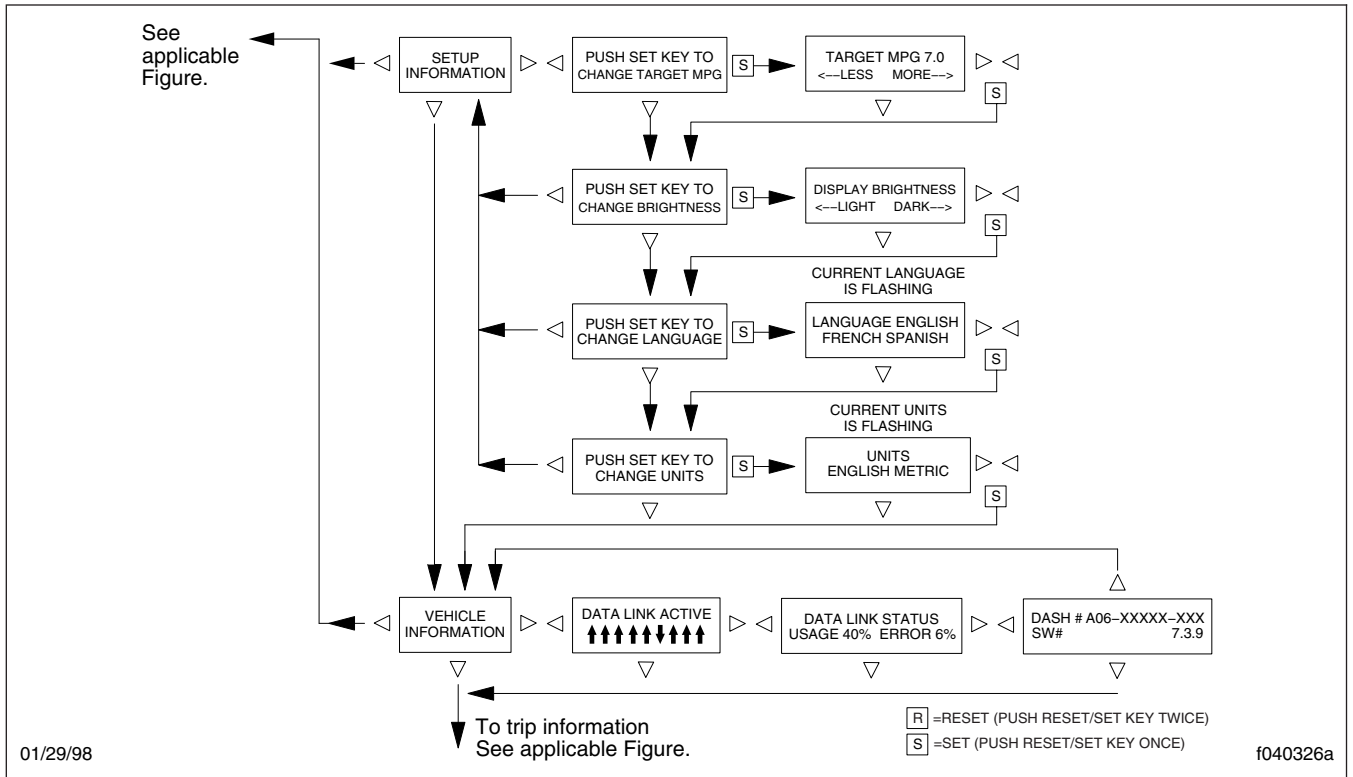

Fig. 4.20, ICU2M Setup Information and Vehicle Information

Instruments

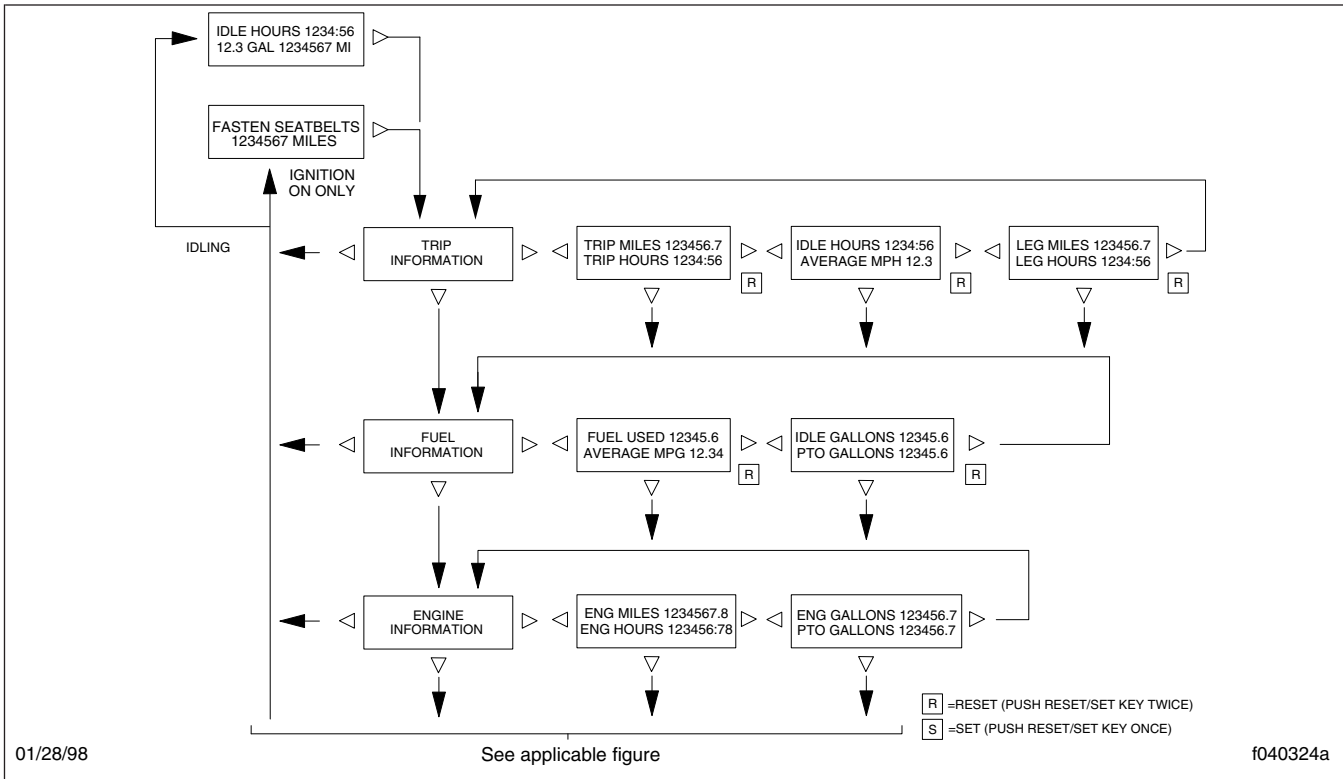

Fig. 4.21, ICU2M Trip Information, Fuel Information, and Engine Information

5

Driver Controls

Ignition Switch and Key	5.1
Lighting Controls	5.2
Horn Controls	5.4
Powertrain Controls	5.5
Cruise Control	5.7
Dash-Mounted Brake Controls	5.8
Windshield Wiper/Washer Controls	5.10
Suspension/Trailer Connection Controls	5.10
Climate Controls	5.11
Seat Controls	5.12
Adjustable Steering Column Controls	5.12

Driver Controls

Ignition Switch and Key

The ignition switch has four positions: OFF, ACC (accessory), ON, and START. See [Fig. 5.1](#). The ignition key also locks and unlocks the cab doors, baggage door(s), and if equipped, the bunk door(s).

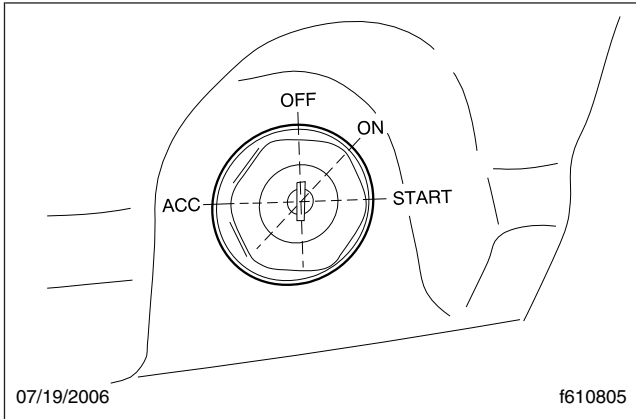

Fig. 5.1, Ignition Switch

In the OFF position, the ignition switch is vertical. The key can be inserted and removed only in the OFF position.

The following functions are operable when the ignition switch is in the OFF position (regardless of whether the key is inserted):

- low-beam headlights
- taillights
- brake lights
- road lights
- dome lights
- clearance lights
- hazard warning lights
- turn signals
- utility lights
- baggage compartment lights
- spotlights
- electric horn
- clock
- refrigerator

- CB radio
- power mirrors
- power receptacle
- fuel heater
- electric oil pan heater
- electric or diesel-fired engine coolant pre-heater

Turn the key counterclockwise to reach the ACC position. In addition to all the functions that are operable in the OFF position, the following functions are operable when the switch is in the ACC position:

- radio/stereo system
- heater and A/C fan
- mirror defog
- windshield fan
- ether start system
- air dryer
- backup lights

Turn the key clockwise past the OFF position to reach the ON position. When the ignition is turned on, the following actions should occur:

- electronic gauges complete a full sweep of their dials
- warning and indicator lamps illuminate, then are extinguished
- audible alert sounds for approximately four seconds or until sufficient air pressure builds up in the primary and secondary air systems
- software revision level of the ICU is displayed on the driver message center, followed by any active faults

IMPORTANT: If any red or amber warning or indicator lamps do not illuminate during the ICU self-check or do not extinguish after the self-check completes, take the vehicle to an authorized Daimler Trucks service facility as soon as possible.

IMPORTANT: Do not crank the engine until the ICU gauge sweep is complete.

Turn the key clockwise past the ON position to reach the START position to start the engine. Release the key the moment the engine starts. Do not operate the starter longer than thirty seconds, then allow the starter to cool between attempts. If the starter overheats, the starter protection system will prevent operation of the starter until it has cooled. Release the key the moment the engine starts.

Lighting Controls

Exterior Lighting Controls

Exterior light controls are listed here in alphabetical order.

Backup Lights

Backup lights provide a warning to pedestrians and other drivers that the vehicle is, or is about to, back up.

Daytime Running Lights

The daytime running lights (DRL), if equipped, are automatically activated when the ignition is switched on and the parking brake is released. The DRL operate until the parking brake is applied or the headlights are turned on.

Some vehicles may be equipped with a momentary DRL override switch. See [Fig. 5.2](#). Press the upper half of the switch to briefly deactivate the DRL.

Fog Lights

Fog lights are designed to reduce glare in foggy conditions. The low-beam headlights must be on in order to turn the fog lights on. Press the upper half of the switch to activate the fog lights. See [Fig. 5.2](#).

Hazard Warning Lights

The hazard warning light switch tab is located below the turn signal lever. Pull the tab out to activate the hazard warning lights. When the hazard warning lights flash, all turn signal lamps and both of the indicator lights on the control panel will flash. Move the turn signal lever up or down to cancel the warning lights.

Headlights

A three-position paddle switch is used to operate the exterior lights. See [Fig. 5.2](#). Move the paddle switch

up to activate the headlights, instrument panel, clearance lights, marker lights, and taillights. To deactivate all vehicle lighting, ensure the switch is in the middle position. Move the paddle switch down to activate only the clearance, instrument panel, marker lights, and the taillights.

High-Beam Headlights

To activate the high-beam headlights, pull the turn signal lever towards the driver while the low-beam headlights are on. Pull the turn signal lever back again to deactivate the high beams and return to low beam headlights.

When the high-beam headlights are on, a blue light illuminates on the instrument cluster.

NOTE: The ignition switch must be on for the high beams to work.

Marker Light Interrupt

A momentary interrupt switch temporarily deactivates the marker lights and taillights. With the vehicle lights on, press and release the interrupt switch to briefly turn the marker lights and taillights off. To alert the driver that the switch is functioning, the dash lights will flash with the marker lights when the switch is actuated.

Road Lights

Press the upper half of the road light switch to activate the road lights mounted on the bottom edge of the front bumper or recessed in the front bumper. See [Fig. 5.2](#).

Spotlight

The spotlight switch is located on the pivoting handle of the spotlight. There may be a single spotlight assembly mounted above the driver's door, or one above each door.

Turn Signals

The turn signal lever is mounted on the steering column. Push the lever down to activate the left-turn signal lights; pull the lever up to activate the right-turn signal lights. To manually cancel the signal, move the lever to the neutral position. When a turn signal is activated, a green indicator light flashes on the instrument cluster.

Driver Controls

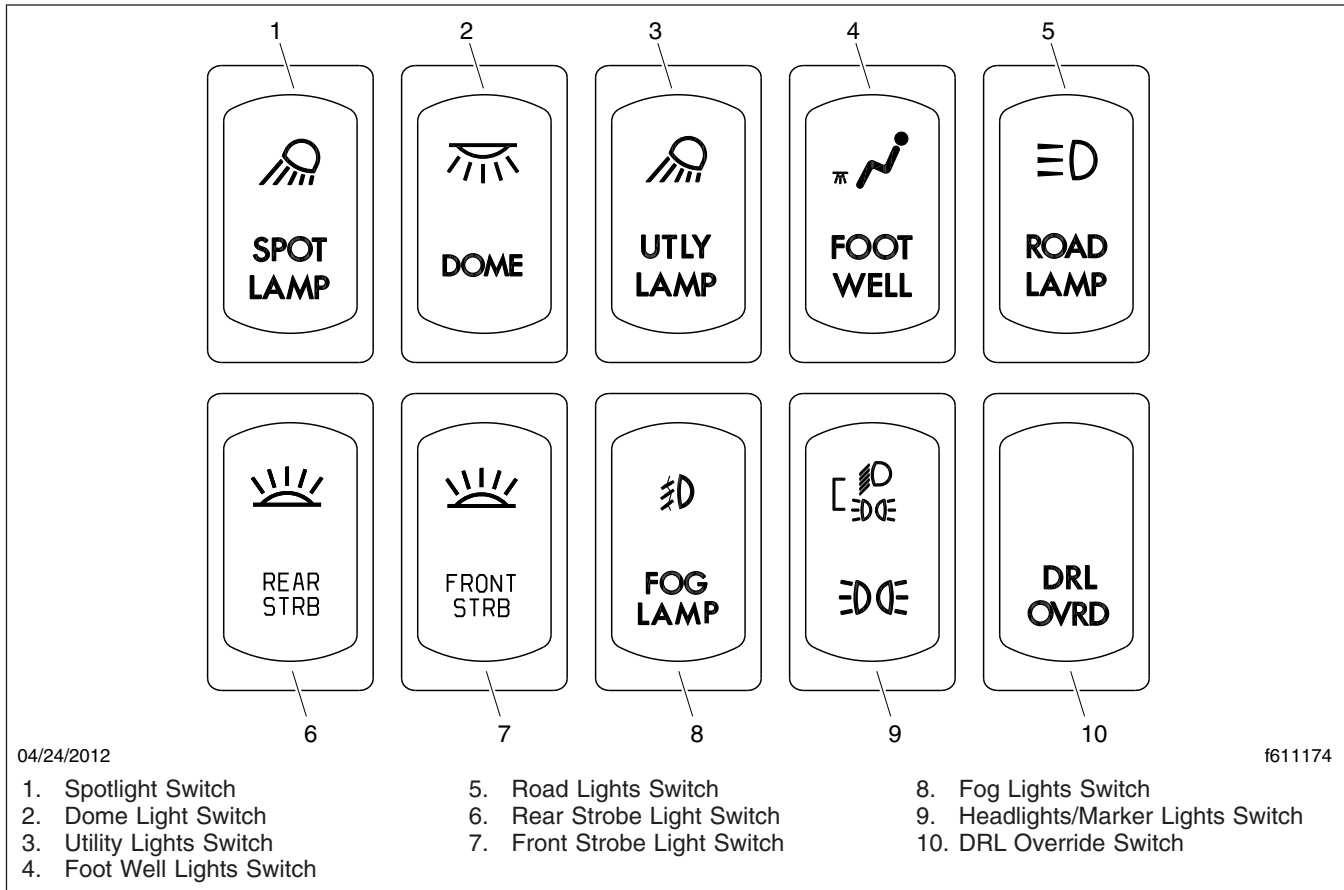

Fig. 5.2, Typical Light Controls

Utility Lights

Utility lights can be swivel-mounted on top of the cab, mounted on the intake/exhaust support, or flush-mounted in the back of the cab or sleeper. Press the upper half of the switch to activate the utility lights. See [Fig. 5.2](#). Press the lower half of the switch to turn the utility lights off. When activated, a red indicator light in the switch is illuminated, if equipped

Interior Lighting Controls

Interior light controls are listed here in alphabetical order.

Baggage Compartment Lights

Baggage compartment lights are located on the underside of the lower bunk, on both sides. Both lights turn on when either baggage compartment door is

opened to illuminate the baggage compartment. The lights also come on when the lower bunk is raised.

Cab Overhead Console Lights

The overhead console includes a clear reading light, a clear dome light, and a red map light. The dome lights illuminate when a door opens, then stay on for a short time after both doors are closed. Press the lens of the reading light, dome light, or map light to activate each one.

Foot Well Lights

When the driver or passenger doors are opened, red lights illuminate both foot wells. These lights can also be activated with the foot well light switch. See [Fig. 5.2](#). Press the upper half of the switch to turn the foot well lights on, press the lower half of the switch to turn them off.

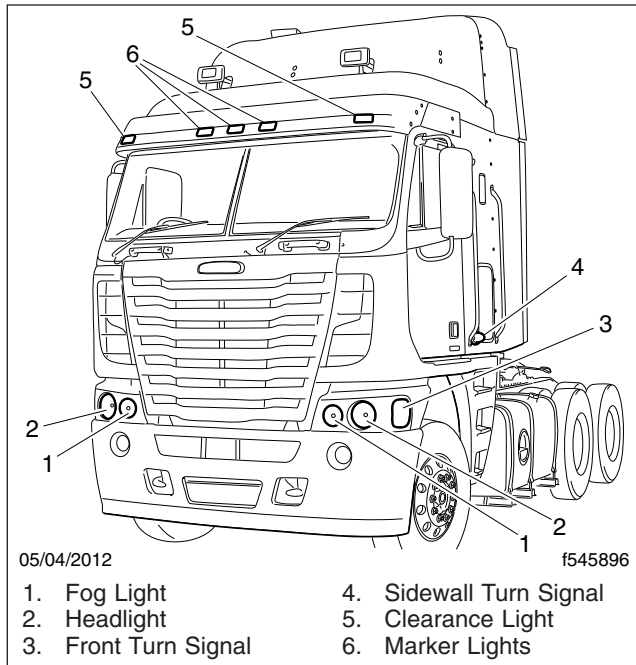

Fig. 5.3, Exterior Lights

The sleeper foot well switch is located in the lower switch module in the sleeper. It looks identical to the cab foot well switch. See [Fig. 5.2](#). When the switch is activated, two lights illuminate the sleeper floor.

Instrument Panel Lights

The instrument panel lights illuminate when the headlights are turned on. When the headlights are on, the panel lamp switch controls the intensity of the instrument panel lamps. Slide the switch up to brighten them and down to dim them. When the headlights are turned on, the panel lights setting will default to the intensity that was last set.

Sleeper Dome Light

A sleeper dome light is located on the roof, between the bunk and the cab on sleeper vehicles. See [Fig. 5.4](#). The rear cab dome light will activate with the dome lights when a door is opened, then stay on for a short time after both doors are closed.

Use the dash-mounted switch or the switch in the sleeper panel to activate the rear cab dome light. See [Fig. 5.2](#).

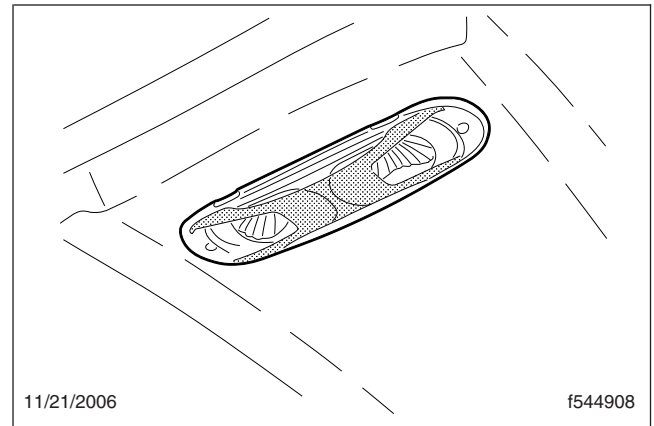

Fig. 5.4, Sleeper Dome Light

Rear-Wall Dome Light

A rear-wall dome light is available on all sleeper cabs. It is located on the rear wall where the wall meets the roof. To turn on the rear-wall fluorescent light, press the dome light switch on either the lower or upper bunk control panels. See [Fig. 5.5](#).

Sleeper Reading Lights

Clear reading lights are mounted above the lower bunk in the rear corners of the sleeper. There are two switches in the sleeper control panel for the reading lights. To turn a reading light on, press the upper half of the switch. Press the lower half of the switch to turn it off. See [Fig. 5.5](#).

The reading lights can also be activated by pressing the lens.

Horn Controls

Air Horn

Air horn(s) may be mounted on the roof of day cabs, or under the driver-side floor for sleeper cabs. The air horn is controlled by a wire lanyard that hangs down inboard by the driver's door. See [Fig. 5.6](#). Pull downward on the lanyard to sound the air horn.

Electric Horn

The button for the electric horn on a vehicle without an airbag is located in the center of the steering wheel. To sound the horn, press down on the button.

Driver Controls

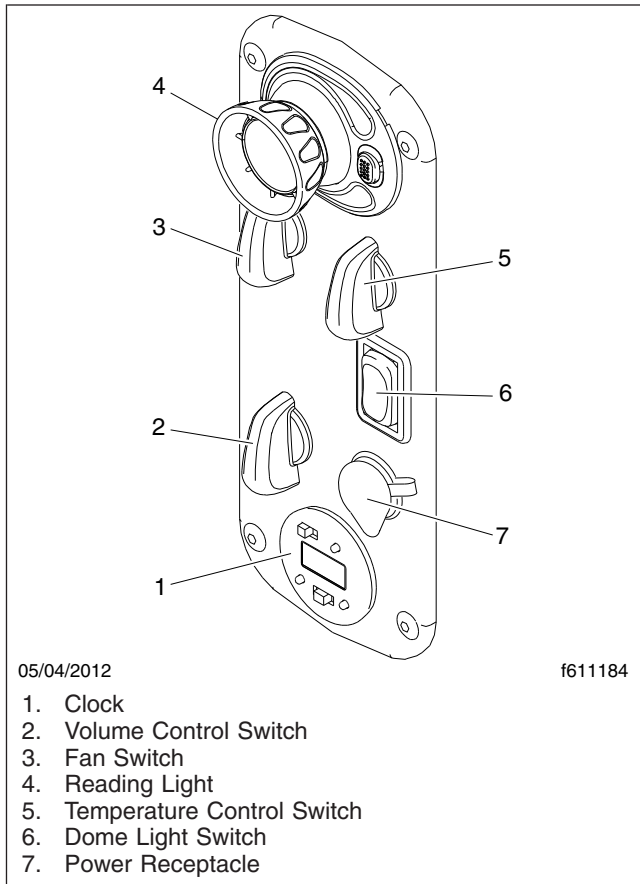

Fig. 5.5, Sleeper Climate Control Panel

The electric horn on a vehicle with an airbag is activated by pressing down on the top of the steering wheel center pad.

The horn will sound for the duration that the button is pressed, up to 60 seconds. The electric horn will operate regardless of the position of the ignition key.

Powertrain Controls

Aftertreatment System Regen Switches

NOTE: See [Chapter 11](#) for detailed information about the operation of the regeneration (regen) switches and the aftertreatment system (ATS).

IMPORTANT: Depending upon local jurisdictional emissions guidelines, the vehicle may not

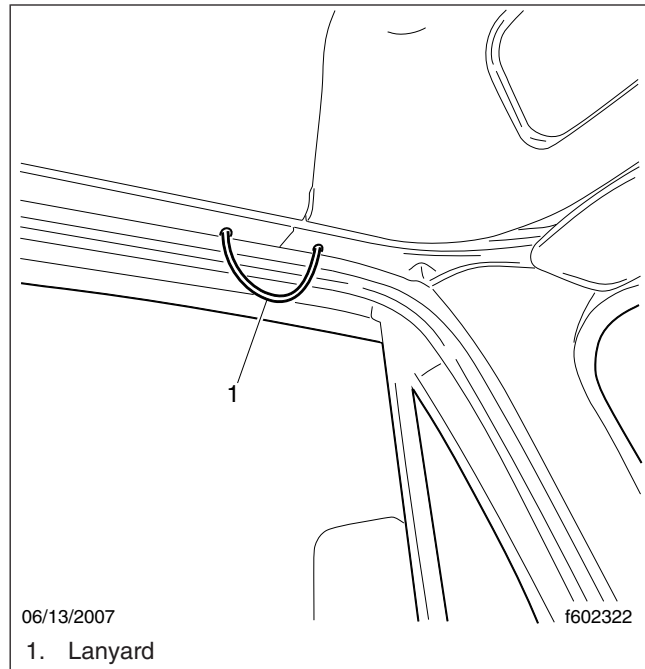

Fig. 5.6, Air Horn Control

be equipped with an emissions aftertreatment system (ATS).

The regen request switch, located on the dash, is used to initiate a parked regen. See [Fig. 5.7](#).

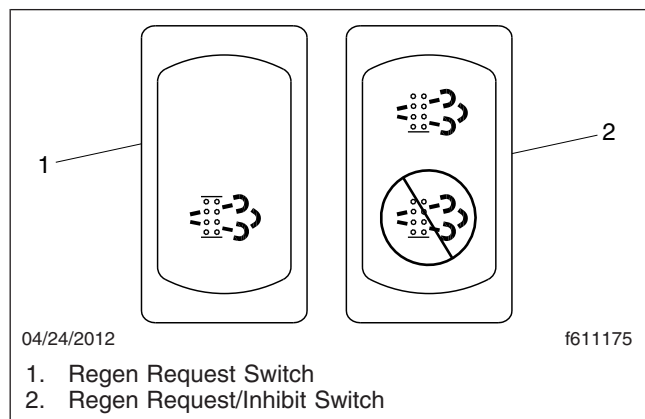

Fig. 5.7, ATS Regen Switches

NOTE: The regen switch can initiate a parked regen only when the DPF lamp is illuminated.

Some vehicles may be equipped with a regen request/inhibit switch. See [Fig. 5.7](#). To stop a regen in progress or prevent the start of a regen, press the

lower half of the switch. Regen will be delayed until the switch is no longer active.

Axle Switches

Differential Lock Switch

The differential lock switch provides maximum traction for slippery conditions by forcing the wheels on each drive axle governed by the switch to rotate together. Engagement can be at any speed, provided the wheels are not slipping or spinning. See [Fig. 5.8](#).

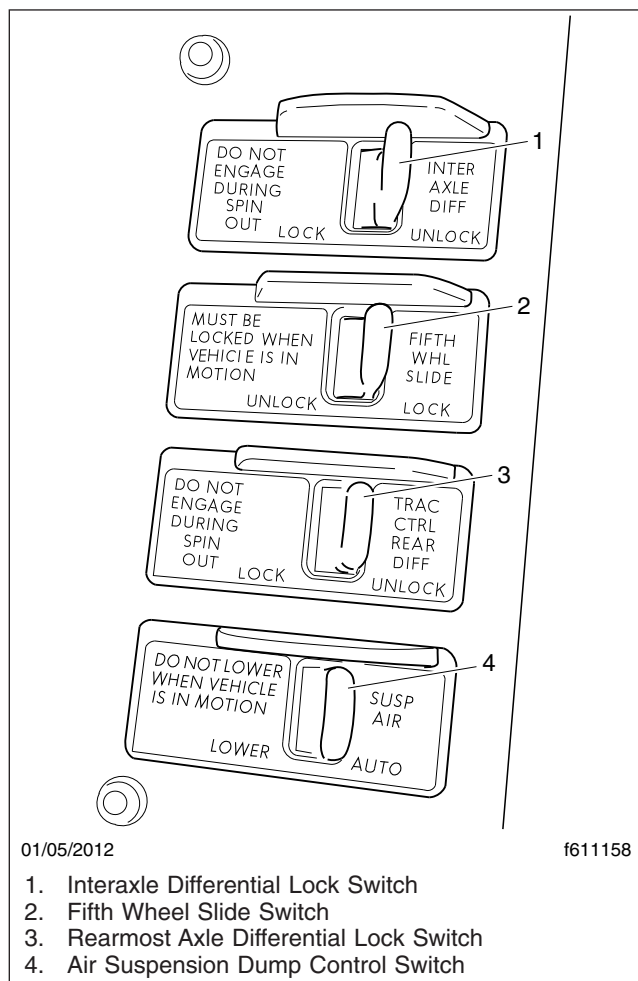

Fig. 5.8, Axle and Suspension Switches

Interaxle Lock Switch

The interaxle lock, standard on all dual-drive vehicles, is driver-actuated by means of a LOCK/

UNLOCK control valve switch. See [Fig. 5.8](#). A red indicator illuminates when the interaxle lock is engaged.

NOTICE

The interaxle lock should only be engaged when the vehicle is moving slowly at low throttle. Engagement at high speed or power can damage the axle(s).

Do not permit rear wheels to spin freely for more than ten seconds when traction is lost. Shift into LOCK to prevent damage to interaxle and main differentials.

Engine Fan Switch

To turn the engine fan on, press the upper half of the engine fan switch. See [Fig. 5.9](#). The fan will continue to operate for a set amount of time and then turn off unless the coolant temperature is high enough to continue fan operation. To turn the fan off before the set time period ends, press the lower half of the switch.

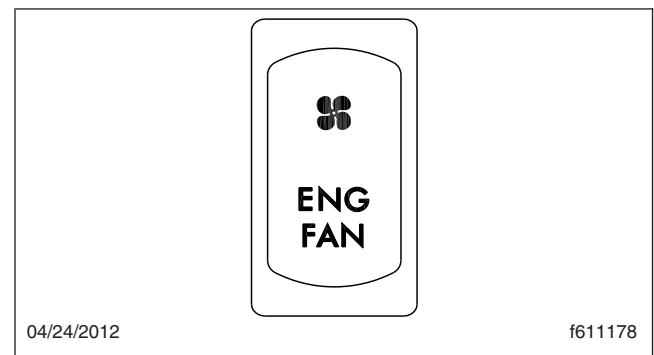

Fig. 5.9, Engine Fan Switch

Hill Start Aid Override Switch

Some vehicles are equipped with a Hill Start Aid (HSA) feature to prevent the vehicle from rolling while on steep grades and to allow for a controlled launch. HSA is active by default. It can be turned off by pressing and releasing the HSA override switch on the dash (see [Fig. 5.10](#)).

Driver Controls

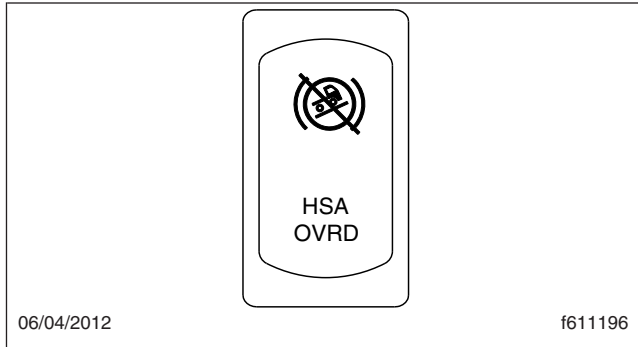

Fig. 5.10, Hill Start Aid Override Switch

PTO Switch

To activate the PTO function, press the upper half of the switch. Press the lower half of the switch to deactivate the PTO function.

Transmission Controls

Manual Transmissions

NOTE: See [Chapter 14](#) for complete manual transmission operating instructions.

If so equipped, the transmission range control and splitter valves are attached to the gear shift knob.

The range-preselection lever allows the selection of the low or high range for each transmission ratio. It is used once during an upshift sequence and once during a downshift sequence.

Depending on the transmission model, some ratios can be split using the splitter-control button.

Eaton Automated Transmissions

NOTE: See [Chapter 15](#) for complete automated transmission operating instructions.

The SmartShift electronic transmission control is installed with the Eaton® Fuller® UltraShift™ and Eaton Fuller AutoShift™ transmissions. The SmartShift control is operated by the fingers of the driver's right hand, allowing both hands to remain on the steering wheel.

A two-position driving mode slide switch is mounted on the body of the control lever just before the paddle widens out. The slide switch allows the driver to choose automatic (AUTO) or manual (MAN) mode. See [Fig. 5.11](#).

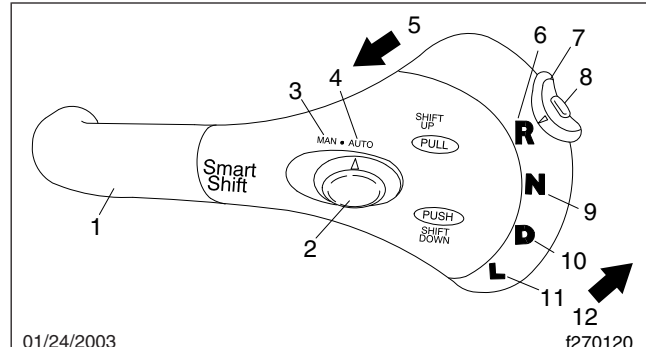

01/24/2003

f270120

To upshift manually, pull the lever back (towards the driver). To downshift manually, push the lever forward (away from the driver).

1. SmartShift Control Lever
2. Slide Switch (forward driving mode switch)
3. MAN Mode (of slide switch)
4. AUTO Mode (of slide switch)
5. Upshift Direction
6. Reverse Position (of selector switch)
7. Selector Switch
8. Neutral Lock Button
9. Neutral Position (of selector switch)
10. Drive Position (of selector switch)
11. Low Position (of selector switch)
12. Downshift Direction

Fig. 5.11, SmartShift Control (Eaton Fuller UltraShift and AutoShift transmissions)

Cruise Control



Do not use the cruise control system when driving conditions do not permit maintaining a constant speed, such as in heavy traffic or on roads that are winding, icy, snow-covered, slippery, or roads with a loose driving surface. Failure to follow this precaution could cause a collision or loss of vehicle control, possibly resulting in personal injury or property damage.

NOTICE

When the cruise control is engaged, do not attempt to shift gears without using the clutch pedal. Failure to follow this precaution will result in a temporarily uncontrolled increase in engine speed. Transmission damage and gear stripping could result.

Cruise control is activated by two dash-mounted switches: an On/Off switch and a Set/Decelerate/Resume/Accelerate switch. See [Fig. 5.12](#).

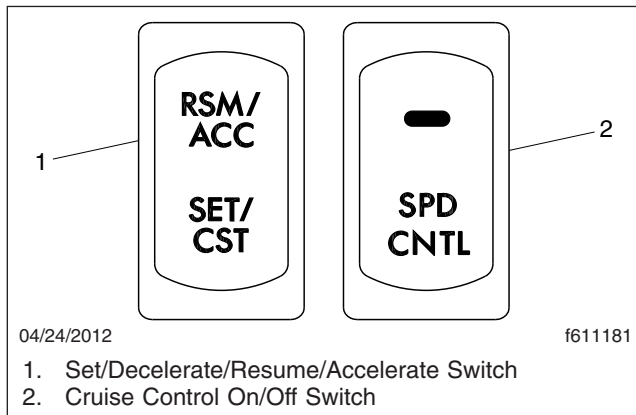

Fig. 5.12, Cruise Control Switches

Cruise at a particular speed

1. Press the upper part of the cruise control On/Off switch to turn cruise control on.
2. Hold the accelerator pedal down until the speedometer reaches the desired speed.
3. Press the lower half of the Set/Resume/Accelerate/Decelerate switch momentarily to set the cruise speed (with the vehicle moving at the desired speed).

To decrease cruise speed, press and hold the lower half of the Set/Resume/Accelerate/Decelerate switch to decelerate slowly. Release the switch when the desired speed is achieved.

To increase cruise speed, press and hold the upper half of the Set/Resume/Accelerate/Decelerate switch to accelerate slowly. Release the switch when the desired speed is achieved.

Disengage cruise control

NOTE: The speed memory is lost whenever the ignition is turned off or the cruise control system is turned off.

1. Depress the brake pedal (automatic or manual transmissions)
or
Depress the clutch pedal (manual transmissions only).

2. Press the lower half of the On/Off switch.

NOTE: To resume the preselected cruise speed, increase vehicle speed to above minimum cruise control speed and momentarily press the upper half of the Set/Resume/Accelerate/Decelerate switch. Cruise will return to the last speed selected.

Dash-Mounted Brake Controls

NOTE: See [Chapter 12](#) for detailed information about brake systems.

Antilock Braking System

The Meritor™ WABCO® Antilock Braking System (ABS) passively monitors vehicle wheel speed at all times, and controls wheel speed during emergency stops or wheel lock situations.

During emergency or reduced-traction stops, fully depress the brake pedal until the vehicle comes to a safe stop. *Do not pump the brake pedal.* With the brake pedal fully depressed, the ABS will control all wheels to provide steering control and a reduced braking distance.

The ABS is designed to communicate with a trailer ABS, if they are compatible. Compatibility will result in the illumination of the trailer ABS lamp during vehicle start-up and fault detection. The trailer ABS lamp will not illuminate unless a compatible trailer is connected to the tractor.

Vehicles with ABS may have Automatic Traction Control (ATC). On these vehicles, the ATC system automatically limits wheel spin during reduced-traction situations. In normal braking applications, the standard air brake system is in effect.

ATC includes a deep snow and mud option to increase available traction on extra-soft surfaces like snow, mud, or gravel. A switch labeled ATC will be located on the dash. See [Fig. 5.13](#). Press the switch to temporarily activate the snow/mud option. The activation of the deep snow and mud option is indicated by a flashing WHEEL SPIN lamp. Press the switch again to cycle the system back to normal operation.

Driver Controls

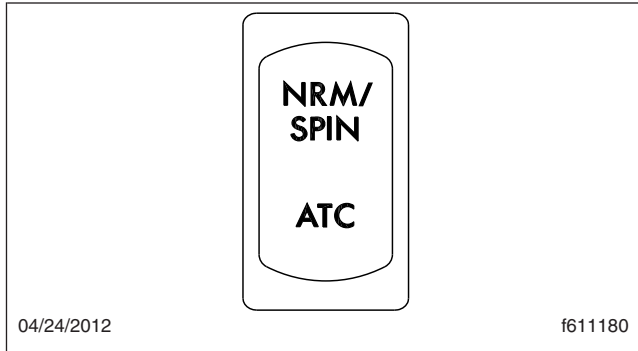

Fig. 5.13, ATC Switch

NOTICE

The deep snow and mud option is intended to be used under specific slippery conditions that require momentary increased wheel spin. Using this option for an extended period of time may damage the brake system.

Engine Brake Switch

The Hi/Med/Lo engine brake 3-position switch controls the amount of engine braking. Press the lower third of the switch for low, center for medium, and upper third for high. See Fig. 5.14.

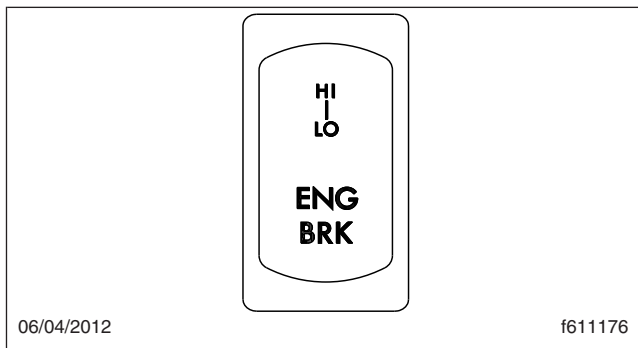

Fig. 5.14, Engine Brake Switch

Parking Brake Control Valve

NOTICE

Do not step on the service brake pedal while the parking brakes are applied. To do so can cause damage to the brake mechanisms.

The yellow diamond-shaped knob operates the parking brake valve. See Fig. 5.15. Pull the knob out to apply the tractor and the trailer spring parking brakes. Push the knob in to release the spring parking brakes. Before the spring parking brakes can be released, the air pressure in either air brake system must be at least 65 psi (447 kPa).

If the trailer is not equipped with spring parking brakes, pull the parking brake valve out to apply the tractor parking brakes and the trailer service brakes.

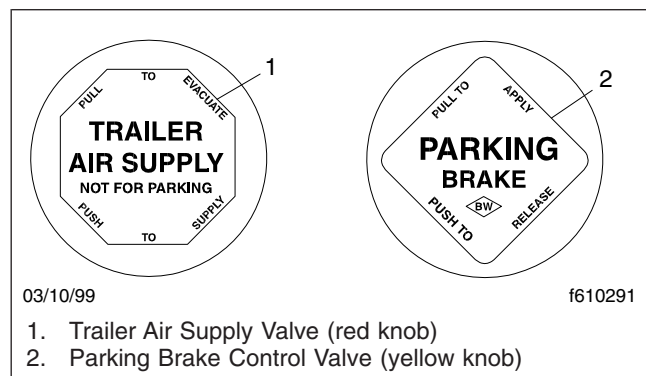

Fig. 5.15, Brake Valve Control Knobs

Trailer Air Supply Valve

The red octagonal-shaped knob operates the trailer air supply valve, which charges the trailer air supply system and releases the trailer spring parking brakes. See Fig. 5.15.

After the vehicle and its air hoses are connected to a trailer and the pressure in the air system is at least 65 psi (447 kPa), push the trailer air supply valve knob in (and leave it in) to charge the trailer air supply system and release the trailer spring parking brakes. Pull the trailer air supply valve out before disconnecting a trailer or when operating a vehicle without a trailer.

Trailer Brake Lever

The trailer brake lever is used to apply the trailer service brakes without applying the truck or tractor service brakes. It is usually mounted on the right-hand control panel. See Fig. 5.16. The valve can be partially or fully applied, but in any partially on position it will be overridden by a full application of the service brake pedal. Move the lever down to apply the trailer brakes; move the lever up to release the trailer

brakes. The lever will automatically return to the up position when it is released.

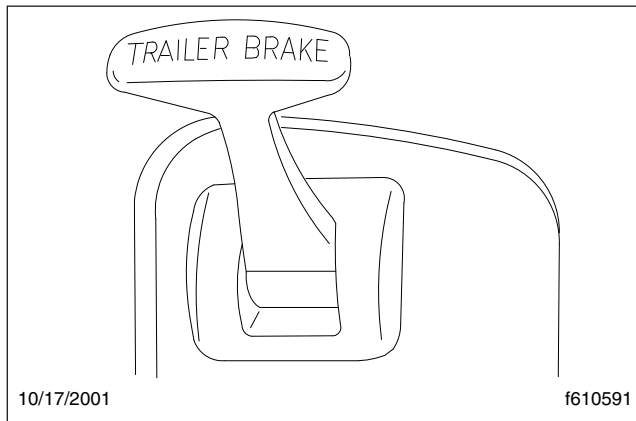

Fig. 5.16, Trailer Brake Lever

Windshield Wiper/Washer Controls

NOTICE

Do not attempt to manually move the windshield wiper arms. Wiper motor damage will occur if the arms are forcibly moved.

The wipers are operated by a dual paddle switch located on the auxiliary instrument panel. See [Fig. 5.17](#). To turn the wipers on or off, press the top paddle in. When the top paddle is pushed up, the wipers will operate at high speed; when it is pushed down, they will wipe at low speed.

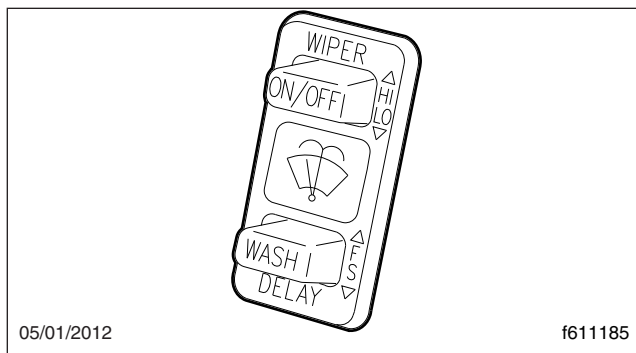

Fig. 5.17, Windshield Wiper Switch

The bottom paddle, when pushed in, turns the washers on. When pressed for less than 1/2-second,

the wipers will perform a single, low speed dry wipe (mist function). When pressed for more than 1/2-second, the wash cycle begins and continues for three cycles or until the paddle is released. When the bottom paddle is pushed up, the wipers operate in fast delay. When the bottom paddle is pushed down, the wipers operate in slow delay. With the wipers in delay mode (fast or slow), push the bottom paddle up to shorten the delay period, or push the paddle down to lengthen it.

Suspension/Trailer Connection Controls

Air Suspension Dump Control Switch

NOTICE

Do not operate the vehicle over uneven ground such as ramps, speed bumps, curbs, etc. with the air springs deflated. Doing this may lead to air bag separation from the piston, preventing the suspension air springs from re-inflating.

The air suspension height control switch may be used to aid in connecting or disconnecting from a trailer. See [Fig. 5.8](#). When the switch is set to LOWER, the air suspension dump valve deflates the air springs to lower the rear of the vehicle. In the AUTO position, the automatic ride-control valves operate for normal driving.

NOTICE

Never exhaust air from the suspension while driving. When the air is exhausted, the suspension will not absorb road shocks, and components may be damaged.

A red LED in the switch is illuminated when the suspension is deflated.

Fifth Wheel Slide Control Switch

NOTICE

Do not activate the fifth wheel slide control valve while the vehicle is in motion. To do so could cause damage to the fifth wheel member, the kingpin, the cab or trailer, and ultimately to the drivetrain.

Driver Controls

The fifth wheel air slide valve allows repositioning of the sliding fifth wheel from inside the cab. See [Fig. 5.8](#). Move the air slide control valve switch to the LOCK position to lock the fifth wheel to the baseplate. Move the switch to the UNLOCK position to unlock the fifth wheel slide mechanism, allowing changes to the total length of the tractor-trailer and changes to axle loads to comply with state or provincial laws.

For detailed operating instructions for fifth wheel slide, refer to [Chapter 17](#). A red indicator light illuminates whenever the fifth wheel slide is unlocked.

Trailer Auxiliary Switch

Some trailers with pneumatic brakes are equipped with power for the trailer lights. The connection is passed from the vehicle to the trailer via the primary receptacle, controlled by a dash switch.

Press the top of the switch to activate the trailer auxiliary function. Press the bottom of the switch to turn trailer auxiliary function off.

Climate Controls

NOTE: See [Chapter 6](#) for detailed climate control panel operating instructions.

Cab Climate Control

The climate control panel allows the control of heating, ventilating, defrosting, and air conditioning (A/C) functions. See [Fig. 5.18](#). The cab climate control panel has three knobs to control the functions of the cab temperature system:

- fan switch
- air selection switch
- temperature control switch

The fan switch controls the fan speed, and forces fresh or recirculated air through the air outlets. To increase airflow, turn the switch clockwise to a higher number. To decrease airflow, turn the switch counterclockwise to a lower number.

The air selection switch allows the control of air flow through the face outlets, the floor outlets, the defrost (windshield) outlets, or a combination of these outlets.

The temperature control switch is used to select the desired temperature. Turn the switch clockwise to the

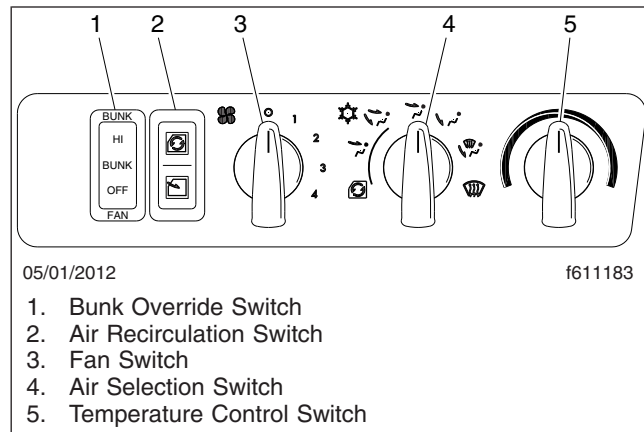

Fig. 5.18, Cab Climate Control Panel

red area for warm air. Turn the switch counterclockwise to the blue area for cool air.

The climate control panel may also be equipped with up to three rocker switches that can control recirculation, air conditioning, and bunk override.

When the recirculation switch is activated, the HVAC system limits the amount of outside air that enters the cab. Activate the recirculation switch to prevent dusty or smoky air from entering the cab.

NOTE: To prevent the buildup of odors and/or oxygen depletion inside the cab, the system switches from full recirculation mode to partial recirculation mode after 20 minutes.

The A/C cools and dehumidifies the air inside the cab. Press the A/C switch to turn the A/C on or off.

Press the bunk override switch to make the cab controls override the settings on the sleeper temperature control panel; the sleeper temperature will mimic the cab settings.

Sleeper Climate Control

The sleeper temperature can be controlled from the sleeper climate control panel or from the cab climate control panel if the bunk override switch is activated. See [Fig. 5.5](#).

The fan switch controls the sleeper temperature fan speed. To increase airflow, turn the switch clockwise to a higher number. To decrease the airflow, turn the switch counterclockwise to a lower number.

The temperature control switch is used to select the desired temperature in the sleeper. Turn the switch

clockwise to the red area for warm air. Turn the switch counterclockwise to the blue area for cool air.

Cancel bunk override mode, if activated, by changing the sleeper fan speed or temperature setting. The system will then operate from the sleeper controls.

Seat Controls

NOTE: See [Chapter 7](#) for detailed information about seat controls and adjustments.

WARNING

Keep hands, tools, and other objects away from the scissor points under the seats. Failure to do so could cause personal injury.

The following is a description of adjustments that can be made to various seats. Not all seats have all of the adjustments listed below. See [Fig. 5.19](#).

- Backrest tilt
- Lumbar support
- Isolator

- Height adjustment
- Bottom cushion angle (fore-and-aft bottom cushion height)
- Fore-and-aft seat slide (seat track adjustment)
- Seat tilt
- Headrest adjustment

Adjustable Steering Column Controls

The adjustable steering column control button is located on the outboard sidewall of the cab. See [Fig. 5.20](#).

After adjusting the seat to the desired ride position, unlock the steering column by pushing and holding the tilt/telescope button down with the outboard foot. Tilt the steering column and the steering wheel telescope function to the desired position. Release the tilt/telescope button to lock the steering wheel and column in place.

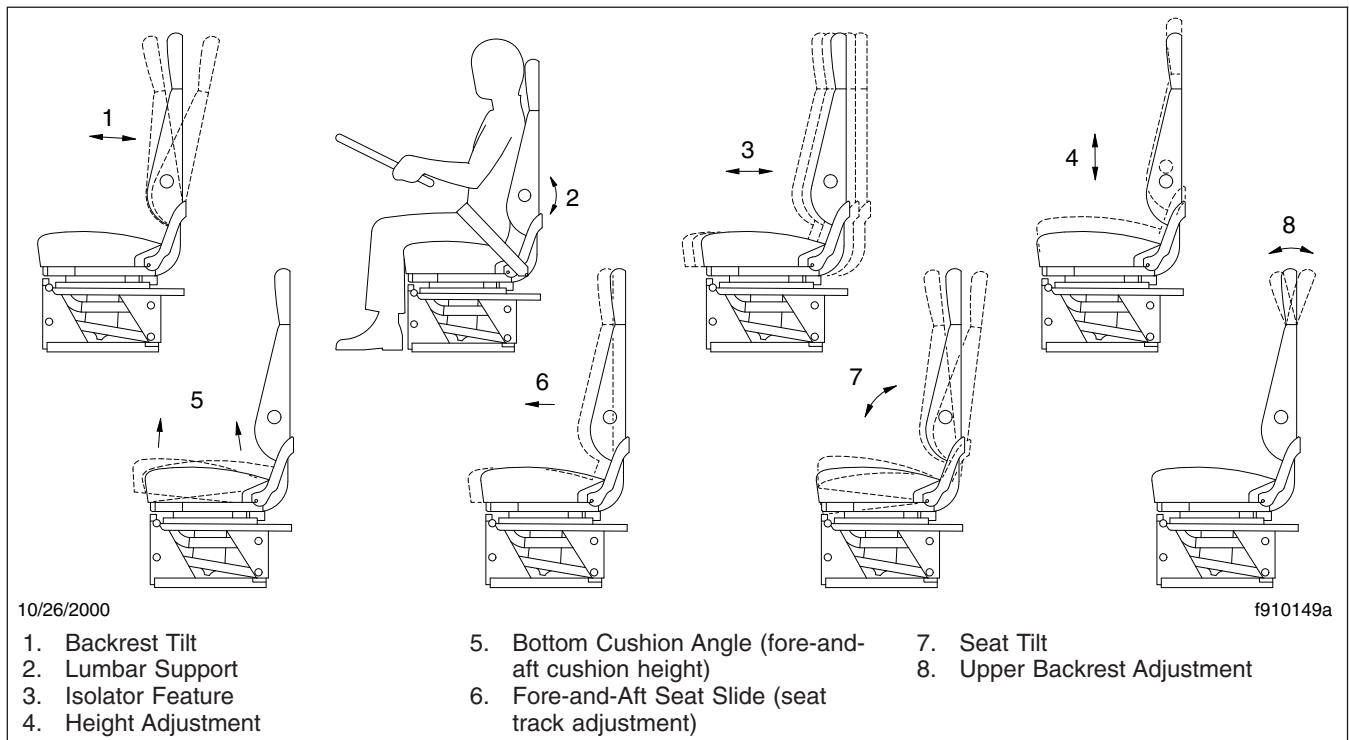

Fig. 5.19, General Seat Adjustments

Driver Controls

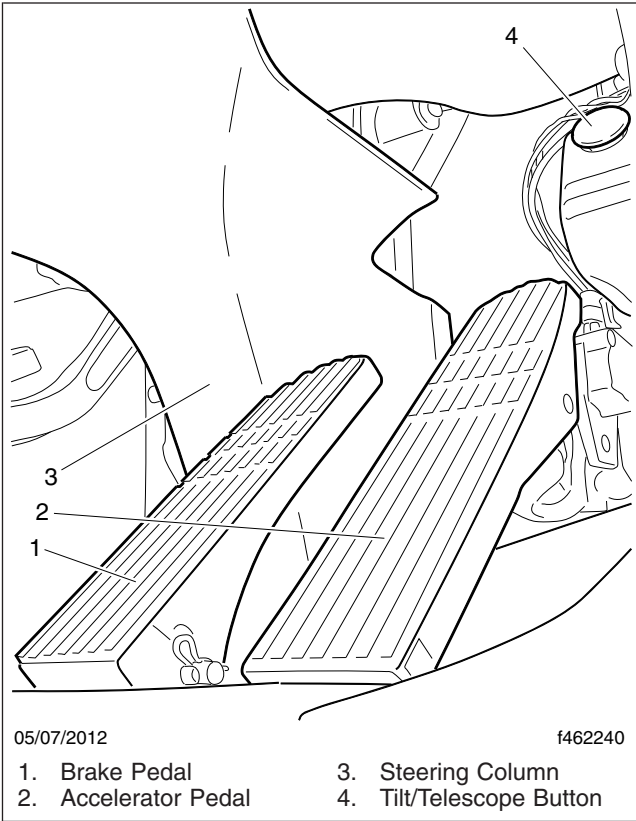

Fig. 5.20, Steering Column Tilt/Telescope Button (RHD shown)

6

Climate Control

Cab Climate Control Panel	6.1
Sleeper Climate Control Panel	6.2

Climate Control

Cab Climate Control Panel

The climate control panel allows the driver to control the heating, ventilating, defrosting, and air conditioning (A/C) functions. See [Fig. 6.1](#). The cab climate control panel has three knobs to control the functions of the cab temperature system:

- fan control knob
- air selection knob
- temperature control knob

The climate control panel may also be equipped with up to three rocker switches to control recirculation, air conditioning, and bunk override.

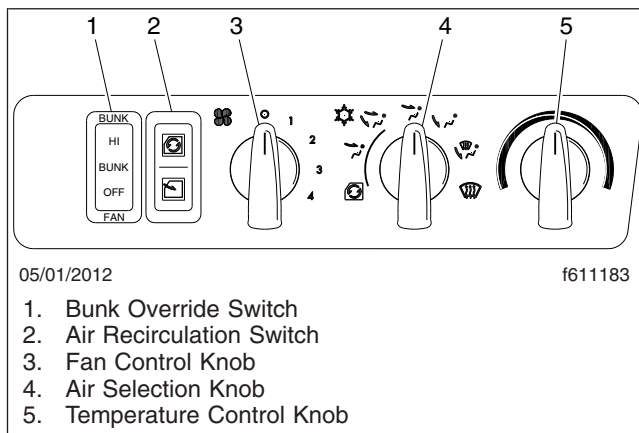

Fig. 6.1, Cab Climate Control Panel

All of the dash-face outlets have adjustable louvers that pivot right and left, and up and down. The outlets can be closed by moving the louvers all the way down. Windshield defrost outlets and the passenger's door window defrost outlet have non-adjustable louvers. The bunk outlet (at the right-hand rear corner of the bunk) has two sets of vertical louvers that operate like the horizontal dash-face louvers.

Fan Control Knob

The fan control knob activates the fan, which forces fresh air or recirculated air through the air outlets. The fan control knob has eight fan speed settings and an OFF position.

To operate the fan knob, turn knob clockwise to increase airflow, or counterclockwise to decrease airflow.

Temperature Control Knob

The temperature control knob is used to select the desired temperature in the cab. Turn the knob counterclockwise for cool air, or clockwise for hot air.

Air Selection Knob

The air selection knob allows the driver to control the flow of air through the face outlets, the floor outlets, the defrost (windshield) outlets, or a combination of these outlets.

- *Air Conditioning Mode:* Cools and dehumidifies the air inside the cab
- *Face Mode:* Directs all airflow through the face or instrument panel outlets.
- *Bi-Level Mode:* Directs the airflow equally to the face outlets and the floor outlets.
- *Floor Mode:* Directs all airflow through the floor outlets.
- *Floor/Defrost Mode:* Directs the airflow equally to the floor outlets and the defrost outlets.
- *Defrost Mode:* Directs all airflow through the defrost outlets.

IMPORTANT: Operate the air conditioner at least five minutes each month, even during cool weather. This helps prevent drying and cracking of tubing seals, reducing refrigerant leaks in the system.

NOTE: Shutting off the heater supply gate valve (if equipped) on the engine limits the ability to control air conditioning temperature in the cab and in the sleeper. With the valve shut off, warm coolant is no longer available from the engine, and the outlet air temperature controls can't be used to change air temperature.

Recirculation Switch

When the recirculation switch is activated, the HVAC system limits the amount of outside air that enters the cab. Activate the recirculation switch to prevent dusty or smoky air from entering the cab. Recirculation mode can also decrease the time required to cool or heat the cab interior during extreme outside temperature conditions. When the recirculation mode

is turned on, the amber indicator on the recirculation switch will illuminate.

The recirculation switch will not work when the mode control switch is in either defog or defrost modes.

IMPORTANT: To prevent the buildup of fumes or odors inside the cab (for example, from smoking) *do not* operate the heater and air conditioning system in recirculation mode for more than 20 minutes.

Bunk Override Switch

The bunk override switch, equipped on sleeper cabs only, allows the driver to control sleeper heat and A/C settings from the cab. Press the bunk override switch to turn the sleeper heat or A/C on. An amber indicator will illuminate when bunk override mode is activated.

Press the bunk override switch again to turn bunk override mode off. Adjusting the sleeper climate controls at any time will also cause the bunk override mode to cancel.

Sleeper Climate Control Panel

An auxiliary heater and air conditioner unit is standard when there is a sleeper compartment. The unit is installed in the right side sleeper baggage compartment and uses the cab's refrigerant liquid system for air conditioner operation. The unit is equipped with a separate evaporator coil, expansion valve, and fan. It is also equipped with its own heater core and water valve, independent of the cab heater. The auxiliary unit's climate control panel is mounted on the right rear wall or the rear overhead storage compartment.

The standard sleeper climate control panel has a fan control knob and a temperature control knob. See [Fig. 6.2](#).

If the bunk override switch has been activated, the override mode can be canceled by changing the sleeper fan speed or temperature setting. The climate control system will then operate from the sleeper controls.

When the climate control unit is set for fresh air, 300 cubic feet per minute of air is provided to the sleeper and stale air is exhausted through a vent in the left rear area of the sleeper. When the system is acti-

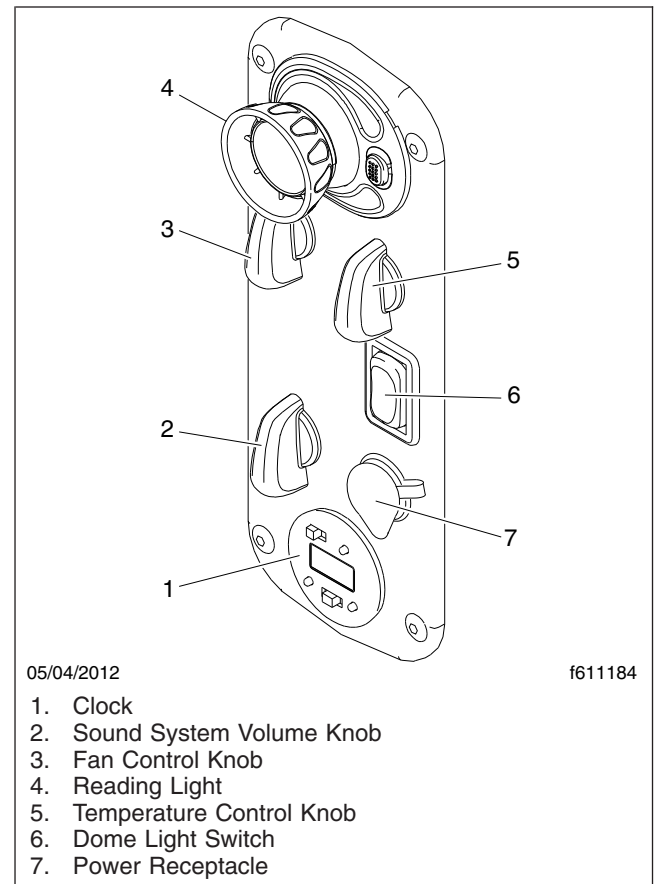

Fig. 6.2, Sleeper Climate Control Panel

vated, fresh air rapidly displaces stale air as the cab pressurizes.

Fan Control Knob

The fan control knob activates the fan, which forces air through the air outlets. The fan control knob has eight fan speeds and an OFF position.

To operate the fan control knob, turn the knob clockwise to increase airflow, or counterclockwise to decrease airflow.

IMPORTANT: To prevent the buildup of fumes or odors inside the sleeper (for example, from smoking) *do not* operate the heater and air conditioning system in recirculation mode for more than 20 minutes.

NOTE: When the cab air conditioner (A/C) is on, the sleeper fan will operate at low speed even if

Climate Control

the sleeper fan knob is turned to OFF. This is necessary to protect the evaporator in the sleeper heater and air conditioner system from freezing. At lower fan speed settings, a slight increase in airflow levels may appear at times, as the control acts to regulate the evaporator temperature.

Temperature Control Knob

The temperature control knob is used to select the desired temperature in the sleeper. Turn the knob counterclockwise for cool air, or clockwise for hot air.

7

Seats and Restraints

Seats, General Information	7.1
Freightliner High-Back Seat	7.2
Bostrom Seat	7.3
EzyRider® Seat	7.4
National Seat	7.5
ABTS Seat	7.5
Seat Belts and Tether Belts	7.6
Sleeper Compartment Restraints	7.9
Steering Wheel Air Bag	7.10

Seats and Restraints

Seats, General Information

Unless otherwise noted, all seat adjustments should be made while seated and before the engine is started.

Due to the high degree of adjustability of mid- and high-back air suspension seats, it is possible to combine the seat back recline adjustment and the seat slide adjustment so that the seat back contacts the back wall. Use care when adjusting the seat to prevent damage to the seat and the cab interior.

WARNING

Keep hands, tools, and other objects away from the scissor points under the seats. Failure to do so could cause personal injury.

The following is a description of adjustments that can be made to various Argosy seats. Not all seats have all of the adjustments listed below. See [Fig. 7.1](#).

- *Backrest Tilt* enables the backrest to pivot forward or backward.

- *Lumbar Support* changes the shape of the backrest to give more or less support to the occupant's lumbar (lower back) area. This adjustment is either mechanical or air controlled, depending on the seat model.
- *Fore/Aft Isolator* feature reduces the amount of road shock by isolating the occupant from the motion of the vehicle, and allowing the upper seat to move in a simple pendulum motion. A lockout feature is used whenever the isolator is not desired.
- *Height Adjustment* moves the entire seat up or down. The adjustment is either manually- or air-controlled, depending on the seat model.
- *Bottom Cushion Angle (fore-and-aft bottom cushion height)* enables the occupant to raise or lower the front or back of the bottom cushion. This adjustment is easier to perform when all weight is removed from the seat.

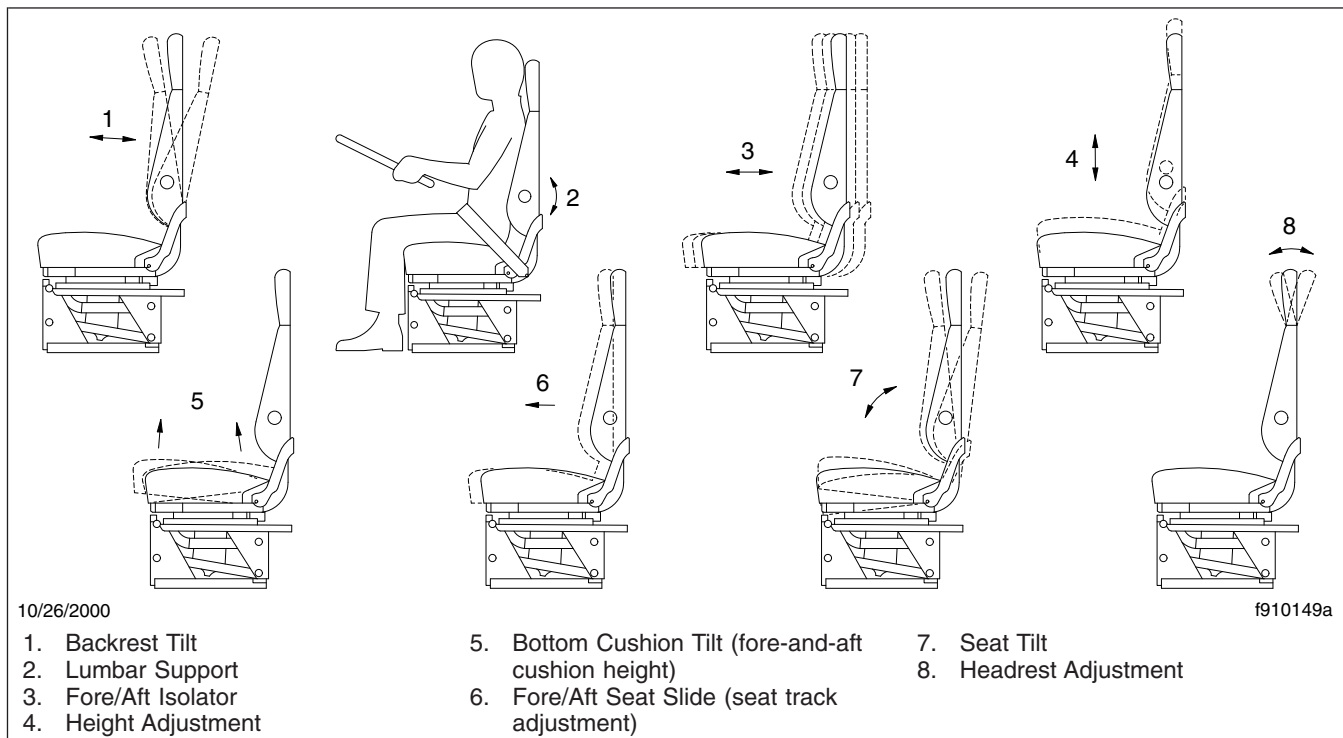

Fig. 7.1, General Seat Adjustments

- *Fore/Aft Seat Slide (seat track adjustment)* moves the entire seat forward or backward on its track.
- *Seat Tilt* allows the seat assembly (back and bottom cushions) to tilt forward or backward.
- *Headrest Adjustment* changes the angle of the upper part of the backrest to provide head and upper back support.

Freightliner High-Back Seat

See [Fig. 7.2](#) for seat adjustment controls. Not all models of the seat have all the adjustments listed below.

Backrest Tilt

To tilt the backrest, lean forward slightly to remove pressure from the cushion, then turn the knob forward or rearward to achieve the desired position.

Lumbar Support

To adjust the lumbar support, use the lumbar support switches on the side of the seat.

Height Adjustment

To raise or lower the height of the seat, use the height adjustment switch on the side of the seat.

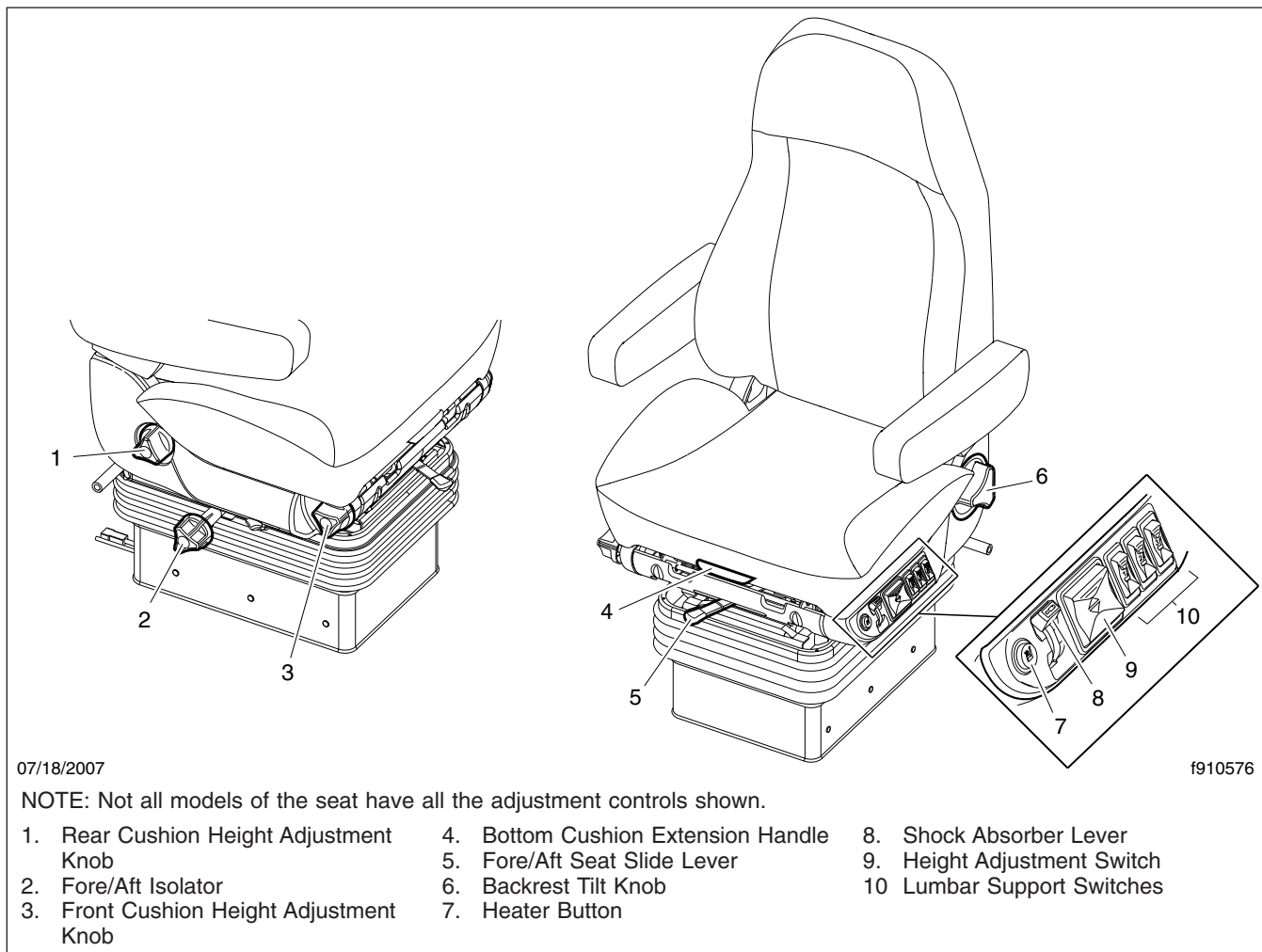

Fig. 7.2, Freightliner High-Back Seat

Seats and Restraints

Bottom Cushion Extension

To adjust the fore-and-aft position of the seat cushion, remove your weight from the seat, then lift up and pull forward on the cushion adjustment handle. To return the cushion to the aft position, lift up and push rearward.

Fore/Aft Seat Slide

To adjust the fore-and-aft position of the entire seat, move the fore-and-aft seat adjustment lever to the left and slide the seat forward or backward to the desired position. Move the lever back to its original position to lock the seat in place.

Fore/Aft Isolator

To engage the isolator, turn the isolator knob rearward to the unlocked position. Turn the isolator knob forward to the locked position when the isolator feature is not desired.

Shock Absorber

To adjust the amount of damping the shock absorber provides, move the lever up to increase damping; move the lever down to decrease damping.

Front Cushion Height

To adjust the height of the front of the cushion, remove your weight from the seat, then turn the adjustment knob toward the front of the seat (clockwise) to increase cushion height. To lower the cushion height, turn the adjustment knob toward the rear of the seat (counterclockwise).

Rear Cushion Height

To adjust the height of the rear of the seat cushion, remove your weight from the seat and turn the rear cushion adjustment knob to one of three positions.

Heater

To turn on the heat option, press the button. To turn off the heat option, press the button again. If the vehicle has Optimized Idle, seat heating will not operate with the key in accessory mode. Optimized Idle may also turn seat heating off to reduce stress on the batteries.

Bostrom Seat

See [Fig. 7.3](#) for Bostrom seat adjustment controls.

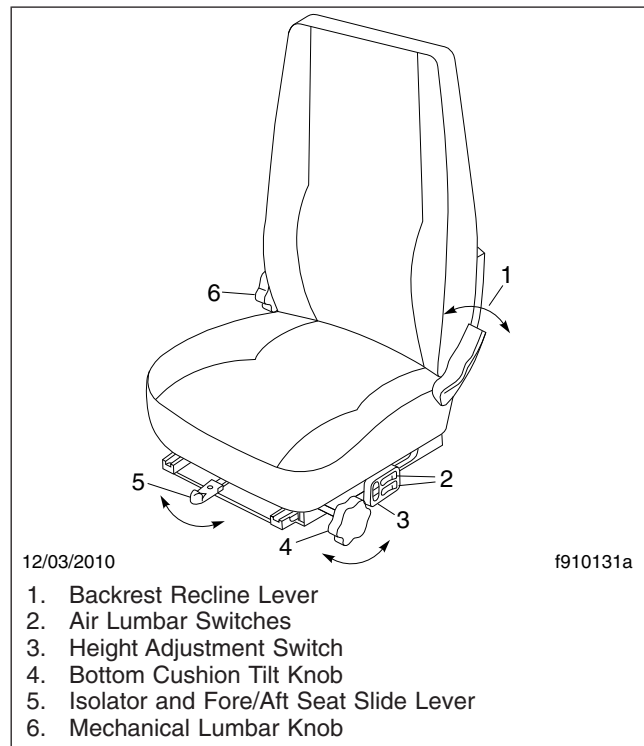

Fig. 7.3, Bostrom Seat Adjustment Controls

Backrest Recline

To recline the backrest, lean forward slightly to remove pressure from the cushion and hold the backrest recline lever rearward. Lean forward or backward slowly to the desired position and release the lever to lock the backrest in place.

Bottom Cushion Tilt

To adjust the bottom cushion tilt, rotate the bottom cushion tilt knob to increase or decrease tilt.

Fore-and-Aft Seat Slide

To adjust the fore-and-aft position of the entire seat, hold the fore-and-aft adjustment lever to the left and slide the seat forward or backward to the desired position.

Height Adjustment

To raise the seat, press the upper portion of the height adjustment switch. To lower the seat, press the lower portion of the switch.

Isolator

To engage the isolator, put the isolator lever in the center position. Lock out the isolator by moving the lever to the right.

Lumbar Support

To increase lumbar support on standard models, rotate the mechanical lumbar knob forward. To decrease lumbar support, rotate the knob rearward.

To increase lumbar support on optional models, press the plus sign on the air lumbar switch. To decrease lumbar support, press the minus sign on the switch.

EzyRider® Seat

For EzyRider seat adjustment controls, see [Fig. 7.4](#).

Armrest Angle (optional armrests)

To adjust the vertical angle of the armrest, turn the adjustment knob on the underside of the armrest.

Backrest Recline

To recline the backrest, raise the backrest recline lever and lean forward or backward. Release the lever to lock the cushion in place.

Bottom Cushion Angle

To adjust the bottom cushion angle, pull the bottom cushion up and forward or down and back. The bottom cushion angle is controlled by the guides on each side of the seat.

Fore-and-Aft Slide Adjustment

To adjust the fore-and-aft position of the entire seat, lift the bar and slide the seat to the desired position.

Height Adjustment

To raise or lower the seat, use the height adjustment switch on the side of the seat.

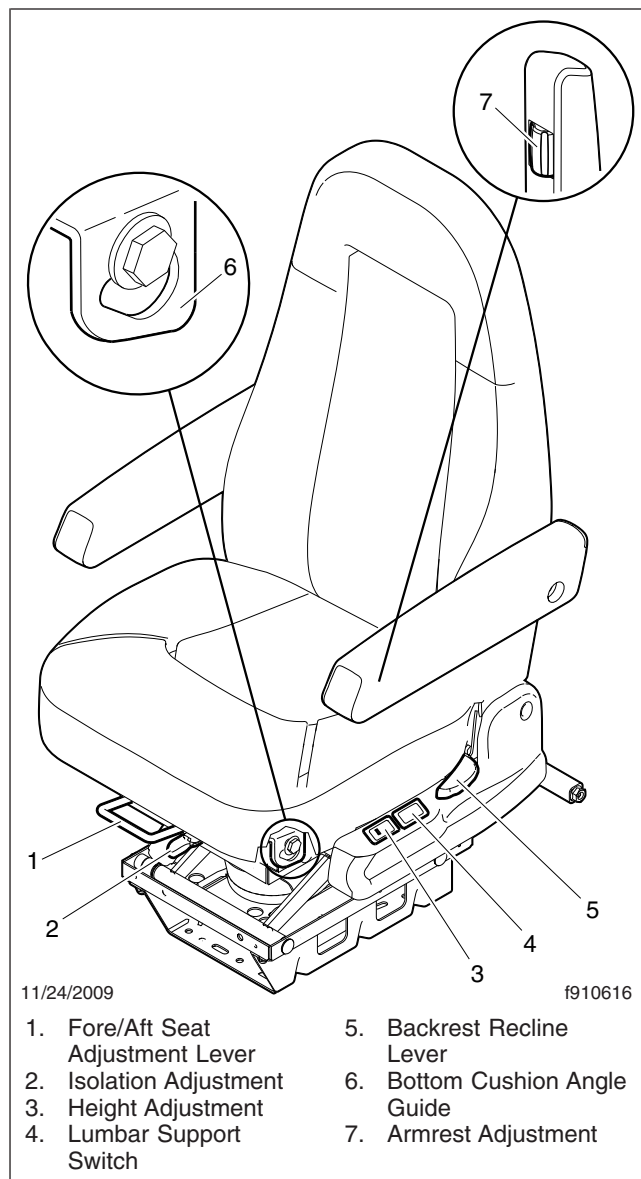

Fig. 7.4, EzyRider Seat Adjustment Controls

Isolator

To adjust the isolator, move to the switch left to allow insulation; move it to the right to lock the isolator.

Seats and Restraints

Lumbar Support

To adjust the amount of support for your lower back, push the front of the switch to inflate the lower lumbar bag, push the rear of the switch to deflate the bag.

National Seat

See **Fig. 7.5** for National seat adjustment controls.

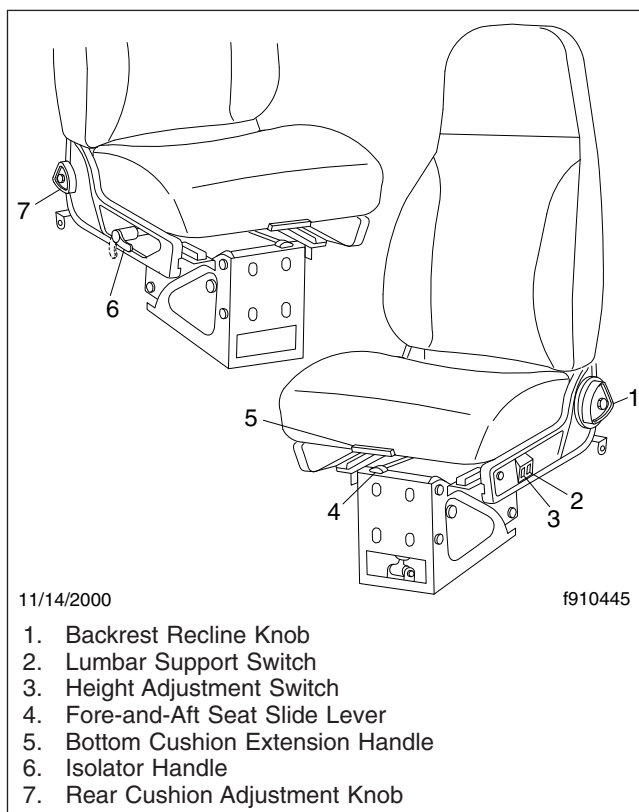

Fig. 7.5, National 2000 Series Seat Adjustment Controls

Backrest Recline

To recline the backrest, turn the backrest recline knob until the desired position is reached.

Bottom Cushion Extension

To adjust the bottom cushion, lift the bottom cushion adjustment handle and pull forward or push back to the desired setting.

Fore-and-Aft Seat Slide

To adjust the fore-and-aft position of the entire seat, move the fore-and-aft seat adjustment lever to the left and slide the seat forward or backward to the desired position. Move the lever back to its original position to lock the seat in place.

Height Adjustment

To raise or lower the height of the seat, use the height adjustment switch on the side of the seat.

Isolator

To engage the isolator, turn the isolator lever to the horizontal position. Lock out the isolator by turning the isolator lever down.

Lumbar Support

To adjust the lumbar support, use the lumbar support switch on the side of the seat.

Rear Cushion Adjustment

To adjust the height of the rear of the seat cushion, remove your weight from the seat and turn the rear cushion adjustment knob to one of three positions.

ABTS Seat

See **Fig. 7.6** for ABTS (all-belts-to-seat) seat adjustment controls.

Cushion Extension Adjustment

Move the cushion extension adjustment lever to the left and move the seat cushion to the desired position.

Track Adjustment

To adjust the fore-and-aft position of the entire seat, lift the track adjustment handle and slide the seat to the desired position.

Isolator

Pull up the isolator control handle to lock out the isolation movement.

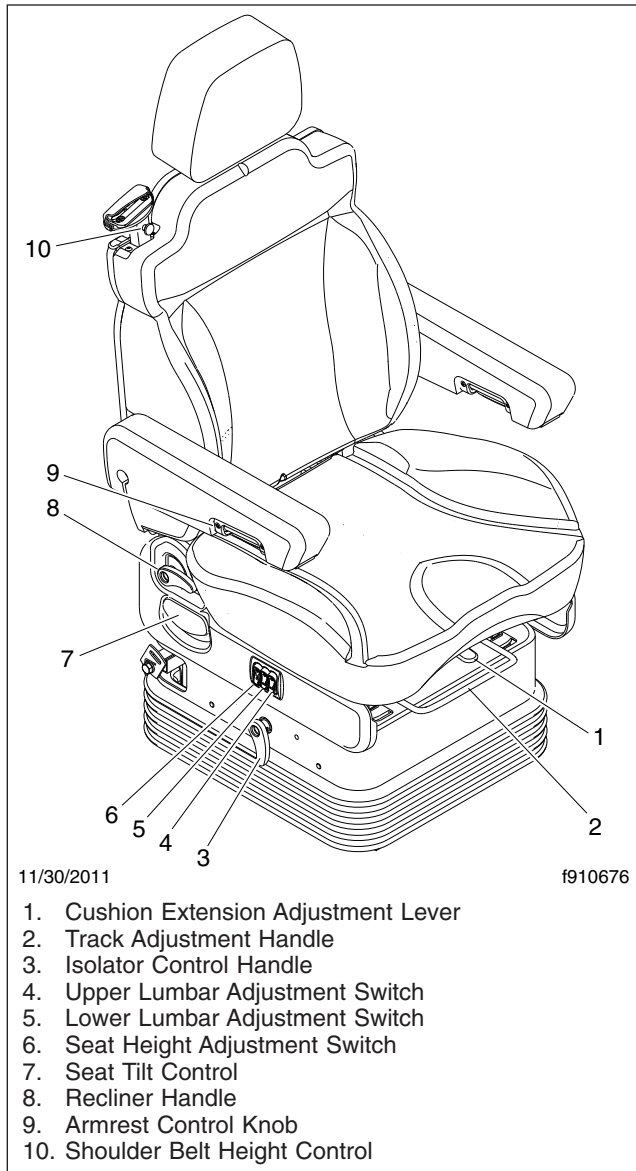

Fig. 7.6, ABTS Seat Adjustment Controls

Lumbar Adjustment

Push the middle rocker switch to adjust the lower lumbar bag. Push the forward switch to adjust the upper lumbar bag.

Seat Height Adjustment

Push the seat height adjustment switch to raise or lower the seat suspension.

Seat Tilt Control

Set the seat tilt control to one of the five positions to set cushion rake adjustment.

Backrest Adjustment

To tilt the backrest backward, pull up on the recliner handle while leaning backward. To tilt the backrest forward, pull up on the recliner handle while leaning forward.

Armrest Adjustment

Rotate the control knob, located on the underside of the armrest, to set the desired angle of the armrest.

Shoulder Belt Height Control

Adjust the shoulder belt height. The height can be adjusted vertically by 3 inches (75 mm).

Seat Belts and Tether Belts

Seat belt assemblies are designed to secure persons in the vehicle to help reduce the chance of injury or the amount of injury resulting from accidents or sudden stops. For this reason, Daimler Trucks North America LLC (DTNA) urges that the driver and *all* passengers, regardless of age or physical condition, use seat belts when riding in the vehicle.



Always use the vehicle's seat belt system when operating the vehicle. Failure to do so can result in severe personal injury or death.

Seat belt assemblies in DTNA vehicles meet Federal Motor Vehicle Safety Standard 209, "Type 1" and "Type 2" requirements.

When transporting a child, always use a child restraint system or the vehicle seat belts as appropriate. To determine whether a child restraint system is required, review and comply with applicable state and local laws. Any child restraint used must comply with Federal Motor Vehicle Safety Standard 213, "Child Restraint Systems." When providing a child restraint system, always carefully read and follow all instructions pertaining to installation and usage for the child. Make certain the child remains in the restraint system at all times when the vehicle is in motion.

Seats and Restraints

In addition to seat belt assemblies, tether belts are installed on suspension-type seats. Tether belts help secure the seat to the floor and are intended to restrain the seat and seat belt in case of an accident or sudden stop.

IMPORTANT: Seat belts have a finite life which may be much shorter than the life of the vehicle. Regular inspections and replacement as needed are the only assurance of adequate seat belt security over the life of the vehicle.

Seat Belt Inspection

! WARNING

Inspect and maintain seat belts. When any part of a seat belt system needs replacement, the entire seat belt must be replaced, both retractor and buckle side. Any time a vehicle is involved in an accident, and the seat belt system was in use, the entire vehicle seat belt system must be replaced before operating the vehicle. Do not attempt to modify the seat belt system; doing so could change the effectiveness of the system. Failure to replace worn or damaged seat belts, or making any modifications to the system, may result in personal injury or death.

Inspect the seat belts and tether belts (if so equipped).

1. Check the web for fraying, cuts, extreme dirt and dust, or for severe fading from exposure to sunlight, especially near the buckle latch plate and in the D-loop guide area.
2. Check operation of the buckle, latch, Komfort Latch or Sliding Komfort Latch (if equipped), web retractor, and upper seat belt mount on the door pillar. Check all visible components for wear or damage.
3. Check the seat belt and tether belt connection points and tighten any that are loose.

Seat Belt Operation

Three-Point Seat Belt With Komfort Latch

NOTE: For vehicles not equipped with the Komfort Latch, see the seat belt operation under the heading "Three-Point Seat Belt."

! WARNING

Wear three-point seat belts only as described below. Three-point seat belts are designed to be worn by one person at a time. In case of an accident or sudden stop, personal injury or death could result from misuse.

Fasten the seat belts before driving. Fastening a three-point seat belt while driving creates a hazard.

1. Slowly pull the link end of the three-point seat belt out of the retractor and pull it across your lap (from outboard to inboard) far enough to engage the buckle. If the retractor locks too soon, allow the belt to retract slightly, then slowly pull it out again.
2. Fasten the three-point seat belt by pushing the link into the buckle until it latches (**Fig. 7.7**). Give the belt a tug at the buckle. If the buckle unlatches, repeat this step. If the problem continues, replace the three-point seat belt.

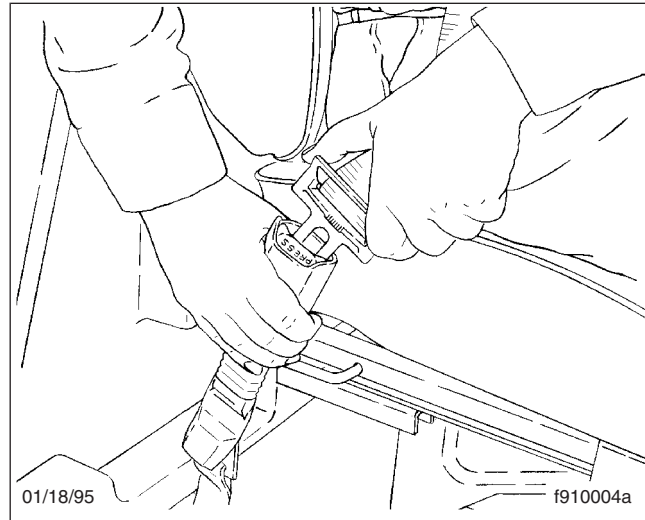

Fig. 7.7, Fastening the Three-Point Belt

3. Position the shoulder strap diagonally across your chest with the adjustable D-loop bracket (if equipped). The shoulder strap must be centered on your shoulder and chest, away from your face and neck. See **Fig. 7.8**. If desired, engage the Komfort Latch as follows.

Pull on the shoulder strap to lessen the pressure of the strap on your shoulder and chest. Allow no

Seats and Restraints

more than one inch (2.5 cm) of slack between your chest and the shoulder harness. More slack can significantly reduce the seat belt's effectiveness in an accident or a sudden stop. While holding the belt slack, press the Komfort Latch lever up, clamping the seat belt webbing (Fig. 7.9 and Fig. 7.10).

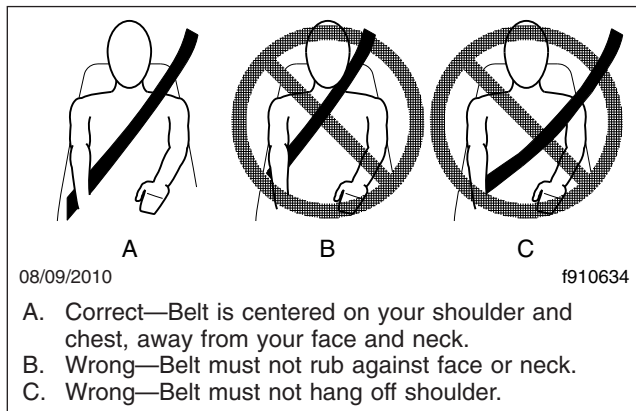

Fig. 7.8, Proper Shoulder Strap Fit

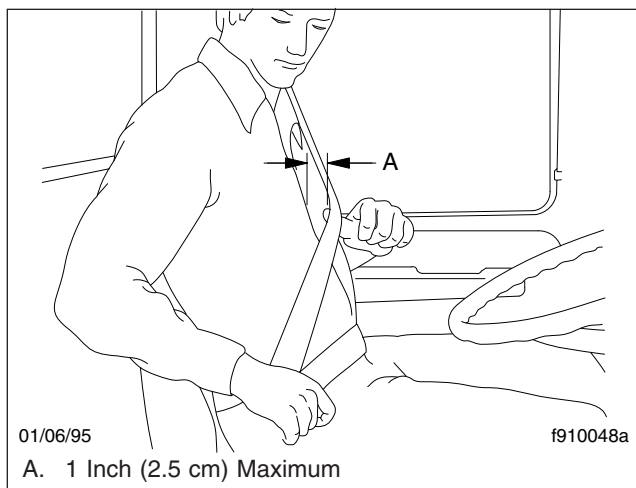

Fig. 7.9, Adjusting Shoulder Harness Clearance

- To unbuckle the three-point seat belt, push the button on the buckle as shown in Fig. 7.11. If the Komfort Latch was used, release it by giving the shoulder belt a quick tug. If you lean forward against the shoulder belt, the Komfort Latch will automatically release, and will need to be reset.

NOTE: The Komfort Latch does not have to be released in an emergency situation. The Komfort Latch will release by itself under rough road

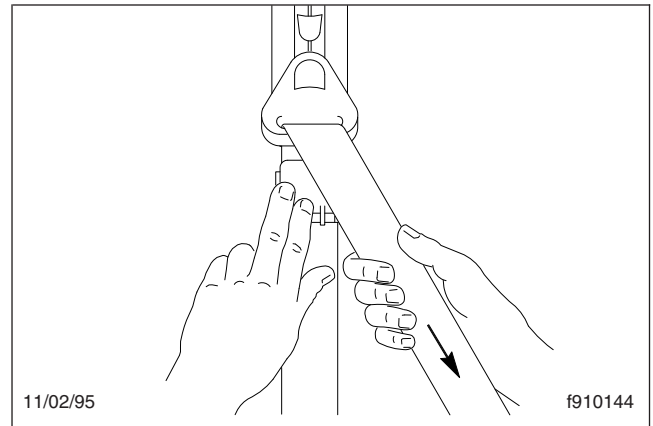

Fig. 7.10, Locking Komfort Latch

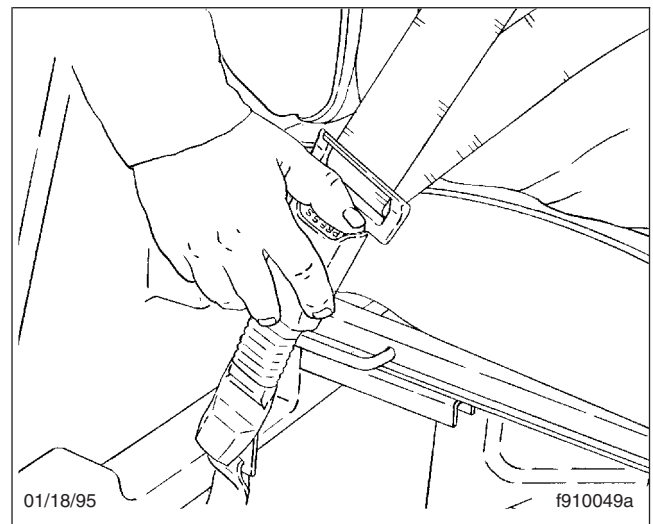

Fig. 7.11, Releasing the Three-Point Seat Belt

or other abnormal conditions. Make sure the three-point seat belt is completely retracted when it is not in use.

Three-Point Seat Belt

NOTE: For vehicles equipped with the Komfort Latch, see the seat belt operation under the heading "Three-Point Seat Belt With Komfort Latch."

WARNING

Wear three-point seat belts only as described below. Three-point seat belts are designed to be

Seats and Restraints

worn by one person at a time. In case of an accident or sudden stop, personal injury or death could result from misuse.

Fasten the seat belts before driving. Fastening a three-point seat belt while driving creates a hazard.

1. Slowly pull the link end of the three-point seat belt out of the retractor and pull it across your lap (from outboard to inboard) far enough to engage the buckle. If the retractor locks too soon, allow the belt to retract slightly, then slowly pull it out again.
2. Fasten the three-point seat belt by pushing the latch into the buckle. Listen for an audible click. See [Fig. 7.7](#).
3. Tug on the seat belt to make sure it is securely fastened. If the buckle unlatches, repeat this step. If the problem continues, replace the three-point seat belt.
4. Snug the seat belt to your waist.
5. Position the shoulder strap diagonally across your chest with the adjustable D-loop bracket (if equipped). The shoulder strap must be centered on your shoulder and chest, away from your face and neck. See [Fig. 7.8](#).
6. To unbuckle the three-point seat belt, press the release button on the buckle; see [Fig. 7.11](#).

NOTE: Make sure the three-point seat belt is completely retracted when it is not in use.

Sleeper Compartment Restraints

WARNING

Do not use the sleeper compartment while the vehicle is in motion unless a bunk restraint is installed and used. Not using the bunk restraint increases the chance of injury, or the degree of injury, from accidents or sudden stops to all occupants of the vehicle.

On vehicles equipped with a sleeper compartment, bunk restraints should be used whenever the sleeper compartment is occupied and the vehicle is moving. Restraints are designed to lessen the chance of in-

jury or the amount of injury resulting from accidents or sudden stops.

Bunk Restraint Adjustment

1. Make sure the belt is attached to the bunk support and sleeper wall.
2. To lengthen the belt, tip the link end downward and pull the link until it connects with the buckle.
3. After the belt is connected, shorten it by pulling on the loose end until the belt is snug, but comfortable. Be sure the belts are not twisted. See [Fig. 7.12](#).

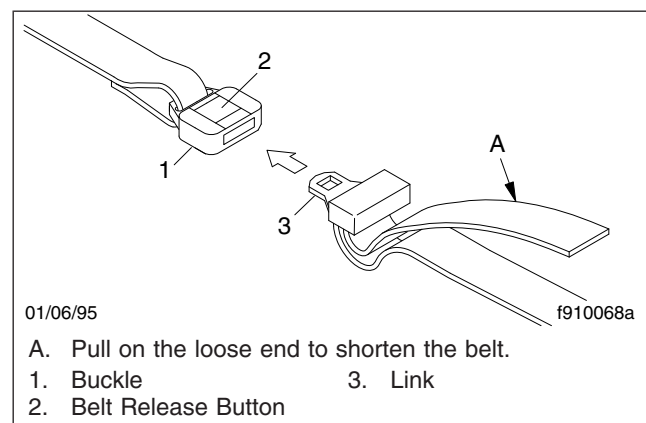

Fig. 7.12, Bunk Restraint Adjustment

Bunk Restraint Operation

1. Starting at the foot of the bunk, pull the link end of the belt up far enough to engage the buckle. See [Fig. 7.13](#).
2. Fasten the belt by pushing the link end into the buckle until it latches. Make sure that the belt is not twisted. Check the engagement by trying to pull the link out of the buckle. If they come apart, repeat this step. If the problem continues, replace the belt. Repeat steps 1 and 2 for the other two belts located in the middle and upper portion of the bunk to lock the restraint in place.
3. To release the bunk restraint, push the release button on the buckle at the head of the bunk and pull the link from the buckle.

Repeat this step for the other two buckles to completely release the bunk restraint.

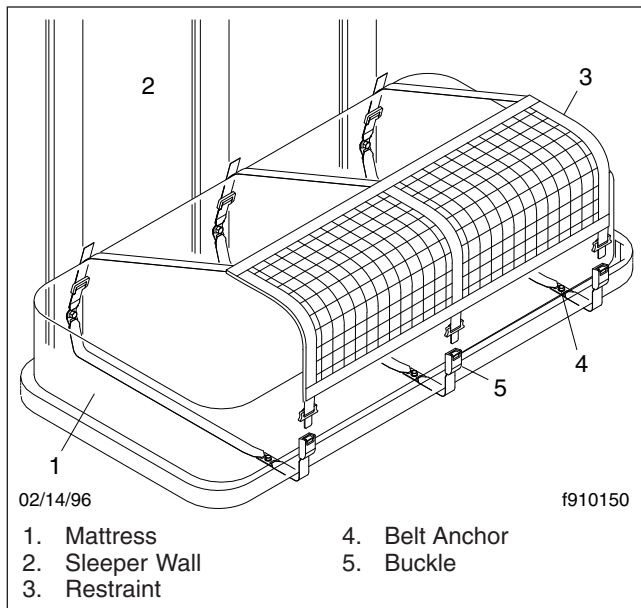

Fig. 7.13, Bunk Restraint

Steering Wheel Air Bag

Operation

NOTE: Only vehicles with the letters "SRS" molded into the steering wheel center pad are equipped with a steering wheel air bag.

The air bag, when used with seat belts, provides additional protection to the driver in severe frontal collisions. Steering wheel air bags are designed to inflate only in severe frontal collisions. The driver and the passenger should always wear seat belts. The steering wheel air bag will activate during a collision even if the seat belts are not fastened, but the system is designed to provide protection to the occupant only when the seat belts are fastened.

WARNING

Keep all heavy objects in the cab secured. Do not place objects on the steering wheel or between you and the steering wheel. Any such objects may cause harm during an accident. Keep your hands on the sides and lower portion of the steering wheel. Failure to follow these instructions may result in death or personal injury.

For maximum protection in a collision, always be in a normal seated position with your back against the

seat back and your head upright. Fasten your seat belt and ensure that it is properly positioned on your body as described under the "Seat Belt Operation" heading. Since the air bag inflates with considerable speed and force, a proper seat position will help keep you a safe distance from the inflating air bag.

Inspection and Service

WARNING

Do not attempt to service or modify the air bag system. Unintentional or improper air bag deployment could cause severe bodily injury or death. Contact an authorized Freightliner service facility for all service and maintenance.

The air bag system contains components that use combustible chemicals. Do not cut, drill, braise, solder, weld, strike, or probe the air bag components. Keep all liquids and chemicals away from air bag components.

The surface of the deployed air bag may contain small amounts of sodium hydroxide (which is a by-product of the gas generant combustion) and metallic sodium. Sodium hydroxide may be irritating to the skin and eyes. Immediately wash your hands and exposed skin areas with a mild soap and water. Flush your eyes immediately if exposed to sodium hydroxide.

The operational readiness of the air bag system is indicated by the supplemental restraint system (SRS) indicator on the dash. The SRS indicator illuminates for several seconds when the ignition is turned on, and then it goes off. The indicator will remain on if there is a problem with the air bag system. The vehicle should be serviced if the SRS indicator does not illuminate when the ignition is turned on, or if the SRS indicator remains on.

The air bag module may contain perchlorate material; for information, see www.dtsc.ca.gov/hazardouswaste/perchlorate. Special handling may apply; follow appropriate rules and regulations when disposing of materials.

For all service and maintenance, contact an authorized Freightliner service facility.

8

Cab and Sleeper Features

Windows	8.1
Mirrors	8.1
Cab Amenities	8.1
Sleeper Amenities	8.2

Cab and Sleeper Features

Windows

The windows in both doors operate manually or electrically (if so equipped). For manual windows, use the crank handle installed on the door to raise or lower a door window.

For electric windows, press the upper half of the switch to raise the window. To lower the window, press the lower half of the switch. See [Fig. 8.1](#).

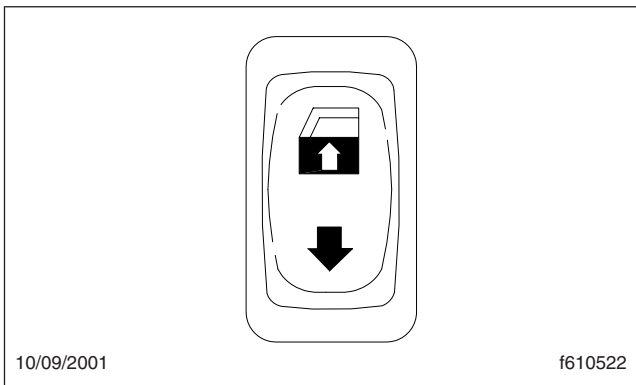

Fig. 8.1, Power Window Switch

Mirrors

The standard outside mirrors are mounted on the door frame. The power mirrors are controlled with a left-hand or right-hand mirror selector switch, and a directional switch. Select the left mirror, or the right mirror using the corresponding arrow selection on the mirror selector switch. The mirror can then be adjusted by pressing the arrows on the 4-way directional switch.

Mirrors may be equipped with an optional heater to keep them clear of fog, frost, and ice. To heat the mirrors, press the upper part of the mirror heat switch on the dash. See [Fig. 8.2](#).

Cab Amenities

Argosy vehicles are available with many optional features. The following are some of those options.

Center Dash Panel

The cab is equipped with two cup holders and three storage trays molded into the center dash.

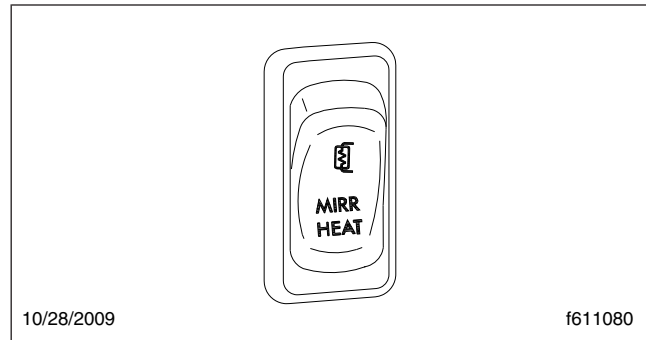

Fig. 8.2, Mirror Heat Switch

A power outlet that supplies 12V power for accessories and an ashtray/coin holder are located below the cup holders.

Lighting

See [Chapter 5](#) for detailed information regarding lighting controls.

Radio and CB

The radio and CB are typically installed in the overhead console. An optional hot mount may be installed on the dash for fleet CB radios.

Storage Areas

Vehicles may have two glove boxes and three molded storage bins located in the overhead console assembly. See [Fig. 8.3](#). Optionally, a citizen's band (C/B) radio may be installed in place of the driver-side glove box. Storage pockets are also molded into the lower portion of the driver and passenger doors.

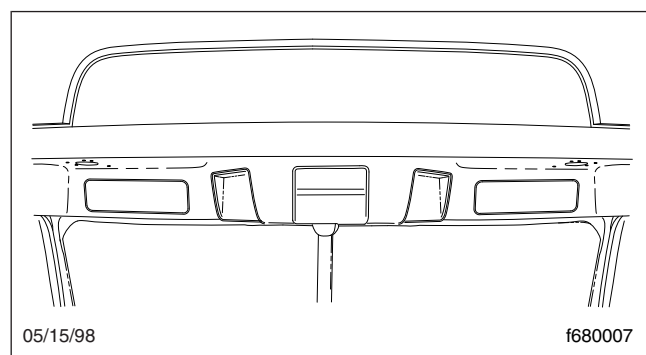

Fig. 8.3, Overhead Storage

Sleeper Amenities

Argosy sleepers are available with many optional features. The following are some of those options.

Baggage Compartment Doors

The baggage compartment doors are intended as a convenient means to stow or remove items under the bunk. The baggage compartment doors can be opened using the pull cable located near the aft edge of the cab door opening on the sidewall behind the seat.

IMPORTANT: Some baggage compartment doors are two-stage latching. When closing the two-stage latching doors, ensure that they are completely latched to prevent wind noise and water intrusion.

Bunk Latches

To move the lower or upper sleeper bunk (if equipped), disengage the latch at the front of the lower bunk, or the latches on both sides of the upper bunk. Lock the bunks into operating position, down for the lower bunk and up or down for the upper bunk, by engaging both the primary and secondary latches.

Lighting

See [Chapter 5](#) for detailed information regarding lighting controls.

Power Outlets

Power outlets are located underneath the lower bunk.

Vents

To open any sleeper compartment vent, push the vent handle outward and forward. To close the vent, pull in and back on the front edge of the handle. Use care to avoid pinching of fingers.

9

Engine Starting, Operation, and Shutdown

Engine Starting	9.1
Engine Operation	9.2
Engine Shutdown	9.3

Engine Starting, Operation, and Shutdown

Engine Starting

This engine chapter is to serve as a guide for best practices only. Each engine model may have operating characteristics that are unique to that particular engine, and will be documented in the engine manufacturer's literature. Always refer to specific instructions and recommendations from the engine manufacturer.

NOTE: Before starting the engine, read **Chapter 4, Instruments**, and **Chapter 5, Driver Controls**. Read the engine manufacturer's operating instructions before starting the engine.

WARNING

Never pour fuel or other flammable liquid into the air inlet opening in the air intake in an attempt to start the vehicle. This could result in a flash fire causing serious personal injury or property damage.

IMPORTANT: The starter **can not** be used for priming the fuel system. If the fuel/water separator filter is replaced, and the fuel system needs to be primed, see the engine manufacturer's operating instructions.

1. Before engine start-up, complete the pre- and post-trip inspections and maintenance procedures in **Chapter 23**.
2. Set the parking brake.
3. Place the transmission in neutral. On vehicles with manual transmissions, fully depress the clutch pedal.

NOTE: Depending on local jurisdictional emissions regulations, vehicles may not be equipped with the WAIT TO START lamp.

4. Turn the ignition switch to the ON position and allow the gauge sweep to complete. See **Fig. 9.1**. The audible alert will sound for approximately four seconds.

During cold conditions, the WAIT TO START lamp may illuminate. Wait until the lamp goes out before turning the ignition switch to START.

NOTE: The length of time the WAIT TO START lamp remains illuminated depends on the ambi-

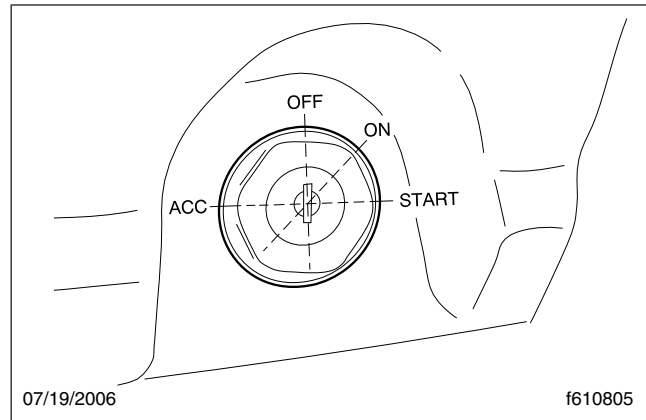

Fig. 9.1, Ignition Switch

ent temperature. The lower the ambient temperature, the longer the lamp will be illuminated.

5. Once the gauge sweep has completed, turn the ignition key to the START position. Release the key the moment the engine starts.

NOTICE

Do not rev the engine if the oil pressure gauge indicates no oil pressure. Shut down the engine if oil pressure does not build within approximately 10 seconds. Check to determine the cause of the problem. Operating the engine with no oil pressure will damage the engine.

6. It is not necessary to idle the engine before engaging or starting the operation, but load should be applied gradually during the warm-up period until the oil temperature reaches 140°F (60°C).
7. Apply load gradually during the warm-up period.

NOTICE

If the oil pressure gauge indicates no oil pressure, shut down the engine within approximately ten seconds to avoid engine damage.

8. Check the oil pressure gauge for any drop in pressure or mechanical malfunction in the lubricating oil system. Minimum oil pressure at idle is 7 psi (48 kPa).

Engine Starting, Operation, and Shutdown

Cold-Weather Starting

See the engine manufacturer's operation manual for starting aids that are approved for specific engines.

Starting After Extended Shutdown

Before engine start-up, complete the engine pretrip inspections in [Chapter 23](#).

NOTICE

Failure to eliminate water-diluted lubricating oil may lead to serious engine damage at startup.

An engine in storage for an extended period of time (over winter, for example) may accumulate water in the oil pan through normal condensation of moisture on the internal surfaces of the engine. Oil diluted by water cannot provide adequate bearing protection at start-up. For this reason, change the engine oil and filters after extended storage.

Engine Operation

Safety and Environmental Considerations

WARNING

Do not operate the engine in an area where flammable vapors such as gasoline or diesel fumes are present. Shut off the engine when in an area where flammable liquids or gases are being handled. Failure to observe these precautions could result in serious injury or death.

Once an engine is placed in service, the responsibility for meeting both state and local regulations is with the owner/operator.

IMPORTANT: Depending upon local jurisdictional emissions guidelines, the vehicle may not be equipped with an emissions aftertreatment system (ATS). Adequate maintenance of the engine and the diesel particulate filter (DPF) are the responsibility of the owner/operator, and are essential to keep the emission levels low. Good operating practices, regular maintenance, and correct adjustments are factors that will help keep emissions within the regulations.

NOTICE

It is extremely important that the following guidelines be followed for engines that are equipped with an ATS, or damage may occur to the after-treatment device, and the warranty may be compromised.

- Use ultralow-sulfur diesel with 15 ppm sulfur content or less.
- Do not use fuel blended with used engine lube oil or kerosene.
- Use only engine lube oil with a sulfated ash level less than 1.0 wt%.

The driver should be familiar with the vehicle warning system in order to bring the vehicle to a safe stop if the engine malfunctions. If the driver doesn't understand how the warning system works, an engine shutdown could occur, causing a safety hazard. See [Chapter 10](#) for more information.

Engine Break-In

Each engine must pass a full-load operating test on a dynamometer before shipment, thereby eliminating the need for a break-in. Before running the engine for the first time, follow the instructions in the manufacturer's engine operation manual.

Normal Operation

WARNING

Do not operate the engine in an area where flammable vapors such as gasoline or diesel fumes are present. Shut off the engine when in an area where flammable liquids or gases are being handled. Failure to observe these precautions could result in serious injury or death.

Every engine has an operating range in which it performs most efficiently. The operating range extends from maximum torque rpm at the low end, to engine rated speed at the high end. Most engines deliver best fuel economy when operated in the low- and mid-speed segments of the efficiency range and produce maximum horsepower at rated speed, which is also the recommended maximum speed of the engine. For further engine-specific information, refer to the engine manufacturer's operation manual.

Engine Starting, Operation, and Shutdown

Prolonged idling of engines is not recommended, and is illegal in some states. Idling produces sulfuric acid that is absorbed by the lubricating oil, and eats into bearings, rings, valve stems, and engine surfaces. If you must idle the engine for cab heating or cooling, use the high idle function of the cruise control switches. An idle speed of 900 rpm should be enough to provide cab heat in ambient temperatures that are above freezing.

If the engine is programmed with an idle shutdown timer, 90 seconds before the preset shutdown time, the CHECK engine light will begin to flash at a rapid rate. If the position of the clutch pedal or service brake changes during this final 90 seconds the idle shutdown timer will be disabled until reset.

Cold-Weather Operation

Satisfactory performance of a diesel engine operating in low ambient temperatures requires modification of the engine, surrounding equipment, operating practices, and maintenance procedures. The lower the temperature, the greater the amount of modification required. For service products approved for use in cold weather for your engine, see the engine manufacturer's engine operation manual.

If satisfactory engine temperature is not maintained, maintenance costs will increase due to greater engine wear. If the engine coolant gets too cold, raw fuel will wash the lubricating oil off the cylinder walls and dilute the crankcase oil, causing all moving parts of the engine to suffer from poor lubrication.

If the engine is in good mechanical condition and the precautions necessary for cold-weather operation are taken, ordinary cold weather will not cause difficulty in starting or loss of efficiency.

The following points are important to observe when operating in cold weather.

- Check for cracks in the battery cases, for corrosion of the terminals, and for tightness of the cable clamps at the terminals.
- Charge the batteries to full capacity. Replace damaged batteries.
- If equipped, turn off the load disconnect switch after the engine is shut down to prevent battery discharge.
- Have the alternator output checked at an authorized Freightliner service provider.

- Check the condition and tension of the drive belts.
- Refer to the engine manufacturer's operation manual for recommended heaters, low-viscosity lubricating oils, winter-grade fuels, and approved coolants.
- Periodically check the coolant mixing ratio (concentration of antifreeze in the coolant). Add more if necessary.
- At outside temperatures below -4°F (-20°C), a coolant preheater is recommended.

A winterfront may be used to improve cab heating while idling. If a winterfront is used, at least 25% of the grille should remain open in sectioned stripes that run perpendicular to the charge air cooler tube-flow direction. Winterfronts should only be used when the ambient temperature remains below 10°F (-12°C).

High-Altitude Operation

Engines lose horsepower when operated at high altitude because the air is too thin to burn as much fuel as at sea level. This loss equals about three percent for each 1000 ft (300 m) altitude above sea level for a naturally aspirated engine.

All engines used on Freightliner vehicles are altitude-compensated by the use of a turbocharger. This reduces smoky exhaust at high altitudes, requires less downshifting, and allows the engine to make better use of its fuel. Nevertheless, shift gears as needed to avoid excessive exhaust smoke.

Engine Shutdown

1. With the vehicle stopped, set the parking brake and place the transmission in neutral.

NOTICE

Idle the engine one to two minutes before shutting it down. After hard operation, shutting down the engine without idling may cause damage to the turbocharger.

2. Allow the engine to idle one to two minutes before shutting it down. This allows the lubricating oil and the coolant to carry heat away from the combustion chambers, bearings, shafts, and seals.

Engine Starting, Operation, and Shutdown

NOTICE

Except in an emergency, do not shut down the engine when the coolant temperature is above 194°F (90°C). To do so could damage the engine.

3. Turn off the ignition switch and shut down the engine.

10

Optional Engine Systems

Engine Protection—Warning and Shutdown	10.1
Power Takeoff (PTO) Governor	10.2

Optional Engine Systems

Engine Protection—Warning and Shutdown

NOTE: The engine warning and shutdown system is present on vehicles that are equipped with an exhaust aftertreatment system (ATS).

The driver should be familiar with the vehicle warning system in order to bring the vehicle to a safe stop if necessary.

The engine will begin a warning and derate and/or shutdown process if the engine coolant temperature, coolant level, engine oil pressure, or component temperatures in the ATS reach preset levels. On some engines, the warning process will begin when the engine oil temperature, engine coolant temperature, or the intake air temperature reach preset levels. Detroit™ engines may also begin the warning and shutdown process if water is detected in the fuel.

See the engine manufacturer's operation manual for specific details for your vehicle. See [Chapter 11](#) for the warning and shutdown modes associated with the ATS.

Electronic engine protection can be specified as either SHUTDOWN or WARNING and DERATE.

WARNING

When the STOP engine or CHECK engine lamp illuminates, most engines are programmed to shut down automatically within 30 seconds. The driver must immediately move the vehicle to a safe location at the side of the road to prevent causing a hazardous situation that could cause bodily injury, property damage, or severe damage to the engine.

In SHUTDOWN mode, the red STOP engine lamp will illuminate when the problem is serious enough to reduce power or speed. See [Fig. 10.1](#). Engine power will ramp down, then the engine will shut down if the problem continues while in derate mode. The driver has 30 or 60 seconds (depending on the critical fault type) after the STOP engine lamp illuminates to move the vehicle safely off the road. If the vehicle cannot be moved to a safe location within that time, turn the ignition switch to OFF for at least five seconds, then restart the engine. Repeat this action until the vehicle is safely off the road.

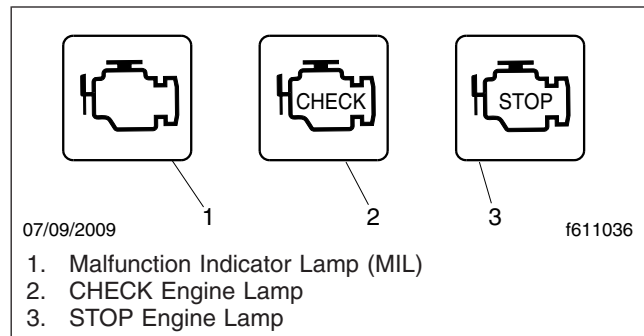

Fig. 10.1, Engine Warning Lamps

Do not operate the vehicle further until the problem causing the shutdown has been corrected.

Some vehicles may have a shutdown override switch, which can be used to momentarily override the shutdown sequence. This switch resets the shutdown timer, restoring power to the level before the derate. The switch must be pressed again after five seconds to obtain a subsequent override. See [Fig. 10.2](#).

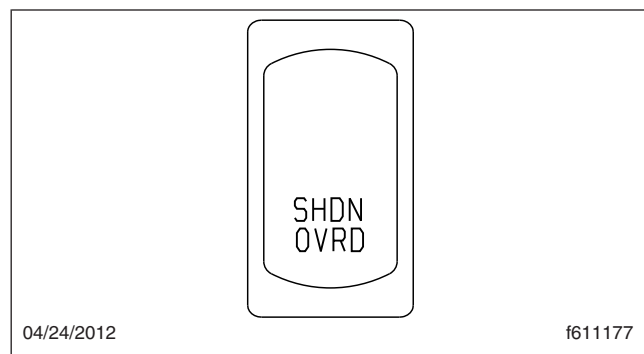

Fig. 10.2, Shutdown Override Switch

NOTICE

When a derate process takes place, get the vehicle serviced immediately in order to prevent severe damage to the engine.

Detroit engines may begin a warning and derate process if water is detected in the fuel, or for high engine coolant temperature. In WARNING and DERATE mode, the CHECK engine, STOP engine, or MIL lamp will illuminate to indicate an engine problem that requires service and the engine controls will begin a derate of engine output. Continuing to run

the engine while it is in derate mode could cause severe damage to the engine.

Power Takeoff (PTO) Governor

Engine power takeoffs (PTO) tap into engine power to run auxiliary devices, such as hydraulic pumps that power additional equipment. The following are general guidelines for operating a PTO.

1. Set the parking brake and put the transmission in neutral.
2. Press the dash PTO switch. Release the switch when the light begins to blink.

When the light illuminates steadily, the PTO is engaged and ready to operate. In stationary mode, the vehicle must remain in neutral with the parking brake set.

3. To activate mobile mode, shift from neutral to reverse, 1st, or 2nd gear. The clutch will open and the PTO will disengage for a moment.
4. Touch the accelerator pedal to close the clutch and engage the PTO in mobile mode. The PTO may be operated with the transmission in neutral or reverse, and 1st and 2nd gears only.

NOTE: Do not attempt to change gears while the vehicle is moving. The transmission will ignore the request.

5. To deactivate mobile mode, bring the vehicle to a stop. The clutch will open and shut down power to the PTO.
6. To resume stationary mode, shift to neutral. The PTO will engage.
7. To deactivate PTO, press the PTO switch again. When the light in the switch goes out, power to the PTO is shut off.

11

Emissions Reduction Components

Exhaust Aftertreatment System, Optional	11.1
---	------

Emissions Reduction Components

Exhaust Aftertreatment System, Optional

IMPORTANT: Depending upon local jurisdictional emissions guidelines, the vehicle may not be equipped with an emissions aftertreatment system (ATS). Adequate maintenance of the engine and the diesel particulate filter (DPF) are the responsibility of the owner/operator, and are essential to keep the emission levels low. Good operating practices, regular maintenance, and correct adjustments are factors that will help keep emissions within the regulations.

NOTICE

It is extremely important that the following guidelines be followed for engines that are equipped with an ATS, or damage may occur to the aftertreatment device, and the warranty may be compromised.

- Use ultralow-sulfur diesel with 15 ppm sulfur content or less.
- Do not use fuel blended with used engine lube oil or kerosene.
- Use only engine lube oil with a sulfated ash level less than 1.0 wt%.

IMPORTANT: See the engine manufacturer's operation manual for complete details and operation of the ATS.

The ATS varies according to engine manufacturer and vehicle configuration, but the exhaust muffler is replaced by an aftertreatment device (ATD). Inside the ATD, the exhaust first passes over the diesel oxidation catalyst (DOC), then passes through the diesel particulate filter (DPF), which traps soot particles. The soot is reduced to ash during a process called regeneration (regen).

Regeneration

The harder an engine works, the better it disposes of soot. If the exhaust temperature is high enough, a process called **passive regeneration** (regen) occurs as the vehicle is driven normally. However, if the engine isn't running hot enough, the electronic controls may initiate an **active regen**, whereby extra fuel is injected into the exhaust stream to elevate filter tem-

peratures and reduce the soot trapped in the DPF to ash. Active regen happens only when the vehicle is moving above a certain speed, determined by the engine manufacturer. See your engine operation manual for complete details. Both active and passive regen happen automatically, without driver input.

WARNING

Active regeneration can occur automatically anytime the vehicle is moving. The exhaust gas temperature could reach 1500°F (800°C), which is hot enough to cause a fire, heat damage to objects or materials, or personal injury to persons near the exhaust outlet. The exhaust temperature can remain high even after the vehicle has stopped. When stopping the vehicle shortly after an automatic regen, ensure the exhaust outlets are directed away from structures, trees, vegetation, flammable materials, and anything else that may be damaged or injured by exposure to high heat.

See *Regen Switches*, below, for instructions on preventing automatic regen if necessary.

When operating conditions do not allow for ATD filter cleaning by active or passive regen, the vehicle may require a driver-activated **parked regen**. When this occurs, the DPF lamp illuminates, indicating that a regen is required. The driver must either bring the vehicle up to highway speed to increase the load (thus starting an active regen), or park the vehicle and initiate a parked regen. See *Regen Switches*, below, for instructions on initiating a parked regen.

Regen Switches

The regen request switch, located on the dash, is used to initiate a parked regen. See [Fig. 11.1](#).

Some vehicles may be equipped with a regen request/inhibit switch. See [Fig. 11.1](#). To stop a regen in progress or prevent the start of a regen, press the lower half of the switch. Regen will be delayed until the switch is no longer active.

NOTE: The regen switch can initiate a parked regen only when the DPF lamp is illuminated.

WARNING

During parked regen, exhaust temperatures are very high and could cause a fire, heat damage to

Emissions Reduction Components

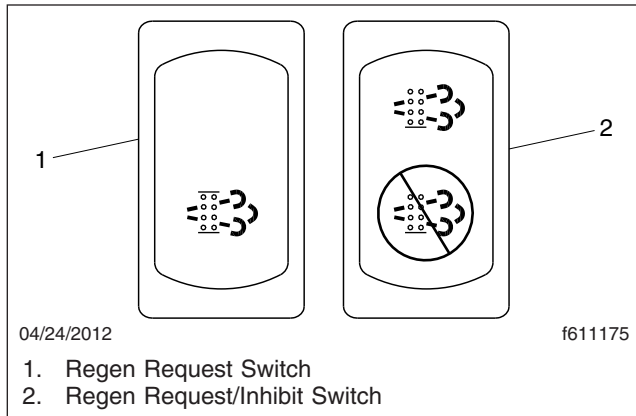

Fig. 11.1, ATS Regen Switches

objects or materials, or personal injury to persons near the exhaust outlet.

Before initiating a parked regeneration, make certain the exhaust outlets are directed away from structures, trees, vegetation, flammable materials, and anything else that may be damaged or injured by prolonged exposure to high heat.

To initiate a parked regen, perform the following steps.

1. Park the vehicle away from all flammable materials, put the transmission in neutral, and set the parking brake.
2. Start and warm the engine until the coolant temperature is at least 150°F (66°C).
3. Press and hold the regen request switch for five seconds. As the regen process is initiated, engine rpm increases and the HEST lamp illuminates to indicate extremely high exhaust temperatures.

IMPORTANT: The driver must remain with the vehicle during the entire regen cycle.

4. The regen cycle will finish after 20 to 60 minutes, at which time engine idle speed drops to normal and the vehicle can be driven normally. The HEST lamp is extinguished when vehicle speed exceeds 5 mph (8 km/h) or the system has cooled to normal operating temperature.
5. To stop a parked regen at any time during the process:
 - depress the clutch pedal or accelerator pedal;

- take the parking brake off;
- press and hold the regen inhibit switch until idle returns to normal;
- shut down the engine.

ATS Warning Lamps

There are three warning lamps that alert the driver of high exhaust temperature, the need to perform a parked regen or service the DPF, or of an engine fault that affects emissions.

See [Fig. 11.2](#) for an explanation of the ATS warnings, and actions required to avoid engine protection sequences.

Malfunction Indicator Lamp (MIL)

A steadily illuminated yellow malfunction indicator lamp (MIL) indicates an engine fault that affects emissions. See [Fig. 11.3](#).

DPF Status Lamp

When soot accumulates in the DPF and the DPF status lamp illuminates, see [Fig. 11.4](#), perform a parked regen or bring the vehicle up to highway speed to increase the load (thus starting an active regen).

If the DPF status lamp blinks while the CHECK engine lamp is illuminated, initiate a parked regen immediately in order to prevent an engine derate.





If the red STOP engine lamp illuminates with the blinking DPF lamp and the CHECK engine lamp, begin a parked regen in order to prevent an engine shutdown. Park the vehicle and perform a parked regen.

High Exhaust System Temperature (HEST) Lamp

Slow (10-second) flashing of the high exhaust system temperature (HEST) lamp indicates that a parked regen is in progress, and the engine's high idle speed is being controlled by the engine software, not the vehicle driver.

Steady illumination of the HEST lamp alerts the driver of high exhaust temperature during the regen process if the vehicle speed is below 5 mph (8 km/h), or during a parked regen. See [Fig. 11.5](#).

Emissions Reduction Components

EXHAUST AFTERTREATMENT SYSTEM INFORMATION					
INDICATOR LAMP(S)	 (Solid) Level 1	 (Flashing) Level 2	 (Flashing) CHECK Level 3	 (Flashing) CHECK STOP Level 4	 WARNING
Indicator Lamp Message(s)	Filter Regeneration Recommended	Filter Regeneration Necessary	Parked Regeneration Required – Engine Derate	Parked Regeneration Required – Engine Shut Down	HEST (High Exhaust System Temperature)
Diesel Particulate Filter Condition	Filter is reaching capacity.	Filter is now reaching maximum capacity.	Filter has reached maximum capacity.	Filter has exceeded maximum capacity.	Flashing A regeneration is in progress.
Required Action	Bring vehicle to highway speeds to allow for an Automatic Regeneration or perform a Parked Regeneration.	To avoid engine derate bring vehicle to highway speeds to allow for an Automatic Regeneration or perform a Parked Regeneration as soon as possible.	Vehicle must be parked and a Parked Regeneration must be performed – engine will begin derate.	Vehicle must be parked and a Parked Regeneration or Service Regeneration must be performed. Check engine operator's manual for details –engine will shut down.	Solid Exhaust Components and exhaust gas are at high temperature. When stationary, keep away from people and flammable materials or vapors.
For a driver performed Parked Regeneration, vehicle must be equipped with a dash mounted Regeneration Switch.					
See Engine Operator's Manual for complete Regeneration Instructions.					
<small>24-01583-0008</small>					

06/29/2009

f080147

Fig. 11.2, ATS Warning Lamps

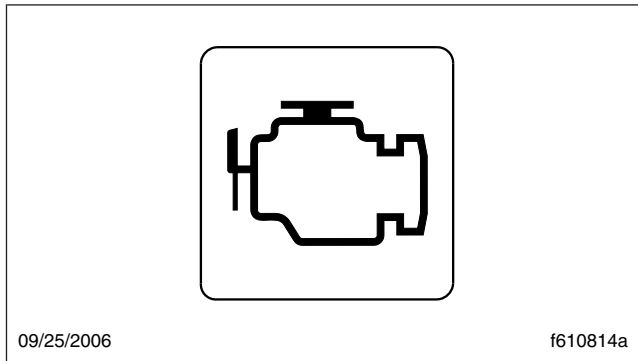

Fig. 11.3, Malfunction Indicator Lamp (MIL)

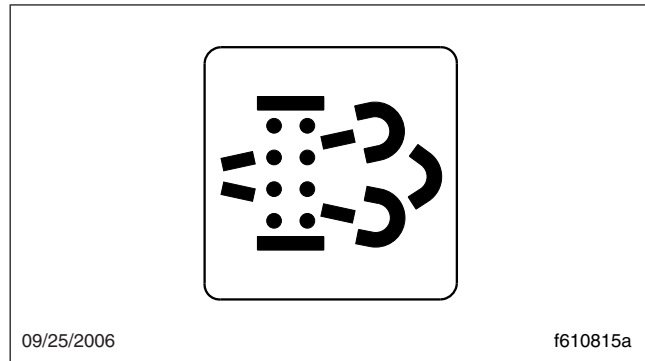

Fig. 11.4, DPF Status Lamp

Maintenance

Authorized service facilities must perform any DPF service. For warranty purposes, maintain a record that includes:

- date of cleaning or replacement;
- vehicle mileage;
- particulate filter part number and serial number.

Emissions Reduction Components

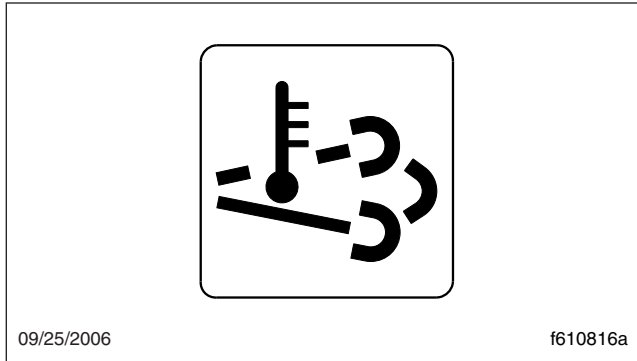

Fig. 11.5, HEST Lamp

12

Brake System

Air Brake System	12.1
Meritor WABCO® Antilock Braking System	12.3
Engine Brake	12.5

Brake System

Air Brake System

Brake System General Information

A dual air brake system consists of two independent air systems that use a single set of brake controls. Each system has its own reservoirs, plumbing, and brake chambers. The primary system operates the service brakes on the rear axle; the secondary system operates the service brakes on the front axle. Service brake signals from both systems are sent to the trailer.

WARNING

Do not operate the vehicle with the front brakes backed off or disconnected. Backing off or disconnecting the front brakes will not improve vehicle handling and may lead to loss of vehicle control, resulting in property damage or personal injury.

Brake System Components

The warning light and audible alert activate if air pressure drops below 64 to 76 psi (441 to 524 kPa) in either system. If this happens, check the air pressure gauges to determine which system has low air pressure. Although the vehicle's speed can be reduced using the foot brake control pedal, either the front or rear service brakes will not be operating at full capacity, causing a longer stopping distance. Bring the vehicle to a safe stop and have the air system repaired before continuing.

IMPORTANT: In the event of a total loss of service brakes with full system air pressure, use the parking brake control valve (yellow knob) to bring the vehicle to a complete stop in the safest location possible.

Before a vehicle with insufficient system air pressure can be moved, the spring parking brakes must be released by applying an external air source at the gladhands, or by manually caging the parking brake springs.

WARNING

Do not release the spring parking brakes and then drive the vehicle. There would be no means of stopping the vehicle, which could result in serious personal injury or vehicle damage. Before

releasing the spring parking brakes, make the connection to a towing vehicle or chock the tires.

After correcting the brake system problem, uncage the spring parking brakes before resuming normal vehicle operation.

Primary Air Brake System

Loss of air pressure in the primary air system causes the rear service brakes to become inoperative, and the parking brake to engage. The secondary air system will continue to operate the front brakes and the trailer brakes (if equipped).

Secondary Air System

Loss of air pressure in the secondary air system causes the front axle brakes to become inoperative. The primary air system will continue to operate the rear service brakes and the trailer brakes (if equipped).

Brake System Operation

Before driving your vehicle, allow time for the air compressor to build up a minimum of 100 psi (689 kPa) pressure in both the primary and secondary systems. Monitor the air pressure system by observing the air pressure gauges and the low-air-pressure warning light and buzzer. The warning light and buzzer shut off when air pressure in both systems reaches 64 to 76 psi (441 to 524 kPa).

IMPORTANT: Before driving the vehicle, secure all loose items in the cab so that they will not fly forward during a full brake application. Make sure all passengers are wearing seat belts.

During normal brake stops, depress the foot brake control pedal until braking action slows down the vehicle. Increase or decrease the pressure on the pedal so that the vehicle comes to a smooth, safe stop. Apply the spring parking brakes if the vehicle is to be parked.

IMPORTANT: An air brake proportioning system may be used in tractor air brake systems when the vehicle is not equipped with an antilock braking system (ABS). When operating in bob-tail mode, the rear brake chambers (on which the axle load has been greatly reduced) receive reduced (proportional) air pressure, while the front axle brake chambers receive full (normal)

air pressure. This results in a different brake pedal "feel," as the pedal seems to require more travel and/or effort to slow or stop the vehicle. However, the air brake proportioning system actually improves vehicle control when the tractor is in bobtail mode. When the tractor is towing a trailer, the rear brake chambers will receive full (normal) application air pressure.

When parking a vehicle attached to a trailer that does not have spring parking brakes, apply the tractor parking brakes. Chock the trailer tires before disconnecting the vehicle from the trailer.

WARNING

If a trailer or combination vehicle is not equipped with spring parking brakes, do not park it by pulling out only the trailer air supply valve knob. This would apply only the trailer service brakes. If air were to bleed from the trailer brake system, the trailer brakes would release, possibly causing an unattended runaway vehicle.

NOTICE

Never apply the service and spring parking brakes simultaneously. To do so puts excessive input force on brake components, which could damage or cause eventual failure of brake actuating components.

Brake Controls

The trailer brake lever (hand control valve) is used for applying the trailer brakes without applying the truck or tractor service brakes. It is usually mounted on the right-hand control panel. See Fig. 12.1. The valve can be partially or fully applied, but in any partially on position it will be overridden by a full application of the service brake pedal. Moving the lever down applies the trailer brakes, moving it up releases them. The lever will automatically return to the up position when it is released.

WARNING

Do not use the trailer service brakes for parking; they are not designed for this purpose. If air bleeds out of the trailer air tank during parking, the vehicle could roll, causing serious personal injury or property damage.

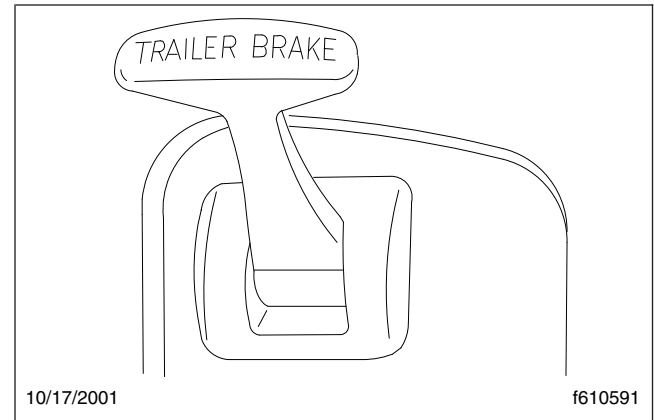

Fig. 12.1, Trailer Brake Lever

The red octagon-shaped knob in the control panel actuates the trailer air supply valve. See Fig. 12.2. After the vehicle's air hoses are connected to a trailer and the pressure in both air systems is at least 65 psi (448 kPa), the trailer air supply valve must be pushed in. It should stay in to charge the trailer air supply system and to release the trailer spring parking brakes.

Pull the trailer air supply valve out before disconnecting a trailer or when operating a vehicle without a trailer. If pressure in both air systems drops to 35 to 45 psi (242 to 310 kPa), the trailer air supply valve automatically pops out, exhausting the trailer air supply, and applying the trailer service or spring parking brakes.

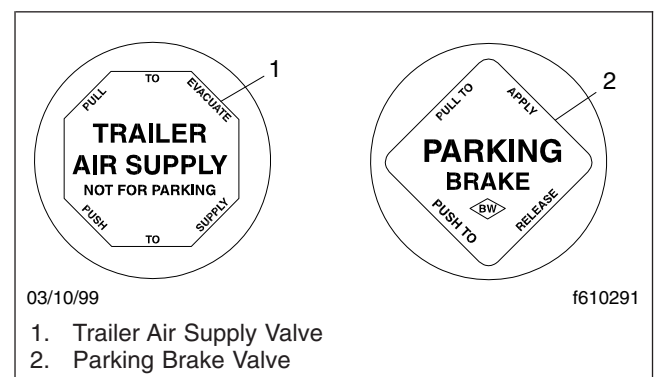

Fig. 12.2, Brake Valves

The yellow diamond-shaped knob in the control panel actuates the parking brake valve. See Fig. 12.2. Pulling out the parking brake valve applies both the tractor and trailer spring parking brakes and

Brake System

automatically causes the trailer air supply valve to pop out.

NOTICE

Do not use the spring parking brakes if the service brakes are hot, such as after descending a steep grade. To do so could damage the brakes. Allow hot brakes to cool before using the spring parking brakes.

Do not use the spring parking brakes during freezing temperatures if the service brakes are wet. To do so could cause them to freeze. If the brakes are wet, drive the vehicle in low gear and lightly apply the brakes to heat and dry them.

If the trailer is not equipped with spring parking brakes, pulling out the parking brake valve applies the tractor spring parking brakes and the trailer service brakes. When the tractor and trailer parking brakes (or trailer service brakes) are both applied, the trailer brakes are released by pushing in the trailer air supply valve, leaving the tractor parking brakes applied. Air pressure in the primary or secondary reservoir must be at least 65 psi (448 kPa) before the tractor spring parking brakes, or the trailer service or spring parking brakes, can be released.

Automatic Slack Adjusters



Manually adjusting an automatic slack adjuster to bring the pushrod stroke within legal limits is likely masking a mechanical problem. Adjustment is not a repair. Before adjusting an automatic slack adjuster, troubleshoot the foundation brake system and inspect it for worn or damaged components. Improperly maintaining the vehicle braking system may lead to brake failure, resulting in property damage, personal injury, or death.

Automatic slack adjusters should never be manually adjusted except during routine maintenance of the foundation brakes (e.g., replacing shoes), during slack adjuster installation, or in an emergency situation.

When the brake pushrod stroke exceeds the legal brake adjustment limit on a vehicle, there is likely a mechanical problem with the foundation brake components or the adjuster is improperly installed.

Visit a repair facility as soon as possible when brakes equipped with automatic slack adjusters are determined to be out of adjustment.

Meritor WABCO® Antilock Braking System

The Meritor WABCO Antilock Braking System (ABS) is an electronic wheel speed monitoring and control system that works with the standard air brake system. ABS passively monitors vehicle wheel speed at all times, and controls wheel speed during emergency stops.

IMPORTANT: For proper ABS system operation, do not change tire sizes. The sizes of the tires installed during production are programmed into the electronic control unit. Installing different-sized tires could result in a reduced braking force, leading to longer stopping distances.

ABS includes signal-generating tone wheels and sensors located in the wheel hubs of each sensed wheel. The sensors transmit vehicle wheel speed information to an electronic control unit (located behind the center dash). The control unit's main circuit interprets the speed sensor signals and calculates wheel speed, wheel retardation, and a vehicle reference speed. If the calculations indicate wheel lockup, the main circuit signals the appropriate modulator valve to reduce braking pressure. During emergency braking, the modulator valve alternately reduces, increases, or maintains air pressure supply in the brake chamber to prevent front and rear wheel lockup.

The electronic control unit (ECU) also has a safety circuit that constantly monitors the wheel sensors, traction control valve (if equipped), modulator valves, and the electrical circuitry.

The Meritor WABCO ABS combines one front-axle control channel with one rear-axle control channel to form one control circuit. For example, the sensor and modulator valve on the left-front axle form a control circuit with the sensor and modulator valve on the right-rear axle. If, during vehicle operation, the safety circuit senses a failure in any part of the ABS, the vehicle ABS warning indicator illuminates and the control circuit where the failure occurred is switched to normal braking action. See [Fig. 12.3](#). The remaining control circuit will retain the ABS effect. Even if the ABS is completely inoperative, normal braking

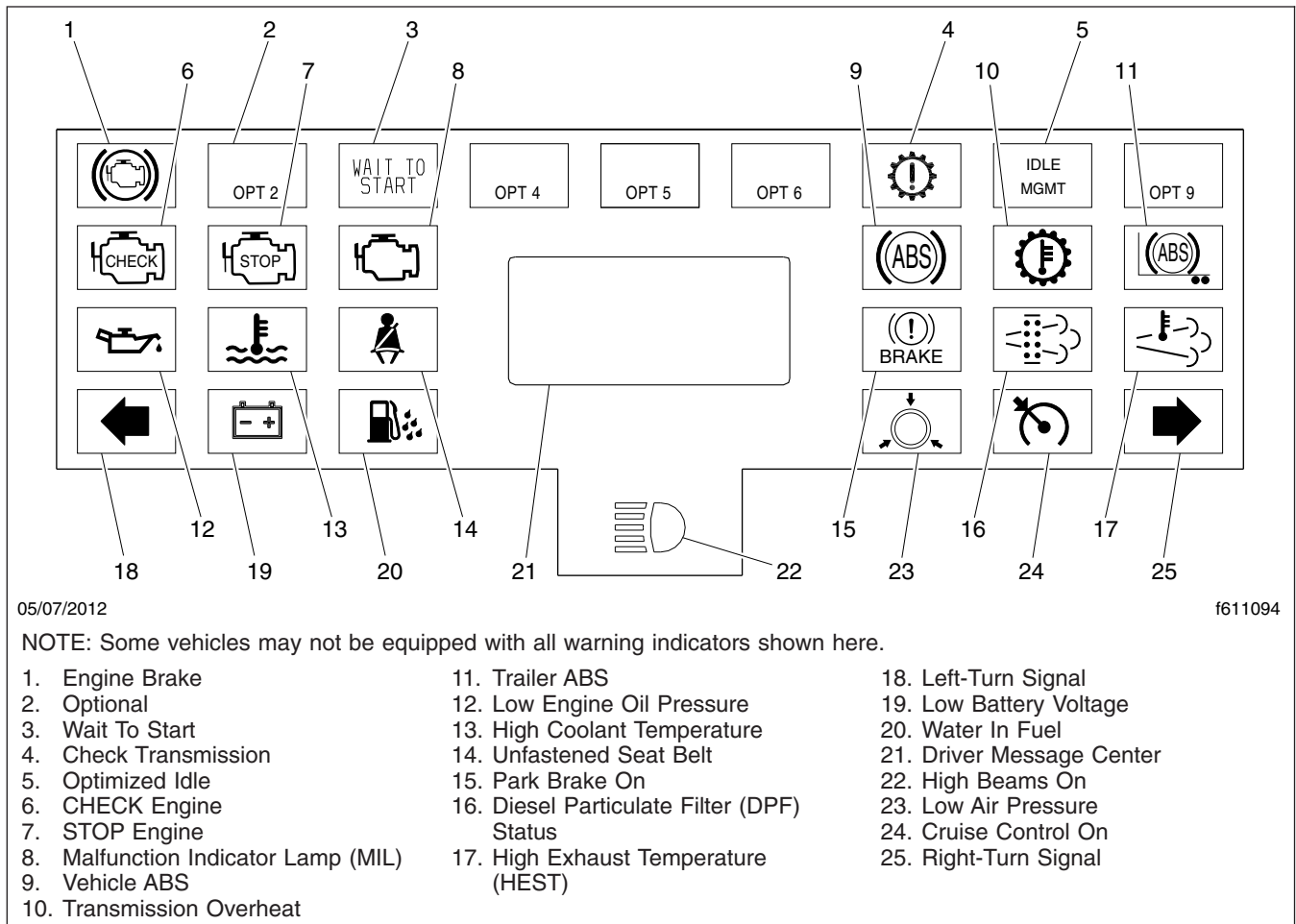

Fig. 12.3, ICU3 Message Center (typical)

ability is maintained. An exception would be if a modulator valve (or combination modulator valve) is damaged and inoperative. As these components are an integral part of the air brake system, normal braking may be impaired or inoperative.

During emergency or reduced-traction stops, fully depress the brake pedal until the vehicle comes to a safe stop. *Do not pump the brake pedal.* With the brake pedal fully depressed, the ABS will control all wheels to provide steering control and a reduced braking distance.

Although the ABS improves vehicle control during emergency braking situations, the driver still has the responsibility to change driving styles depending on existing traffic and road conditions. For example, the

ABS cannot prevent an accident if the driver is speeding or following too closely.

Trailer ABS Compatibility

The Meritor WABCO ABS is designed to communicate with a trailer ABS, if they are compatible. Compatibility will result in the illumination of the trailer ABS warning indicator during vehicle start-up and fault detection. See [Fig. 12.3](#).

The trailer ABS warning indicator will not illuminate unless a compatible trailer is connected to the tractor. The dash-mounted lamp will operate as follows when a compatible trailer is properly connected to the tractor:

Brake System

- When the ignition key is turned to the ON position, the trailer ABS warning indicator will illuminate momentarily, then turn off.
- If the lamp illuminates momentarily during vehicle operation, then shuts off, a fault was detected and corrected.
- If the lamp illuminates and stays on during vehicle operation, there is a fault with the trailer ABS. Repair the trailer ABS system immediately to ensure full antilock braking capability.

IMPORTANT: If a compatible trailer is connected, and the lamp is not illuminating momentarily when the ignition key is turned to the ON position, it is possible that the lamp is burnt out.

Automatic Traction Control

Vehicles with electronic engines and ABS may have Automatic Traction Control (ATC). On these vehicles, the ATC system automatically limits wheel spin during reduced-traction situations. In normal braking applications, the standard air brake system is in effect.

An additional solenoid valve is installed. During reduced-traction situations, the ATC solenoid valve controls air pressure to the modulator valves and they in turn increase, hold, or reduce pressure to the appropriate brake chambers to provide better traction whenever wheel spin occurs.

When the ATC system is in the NORMAL mode, it will apply gentle braking to the spinning wheel, to feed power to the wheel(s) with better traction. If both wheels are spinning, the system will signal the engine to reduce power.

ATC includes a deep snow and mud option to increase available traction on extra-soft surfaces like snow, mud, or gravel. A rocker switch labeled ATC is located on the dash. See [Fig. 12.4](#). Pressing the switch temporarily allows more drive wheel spin. Activating the deep snow and mud option causes the WHEEL SPIN lamp to flash. Pressing the switch again cycles the system back to normal operation.

NOTICE

The deep snow and mud option is intended to be used under specific slippery conditions that require momentary increased wheel spin. Using this option for an extended period of time may damage the vehicle brake system.

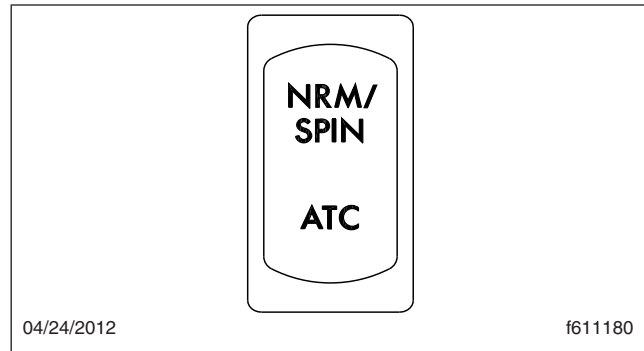

Fig. 12.4, ATC Switch

After the ignition switch is turned on, the vehicle ABS lamp and the WHEEL SPIN indicator lamp come on for about three seconds. After three seconds, the warning lights go out if all of the tractor's ABS components are working.

IMPORTANT: If any of the ABS warning lights do not work as described above, or come on while driving, repair the ABS immediately to ensure full antilock braking capability.

Engine Brake

WARNING

To avoid injury from loss of vehicle control, do not activate the engine brake system under the following conditions:

- **on wet or slippery pavement, unless the vehicle is equipped with antilock braking system (ABS) and you have had prior experience driving under these conditions;**
- **when driving without a trailer or pulling an empty trailer;**
- **if the tractor drive wheels begin to lock, or there is fishtail motion after the engine brake is activated.**

Each engine manufacturer uses a specific engine brake for their engine. Regardless of the manufacturer, the engine brake is operated with the principles outlined in this chapter. Refer to the engine manufacturer's operation manual for details of their particular engine brake product.

Whenever vehicle braking is required on good road conditions, the engine brake may be used in conjunction with the service brakes. There is no time limit for operation of the engine brake. However, an engine brake does not provide the precise control available from the service brakes, and is not a substitute for a service braking system.

⚠ WARNING

Usage of the engine brake as the primary braking system can cause unpredictable stopping distances, that could result in personal injury or property damage. Service brakes are the primary vehicle braking system.

There are two switches that control the engine brake.

- The dash mounted ON/OFF switch (ENG BRK), is used to turn the engine brake ON and OFF. See [Fig. 12.5](#).
- The HI/MED/LO (in some cases HI/LO) engine brake level switch on the dash, controls the amount of engine braking.

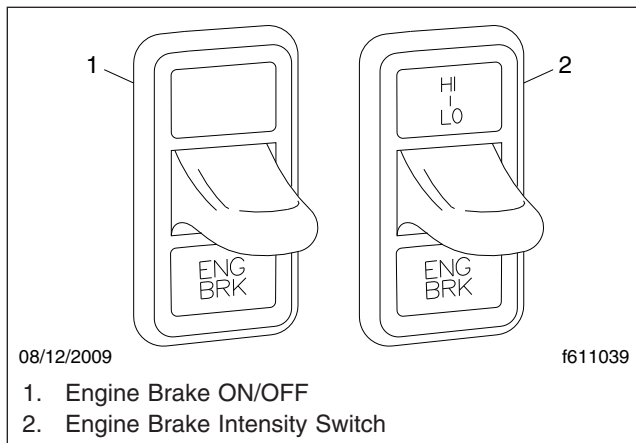

Fig. 12.5, Engine Brake Switches

Since the engine brake is most effective at rated engine speed, gear selection is very important. Gearing down the vehicle, within the limits of the rated engine speed, makes the engine brake more effective. Recommended engine braking speed is above 1800 rpm and below the rated speed.

⚠ WARNING

The engine brake must be disengaged when shifting gears using the clutch pedal. If the engine brake is engaged when the transmission is in neutral, the braking power of the engine brake can stall the engine, which could result in loss of vehicle control, possibly causing personal injury and property damage.

NOTICE

Do not allow the engine to exceed 2500 rpm. Serious engine damage could result.

"Control speed" is the speed at which the engine brake performs 100 percent of the required downhill braking, resulting in a constant speed of descent. The control speed varies, depending on vehicle weight and the downhill grade.

For faster descent, select a higher gear than that used for control speed. Service brakes must then be used intermittently to prevent engine overspeed and to maintain desired vehicle speed.

A driver may descend slower than control speed by selecting a lower gear, being careful not to overspeed the engine. Occasional deactivation of the engine brake may be necessary to maintain the designated road speed under these conditions.

Below a set engine temperature when the engine is cold, the brake may be disabled depending on the brake type.

Engine Brake Operation

To activate the engine brake after the engine is warmed up and the vehicle is in motion:

- Remove your feet from both the clutch and throttle pedals. Press the dash-mounted ENG BRK switch to toggle the engine brake ON. See [Fig. 12.4](#).
The engine brake will engage at the rate last set on the brake intensity switch.
- Move the intensity switch to the desired intensity. Depending on the engine model, LO will provide 1/3 or 1/2 of the full braking capacity of the engine. HI will provide maximum engine braking.

Brake System

Use the dash-mounted switch set at the LO position when driving on flat, open stretches of road. If the service brakes are still required to slow down on a grade, switch to a higher setting on the dash switch, until there is no need for the service brakes. Grade descent speed should be such that the service brakes are used infrequently and that they remain cool, thus retaining their effectiveness.

- For maximum retarding, maintain the top governed speed of the engine through the appropriate selection of gears. When shifting gears, the engine brake will disengage when the clutch pedal is depressed, then engage when the clutch pedal is released.
- To cancel the engine brake application, toggle the ENG BRK switch OFF.

If the engine is equipped with both cruise control and an engine brake, the engine brake can operate automatically while in cruise control mode.

The engine brake will only operate when the accelerator pedal is fully released. Disengaging the clutch will prevent the engine brake from operating.

Vehicles equipped with antilock braking systems (ABS) have the ability to turn the engine brake off if a wheel-slip condition is detected. The engine brake will automatically turn itself back on once the wheel slip is no longer detected.

13

Steering System

Steering System General Information	13.1
---	------

Steering System

Steering System General Information

The power steering system includes the integral power steering gear, hydraulic hoses, power steering pump, reservoir, steering wheel and column, and other components. Some models are also equipped with a separate hydraulic power cylinder on the right side of the front axle, or a right-hand slave gear.

The power steering pump, driven by the engine, provides the power assist for the steering system. If the engine is not running, there is no power assist. If the power-assist feature does not work due to hydraulic fluid loss, steering pump damage, or some other cause, bring the vehicle to a safe stop. Do not drive the vehicle until the cause of the problem has been corrected.



Driving the vehicle without the power-assist feature of the steering system requires much greater effort, especially in sharp turns or at low speeds, which could result in an accident and possible injury.

NOTICE

Never steam clean or high-pressure wash the steering gear. Internal damage to gear seals, and ultimately the steering gear, can result.

Drivers should carefully use the power available with a power steering system. If the front tires become lodged in a deep chuckhole or rut, drive the vehicle out instead of using the steering system to lift the tires out of the hole.

NOTICE

Avoid turning the tires when they are against a curb, as this places a heavy load on steering components and could damage them.

14

Manual Transmissions and Clutch

Eaton Fuller® Transmission, Operating Tips	14.1
Eaton Fuller Splitter and Range-Shift Transmissions	14.1
Clutch	14.4

Manual Transmissions and Clutch

Eaton Fuller® Transmission, Operating Tips

Refer to the Eaton website for additional information, www.roadranger.com.

Follow these important operation principles:

- For all conditions, use the highest gear that is still low enough to start the vehicle moving with the engine at or near idle speed, and without slipping the clutch excessively.

When operating on-highway with no load or under ideal conditions, use 1st gear to start the vehicle moving forward.

When operating off-road or under adverse conditions, use LOW gear to start the vehicle moving forward.

- Use the clutch brake to stop gear rotation when shifting into LOW or reverse while the vehicle is stationary. The clutch brake is actuated by depressing the clutch pedal all the way to the floor.
- Partially disengage the clutch to break engine torque during normal gear shifts.
- Double-clutch between all upshifts and downshifts that require movement of the shift knob. Splitting of gears does not require movement of the shift knob.
- Never push the range-preselection lever down into low range while operating in high range, except when downshifting from 5th gear to 4th gear.
- Do not shift from high range to low range at high vehicle speeds.
- Never make a range shift or a splitter shift while the vehicle is in reverse.
- Never move the range-preselection lever with the transmission in neutral while the vehicle is moving.
- Skip ratios while shifting *only* when operating conditions permit, depending on the load, grade, and road speed.
- Never coast with the transmission in neutral.

Eaton Fuller Splitter and Range-Shift Transmissions

Combination splitter and range-shift transmissions allow the choice of two splitter ratios in each gear, as well as the additional ratios provided by a low range and a high range.

General Information, Range-Shift Transmissions

IMPORTANT: Not all ratios are used in each range, and the shift patterns vary between transmissions. Read the shift pattern decal on the dash for the operating instructions for the transmission installed in your vehicle.

The range-preselection lever selects the low or high range for each transmission ratio. It is used once during an upshift sequence and once during a downshift sequence.

To operate a range-shift transmission, move the gear shift lever through all the low-range gear positions and then pull the range-preselection lever up to move into the high-range ratios.

IMPORTANT: Always preselect range shifts when upshifting or downshifting. Preselection requires that the range lever be moved to the necessary position before starting to shift. Preselecting range shifts prevents damage to the transmission and provides for smoother shifts.

General Information, Splitter Control

Depending on the transmission model, some ratios can be split using the splitter-control button (located on the side of the gear shift lever).

IMPORTANT: Always preselect splitter shifts. Preselection requires that the splitter-control button be moved to the necessary position before starting to shift. Preselecting splitter shifts allows for smoother and faster shifting. Complete the shift immediately after preselecting the split to avoid unnecessary wear on transmission components.

Eaton Fuller 13-Speed Splitter and Range-Shift Transmissions

Eaton Fuller 13-speed transmissions have thirteen forward speeds and two reverse speeds. Each transmission consists of a 5-speed front section and a 3-speed auxiliary section. The auxiliary section contains low- and high-range ratios, plus a splitter gear. See [Fig. 14.1](#) for the shift pattern.

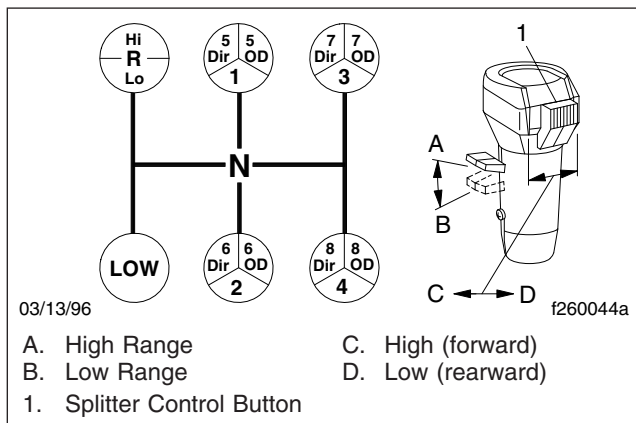

Fig. 14.1, Eaton Fuller 13-Speed Transmission Shift Pattern

LOW gear is used only as a starting gear; it is never used with the transmission in high range. The other four ratios are used once in the low range and once again in the high range.

High range gear ratios can be split by using the splitter-control button with the underdrive ratio (RT models), or overdrive ratio (RTO models). Low range gear ratios cannot be split.

Upshifting

1. Put the transmission in neutral. Start the engine and bring the air system pressure up to 100 to 120 psi (689 to 827 kPa).
2. Position the range-preselection lever down, in low range.
3. Make sure the splitter-control button is in the low (rearward) position. See [Fig. 14.1](#).
4. To start the vehicle moving, press the clutch pedal to the floor, shift into LOW or 1st gear, then engage the clutch with the engine at or near idle speed. Accelerate to 80 percent of engine governed speed.

5. Upshift from LOW (or 1st gear) through 4th gear, double-clutching when moving the gear shift lever, and accelerating to 80 percent of engine governed speed.
6. While in 4th gear, pull the range-preselection lever up into high range and move the splitter-control button to the low (rearward) position. Double-clutch into 5th gear, engage the clutch, and accelerate.
7. Upshift progressively through the high range gears.

To shift from 5th direct to 5th overdrive (or 5th underdrive to 5th direct on RT model transmissions), move the splitter-control button to the high position, then immediately release the accelerator. Press and release the clutch pedal, then, accelerate again.

Continue upshifting through the shift pattern. Double-clutch when moving the gear shift lever (6th to 7th, etc.); single-clutch during split shifts (6th direct to 6th overdrive, etc.).

Downshifting

IMPORTANT: Never use the clutch brake when downshifting, or as a brake to slow the vehicle.

1. To downshift from 8th overdrive to 8th direct (or 8th direct to 8th underdrive on RT model transmissions), move the splitter-control button to the low position, then immediately release the accelerator. Press and release the clutch pedal, then depress the accelerator pedal once the transmission has shifted.
2. Start the downshift from 8th direct to 7th overdrive by moving the splitter-control button to the high position, then double-clutch into 7th gear.
3. Downshift progressively through each of the high range gears, alternating the procedures in steps 1 and 2 above until reaching 5th direct.
4. When in 5th direct and ready for the downshift to 4th, push the range-preselection lever down and move the splitter-control button to the high position. Double-clutch into 4th gear, engage the clutch, and depress the accelerator pedal.
5. Continue downshifting from 4th gear to 1st gear, as conditions require.

Manual Transmissions and Clutch

Eaton Fuller 18-Speed Splitter and Range-Shift Transmissions

Eaton Fuller 18-speed transmissions have eighteen forward speeds and four reverse speeds. Each transmission consists of a 5-speed front section and a 4-speed auxiliary section. The auxiliary section contains low- and high-range ratios, plus a splitter gear. See **Fig. 14.2**.

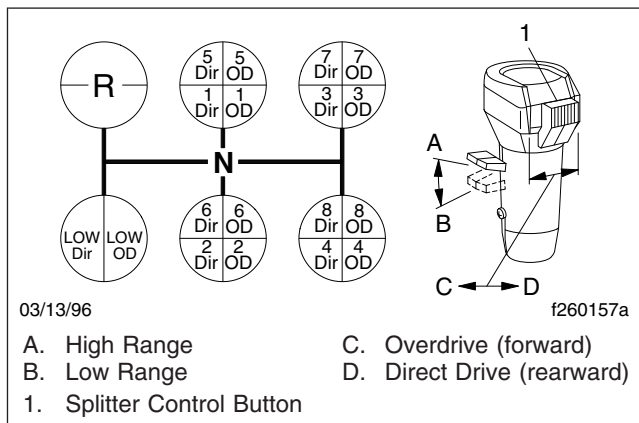

Fig. 14.2, Eaton Fuller 18-Speed Transmission Shift Pattern

LOW gear in the front section is used only as a starting gear; it is never used when the transmission is in high range. LOW gear can be split, to provide both a direct and an overdrive ratio.

Upshifting

1. Put the transmission in neutral. Start the engine and bring the air system pressure up to 100 to 120 psi (689 to 827 kPa).
2. Position the range-preselection lever down, in low range and make sure the splitter-control button is in the low position. See **Fig. 14.2**.
3. To start the vehicle moving, press the clutch pedal to the floor, shift into LOW, then engage the clutch with the engine at or near idle speed. To shift from LOW direct to LOW overdrive, move the splitter-control button into the overdrive (forward) position, then immediately release the accelerator. Press and release the clutch pedal, and accelerate.
4. Upshift from LOW overdrive to 1st direct by first moving the splitter-control button into the direct

drive (rearward) position (**Fig. 14.2**). Double-clutch into 1st gear.

Continue upshifting through the shift pattern. Double-clutch when moving the gear shift lever (1st to 2nd to 3rd to 4th); single-clutch during split shifts (1st direct to 1st overdrive, etc.).

5. When in 4th overdrive, use the range-preselection lever and the splitter-control button to upshift to 5th gear.

While in 4th gear, pull the range-preselection lever up into high range and move the splitter-control button to the low position. Double-clutch into 5th gear, engage the clutch, and accelerate.

6. Upshift progressively through the high range gears.

To shift from 5th direct to 5th overdrive (or 5th underdrive to 5th direct on RT model transmissions), move the splitter-control button to the high position, then immediately release the accelerator. Press and release the clutch pedal, and accelerate.

Continue upshifting through the shift pattern. Double-clutch when moving the gear shift lever (6th to 7th, etc.); single-clutch during split shifts (6th direct to 6th overdrive, etc.).

Downshifting

IMPORTANT: Never use the clutch brake when downshifting, or as a brake to slow the vehicle.

1. To downshift from 8th overdrive to 8th direct (or 8th direct to 8th underdrive on RT model transmissions), move the splitter-control button to the low position, then immediately release the accelerator. Press and release the clutch pedal, then depress the accelerator pedal once the transmission has shifted.
2. Start the downshift from 8th direct to 7th overdrive by moving the splitter-control button to the high position, then immediately double-clutch into 7th gear.
3. Downshift progressively through each of the high range gears, alternating the procedures in steps 1 and 2 above until reaching 5th direct.
4. When in 4th overdrive, push the range-preselection lever down and move the splitter-control button to the high position. Double-clutch

Manual Transmissions and Clutch

through into 4th gear, engage the clutch, and depress the accelerator pedal.

- Continue downshifting from 4th overdrive to 4th direct, then 4th direct to 3rd overdrive, etc. Double-clutch when moving the gear shift lever (4th to 3th, etc.); single-clutch during split shifts (4th direct to 3rd overdrive, etc.).

Eaton Fuller 10-Speed Range-Shift Transmissions

Eaton Fuller 10-speed transmissions have ten selective, evenly-spaced forward ratios. Each transmission consists of a 5-speed front section, and a 2-speed auxiliary section. The ten forward speeds are obtained by twice using a 5-speed shift pattern: the first time in low range, the second time in high range. See Fig. 14.3 for the shift patterns, noting that the 4th/9th and the 5th/10th shift positions in the RT (direct ratio) transmissions are directly opposite in the RTO (overdrive ratio) transmissions.

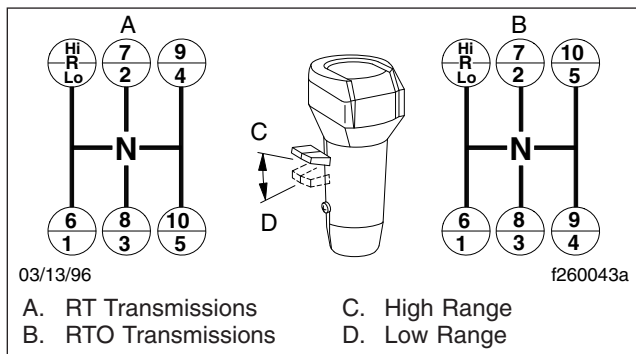

Fig. 14.3, Eaton Fuller 10-Speed RT and RTO Transmissions Shift Patterns

Upshifting

- Put the transmission in neutral. Start the engine and bring the air system pressure up to 100 to 120 psi (689 to 827 kPa).
- Position the range-preselection lever down, in low range.
- To start the vehicle moving, press the clutch pedal to the floor; shift into 1st gear, then engage the clutch with the engine at or near idle speed. Accelerate to 80 percent of engine governed speed.

- Upshift progressively from 1st gear through 5th gear, double-clutching when moving the gear shift lever.
- When in 5th gear and ready to move to 6th gear, pull the range-preselection lever up into the high range. Double-clutch into 6th gear, engage the clutch, and accelerate.

NOTE: If after attempting to shift into the high range the transmission remains in neutral, the range synchronizer protection device may be activated. Move the gear shift lever to neutral to allow the range shift to complete, then shift back into gear.

- Upshift progressively through the high range gears, double-clutching when moving the gear shift lever and accelerating to 80 percent of engine governed speed.

Downshifting

IMPORTANT: Never use the clutch brake when downshifting, or as a brake to slow the vehicle.

- Downshift progressively through each of the high range gears, double-clutching between shifts.
- When in 5th gear and ready to move to 4th gear, push the range-preselection lever down into the low range. Double-clutch into 4th gear, engage the clutch, and depress the accelerator.
- Downshift progressively through the low range gears, double-clutching when moving the gear shift lever, as conditions require.

Clutch

Clutch General Information

To ensure long service life of the clutch, start in the right gear, be alert to clutch malfunctions, and know when to adjust the clutch.

Typical operation will not break down the clutch friction surfaces. Heat and wear are almost nonexistent when a clutch is fully engaged. However, during the moment of engagement, when the clutch is picking up the load, considerable heat is generated. If a clutch slips excessively, high temperatures develop quickly between the flywheel, driven discs, and pressure plates. An improperly adjusted or slipping clutch

Manual Transmissions and Clutch

can generate temperatures high enough to destroy the clutch.

Clutch Operation

Clutch Break-In

The clutch may slip for a short time while the friction surfaces break-in on a new or newly-installed clutch.

NOTICE

Do not allow the clutch to slip longer than two seconds. Clutch slippage for longer than two seconds may severely damage the clutch disc, pressure plate, or flywheel. Damage caused by clutch slippage due to improper break-in is not warrantable.

During initial operation of a new vehicle or a vehicle with a new clutch, check for clutch slippage during acceleration. If the clutch slips, decelerate until the clutch does not slip. Allow the clutch to cool 15 to 30 seconds, then gradually accelerate again. If the clutch continues to slip, repeat the procedure as many as five times. If the clutch slips after five attempts, stop the vehicle and allow the clutch to cool for at least one hour. Notify your Freightliner dealer of the problem.

Moving the Vehicle in the Proper Gear

An empty vehicle can be started in a higher gear than can a partially- or fully-loaded vehicle. Select the gear combination that allows the vehicle to start moving with an idling engine or, if necessary, just enough throttle to prevent stalling the engine.

Gear Shifting Techniques

Upshift into a higher gear only when the vehicle speed allows the transmission input shaft speed to match the flywheel speed when engaging the clutch. This technique results in the smallest speed difference between the clutch disc and the flywheel, and causes the least heat and wear on the clutch assembly. When downshifting, increase the input shaft speed to match the flywheel by slightly revving the engine.

Vehicle Loading

Clutches are designed for specific vehicle applications and loads.

NOTICE

Exceeding vehicle load limits can result in damage to the clutch and the entire powertrain.

Clutch Brake

Apply the clutch brake by depressing the clutch pedal all the way to the floor plate. The last part of pedal travel will compress the clutch brake plates together, stopping the transmission input shaft. The clutch brake stops the transmission gears from rotating in order to quickly engage a transmission gear after idling in neutral.

NOTICE

Never apply the clutch brake when making downshifts or upshifts. If the clutch brake is applied when the vehicle is moving, the clutch brake will try to stop or decelerate the vehicle, causing rapid wear of the clutch brake friction discs. Considerable heat will be generated, causing damage to the release bearings and the transmission front bearings.

Using the Clutch

Use the clutch pedal only when starting the engine, launching the vehicle from a stop, or shifting. To launch a stationary vehicle, depress the clutch pedal all the way to the floor plate (see **Clutch Brake** above) and shift from neutral to a low gear. Slowly raise your foot until the clutch starts to engage. In this position the clutch is starting to connect the transmission input shaft to the flywheel and is causing the most heat and wear. Slightly increase the engine speed and smoothly allow the clutch pedal to return to the rest position. Do not allow the clutch to remain in the partially-engaged position any longer than necessary to obtain a smooth start.

Double-clutch to shift gears while the vehicle is moving. Depress the clutch pedal most of the way in, but not all the way to the floor plate. Depressing the clutch pedal to the floor plate will engage the clutch brake. Shift the transmission into neutral and fully release the clutch pedal. When upshifting, wait for the engine speed to decrease to the road speed. When downshifting, increase the engine speed to match the road speed. Fully release the clutch pedal after completing the shift.

Manual Transmissions and Clutch

NOTICE

Riding the clutch while driving is damaging to the clutch because partial clutch engagement causes slippage and heat. Resting your foot on the clutch pedal will also put a constant thrust load on the release bearing, thinning the bearing lubricant and increasing the wear on the bearing.

Holding the Vehicle On an Incline

Always use the vehicle service brakes to prevent the vehicle from rolling backwards while stopped on a hill. Slipping the clutch on a hill to maintain vehicle position will quickly damage the clutch assembly.

Coasting

Coasting with the clutch pedal depressed and the transmission in a low gear can cause high driven disc speed. The clutch speed can be much higher under these conditions than when the engine is driving the clutch. This condition creates a hazardous situation due to the lack of vehicle control and due to the high clutch disc speed. Engaging the clutch under these conditions can cause component damage because of the shock loads to the clutch and drivetrain.

WARNING

Always shift into the gear that is correct for the traveling speed of the vehicle and engage the clutch. Coasting with the clutch disengaged can prevent engagement of the correct transmission gear which can cause loss of vehicle control, possibly resulting in personal injury or property damage.

High clutch disc speeds while coasting can also cause the clutch facing to be thrown off the disc. Flying debris from the clutch can cause injury to persons in the cab.

Clutch Maintenance

Checking the Clutch Adjustment

Report erratic clutch operation as soon as possible to give maintenance personnel a chance to inspect, lubricate, and adjust the clutch components. Notice any gradual decrease in the distance the clutch pedal moves before resistance is felt.

NOTICE

Operating the vehicle with incorrect free pedal could result in clutch damage.

A correctly adjusted clutch must have about 3/4 inch (19 mm) of travel at the top of its stroke before a stronger resistance can be felt. See [Fig. 14.4](#). If the free pedal travel is less than this distance, have the clutch inspected.

Check the clutch free pedal travel daily and note it in the driver's report.

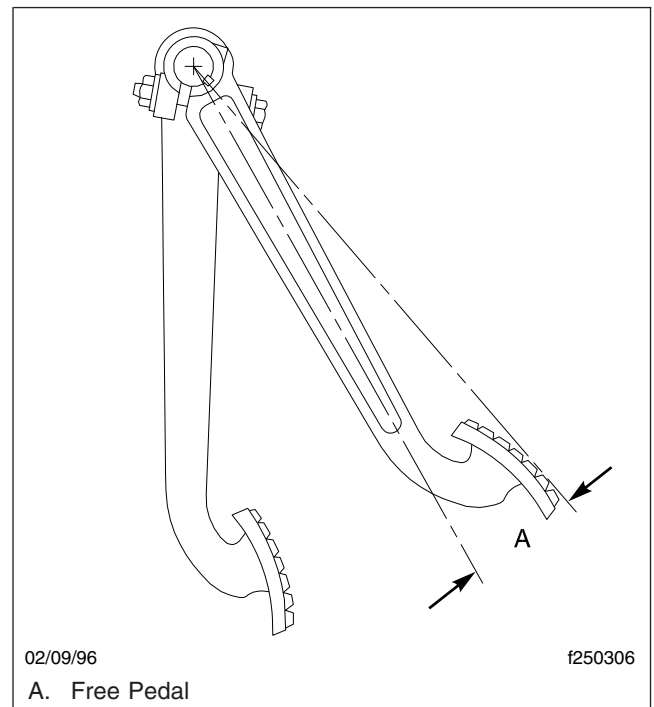

Fig. 14.4, Clutch Free Pedal Travel

Adjusting the Clutch

Clutches have an internal adjustment and external linkage adjustment. See **Group 25** of the *Century Class Trucks Workshop Manual* for clutch adjustment procedures and specifications.

NOTICE

Operating the vehicle with the clutch improperly adjusted could result in clutch or clutch brake failure.

Manual Transmissions and Clutch

Checking the Clutch Brake Operation

Clutch brake operation can be felt as an increased resistance as the clutch pedal approaches the bottom of its stroke. If the gears grind when shifting into first or reverse gear from neutral with the clutch pedal fully depressed, the clutch pedal is out of adjustment or the clutch brake is worn and needs to be replaced.

Lubricating the Clutch Release Bearing

NOTICE

Failure to lubricate the release bearing and linkage as recommended could result in release bearing and clutch damage.

On vehicles equipped with a greased release bearing, the release bearing should be lubricated at regular intervals. See the *Century Class Trucks Maintenance Manual* for intervals and procedures.

15

Automated Transmissions

Freightliner SmartShift Shift Control	15.1
Eaton Fuller UltraShift DM Transmission	15.1
Eaton Fuller UltraShift PLUS Transmission	15.6
Eaton Fuller AutoShift Transmission	15.10

Automated Transmissions

Freightliner SmartShift Shift Control

The Freightliner SmartShift transmission control is installed with all automated transmissions in the Argosy. It replaces the typical floor-mounted shift lever or dash-mounted push button control.

SmartShift accepts driver requests for transmission functions and transmits them through hard wiring to the transmission control unit (TCU). SmartShift is a true shift-by-wire system.

SmartShift offers two main advantages over conventional transmission control devices. Without a floor-mounted shift control, usable cab space is increased. The SmartShift control is operated by the fingers of the driver's right hand, allowing both hands to remain on the steering wheel.

A two-position driving mode slide switch allows the driver to choose automatic (AUTO) or manual (MAN) mode. See [Fig. 15.1](#).

In AUTO mode, gears shift automatically without driver interaction. Manual shifts are accomplished by a momentary pull or push on the control in the plane perpendicular to the steering wheel. Pull up (toward the driver) on the control to upshift and push down (away from the driver) to downshift. The control is spring-loaded and returns to its neutral position when released after an upshift or downshift.

A four-position gear selector switch is located at the end of the lever. See [Fig. 15.1](#).

A small neutral lock button is embedded in the gear selector switch to prevent accidental shifts into gear from neutral (N). Any time you shift through neutral, press down on the neutral lock button to move the switch from neutral to another gear, such as drive (D), low (L), or reverse (R). When shifting into neutral, it is not necessary to press the neutral lock button.

Eaton Fuller UltraShift DM Transmission

Refer to the Eaton website for additional information, www.roadranger.com.

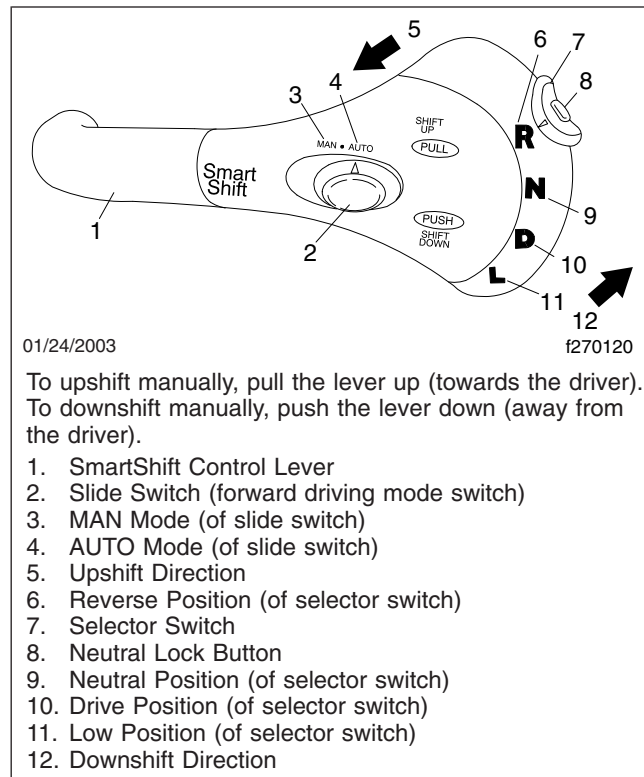

Fig. 15.1, Freightliner SmartShift Control

General Information, Ultrashift Transmission

Eaton Fuller UltraShift uses a dry clutch system which is offered only on this automated transmission system. The current gear is displayed on the indicator on the right-hand control panel. All forward shifts can be made either manually or automatically.

Operation, UltraShift Transmission Automatic and Manual Modes

The SmartShift control lever has a slide switch located on the body of the control lever just before the paddle widens out. See [Fig. 15.2](#). The slide switch controls the forward driving mode, automatic (AUTO) or manual (MAN).

To change mode at any time, move the slide switch in the desired direction. This allows the driver to respond to a wide range of driving conditions, such as blind corners, tight curves, and steep hills.

Automated Transmissions

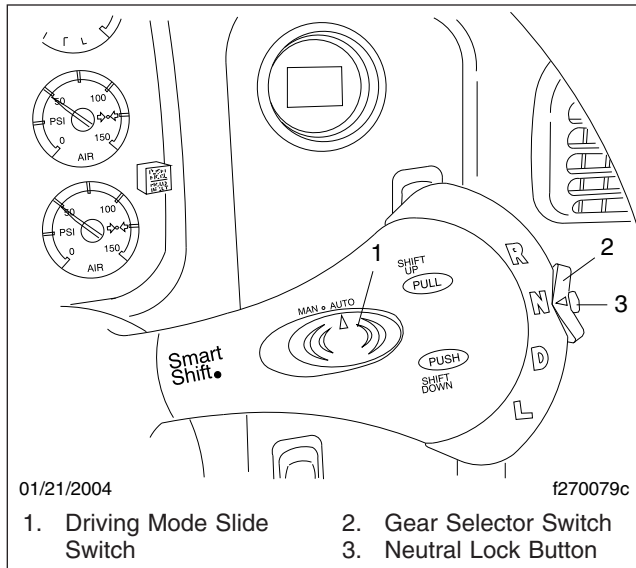

Fig. 15.2, Shift Controls and Indicators

IMPORTANT: In either mode, it is possible to shift manually by moving the lever up or down as needed. When the engine speed is within 75 rpm of the load-based shift point for an automatic shift, the TCU will advance the shift.

In either mode, the gear indicator displays the current gear. See [Fig. 15.3](#).

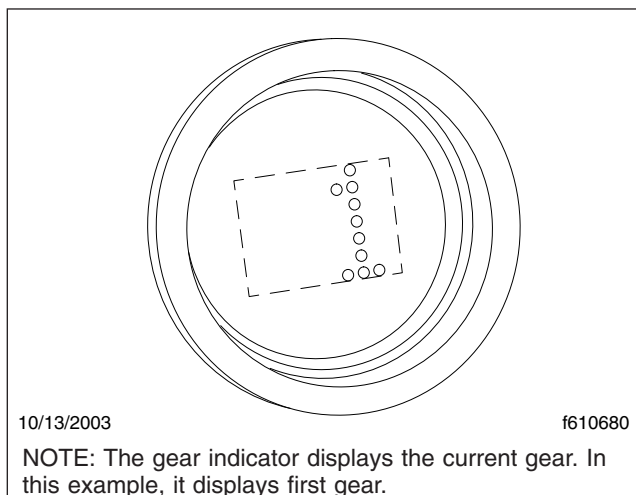

Fig. 15.3, Gear Indicator: Current Gear

At the start of a shift, the current gear continues to display until the transmission has been pulled into neutral. As the transmission is synchronizing for the

new (target) gear, the gear indicator flashes the number of the target gear.

When the shift is complete, the gear indicator displays the new gear, without flashing.

Automatic Mode (AUTO)

In automatic drive mode (AUTO), upshifts and downshifts are made by the transmission without driver intervention. Press the neutral lock button, move the gear selector switch to drive (D), and depress the accelerator pedal. The transmission will shift automatically.

If driving conditions require, it is still possible to request a manual shift. The transmission will make the shift if the engine speed is within 75 rpm of the load-based shift point for that gear.

If the driver depresses the accelerator pedal after a manual downshift in automatic mode, the transmission will upshift again if the TCU requires it.

Manual Mode (MAN)

In manual drive mode (MAN), upshifts and downshifts are made by the driver.

- To upshift, pull the lever up (towards the driver).
- To downshift, push the lever down (away from the driver).

The system will hold the current gear until the driver requests a shift. In downhill situations in particular, the driver must be alert to vehicle speed by downshifting and/or using the service brakes as needed.

A shift request will be refused if the selected gear would cause engine overspeed or excessive lugging.

Start Up

1. With the parking brake set, select neutral (N) by moving the gear selector switch to the N position.
2. Turn on the ignition switch. The CHECK TRANS and TRANS TEMP lamps illuminate and go out again (bulb check).

The gear indicator shows the dot display, arranged in a square pattern. All dots in the pattern should illuminate, without gaps or spaces. See [Fig. 15.4](#).

Automated Transmissions

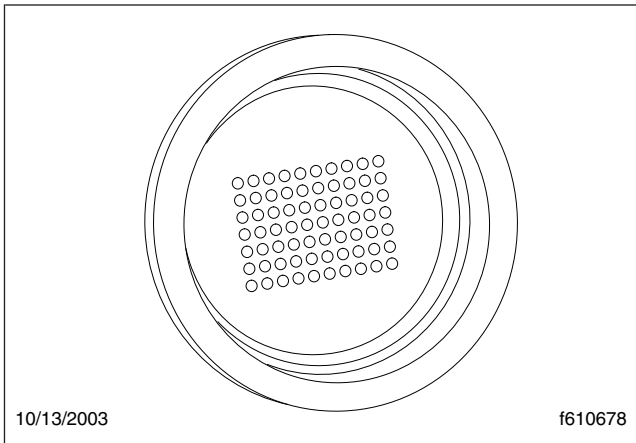

Fig. 15.4, Gear Indicator: Engine Start Up Dot Display

3. Wait for the gear indicator to show a solid N. See [Fig. 15.5](#). When the N is solid (not flashing), the TCU is powered up. Apply the service brake and start the engine.

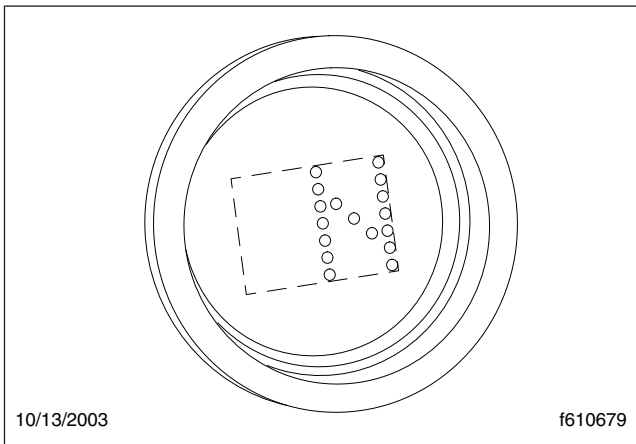

Fig. 15.5, Gear Indicator: Neutral

NOTE: When D is selected, the TCU starts in second gear. If desired, the driver can select to start in first. No other start gear is available.

4. Press the neutral lock button and move the gear selector switch forward to the D position below neutral. The current gear is displayed on the gear indicator.
5. Release the parking and service brakes and depress the accelerator pedal to allow the vehicle to move forward. The vehicle will not move until the pedal is depressed.

Hills and Grades

WARNING

When starting or stopping on hills and grades, use extra care to prevent the vehicle from rolling back. A rollback accident could cause death, serious personal injury, or property damage.

Prevent the vehicle from rolling backwards when stopped on a hill or grade, or when the vehicle is starting from a stop on a hill or grade. *To start from a full stop on a hill or grade*, quickly move your foot from the brake pedal and depress the accelerator pedal firmly. On steep hills, set the parking brake, and release it only when there is enough engine power to prevent rollback.

To stop on a hill or grade, depress and hold the brake pedal to keep the vehicle from moving. When parking, chock the tires, front and/or rear.

NOTICE

Never hold a hill with the accelerator pedal. Operating the vehicle too long between engine idle and 1000 revolutions per minute (rpm) during takeoff will cause the clutch to overheat.

Selecting Gears

Neutral

IMPORTANT: Always start the engine with the transmission in neutral (N), the parking brake set, and the service brakes applied.

N is located directly below R on the four-position gear selector switch on the SmartShift control lever. To select N, move the gear selector switch to the position below R. When neutral is selected, the letter N displays on the gear indicator. See [Fig. 15.5](#).

WARNING

Do not coast in neutral. Coasting in neutral can cause an accident, possibly resulting in severe personal injury or death.

Neutral is always available during operation, whatever the vehicle speed. When in neutral, requests to upshift or downshift are ignored. If the gear selector switch is moved from N to D while the vehicle is

Automated Transmissions

moving, the transmission will shift into a gear within the engine's operating speed range.

When shifting from neutral, always depress the brake pedal. If the brake pedal is not pressed, the transmission will not shift, the current gear display will flash N, and an audible alert will sound. To reset the transmission, return the gear selector switch on the SmartShift lever to N and attempt the shift again, this time with the brake pedal pressed.

Before shutting down the engine, return the gear selector switch to N. When the ignition is turned off, the transmission will reset to neutral in a few minutes regardless of the position of the gear selector switch.

Drive

Drive (D) is located directly below N on the four-position gear selector switch on the SmartShift control lever. To select D, press in the neutral lock button and move the gear selector switch to the position below N. When D is selected, the number of the currently selected forward gear displays on the gear indicator. See [Fig. 15.3](#).

When in drive, requests to upshift or downshift are enabled. Either manual or automatic mode can be selected on the slide switch.

The default starting gear is second, but first can be selected by the driver, if desired. To change the starting gear, depress the brake pedal and select D with the vehicle stopped. The gear indicator will display the starting gear. Move the control lever up or down until the desired starting gear is displayed.

The TCU adapts to the working conditions of each vehicle and its driver. After engine start up or a load change, it needs to learn the new conditions. While learning, it may hold a gear too long before upshifting. Start the upshift manually. It may take three or four shifts before UltraShift succeeds in learning the new load-based shift points, but after that it will handle the shifting automatically.

Reverse

Reverse (R) is located at the upper end of the four-position gear selector switch on the SmartShift control lever. To select R, press in the neutral lock button and move the gear selector switch up to the position above neutral.

The UltraShift transmission has two reverse gears: Reverse Low (RL) and Reverse High (RH). To shift

manually between them, use the control lever as described for MAN mode. There is no AUTO mode for reverse.

When Reverse Low is selected, the letter R displays on the gear indicator. When Reverse High is selected, the letter H displays on the gear indicator. See [Fig. 15.6](#).

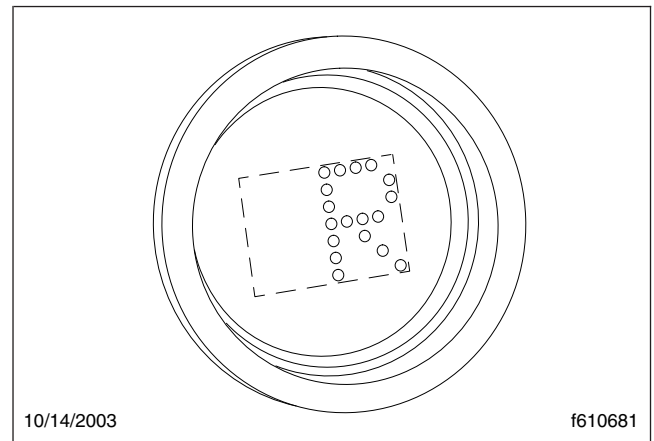

Fig. 15.6, Gear Indicator: Reverse Low Gear

IMPORTANT: Under normal conditions, do not select reverse with the vehicle moving forward.

The vehicle must be moving at less than two miles per hour (3 km/h) before selecting reverse. If reverse is selected when the vehicle is moving faster, an audible alert will sound and continue sounding at three-second intervals until the gear selector switch is returned to the D position or the vehicle slows to the proper speed.

If necessary to rock the vehicle, use the gear selector switch to shift back and forth at low speed between reverse and drive.

Low

Low (L) is located at the lower end of the four-position gear selector switch on the SmartShift control lever. To select L, press in the neutral lock button and move the gear selector switch to the position below D.

When in low, the current gear is maintained. Requests to upshift are not enabled.

IMPORTANT: If the engine is approaching over-speed, the TCU will override the current gear setting and upshift to prevent engine damage.

Automated Transmissions

To enhance engine braking, downshifts are performed at higher rpm than normal.

If L is selected from neutral while stopped, the vehicle starts in first gear and stays there until the engine approaches overspeed.

Upshifting

To request an upshift with the transmission in drive, pull the control lever up (towards the driver). If the gear is available, the transmission will upshift and the new gear will display on the gear indicator. Skip shifts are not available while upshifting. Upshifts are not available in low, except to prevent engine overspeed.

If the transmission does not upshift quickly enough after engine start up or a load change, begin the shift manually. The TCU will learn the new load-based shift conditions after three or four shifts.

If the gear requested is unavailable, a tone will sound. An unavailable request to upshift is not stored in memory; the upshift must be requested again.

Downshifting

To request a downshift with the transmission in drive or low, push the control lever down (away from the driver). If the gear is available, the transmission will downshift and the new gear will display on the gear indicator. Skip shifts are available while downshifting.

For best engine braking, select low while moving. In low, downshifts are performed at higher rpm than in drive.

IMPORTANT: If the engine is approaching overspeed, the TCU will override the current gear setting and upshift to prevent engine damage.

If the gear requested is unavailable, a tone will sound. An unavailable request to downshift is not stored in memory; the downshift must be requested again.

When coasting to a stop, the TCU may not finish the downshift until the driver depresses the accelerator pedal again.

IMPORTANT: A downshift request can never result in a shift into neutral, even if the vehicle is in the drive position in the lowest possible gear.

Before starting down a hill, slow down. Downshift to a speed that you can control without hard pressure on the service brakes.

Before entering a curve, slow down to a safe speed. Downshift if necessary. This lets you use some power through the curve to help the vehicle be more stable on the turn. It also allows you to regain speed faster as you come out of the curve.

Shutdown

1. Apply the service brakes.
2. Move the gear selector switch to the N position. When the N on the gear indicator is solid (not flashing), the TCU is ready to shut down.
3. Set the parking brake.
4. Turn off the ignition key and shut down the engine.

Ultrashift Diagnostics

Clutch Protection Fault

Even though a vehicle with an UltraShift transmission does not have a clutch pedal, it does have a mechanical clutch. As you slowly increase and decrease engine rpm from a stop, the mechanical clutch is engaging and disengaging, just like slipping the clutch with a manual transmission. Excessive clutch slippage creates heat and reduces the life of the clutch. These are some conditions which can cause clutch damage:

- Using the accelerator to hold the vehicle on a hill
- Starting the vehicle from a stop in a gear that's too high
- Overloading the vehicle
- Using high idle with the vehicle in gear

The TCU is programmed to prevent clutch damage. When the clutch overheats, the following alerts take place:

- The TRANS TEMP light comes on
- The gear indicator displays "C," then "A"
- A warning tone sounds at one-second intervals

The alerts continue until the clutch cools, the accelerator is released, or the clutch is fully engaged.

System Problem

In the event of a problem, complete the following steps.

1. Note the driving conditions at the time the problem occurred.
2. Record the status of the transmission at the time of the problem (AUTO or MAN mode, gear setting, current gear, engine speed, etc.).
3. Complete the transmission reset procedure.

Transmission Reset Procedure

In some cases, proper transmission operation can be restored by resetting the TCU. Use the following procedure to reset the TCU.

1. When it is safe to do so, stop the vehicle.
2. Select N by moving the gear selector switch to N.
3. Set the parking brake.
4. Shut down the engine.
5. Wait at least two minutes.
6. Restart the engine.
7. If the problem continues or the transmission doesn't achieve neutral after engine start up, contact an authorized Freightliner or Eaton service facility.

Locked In Gear

If the vehicle is shut down in gear, the transmission may become locked in gear. The transmission will attempt to get to neutral during the next engine start up if the gear selector switch is positioned on N. If neutral can't be achieved, a dash (–) will appear on the gear indicator when the vehicle is restarted.

NOTE: If the transmission becomes locked in gear while the vehicle is moving, increased braking effort may be required to stop the vehicle.

If the gear indicator displays a dash during engine start up with the gear selector switch in neutral, complete the following steps.

1. Make sure the parking brake is set.
2. Turn off the ignition and wait at least two minutes.

3. Depress the brake pedal and release the parking brake.
4. Make sure the gear selector switch is positioned on N, then turn on the ignition key. Do not attempt to start the engine yet.
5. If necessary to get the transmission to shift into neutral, release the pressure on the brake pedal slightly.
6. Once the TCU reaches neutral, a solid N will appear on the gear indicator and the vehicle will start. Apply the service brakes and start the engine.
7. If the gear indicator continues to display a dash, contact an authorized Freightliner or Eaton service facility.

Eaton Fuller UltraShift PLUS Transmission

Refer to the Eaton website for additional information, www.roadranger.com.

Eaton Fuller UltraShift PLUS automated transmissions use shift selection software and electric clutch actuation; a clutch pedal is not needed to operate the vehicle. The current gear is displayed on the indicator on the right-hand control panel. All forward shifts can be made either manually or automatically.

Engine Start Up

NOTE: Engine cranking is delayed until the transmission power-up is complete and the gear display shows a solid "N".

1. With the parking brake set, turn the ignition switch to the ON position.
2. Start the engine.
3. Apply the service brake.

NOTE: If the service brake is not applied while selecting a starting gear, the initial start gear will not be found and the driver will need to select Neutral and depress the service brake while selecting the desired mode.

4. Select the desired mode and starting gear. (Inappropriate start gear selections are ignored to avoid damaging the transmission.)

Automated Transmissions

5. Release the parking brake.
6. Release the service brake and apply the accelerator.

Engine Shutdown

1. Select Neutral on the shift control.

NOTE: If the gear display does not show a solid "N", neutral has not yet been obtained. Neutral should always be reached before powering down an UltraShift PLUS, except in cases of emergency.

2. Set the parking brake.
3. Turn off the ignition, and shut down the engine.

Reverse

NOTE: If attempting to select a non-Neutral mode without applying the service brakes, the transmission will not shift into gear. To shift into gear, select Neutral, apply the service brakes, and select the desired mode again. Also, the vehicle will not engage reverse above 2 mph (3 km/h).

Reverse (®) is at the upper end of the four-position selector switch located at the end of the SmartShift control. To select R, press in the neutral lock button and move the selector switch to the position above neutral. The default Reverse gear is engaged.

NOTICE

Avoid launching the vehicle in high range. Launching the vehicle in high range increases the likelihood of clutch abuse and could be detrimental to clutch life.

Automatic Mode (AUTO)

In automatic drive mode (AUTO), upshifts and downshifts are made by the UltraShift PLUS without driver intervention. Press in the neutral lock button, move the selector switch to Drive (D), and depress the accelerator pedal. The transmission will shift automatically.

NOTE: If attempting to select a non-Neutral mode without applying the service brakes, the transmission will not shift into gear. To shift into

gear, select Neutral, apply the service brakes, and select the desired mode again.

In Drive, the start gear is automatically selected. The selected start gear can vary depending on several vehicle inputs such as load, grade, and axle/transmission ratio. The start gear can be changed using the SmartShift control, provided the selected gear would allow the vehicle to launch without damaging the transmission. If the start gear is changed using the SmartShift control, it will be the default until the vehicle is powered down or the selection is changed again manually.

IMPORTANT: Prior to ascending a steep grade, either reduce the default start gear by one (using the SmartShift control) or apply full throttle for the duration of the grade so the vehicle maintains the proper engine and vehicle speed during the entire grade.

In Drive, the transmission automatically performs upshifts and downshifts. However, when the transmission is near the shift point, the shift can be forced using the upshift or downshift function of the SmartShift control.

NOTE: The transmission may deny a shift while ascending or descending a grade if the load of the vehicle and grade of the terrain in combination with the drivetrain ratio and engine torque fall outside of the acceptable range to perform a shift. If the shift is denied, a tone will sound.

Manual Mode (MAN)

In manual mode (MAN), the driver selects upshifts and downshifts instead of letting the UltraShift PLUS select them automatically. Manual shifting may be helpful when traversing a work site, railroad tracks, or steep grades, for example. To drive forward, press in the neutral lock button, move the selector switch to Drive (D), and depress the accelerator pedal. To upshift, pull the lever up (towards you); to downshift, push the lever down (away from you). The system holds the current gear unless a shift is requested or if the system initiates a manual mode override.

NOTE: The transmission may deny a shift while ascending or descending a grade if the load of the vehicle and grade of the terrain in combination with the drivetrain ratio and engine torque

fall outside of the acceptable range to perform a shift. If the shift is denied, a tone will sound.

NOTE: If attempting to select a non-Neutral mode without applying the service brakes, the transmission will not shift into gear. To shift into gear, select Neutral, apply the service brakes, and select the desired mode again.

Manual Mode Override

The system is equipped with a manual mode override function. If the vehicle is being "back driven" (for example, descending a grade and vehicle speed exceeds engine speed) and the engine speed is excessively high, the system will upshift automatically. Also, if the start gear is changed and it causes the engine to lug at takeoff, the system will override the current position and select the best available gear.

Low (L)

Low (L) is at the lower end of the four-position selector switch located at the end of the SmartShift control. Use Low when wanting to maximize engine braking and minimize the use of the brake pedal—for example, when driving down long grades or when coming to a stop. To select Low, press in the neutral lock button and move the selector switch to the L position. The lowest available start gear will be selected (the starting gear cannot be changed in Low).

If Low is selected while moving, the transmission will not upshift (unless the system initiates a Low override). The system will downshift at the earliest opportunity to provide maximum engine braking.

NOTE: If attempting to select a non-Neutral mode without applying the service brakes, the transmission will not shift into gear. To shift into gear, select Neutral, apply the service brakes, and select the desired mode again.

Low Override

The system is equipped with a Low override function. If the vehicle is being "back driven" (for example, descending a grade and vehicle speed exceeds engine speed) and the engine speed is excessively high, the system will upshift automatically. Also, if the start gear is changed and it causes the engine to lug at takeoff, the system will override the current position and upshift.

Clutch Abuse Protection

Although a vehicle equipped with an UltraShift PLUS uses an automated clutch, the clutch can still overheat and slip with improper use. The clutch abuse protection feature helps protect the clutch if the automated clutch starts to overheat. When the clutch abuse protection feature initiates and sounds a warning tone, full clutch actuation must be completed quickly. If it is not completed quickly enough, the system will either open the clutch (if the accelerator pedal is not being pressed) or close the clutch (if the accelerator pedal is being pressed). If the abuse continues, the system will open the clutch and take away throttle control briefly to allow the clutch to cool down.

To protect the clutch:

- Select the lowest possible start gear for the application.
- Use Creep Mode when appropriate.
- Use the service brakes and the Hill Start Aid when launching on a grade.
- Minimize the time it takes to engage the clutch from rest.
- Do not use the throttle to hold the vehicle on a grade; use the service brakes.
- Do not use the throttle to stop roll back on an incline after Hill Start Aid disengages; use the service brakes, and then relaunch.
- Do not continually start and stop, especially when loaded; use a lower gear or Creep Mode.

Creep Mode

The Creep Mode function allows the vehicle to maintain a constant speed at engine idle without the driver holding the accelerator pedal position. This mode is useful for very low-speed maneuvering and applications where steady vehicle speed is required. The vehicle speed is determined by the selected gear ratio operating at governed low engine idle speed. Any available gear may be selected, though the transmission will downshift or exit Creep Mode to prevent stalling if the engine lugs due to load conditions.

Automated Transmissions

By default, Creep Mode can be activated while in Manual Mode or Low. Eaton's ServiceRanger diagnostic software can be used to enable Creep Mode in Automatic Mode and/or Reverse.

Engaging Creep Mode

To engage Creep Mode:

1. Select Low or Manual Mode and the desired gear (while stopped or moving).
2. Apply the accelerator pedal to accelerate the vehicle until the clutch is closed (engaged).
3. Release the accelerator pedal. The vehicle will continue moving at governed low engine idle speed.

Exiting Creep Mode

To exit Creep Mode, apply the accelerator pedal to accelerate temporarily, or select a higher gear in Manual Mode. (Creep Mode can be resumed in the selected gear by releasing the accelerator pedal.)

NOTE: The transmission will exit Creep Mode if the engine lugs 150 rpm below the governed low engine idle speed. In this case, a lower gear should be selected if available.

Hill Start Aid

UltraShift PLUS transmissions are equipped with a Hill Start Aid (HSA) feature to prevent the vehicle from rolling while on grades steeper than 3% and allow for a controlled launch. A grade sensor is used to determine when to engage the feature.

HSA is "on" by default. It can be turned off by pressing and releasing the override switch on the dash (see [Chapter 5](#)). HSA will turn back on after the first successful launch.

When the vehicle is stopped on a grade greater than 3% and in a forward mode or reverse, depress the service brakes then release them. The vehicle will begin to move after 3 seconds, and the clutch will perform partial engagements to slow the vehicle motion. Either step on the brake or apply the throttle to continue negotiating the grade.

Engine Overspeed Protection

The system will upshift if necessary to prevent engine overspeed in Drive, Manual, and Low.

Shuttle Shifting

Shuttle shifting from reverse to any forward mode is only allowed if the vehicle speed is approximately zero.

Auto Start Gear Selection and Override

The UltraShift PLUS system uses various inputs to automatically select the best start gear in Drive and Manual. This selection can be changed using the SmartShift control; however, if the selection requested could cause damage or engine lugging, the request will be denied and a tone will sound.

Skip Shifting

When appropriate, the UltraShift PLUS system may skip shift in Drive. When prevailing conditions like load and grade allow, skip shifts can be performed in Manual mode using the SmartShift control.

Auto Neutral

The UltraShift PLUS system will automatically shift to neutral if the vehicle is left in Drive and the parking brake is set. "AN" will show on the gear display. To re-engage the transmission, select Neutral and then either Drive or Reverse on the shift control (it will re-engage regardless of whether the parking brake is released).

Automatic Traction Control

The UltraShift PLUS system requires the Automatic Traction Control (ATC) option to be enabled when driving in soft soil/sand to prevent wheel slippage and shifting issues. The ATC system has two modes: "normal" (for sand and loose road surface) and a mud/snow setting.

ATC Normal Mode

In normal mode, the system will engage the brakes on the wheel or side that the wheel slip is occurring to help the vehicle gain traction. The point at which the traction control will actuate the braking system increases with throttle: low throttle allows the system to brake the wheels earlier; heavy/full throttle raises the point of the acceptable wheel slip.

Adhere to the following points when driving in ATC normal mode:

- If using Automatic mode in soft soil and/or sand, maintain the engine speed between 1000 and 1300 rpm to prevent unnecessary upshifting.
- If using Manual mode in soft soil and/or sand, do not attempt an upshift and try to maintain the current gear.
- If the vehicle comes to a stop in the sand it may be necessary to back up prior to attempting forward movement.

ATC Mud/Snow Mode

To select the mud/snow mode, depress the ATC switch (see [Chapter 5](#)). This mode raises the wheel slip speed that is allowed before the traction control activates. The point at which the traction control will actuate the braking system increases with throttle: low throttle allows the system to brake the wheels earlier; heavy/full throttle raises the point of the acceptable wheel slip.

Load-Based Shifting

The UltraShift PLUS system is adaptive and will change the shift points based on grade, engine RPM, throttle position, and vehicle load. After changing loads or powering up, the system needs to relearn these inputs for the first few shifts to make the proper adjustments.

Coasting

When coasting to a stop on level terrain, the UltraShift PLUS system may not downshift into the lower gears. It will select a gear after the throttle is applied.

Eaton Fuller AutoShift Transmission

Refer to the Eaton website for additional information, www.roadranger.com.

General Information, AutoShift Transmission

Eaton Fuller AutoShift transmissions have ten or eighteen forward speeds and two reverse speeds. The driver must use the clutch to start and stop the vehicle. However, the driver does not need to use the clutch to shift gears. The transmission signals the

engine controller when to break torque and the engine controller automatically increases or decreases engine speed. When engine speed is correct, the transmission engages the next gear and signals the engine controller to resume operation.

Operation, AutoShift Transmission

Automatic and Manual Modes

The SmartShift control lever has a slide switch controls the forward driving mode, automatic (AUTO) or manual (MAN). See [Fig. 15.2](#).

To change mode at any time, move the slide switch in the desired direction. This allows the driver to respond to a wide range of driving conditions, such as blind corners, tight curves, and steep hills.

In either mode, the gear indicator displays the current gear. See [Fig. 15.3](#).

At the start of a shift, the current gear continues to display until the transmission has been pulled into neutral. As the transmission is synchronizing for the new (target) gear, the gear indicator flashes the number of the target gear.

When the shift is complete, the gear indicator displays the new gear, without flashing.

Automatic Mode

In automatic drive mode, upshifts and downshifts require no driver interaction. Press in the neutral lock button, move the gear selector switch to drive (D), depress the clutch to engage the gear selected, release the clutch, and depress the accelerator pedal. The transmission will shift automatically based on vehicle and transmission conditions.

If the vehicle is stopped while in drive, pull up or push down on the SmartShift control lever to change the starting gear.

If driving conditions require, it is possible to request a manual shift. The transmission will make the shift if the engine speed is within 75 rpm of the load-based shift point for that gear.

Manual Mode

In manual drive mode (MAN), upshifts and downshifts are made by the driver. Manual mode should be used whenever you want to select the shifts instead of letting the transmission shift automatically.

Automated Transmissions

To upshift, pull the lever up (towards the driver). To downshift, push the lever down (away from the driver). The system will hold the current gear until the driver requests a shift. In downhill situations in particular, the driver must be alert to vehicle speed by downshifting and/or using the service brakes as needed.

A shift request will be refused if the selected gear would cause engine overspeed or excessive lugging.

If the vehicle is stopped while in drive, pull up or push down on the SmartShift control lever to change the starting gear.

Engine Start Up

1. With the parking brake set, select neutral (N) by moving the gear selector switch to the N position.
2. Depress the clutch pedal all the way down to the floor.
3. Start the engine. The CHECK TRANS and TRANS TEMP lamps illuminate and go out again (bulb check).
4. Release the clutch to allow the speed sensor on the input shaft to get a reading.
5. Depress the clutch again and release the parking and service brakes.
6. Select the desired starting gear.
7. Release the clutch.

Selecting a Starting Gear

1. In automatic mode, select drive (D) by sliding the gear selector switch downward to the next position below the neutral position.
2. Depress the clutch to engage the gear selected. Release the clutch and drive the vehicle.

Changing the Default Starting Gear

To select a starting gear other than the default starting gear, follow the instructions below.

1. Make sure the vehicle is stopped and in drive.
2. In either automatic or manual mode, pull upward (to increase) or push downward (to decrease) on the SmartShift control lever. Each pull upward on the control increases the starting gear by one gear, but no higher than fourth gear.

3. The number of the gear selected will flash on the gear indicator until the driver releases the clutch. This gear will be stored in memory as the default starting gear until either a different starting gear is selected by the driver or the engine is shut down.

NOTE: The transmission may also be programmed so that it is not possible to select a starting gear other than the preprogrammed default starting gear.

Upshifting

NOTE: With the transmission in drive in the automatic mode, upshifts require no driver interaction.

1. With the transmission in drive in the manual mode, pull the control lever up (towards the driver) to upshift. If the requested gear is available, the transmission will upshift and the new gear will display on the gear indicator.

NOTE: Two consecutive, momentary upward pulls will cause a skip shift when the next two higher gears are available and conditions are appropriate.

2. To skip shift, move the control twice in less than 1/2-second. The number of the gear engaged will appear on the gear indicator.

NOTE: The Eaton Fuller AutoShift transmission is able to perform triple upshifts when the next three higher gears are available and conditions are appropriate. To triple-shift, move the control three times in less than 1/2-second.

If the gear requested is unavailable, a tone will sound. An unavailable requested upshift is not stored in memory; the upshift must be requested again.

Downshifting

NOTE: With the transmission in drive in the automatic mode, downshifts require no driver interaction.

1. With the transmission in drive in the manual mode, push the control lever down (away from the driver) to downshift. If the requested gear is available, the transmission will downshift.

NOTE: Two consecutive, momentary downward pushes will cause a skip shift, when the next two lower gears are available and conditions are appropriate.

2. To skip shift, move the control lever two times in less than ½-second. The number of the gear engaged will appear on the gear indicator.

NOTE: The Eaton Fuller AutoShift transmission is able to perform triple downshifts when the next three lower gears are available and conditions are appropriate. To triple shift, move the control lever three times in less than ½-second.

If the gear requested is unavailable, a tone will sound. An unavailable requested downshift is stored in memory and the shift will be made when the gear is available. The time limit for this memory is a programmable parameter.

Neutral

N is located directly below R on the four-position gear selector switch on the SmartShift control lever. To select N, move the gear selector switch to the position below R. When neutral is selected, the letter N displays on the gear indicator. See [Fig. 15.5](#).

NOTE: Neutral is always available during operation. When in neutral, upshift and downshift requests are ignored. If the gear selector switch is moved from neutral (N) to drive (D) while the vehicle is moving, the transmission will shift into the gear that is appropriate for the road speed of the vehicle.

Drive

Drive (D) is located directly below N on the four-position gear selector switch on the SmartShift control lever. To select D, press the neutral lock button and move the gear selector switch to the position below N. When D is selected, the number of the currently selected forward gear displays on the gear indicator. See [Fig. 15.3](#).

When in drive, requests to upshift or downshift are enabled. Either manual or automatic mode can be selected on the slide switch.

Reverse

Reverse is located at the upper end of the four-position gear selector switch on the SmartShift control lever. To select reverse, press the neutral lock

button and move the gear selector switch upward to the position above neutral and depress the clutch pedal.

NOTE: AutoShift transmissions have a dual-range reverse. Reverse Low (RL) is the default reverse gear.

Select Reverse High (RH) by pulling upward on the SmartShift control lever. When Reverse Low is selected, the letter R displays on the gear indicator. When Reverse High is selected, the letter H displays on the gear indicator. See [Fig. 15.6](#).

NOTE: Reverse may be engaged below a programmable forward speed in order to rock the vehicle. If reverse is selected above the programmed forward speed, an audible warning will sound indicating that the gear is not available.

Low Gear Operation

Use low (L) to maximize engine braking and minimize the use of the brake pedal. It is most useful when descending steep hills or when coming to a stop. Engine speed will be increased by 200 rpm and shift points will be offset by 200 rpm. The efficiency of the exhaust brake will be maximized.

Low (L) is located at the lower end of the four-position gear selector switch on the SmartShift control lever. To select L, press the neutral lock button and move the gear selector switch to the position below D.

16

Drive Axle Feature Operation

Differential Lock	16.1
Interaxle Lock	16.2

Drive Axle Feature Operation

Differential Lock

The driver-controlled differential lock feature (side-to-side wheel lock, traction control, or traction equalizer) provides maximum traction for slippery conditions by forcing the wheels on each drive axle governed by the switch to rotate together. When the differential lock is engaged, the clutch collar completely locks the differential case, gearing, and axle shafts together, maximizing the traction of both wheels.

Differential Lock Switches

There are several differential lock options available:

- a switch to control the differential lock on the forward drive axle.
- a switch to control the differential lock on the middle drive axle.
- a switch to control the differential lock on the rearmost drive axle (see Fig. 16.1, Item 3).

Differential Lock Operation

NOTE: On some vehicles, the differential lock system is connected through the low speed range of the transmission. If this system is used, the transmission must be in the low speed range for the wheels to fully lock. In addition, shifting out of low speed range will also disengage the differential lock.

WARNING

Locking the wheels when the vehicle is traveling down steep grades or when the wheels are slipping could damage the differential and/or lead to loss of vehicle control, causing personal injury and property damage.

NOTICE

Engage the differential lock only when the vehicle is stopped or moving at less than 5 mph (8 km/h). Engaging the differential lock at high speeds can cause internal axle damage.

1. With the engine running, move the differential lock switch to LOCK to engage the differential lock.

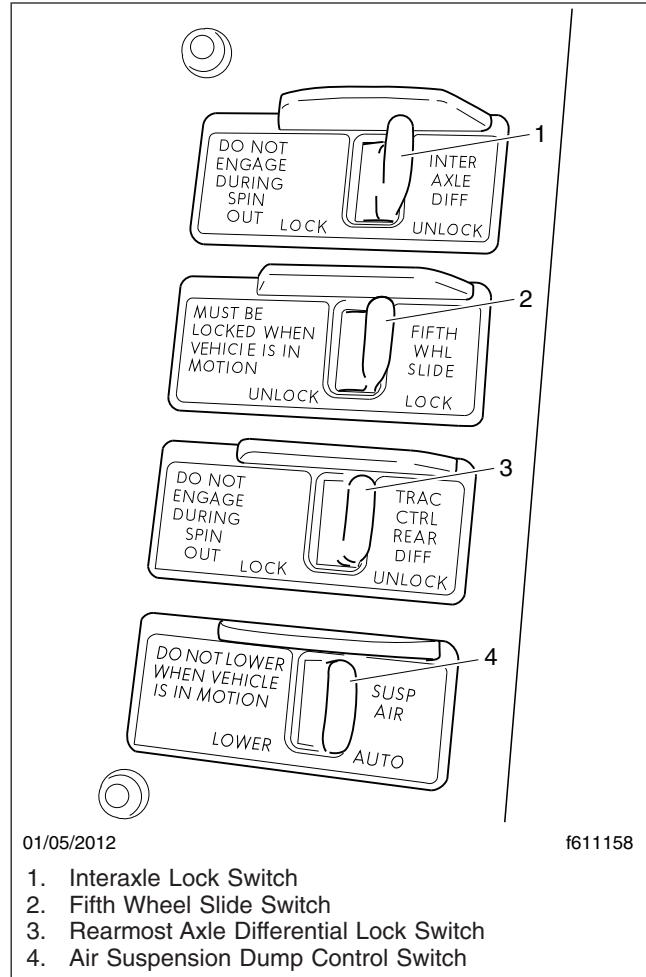

Fig. 16.1, Axle and Suspension Switches

2. If the vehicle is moving, briefly let up on the accelerator to relieve torque on the gearing, allowing the differential to fully lock.

WARNING

Be especially careful when driving under slippery conditions with the differential locked. Though forward traction is improved, the vehicle can still slip sideways, causing possible loss of vehicle control, personal injury, and property damage.

3. Drive cautiously and do not exceed 25 mph (40 km/h). When the differential is fully locked, the turning radius will increase because the vehicle understeers. See Fig. 16.2.

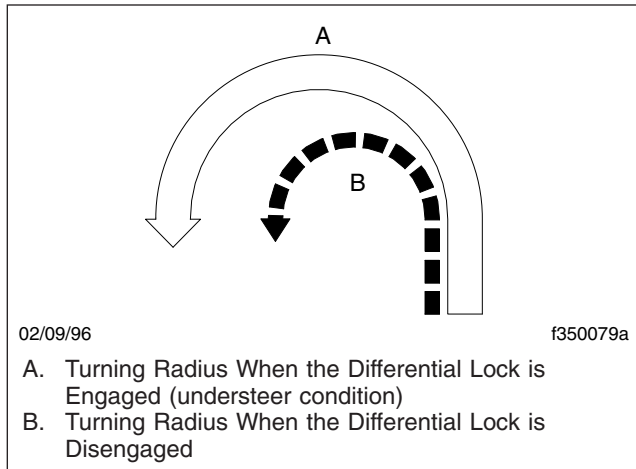

Fig. 16.2, Turning Radii

4. Move the differential lock switch to UNLOCK to disengage the differential lock after leaving poor road conditions.

NOTE: If the differential lock is engaged when the engine is shut down, the differential lock will disengage.

5. If the vehicle is moving, briefly let up on the accelerator to allow the wheels to fully unlock, then resume driving at normal speed.

Interaxle Lock

The interaxle lock (axle lock, interaxle differential lockout) feature is available on vehicles with tandem- or tridem-drive axles. The interaxle lock causes the drive axle shafts to rotate together, and is recommended for use under adverse road conditions where greater traction is needed. Do not wait until traction is lost and the tires are spinning before engaging the interaxle lock.

See the axle manufacturer's website for more information.

When engaged, the interaxle lock essentially makes the driveshaft a solid connection between the drive axles. Power entering the forward drive axle is transmitted straight through to the rearmost axle(s). Driveline torque is now delivered equally and the drive axles, and wheels, turn together at the same speed. The interaxle lock increases drivetrain and tire wear and should be used only when improved traction is required.

Interaxle Lock Switch

The interaxle lock switch allows the driver to lock the drive axles together. See [Fig. 16.1](#), Item 1.

Interaxle Lock Operation

NOTICE

The interaxle lock should not be engaged on a vehicle with obviously spinning wheels. Engagement at high speed or power can damage the axle(s).

1. With the engine running, move the interaxle lock switch to LOCK to engage the interaxle lock.
2. If the vehicle is moving, briefly let up on the accelerator until the interaxle lock engages.

NOTICE

Do not operate the vehicle continuously with the interaxle locked during extended good road conditions. To do so could result in damage to the axle gearing and excessive driveline and tire wear.

3. Proceed over poor road conditions with caution.
4. Move the interaxle lock switch to UNLOCK to disengage the interaxle lock after leaving poor road conditions.
5. If the vehicle is moving, briefly let up on the accelerator to allow the interaxle lock to disengage, then resume driving at normal speed. Once the interaxle lock disengages, the indicator light will go off.

17

Fifth Wheels

Fifth Wheels, General Information	17.1
Fifth Wheel Coupling	17.1
Fifth Wheel Uncoupling	17.4
Fifth Wheel Slide	17.5

Fifth Wheels

Fifth Wheels, General Information

WARNING

Do not use any fifth wheel that fails to operate properly. Doing so may cause loss of vehicle control, possibly resulting in severe personal injury or death.

Air-Suspension Dump Valve

The air-suspension dump valve may be used to adjust the tractor height to aid with coupling to or uncoupling from a trailer. See [Fig. 17.1](#). When the switch is set to LOWER, the air-suspension dump valve deflates the air springs to lower the rear of the vehicle. In the AUTO position, the automatic ride-control valves operate for normal driving.

WARNING

Never exhaust air from the suspension while driving. The suspension will not absorb road shocks, possibly damaging components, and vehicle handling may be compromised. This could result in loss of vehicle control, possibly resulting in severe personal injury or death.

NOTICE

Do not operate the vehicle over uneven ground such as ramps, speed bumps, curbs, etc. with the air springs deflated. Doing this may lead to air bag separation from the piston, preventing the suspension air springs from inflating.

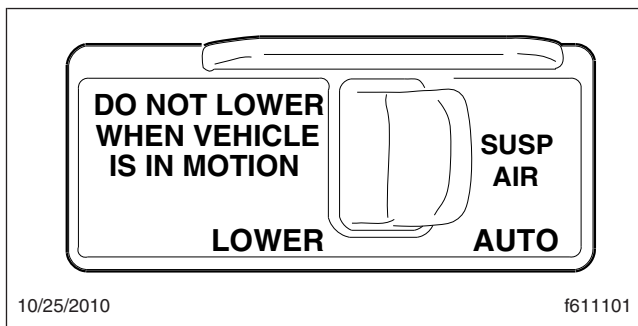

Fig. 17.1, Air-Suspension Dump Valve

Fifth Wheel Lubrication

WARNING

Keep the fifth wheel plate lubricated to prevent binding between the tractor and trailer. A binding fifth wheel could cause erratic steering and loss of vehicle control, possibly resulting in personal injury or death.

The standard fifth wheel plate must be kept well lubricated with chassis grease to prevent friction and binding between the tractor fifth wheel plate and the trailer.

For a low-lube fifth wheel plate, inspect the condition of the low-lube pads. There should be no damaged or missing pieces. Slight puckering at the outside edges is normal.

For lubrication instructions, see **Group 31** of the *Argosy Maintenance Manual*.

Fifth Wheel Coupling

Fifth wheel coupling is activated with the release handle located on either the right side or left side of the fifth wheel. Coupling has successfully occurred when the kingpin has been forced into the jaws and the release handle has moved to the locked position.

NOTICE

Some fifth wheels may be mounted on sliding rails. Before attempting to couple a trailer to a sliding fifth wheel, the slide feature must be locked to prevent the top plate from sliding rapidly forward or rearward, causing damage to the fifth wheel or kingpin.

Coupling, Fontaine or Holland Fifth Wheel

1. Chock the trailer tires.
2. Ensure the fifth wheel jaw is fully open and the release handle is in the unlocked position.
3. Make sure the fifth wheel top plate is tilted so the ramps are as low as possible.

- Position the tractor so that the center of the fifth wheel is in line with the trailer kingpin. The kingpin should be in a position to enter the throat of the locking mechanism.

NOTICE

Attempting to couple at the wrong height may cause improper coupling, which could result in damage to the fifth wheel or kingpin.

- Adjust the trailer height if required.

For a standard fifth wheel plate, the trailer should contact the fifth wheel approximately 4 to 8 inches (10 to 20 cm) behind the fifth wheel pivot. See [Fig. 17.2](#).

For a low-lube fifth wheel plate, the fifth wheel must slide freely under the trailer, and the trailer should contact the fifth wheel at the pivot. See [Fig. 17.3](#).

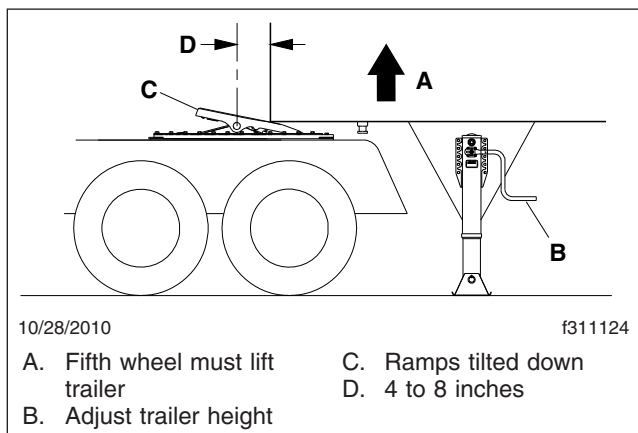

Fig. 17.2, Trailer Connection Point, Standard Fifth Wheel

- With the fifth wheel lock opening aligned with the trailer kingpin, back the tractor slowly toward the trailer. After sliding under the trailer, STOP to prevent from hitting the kingpin too hard, then resume backing slowly until the fifth wheel locks.

On a standard fifth wheel, the fifth wheel must lift the trailer.

On a low-lube fifth wheel, do not lift the trailer as this may damage the fifth wheel plate.
- Apply the tractor parking brakes.

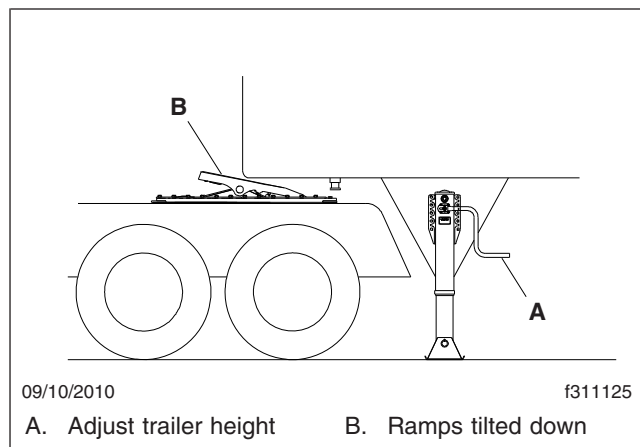

Fig. 17.3, Trailer Connection Point, Low-Lube Fifth Wheel

WARNING

A visual inspection is required by law. Some improper couplings can pass a pull test. Sound is not reliable. Get out of the cab and look. Incorrect coupling could cause the trailer to disconnect, possibly resulting in serious personal injury or death.

- Perform a coupling inspection, checking that there is no gap between the bottom of the trailer and the fifth wheel, and that the kingpin is securely locked. See [Fig. 17.4](#).

When the kingpin is locked securely, the fifth wheel release handle moves to the locked position. Make sure that the safety latch is down over the release handle to hold the release handle in the locked position (the safety latch will only rotate down if the control handle is fully retracted in the locked position).

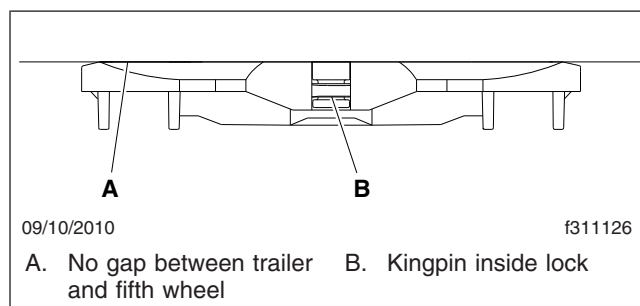

Fig. 17.4, Coupling Inspection

Fifth Wheels

- Release the tractor parking brakes. Test for kingpin lock slowly inching the tractor forward, pulling on the trailer against the chocks.
- After kingpin lock is completed, connect the tractor-to-trailer air system lines and the electrical cable to the trailer. Take care to prevent dirt or foreign material from entering the air system lines.

NOTICE

Always make sure the connection hanger keeps the trailer air hoses and electrical cables positioned so that they do not rub on anything. Rubbing may wear through hoses or cables, resulting in air leaks, or exposed or broken wires, potentially affecting trailer brake or electrical systems.

- Charge the air brake system with air, checking that the air connections do not leak.

WARNING

Incorrect fifth wheel lock adjustment could cause the trailer to disconnect, possibly resulting in serious personal injury or death.

- With the trailer tires chocked and the brakes set, check for clearance between the kingpin and the fifth wheel jaws by moving the tractor forward and backward against the locked kingpin. If slack is present, uncouple the trailer and have the fifth wheel inspected and adjusted by a certified technician.

Coupling, Jost Fifth Wheel

- Tilt the ramp down.
- Open the kingpin locks. See [Fig. 17.5](#).
- Back the vehicle close to the trailer, centering the kingpin on the fifth wheel.
- Chock the trailer tires.
- Connect the air lines and electrical cable.
- Ensure that the red trailer air supply valve (trailer brake) is pulled out, and that the trailer parking brakes are set. See [Chapter 5](#) in this manual for operation of the dash-mounted brake controls.

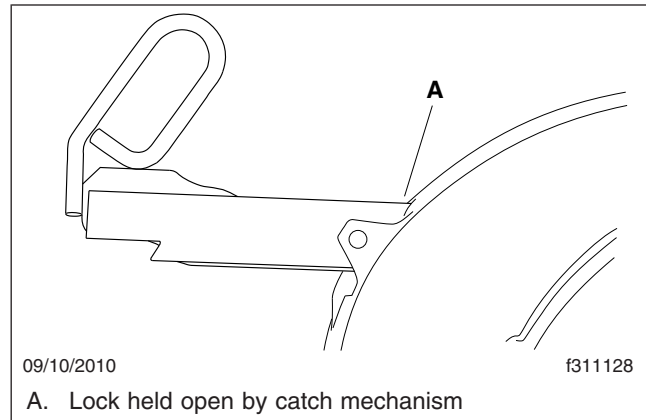

Fig. 17.5, Jost Release Handle Unlocked

NOTICE

Attempting to couple at the wrong height may cause improper coupling, which could result in damage to the fifth wheel or kingpin.

- Adjust the trailer height (if required).

For a standard fifth wheel plate, the trailer should contact the fifth wheel approximately 4 to 8 inches (10 to 20 cm) behind the pivot. See [Fig. 17.2](#).

For a low-lube fifth wheel plate, the fifth wheel must slide freely under the trailer, and the trailer should contact the fifth wheel at the pivot. See [Fig. 17.3](#).

- Back the tractor under the trailer.

On a standard fifth wheel, the fifth wheel must lift the trailer.

On a low-lube fifth wheel, do not lift the trailer as this may damage the fifth wheel plate.

- After sliding under the trailer, STOP to prevent from hitting the kingpin too hard, then resume backing slowly until the fifth wheel locks.

WARNING

A visual inspection is required by law. Some improper couplings can pass a pull test. Sound is not reliable. Get out of the cab and look. Incorrect coupling could cause the trailer to disconnect, possibly resulting in serious personal injury or death.

10. Apply the tractor parking brake, then perform a physical check for positive kingpin lock, and that there is no gap between the trailer and the fifth wheel. See [Fig. 17.4](#).
11. Ensure that the release handle is in the locked position adjacent to the casting. See [Fig. 17.6](#).

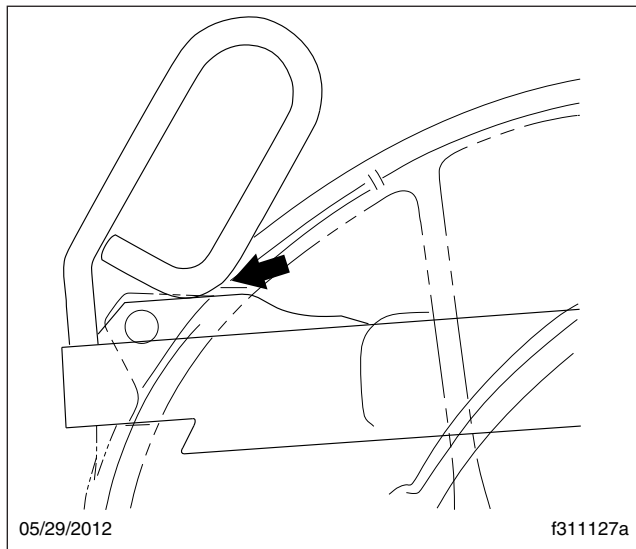

Fig. 17.6, Jost Release Handle Locked

12. Release the tractor parking brakes and test for kingpin lock by slowly moving the tractor forward, pulling on the trailer against the chocks.

Fifth Wheel Uncoupling

Manual Uncoupling

1. Apply the tractor and trailer parking brakes.
2. Chock the trailer tires.
3. Lower the trailer landing gear until the weight is removed from the fifth wheel.
4. Disconnect the tractor-to-trailer air system lines and electrical cable. Plug the air lines to prevent dirt or foreign material from entering the lines.
5. Verify that both the yellow parking-brake and red trailer-air-supply knobs are out, the tractor and trailer parking brakes are set, and that the trailer is prepared for uncoupling.
6. Release the kingpin locking mechanism following the instructions for each manufacturer below.

- 6.1 **Fontaine:** Lift the safety latch and pull the lock release handle to the unlocked position.
- 6.2 **Holland:** In the locked position the safety indicator swings freely over the release handle.

Pull the release handle out. When the upper release handle shoulder is outside the slot, raise the handle and place the shoulder of the upper rod against the plate casting, above the slot.

The fifth wheel is now in the lock position and is ready for uncoupling. As the tractor pulls away from the trailer the kingpin forces the jaw to rotate, contacting the lock. Continued rotation of the jaw forces the lock to move outward, and drops the upper rod back into the slot. The wheel is now ready for coupling.

- 6.3 **Jost:** Pull the retractable release handle out, then secure it in the open position with the catch. See [Fig. 17.5](#).
7. Release the tractor parking brake then drive out slowly, allowing the trailer to slide down the fifth wheel and pick-up ramps.

Air-Actuated Uncoupling

An air-actuated kingpin release valve is optional with any fifth wheel. See [Fig. 17.7](#).

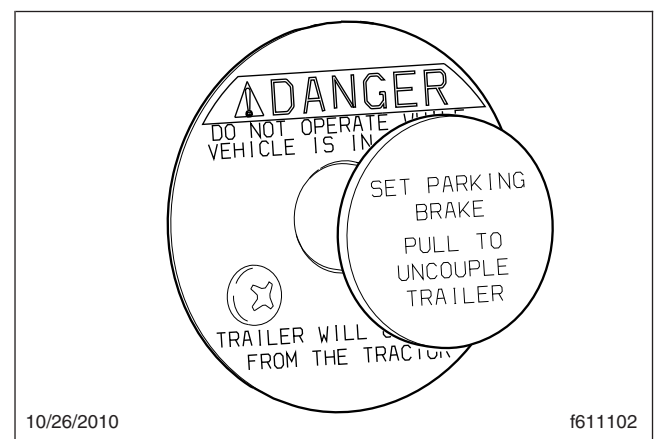

Fig. 17.7, Air-Actuated Kingpin Release Valve

Fifth Wheels

NOTE: In the event of an air system failure, air-actuated kingpins can be manually released following the instructions for manual unlocking.

WARNING

Once the kingpin release valve has been pulled the kingpin lock is released. The vehicle **MUST NOT** be driven with the trailer until the trailer has been uncoupled and coupled again. Failure to do so may result in separation of the trailer from the tractor, possibly causing serious personal injury or death.

Preparing the Trailer for Uncoupling

Before using the air valve to unlock a fifth wheel kingpin, prepare the trailer as follows.

1. Apply the tractor and trailer parking brakes.
2. Chock the trailer tires.
3. Lower the trailer landing gear until the weight is removed from the fifth wheel.
4. Disconnect the tractor-to-trailer air lines and electrical cable. Plug the air lines to prevent dirt or foreign material from entering the lines.

Air-Activated Kingpin Unlock, Fontaine or Holland Fifth Wheel

1. Verify that both the yellow parking-brake and red trailer-air supply knobs are out, the tractor and trailer parking brakes are set, and that the trailer is prepared for uncoupling.

NOTE: With a Fontaine or Holland fifth wheel, if the tractor parking brake is not set, the air-actuated kingpin-release valve will not activate.

2. Pull and hold the kingpin release valve (**Fig. 17.7**) until the kingpin lock mechanism opens and locks in place.
3. Release the kingpin release valve.
4. Release the tractor parking brake.
5. Drive out from under the trailer.

Air-Activated Kingpin Unlock, Jost Fifth Wheel

1. Verify that both the yellow parking-brake and red trailer-air-supply knobs are out, the tractor and

trailer parking brakes are set, and that the trailer is prepared for uncoupling.

NOTE: With a Jost fifth wheel, if the trailer parking brake is not set the air-actuated valve will not activate.

2. Release the tractor parking brake.
3. Pull and hold the kingpin release valve until the kingpin lock mechanism opens and locks in place.
4. After the trailer has slid down the fifth wheel and pick-up ramps, release the kingpin release valve.

Fifth Wheel Slide

WARNING

Adjust the fifth wheel slide correctly, and do not overload any tractor axle by incorrectly loading the trailer. Incorrect slide adjustment or improper axle loading could cause erratic steering and loss of vehicle control, possibly resulting in serious personal injury or death.

On sliding fifth wheel assemblies, the fifth-wheel plate is attached to rails that allow forward and rearward movement of the fifth wheel to optimally distribute the load across the axles. Slots are evenly spaced along the slide rails, and retractable wedges are positioned through the slots to hold the fifth wheel in the desired position.

The amount of load distribution on the front steering axle and rear drive axle(s) will have a direct effect on the steering control of the vehicle. Determine the front and rear axle weights by weighing the vehicle on scales designed for this purpose.

The maximum axle weight ratings are shown on the Federal Motor Vehicle Safety Standard (FMVSS) label or Canadian Motor Vehicle Safety Standard (CMVSS) label attached to the left rear door post of the tractor. The desired load on the axle is no less than 80 percent of the maximum axle weight rating, but in no instances should the axle load exceed the maximum axle weight rating given on the FMVSS or CMVSS label.

Air Slide Operation

The slide feature may be operated with an air switch mounted in the dash, that operates an air cylinder that locks and unlocks the slide. See [Fig. 17.8](#).

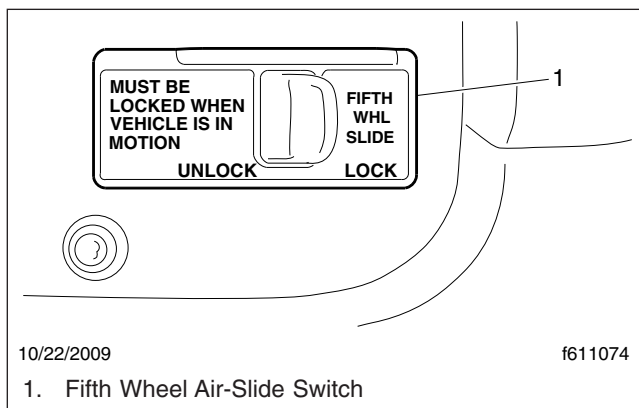

Fig. 17.8, Air-Slide Switch

1. Set the air-slide switch ([Fig. 17.8](#)) to UNLOCK. Ensure the locking plungers have released. See [Fig. 17.9](#).
For a Jost fifth wheel, the mechanism activates as shown in [Fig. 17.10](#).

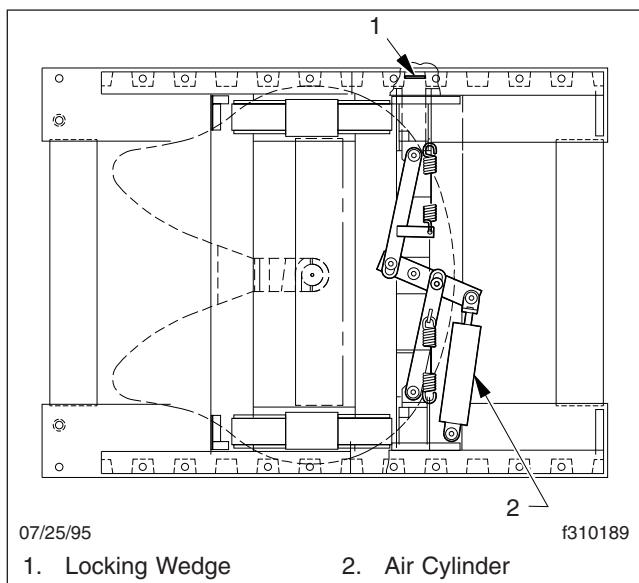

Fig. 17.9, Air-Operated Sliding Fifth Wheel (Fontaine shown)

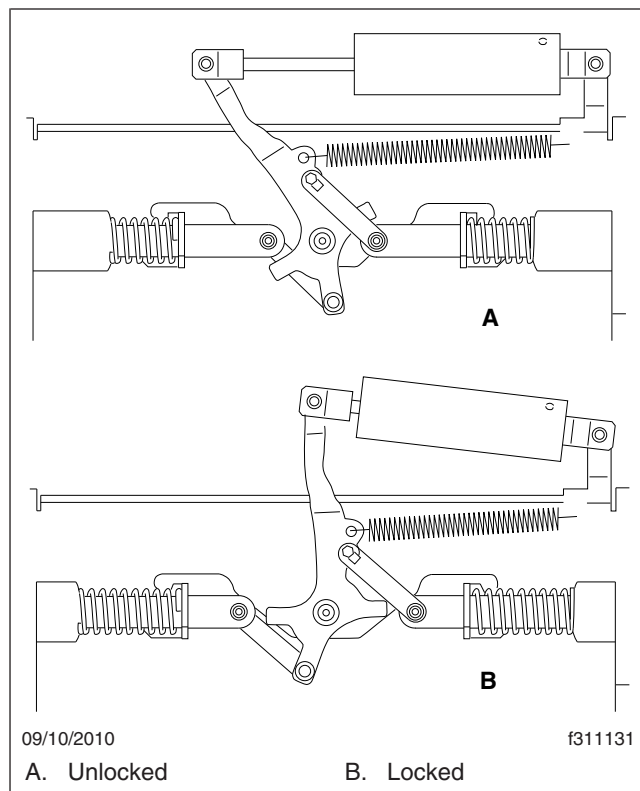

Fig. 17.10, Sliding Fifth Wheel, Jost

2. Lower the trailer landing gear just enough to remove the weight from the tractor.
3. Pull the red trailer-air-supply knob to set the trailer-parking brakes.
4. Slowly move the tractor forward or backward until the fifth wheel is in the desired location.

NOTICE

Ensure the trailer landing gear does not come in contact with the tractor frame or other components, and that the front of the trailer will not come in contact with the rear of the cab or other components if they extend beyond the rear of the cab.

5. Apply the tractor parking brakes.



Check that the locking wedges have seated in the slots. Failure to achieve complete lockup may

Fifth Wheels

allow disengagement of the tractor from the trailer, possibly resulting in serious personal injury or death.

6. Set the air-slide switch to LOCK. Visually inspect the locking wedges or plungers to make sure that they are fully inserted in the slide rail slots. Verify that the plungers have engaged by tugging the tractor forward while the trailer brakes are locked and the tires are chocked.

NOTE: The fifth wheel may need to be moved slightly to enable the locking wedges to fully lock.

18

Trailer Couplings

Air-Suspension Dump Valve	18.1
Holland Trailer Couplings	18.1
Premier Trailer Couplings	18.2

Trailer Couplings

Air-Suspension Dump Valve

NOTICE

Never exhaust air from the suspension while driving. When the air is exhausted, the suspension will not absorb road shocks, and components may be damaged.

The air-suspension dump valve may be used to aid in connecting or disconnecting from a trailer. When the valve switch is set to LOWER, the air-suspension dump valve deflates the air springs to lower the rear of the vehicle. See Fig. 18.1. In the AUTO position, the automatic ride-control valves operate for normal driving.

NOTICE

Do not operate the vehicle over uneven ground such as ramps, speed bumps, curbs, etc. with the air springs deflated. Doing this may lead to air bag separation from the piston, preventing the suspension air springs from reinflating.

Holland Trailer Couplings

General Information

IMPORTANT: Refer to the Holland web site (www.hollandhitch.com) for additional information.

The Holland trailer coupling (Fig. 18.2) is designed for use with trailers having a maximum gross weight of 49,000 lbs (22 226 kg). It is a swivel-mount pintle hook designed for heavy-duty construction, utility, and off-road applications. It is fastened to the rear closing crossmember of the vehicle and is a non-air-adjusted coupling.

Trailer Hookup

1. Chock the trailer tires.
2. Remove the cotter pin, then lift the lock and raise the latch.
3. Back the vehicle up until the drawbar eye is over the horn of the pintle hook.
4. Lower the trailer until the drawbar eye rests on the pintle hook.

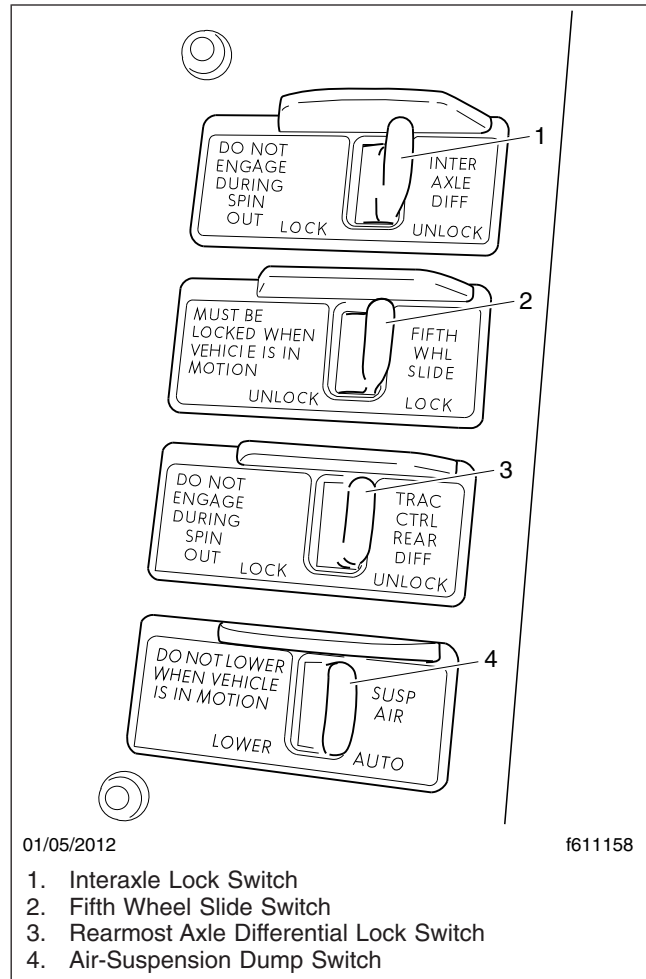

Fig. 18.1, Axle and Suspension Switches

5. Close the latch, then insert the cotter pin.

NOTICE

Always make sure the connection hanger keeps the trailer air hoses and electrical cables positioned so that they do not rub on anything. Rubbing may wear through hoses or cables, resulting in air leaks, or exposed or broken wires, potentially affecting trailer brake or electrical systems.

6. Connect the trailer electrical and air lines.

Trailer Release

1. Apply the truck and trailer parking brakes.

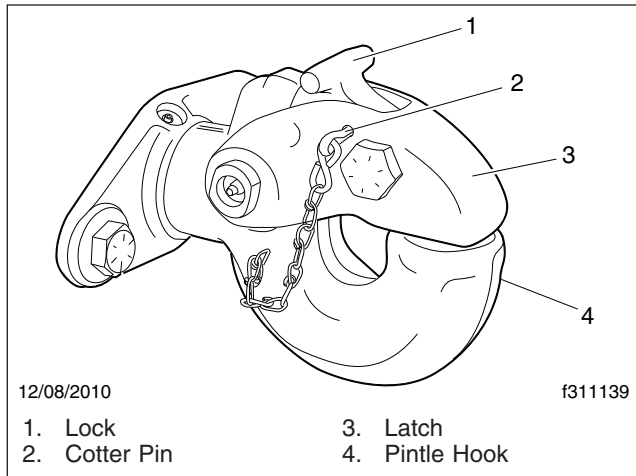

Fig. 18.2, Holland Trailer Coupling

⚠ WARNING

Do not use the trailer air supply for parking trailers not equipped with spring parking brakes. This applies the trailer service brakes only. As air bleeds from the trailer brake system, brake application is lost. This could allow the unattended vehicle to roll away, possibly resulting in serious personal injury or death.

2. Chock the front and rear tires of the trailer.
3. Disconnect the trailer air and electrical lines. Plug the air lines to keep them free of dirt.
4. Take the weight of the trailer drawbar off the pintle hook.
5. Open the latch by first removing the cotter pin, then lift up the lock and raise the latch.
6. Slowly drive the vehicle away from the trailer.

Premier Trailer Couplings

General Information

IMPORTANT: Before operating the Premier coupling, refer to the Premier web site at www.premier-mfg.com for complete safety, operation, and maintenance instructions.

Trailer couplings are attached to the rear closing crossmember. The Premier trailer couplings (**Fig. 18.3**) are designed for use with trailers having a maximum gross weight of 100,000 lbs (45 455 kg).

The Premier 2200 and 2400 trailer couplings are air adjusted couplings with a rigid pintle hook, attached to the rear closing crossmember. An air chamber, mounted forward of the coupling, operates a push rod, which pushes against a shoe inside the coupling. The shoe maintains constant pressure on the eye of the trailer drawbar when it's over the pintle hook. This takes up any slack in the trailer connection, providing smoother towing and less wear on the pintle hook. The air pressure is activated when the trailer brakes are released.

Trailer Hookup

1. Chock the trailer tires.
2. Push the latch lock towards the mounting plate as far as possible then, while holding the latch lock in place against the mounting plate, pull the top of the latch as far as possible toward the pintle hook.
3. While holding the latch in place, release the latch lock.
4. Back the vehicle up until the drawbar eye is over the pintle hook, then lower the trailer.
5. Pull the top of the latch as far as possible toward the pintle hook then, while holding the latch in position, push the latch lock towards the mounting plate.
6. While holding the latch lock in place against the mounting plate, release the latch.
7. Release the latch lock and make sure it is fully seated in the slot on top of the latch.

NOTICE

Always make sure the connection hanger keeps the trailer air hoses and electrical cables positioned so that they do not rub on anything. Rubbing may wear through hoses or cables, resulting in air leaks, or exposed or broken wires, potentially affecting trailer brake or electrical systems.

8. Connect the trailer's electrical and air lines.

Trailer Release

1. Apply the truck and trailer parking brakes.

Trailer Couplings

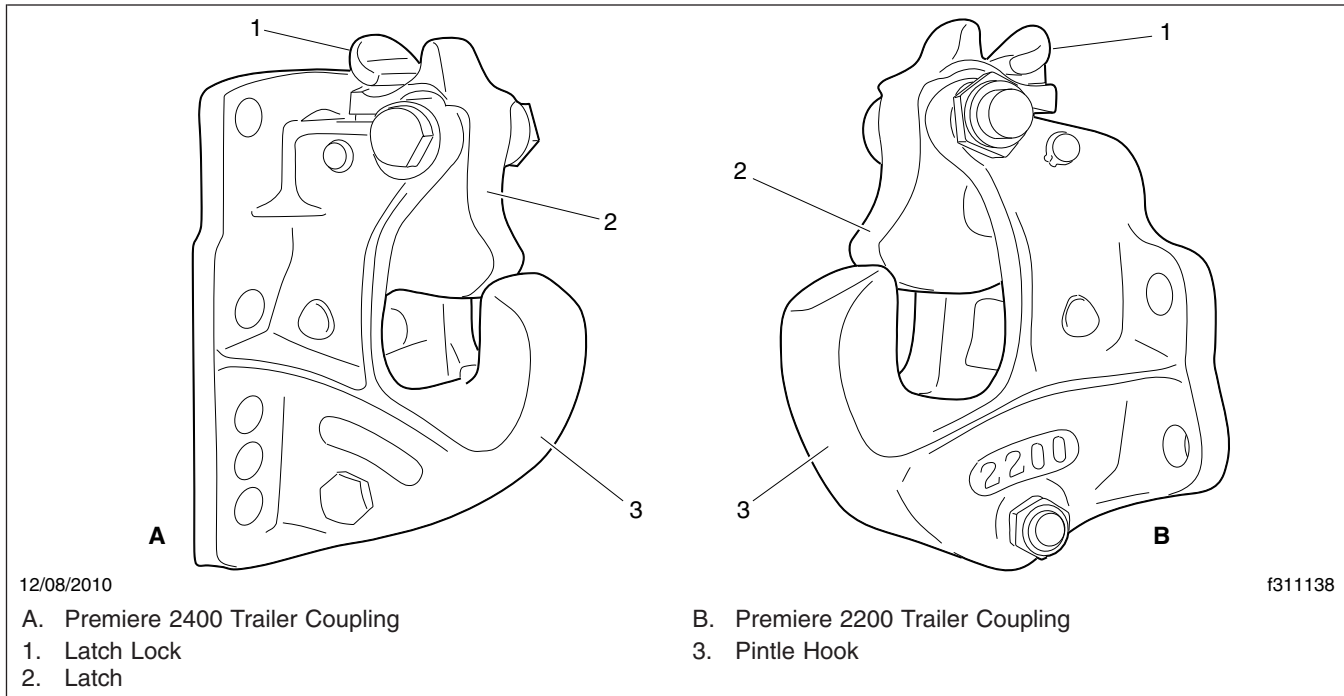

Fig. 18.3, Premiere 2200 and 2400 Trailer Couplings

WARNING

Do not use the trailer air supply for parking trailers not equipped with spring parking brakes. This applies the trailer service brakes only. As air bleeds from the trailer brake system, brake application is lost. This could allow the unattended vehicle to roll away, possibly resulting in serious personal injury or death.

2. Chock the front and rear tires of the trailer.
3. Disconnect the trailer air and electrical lines. Plug the air lines to keep them free of dirt.
4. Take the weight of the trailer drawbar eye off the pintle hook.
5. Push the latch lock towards the mounting plate as far as possible then, while holding the latch lock in this position, pull the top of the latch as far as possible toward the pintle hook.
6. While holding the latch in place, release the latch lock.
7. Slowly drive the vehicle away from the trailer.

19

Headlight Aiming

Preliminary Checks	19.1
Checking Headlight Aim	19.1
Adjusting Headlight Aim	19.1

Headlight Aiming

Preliminary Checks

Before checking or adjusting the headlight aim, complete the following inspection:

- Remove any large amounts of mud or ice from the underside of the fenders.
- Check the springs for sagging or broken leaves.
- Check the suspension for proper functioning of the leveling mechanism. If the vehicle is equipped with an air suspension, make sure that the height is properly adjusted.
- With the vehicle unloaded, check that the tires are inflated to the recommended air pressure.
- Clean the headlight lenses. Use a soft cloth with mild, non-caustic soap or detergent, and water.

Checking Headlight Aim

1. Park the vehicle on a level surface, 25 ft (7.6 m) away from, and perpendicular to, a vertical screen or wall. Shut down the engine and set the parking brake. Chock the tires.
2. Each headlight has a height adjusting dot. See [Fig. 19.1](#). Measure the distance from the ground to the height adjusting dot on each headlight ([Fig. 19.2](#), Item A). Note those distances.

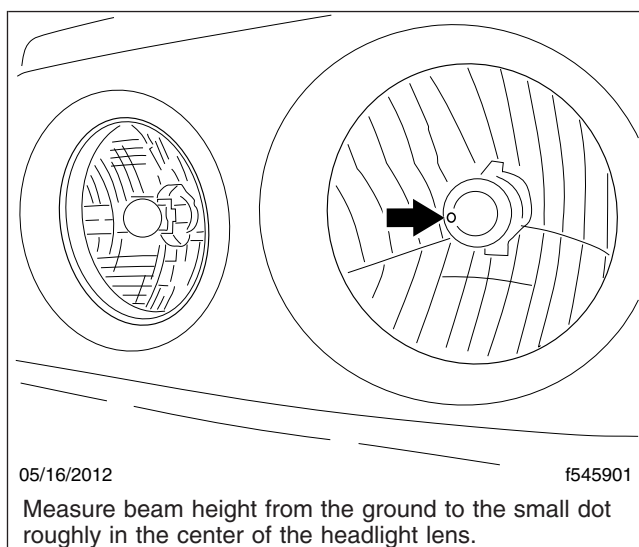

Fig. 19.1, Headlight Beam Height Adjusting Dot

3. On the screen or wall, mark the locations of each headlight bulb center using the distances found in step 2. See [Fig. 19.2](#), Items 2 and 3.
4. Turn on the low-beam headlights.
5. Check the vertical adjustment of the low beams. The center of each beam projection should fall on or near the marks made during step 3. See [Fig. 19.3](#).
6. Use [Table 19.1](#) to determine the maximum vertical distance allowable between the marks on the wall and the center of each low-beam projection. If the distance between either projection center and the mark made on the wall or screen is greater than the maximum distance given in [Table 19.1](#), adjust the vertical positioning of that headlight.

Adjusting Headlight Aim

NOTE: Freightliner vehicles are offered with various headlight assembly options. Because of the various options, the location of adjustment screws on your vehicle's headlight assembly may vary from what is shown here.

The adjusting screw is located on the upper outboard corner of the headlight assembly. See [Fig. 19.4](#). Turn the adjusting screw clockwise to raise the beam and counterclockwise to lower it, until the beam pattern meets the acceptable standard.

Headlight Aiming

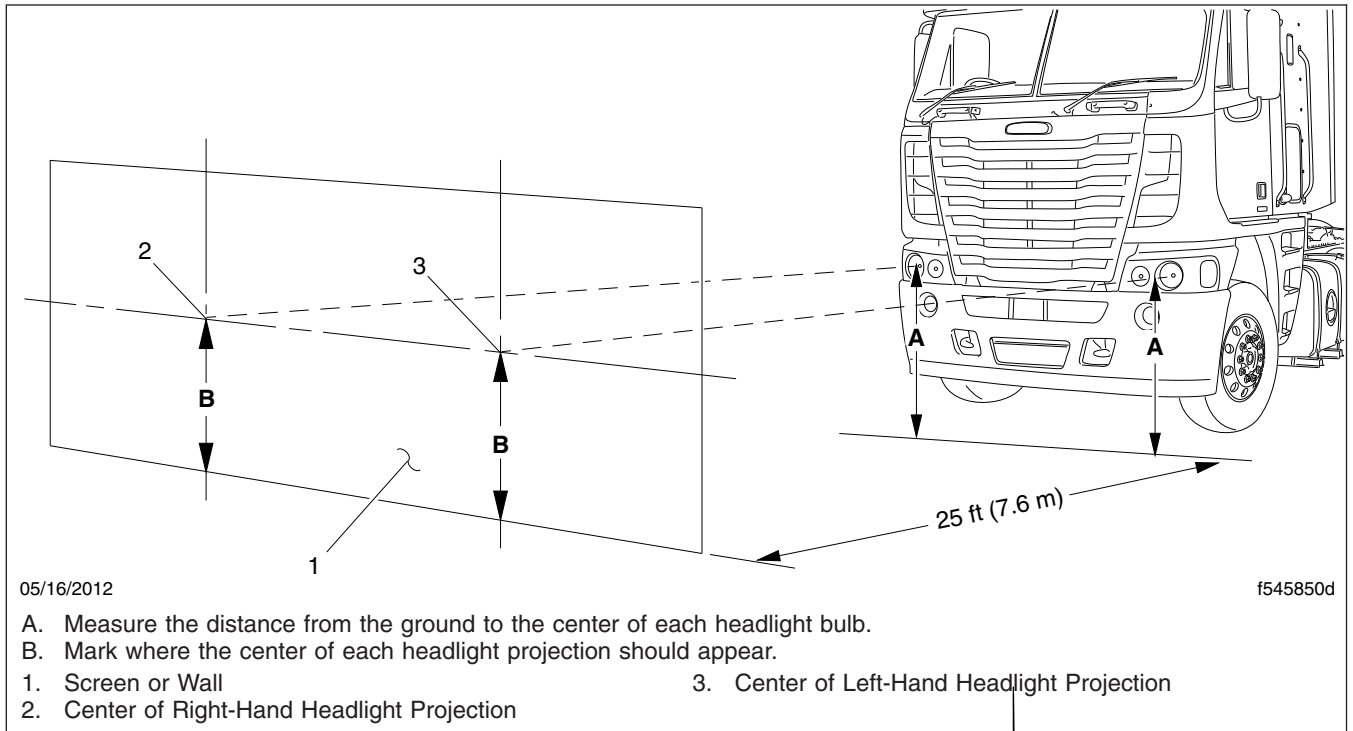

Fig. 19.2, Headlight Aiming Screen/Wall

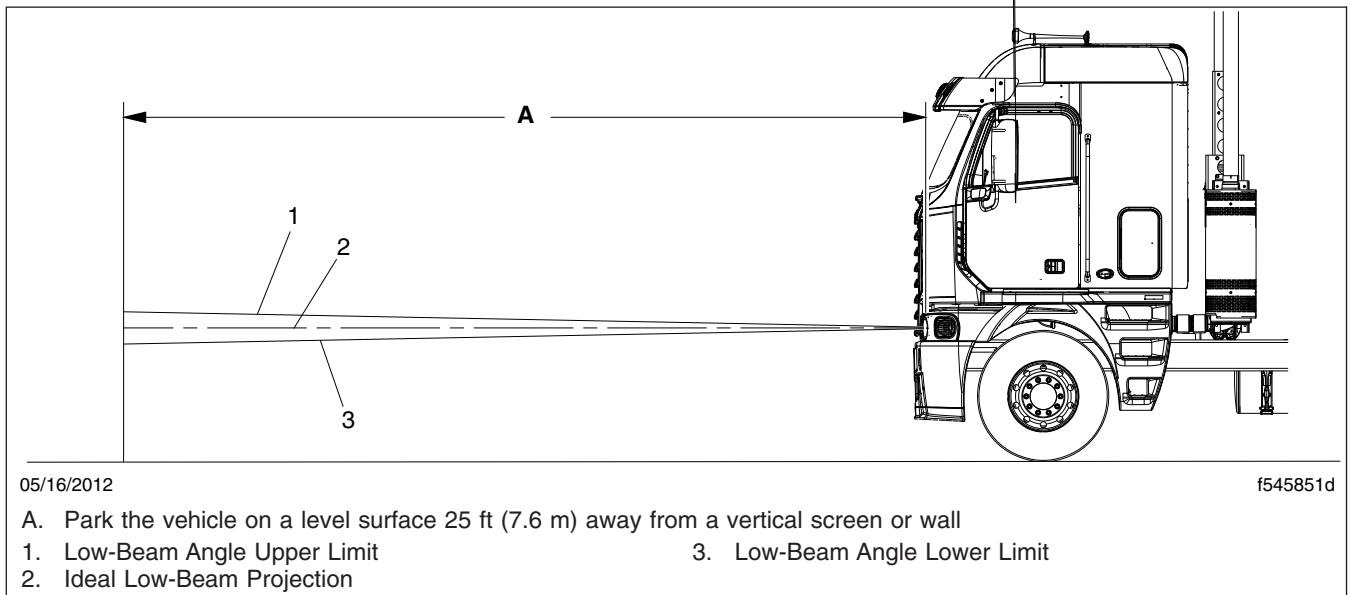

Fig. 19.3, Vertical Low-Beam Headlight Variation Limits

Headlight Aiming

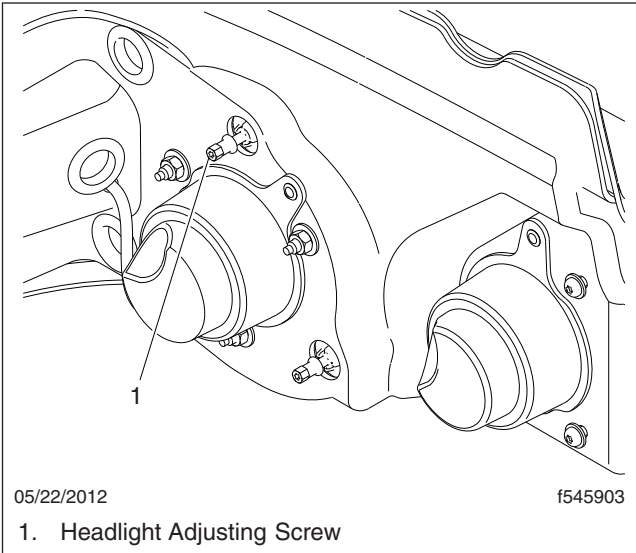

Fig. 19.4, Headlight Adjusting

Vertical Low-Beam Headlight Variation Limits			
Distance Between Ground and Headlight: in (mm)	Desired Variation (Fig. 19.3, Item 2): in (mm)	Upper Limit (Fig. 19.3, Item 1): in (mm) up	Lower Limit (Fig. 19.3, Item 3): in (mm) down
22–36 (560–900)	0	3.9 (100)	3.9 (100)
36–48 (900–1200)	2 (50) down	2 (50)	6 (150)
48–54 (1200–1400)	2.5 (64) down	1.6 (40)	6.5 (165)

Table 19.1, Vertical Low-Beam Headlight Variation Limits

20

Cab Appearance

Care of Fiberglass Parts	20.1
Care of Chrome Parts	20.1
Dashboard Care	20.1
Vinyl Upholstery Cleaning	20.1
Velour Upholstery Cleaning	20.2
Care of Exterior Lights	20.2

Cab Appearance

Care of Fiberglass Parts

Wash unpainted fiberglass air fairings and shields monthly with a mild detergent, such as dishwashing liquid. Avoid strong alkaline cleansers.

Apply a wax specifically designed for fiberglass.

Care of Chrome Parts

To prevent rust, keep chrome parts clean and protected at all times. This is especially important during winter driving and in coastal areas where there is exposure to salt air.

When cleaning chrome parts, use clean water and a soft cloth or sponge. A mild detergent may also be used.

Sponge gently, then rinse. If necessary, use a non-abrasive chrome cleaner to remove stubborn rust or other material. Do not use steel wool.

To help protect the chrome after cleaning, apply a coat of polishing wax to the surface. Never use wax on parts that are exposed to high heat, such as exhaust pipes.

Dashboard Care

NOTICE

When cleaning the dashboard, instrument panel, or gauge lens covers, do not use Armor-All Protectant®, STP Son-of-a-Gun®, window cleaner, or other equivalent treatments. These cleaners contain vinyl plasticizers which can cause stress crazing in the interior plastic panels and can result in cracking of the panels. Some cleaners can also have an adverse effect on the clear plastic of instrument panels and gauge lens covers, resulting in a foggy or cloudy appearance. This type of damage is not covered by vehicle warranty.

To clean the dashboard, instrument panel, and gauge lens covers, use a cloth dampened with warm soapy water. Make certain to wring the cloth out well before cleaning, as excess water will damage the electrical components.

Vinyl Upholstery Cleaning

To prevent soiling, frequent vacuuming or light brushing to remove dust and dirt is recommended. Harsh cleaning agents can cause permanent damage to vinyl upholstery. To preserve the upholstery and prevent damage, carefully review the following sections for recommended cleaning procedures. Waxing or refinishing improves soil resistance and cleanability for all vinyls. Any hard wax, such as that used on automobiles, may be used.

Ordinary Dirt

Wash the upholstery with warm water and mild soap, such as saddle or oil soap. Apply soapy water to a large area and allow to soak for a few minutes, then rub briskly with a cloth to remove the dirt. This can be repeated several times, as necessary.

If dirt is deeply imbedded, use a soft bristle brush after applying the soap.

If dirt is extremely difficult to remove, wall-washing preparations normally found around the home can be used. Powdered cleaners, such as those used for sinks and tiles, are abrasive and must be used with caution as they can scratch the vinyl or give it a permanent dull appearance.

Chewing Gum

Harden the gum with an ice cube wrapped in a plastic bag, then scrape it off with a dull knife. Any remaining traces of gum can be removed with an all-purpose light oil (peanut butter will also work) and wiped off.

Tars, Asphalts, and Creosote

Each of these items stains vinyl after prolonged contact. They should be wiped off immediately and the area carefully cleaned, using a cloth dampened with naphtha.

Paint, Shoe Heel Marks

Paint should be removed immediately. Do not use paint remover or liquid-type brush cleaner on vinyl. An unprinted cloth, dampened with naphtha or turpentine may be used. Use care to prevent contact with parts of the upholstery that are not vinyl.

Sulfide Stains

Sulfide compounds, such as those found in eggs and some canned goods, can stain after prolonged contact with vinyl. These stains can be removed by placing a clean, unprinted piece of cloth over the spotted area and pouring a liberal amount of 6 percent hydrogen peroxide onto the cloth. Allow the saturated cloth to remain on the spot for 30 to 60 minutes. For stubborn spots, allow the hydrogen-peroxide saturated cloth to remain on the area overnight. Use caution to prevent the solution from seeping into the seams, or it will weaken the cotton thread.

Nail Polish and Nail Polish Remover

Prolonged contact with these substances causes permanent damage to vinyl. Careful blotting immediately after contact minimizes damage. Do not spread the liquid during removal.

Shoe Polish

Most shoe polishes contain dyes which penetrate vinyl and stain it permanently. Shoe polish should be wiped off as quickly as possible using naphtha or lighter fluid. If staining occurs, try the procedure used for sulfide stains.

Ball Point Ink

Ball point ink can sometimes be removed if rubbed immediately with a damp cloth, using water or rubbing alcohol. If this does not work, try the procedure used for sulfide stains.

Miscellaneous

If stains do not respond to any of the treatments described above, it is sometimes helpful to expose the vinyl to direct sunlight for up to 30 hours. Mustard, ball point ink, certain shoe polishes, and dyes often bleach out in direct sunlight, leaving the vinyl undamaged.

Velour Upholstery Cleaning

To prevent soiling, frequent vacuuming or light brushing to remove dust and dirt is recommended. Spot clean with a mild solvent or an upholstery shampoo, or the foam from a mild detergent. When using a solvent or a dry-cleaning product, follow the instructions carefully, and clean only in a well-ventilated area.

Avoid any product that contains carbon tetrachloride or other toxic materials. With either method, pretest a small area before proceeding. Use a professional upholstery cleaning service when extensive cleaning is needed.

Grease and Oil-Based Stains

Dampen a small absorbent cloth with dry-cleaning solvent or spot remover. Apply the cloth carefully to the spot from the outer edge to the center. Pat and blot the spot with a clean, dry cloth. Repeat several times, as necessary, turning the cloths so that the stain does not redeposit on the fabric.

Sugar and Water-Based Stains

Apply water-based detergent or cleaner, working in circular motions. Pat and blot as dry as possible. Repeat, if necessary, before drying thoroughly.

Chewing Gum or Wax

Harden the gum or wax with an ice cube wrapped in a plastic bag, then scrape it off with a dull knife. Excess wax can be absorbed by placing a thick white blotter over the wax and heating with a warm (not hot) iron. Remove the remainder by using the procedure for grease and oil-based stains.

Mildew

Brush the dry fabric with a soft brush. Sponge with detergent, and blot. If the fabric is colorfast, dilute a teaspoon of bleach in one quart (one liter) of cool water. Apply with a swab, directly on the mildew stain. Dab repeatedly with clear, cool water, and blot dry.

Care of Exterior Lights

Clean the headlight lenses by hand only, using a flannel cloth with mild, non-caustic soap or detergent, and water.

NOTICE

Do not use a power buffer, paper towels, chemical solvents, or abrasive cleaners on the headlight lens. These materials can remove the UV coating from the surface, resulting in yellowing of the lens.

21

In an Emergency

Hazard Warning Lights	21.1
Fire Extinguisher	21.1
Emergency Kit, Optional	21.1
Emergency Filter Replacement, DAVCO	21.1
Emergency Starting With Jumper Cables	21.2
Towing	21.3
Fire in the Cab	21.6

In an Emergency

Hazard Warning Lights

The hazard warning light switch tab is located on the turn signal control lever. See [Fig. 21.1](#). To operate the hazard lights, pull the tab out. All of the turn signal lights and both of the indicator lights on the control panel will flash.

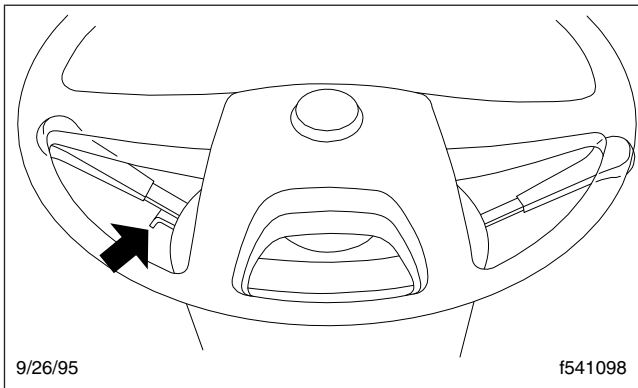

Fig. 21.1, Hazard Warning Light Switch Tab

To cancel the hazard warning lights, push the turn signal control lever either up or down, then return the lever to its neutral position.

Fire Extinguisher

A fire extinguisher is located either in the cab by the driver's door, or in the baggage compartment.

Emergency Kit, Optional

An optional emergency kit may be located in the cab. The package includes one or more of each of the following: first aid kit, a reflective vest, and a triangular reflector and flare kit.

If there is an emergency while driving, cautiously pull off the road, paying attention to other traffic. Turn on the hazard warning lights. Place the flares and reflector along the side of the road, to alert other drivers that an emergency situation exists.

WARNING

Use extreme care when placing flares in emergency situations that involve exposure to flammable substances such as fuel. An explosion or fire could occur causing serious personal injury.

Emergency Filter Replacement, DAVCO

If the filter cover on the DAVCO fuel/water separator is broken, it will not be possible to operate the vehicle. A standard spin-on filter will correct this problem.

Refer to the DAVCO web site for additional information, www.davcotec.com.

WARNING

Fluid circulated through the fuel/water separator to heat the fuel may be diesel fuel returned from the engine, or engine coolant. Drain the fuel/water separator only when the engine and fluids have cooled. Draining it when the engine is hot could cause severe personal injury due to scalding.

If returning fuel is released into the atmosphere, its vapors can ignite in the presence of any ignition source. Do not expose the fuel to, or work with the fuel system near, open flame or intense heat. To do so could cause fire, possibly resulting in serious personal injury or property damage.

1. Shut down the engine, apply the parking brake, and chock the tires.
2. Put a clean receptacle under the fuel/water separator and attach a piece of hose to the drain valve, to direct fuel into the receptacle.

NOTE: The drain valve on the Fuel Pro 382 has a 1/2-inch (12.7-mm) opening; use a hose with a 1/2-inch pipe thread to fit correctly.

3. Remove the vent cap ([Fig. 21.2](#), Item 14) and open the drain valve ([Fig. 21.2](#), Item 1) to drain the fuel to just below the collar level, then close the drain valve.
4. Using a DAVCO collar wrench ([Fig. 21.3](#)), remove the clear cover and collar.

NOTE: Broken vent cap and collar warranty claims will not be accepted if any tool other than a DAVCO collar wrench, p/n 380134 or 382002, is used for removal. During installation, the vent cap and collar are to be **hand-tightened only**, not tightened with a wrench.

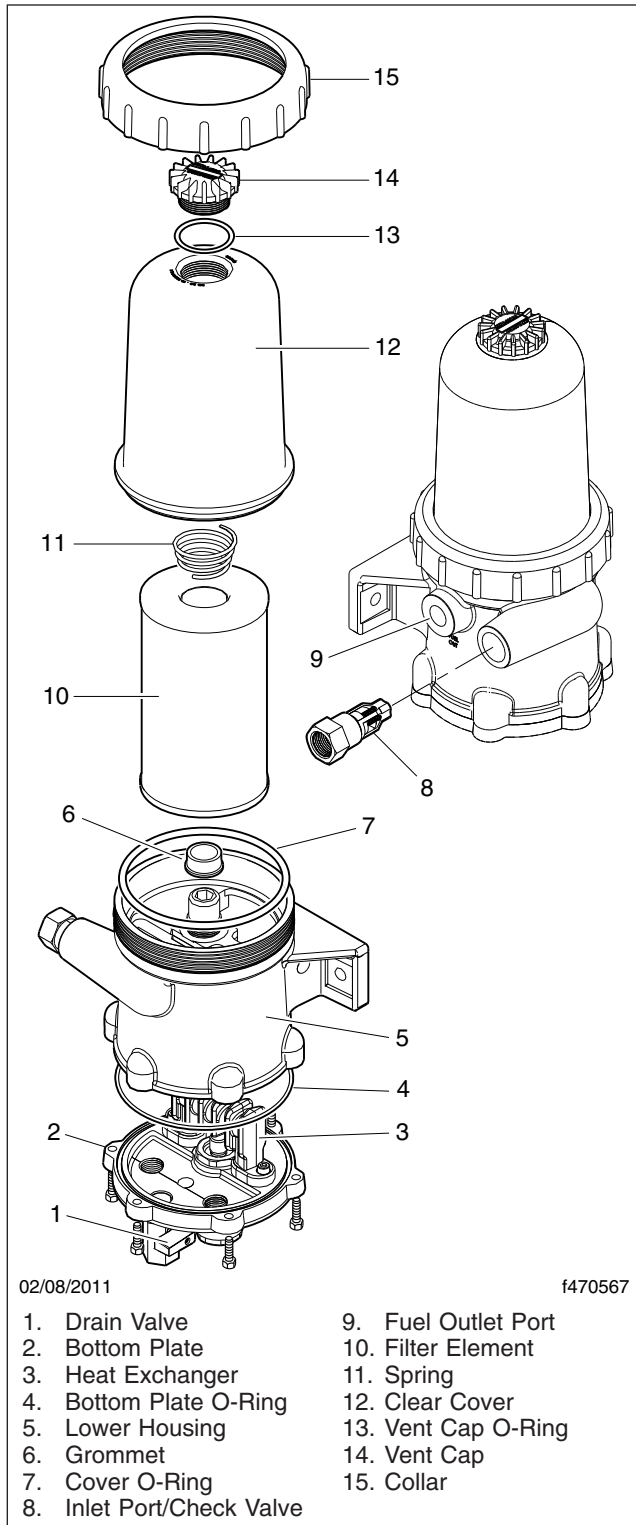

Fig. 21.2, DAVCO Fuel/Water Separator (Fuel Pro 382 shown)

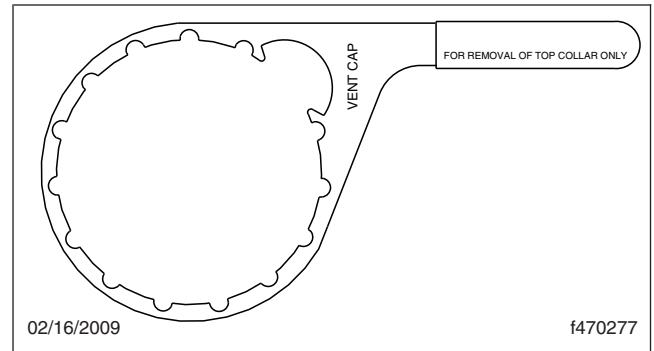

Fig. 21.3, DAVCO Collar Wrench

5. Remove the filter and dispose of it in an environmentally acceptable manner.
6. Clean all threads and sealing surfaces very thoroughly. Even a small amount of dirt will prevent the fuel/water separator from sealing, and an air leak will result.
7. Ensure that the drain valve is closed.
8. Remove the filter grommet from the filter stud, if equipped.
9. Fill the housing to the top with clean diesel fuel.
10. Install a standard fuel filter element on the filter stud. If a standard fuel element is not available, install a spin-on fuel filter element (part number FF105 or equivalent).
11. Install the cover O-ring, clear cover, and the collar. Hand-tighten the collar.
12. Install and hand-tighten the vent cap O-ring and vent cap.
13. Start the engine. When the lubricating oil reaches its normal operating pressure, increase engine speed to high idle for one to two minutes to purge air from the system.

Emergency Starting With Jumper Cables

When using jumper cables, follow the instructions below.



Batteries release explosive gas. Do not smoke when working around batteries. Put out all flames

In an Emergency

and remove all sources of sparks or intense heat in the vicinity of the battery. Do not allow the vehicles to touch each other. Do not lean over the batteries when making connections, and keep all other persons away from the batteries. Failure to follow these precautions could lead to severe personal injury as a result of an explosion or acid burns.

NOTICE

Make sure both electrical systems are the same voltage. Electronic devices on both vehicles can be damaged when connected to a vehicle with a different operating voltage.

1. Apply the parking brakes and turn off all lights and other electrical devices. Ensure that the vehicles are not touching and both ignition switches are turned to the OFF position.

IMPORTANT: Do not attempt to jump start a damaged battery.

2. Remove the battery box cover.

NOTICE

Always connect the batteries and jumper cables correctly (positive-to-positive and negative-to-negative). Connecting a charging device backwards (positive-to-negative) can severely damage the vehicle electrical content and cause non-warrantable failures.

IMPORTANT: On vehicles equipped with optional jump start posts, connect to these posts instead of the battery terminals. Jump start posts may be installed in various locations on the vehicle.

3. Connect the positive (+) jumper cable to the positive battery terminal or jump start post. See [Fig. 21.4](#).
4. Connect the other end of the positive jumper cable to the positive terminal or jump start post on the booster battery providing the charge.



Do the next step exactly as instructed and do not allow the clamps of one cable to touch the

clamps of the other cable. Otherwise, a spark could occur near a battery, possibly resulting in severe personal injury from explosion or acid burns.

5. Connect the negative (-) jumper cable to the negative terminal or jump start post on the booster battery.
6. Connect the other end of the negative jumper cable to the negative ground stud on the vehicle requiring the jump start.
7. Start the engine of the vehicle providing the jump start and let the engine run a few minutes to charge the batteries of the other vehicle.
8. Attempt to start the engine of the vehicle receiving the jump. Do not operate the starter longer than 30 seconds, and wait at least two minutes between starting attempts to allow the starter to cool.
9. When the engine starts, let it idle a few minutes.
10. Disconnect the negative jumper cable from the negative cable stud on the jump started vehicle.
11. Disconnect the negative jumper cable from the booster battery.
12. Disconnect the positive cable from the booster battery.
13. Disconnect the other end of the positive jumper cable from the jump started vehicle.
14. Install the battery box cover; be sure it is positioned properly before fastening the latch.

Towing

When it is necessary to tow the vehicle, make sure the instructions below are closely followed to prevent damage to the vehicle.



Do not tow an unbraked vehicle if the combined weight of both vehicles is more than the sum of the gross axle weight ratings (GAWR) of the towing vehicle. Otherwise brake capacity will be inadequate, which could result in personal injury or death.

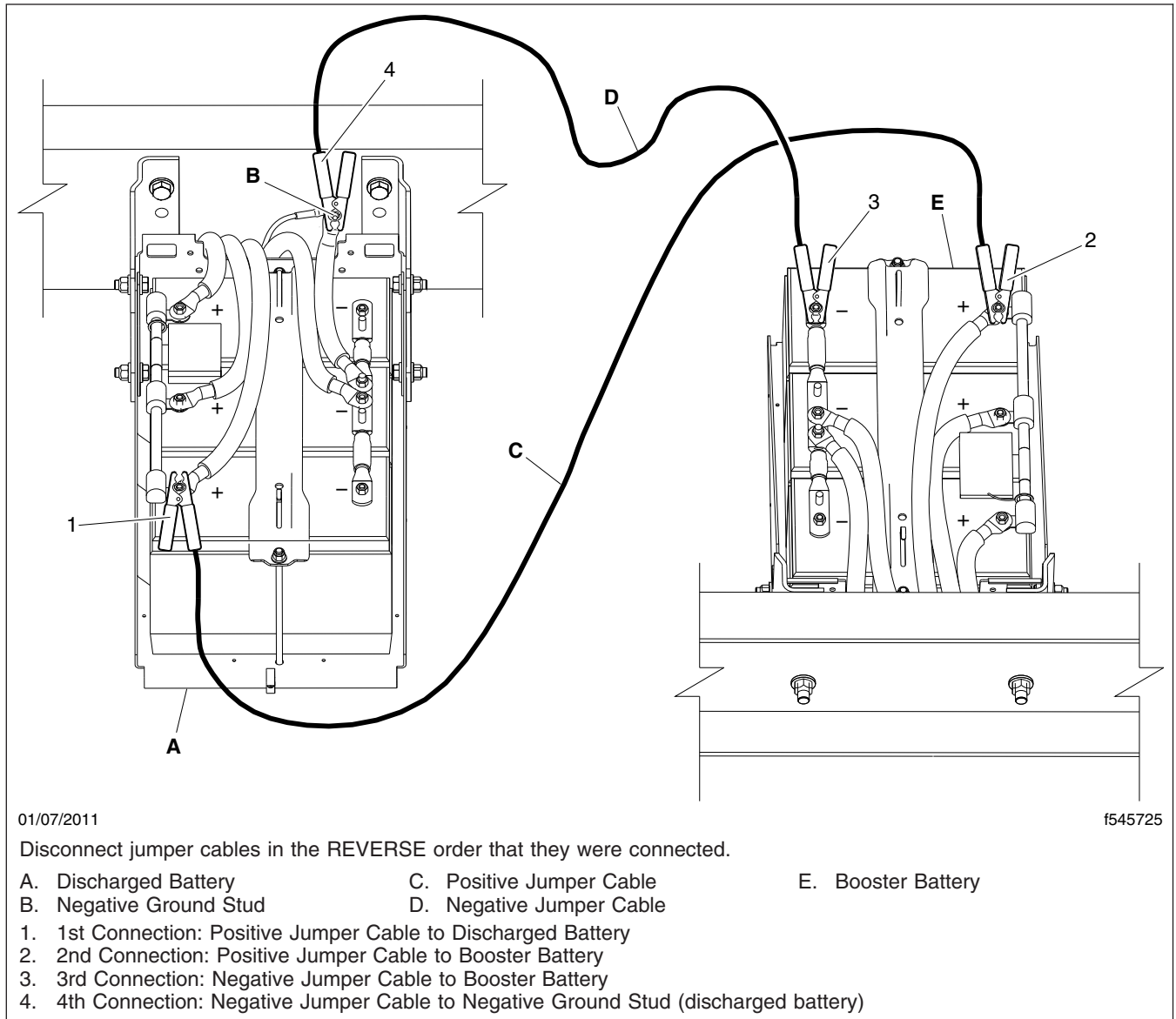

Fig. 21.4, Jumper Connections

Front Towing Hookup

1. Disconnect the battery ground cables.

NOTICE

Failure to remove the axle shafts when towing the vehicle with the rear wheels on the ground could result in damage to the transmission and other components.

2. Remove both drive axle shafts. On dual drive axles, if the vehicle is to be lifted and towed, remove only the rearmost drive axle shafts.
 On vehicles equipped with an air fairing, remove both the forward and rearmost drive axle shafts if there is insufficient towing clearance.
3. Cover the ends of the hubs with metal plates or plywood cut to fit the axle opening, and drilled to fit the axle shaft studs. This prevents lubricant

In an Emergency

from leaking out, and will keep contaminants from getting into and damaging the wheel bearings and axle lubricant.

NOTICE

Failure to protect the frame rails from the chains could cause damage, leading to eventual frame failure.

4. On dual drive axles, if the vehicle is to be lifted and towed, chain the forward rear-axle assembly to the vehicle frame; use protection to keep the chains from damaging the frame.
5. Remove the bumper extension and chrome bumper, if so equipped. Remove the bumper fairing, if so equipped.
6. On vehicles equipped with an air fairing, adjust the trim tab to the lowest position.

NOTICE

Do not pass a sling (for example, a rope or chain) from one tow hook to another to fasten for towing. Known as reeving, this practice is not permissible in most industrial applications of towing and hoisting. Reeving can overload the hooks and result in damage to the vehicle.

7. Attach the towing device. Due to the many variables that exist in towing, positioning the lifting and towing device is the sole responsibility of the towing-vehicle operator.
8. On vehicles equipped with an air fairing, measure the distance from the ground to the bumper, or from the ground to a frame bracket.
9. Lift the vehicle, and secure the safety chains. If extra towing clearance is needed, remove the front wheels.

WARNING

Failure to lower the vehicle could result in the air fairing striking an overhead obstruction, such as a bridge or overpass, and causing vehicle damage or personal injury.

10. On vehicles equipped with an air fairing, repeat the measurement taken in step 8. The difference between the two measurements must not exceed

14 inches (36 cm). If necessary, lower the vehicle.

11. Connect the clearance lights, taillights, and signal lights. Connect any special towing lights required by local regulations.

WARNING

Failure to chock the tires or connect the tow truck's air brake system before releasing the spring parking brakes could allow the disabled vehicle to suddenly roll. This could cause property damage or personal injury.

12. Chock the disabled vehicle's tires, and connect the towing vehicle's air brake system to the vehicle being towed. Then, release the spring parking brakes and remove the chocks.

Rear Towing Hookup

NOTICE

Using a rear towing hookup on a vehicle equipped with a roof fairing could cause damage to the cab structure.

If reverse towing at speeds above 45 mph (70 kph) is necessary, hold down the cab with tension straps looped over the cab shocks and under the frame rails. Failure to do so could allow the wind load to lift the cab unexpectedly, resulting in damage to the air springs and other components.

1. If the vehicle is equipped with cab air suspension, and reverse towing at speeds above 45 mph (70 kph) is necessary, hold down the cab as follows:
 - 1.1 Drain the air from the cab air springs.
 - 1.2 Loop a 2-inch (5-cm) ratchet-style tension strap (rated 2000 lb [900 kg] minimum work load) over the top of the cab shock and under the frame rail. Tighten the strap for a snug fit. If the cab is equipped with two or more shocks, restrain the aftmost shock on each side of the vehicle.
2. Place the front tires straight forward and secure the steering wheel in this position.
3. Disconnect the battery ground cables.

NOTICE

Failure to protect the frame rails from the chains could cause damage, leading to eventual frame failure.

4. On dual drive axles, using protection to keep the chains from damaging the vehicle frame, chain the forward-rear drive axle to the frame.
5. Attach the towing device.

NOTE: Due to the many variables that exist in towing, positioning the lifting and towing device is the sole responsibility of the towing-vehicle operator.

6. Lift the vehicle and secure the safety chains. If extra clearance is needed, remove the bumper extension if equipped.
7. Connect the clearance lights, taillights, and signal lights. Also connect any special towing lights required by local regulations.

Fire in the Cab

The incidence of fire in heavy- and medium-duty trucks is rare. Federal regulations limit the flammability of specified materials used inside the cab, but despite this, most materials will burn. The cab of this vehicle contains urethane foam, which is of concern in this respect.



Urethane foam is flammable! Do not allow any flames, sparks, or other heat sources such as cigarettes or light bulbs to contact urethane foam. Urethane foam in contact with such heat sources could cause a serious, rapid fire, which could result in death, severe burns, or gas poisoning, as well as damage to the vehicle.

In Case of a Cab Fire

As quickly as possible, bring the vehicle to a safe stop, apply the parking brake, turn off the ignition, and get out of the vehicle.

22

Pre- and Post-Trip Checklists

Periodic Inspections and Maintenance, General Information	22.1
Checklists	22.1
Fluids Added	22.2

Pre- and Post-Trip Checklists

Periodic Inspections and Maintenance, General Information

It is the driver's responsibility to perform an inspection, and ensure the complete road-worthiness of a vehicle, before placing it into service. Commercial vehicles may be subject to inspection by authorized inspectors, and an unsafe vehicle can be taken out of service until the driver or owner repairs it.

Use the following checklists to ensure that vehicle components are in good working condition before each trip. Careful inspections eliminate stops later to fix overlooked or forgotten items.

The checklists in this chapter can be copied and kept as a record that the procedures have been completed. For details on how to inspect each item on the checklists, see the corresponding procedure (step number) in [Chapter 23](#).

Checklists

NOTE: Checklists in this chapter correspond with the procedures and steps in [Chapter 23](#), *Pre- and Post-Trip Inspections and Maintenance*. Your vehicle may not be equipped with all components listed below.

Daily Pretrip Inspection Checklists

See the following tables for a list of procedures that should be performed daily, before the first trip. Place a check mark in the complete (**Comp.**) column to indicate a procedure has been performed.

Inspector	Date

Suspension and Slack Adjusters		Comp.
1	Suspension components	
2	Slack adjusters	

Wheels and Tires		Comp.
1	Tire condition	
2	Tire inflation	
3	Rims and wheel components	
4	Wheel bearing oil seals and lubrication levels	
5	Mud Flaps	

Saddle Tank Areas		Comp.
1	Drain air reservoirs (without automatic drain valves)	
2	Fuel tank(s) secure	
3	Frame rails and crossmembers	
4	Visible exhaust components	
5	Air intake system	

Forward Engine Compartment		Comp.
1	Leakage under engine	
2	Engine oil level	
3	Engine coolant level	
4	Windshield washer reservoir level	

Cab		Comp.
1	Reset dash-mounted air intake restriction indicator	
2	Air-pressure warning systems	
3	Air governor cut-in and cut-out pressures	
4	Air pressure build-up time	
5	Air system leakage	
6	Air pressure reserve	
7	Mirrors, windows, windshield	
8	Horn, windshield wipers, windshield washers	
9	Heater and defroster	
10	Interior lights	
11	Exterior lights	
12	Seat belts and tether belts	
13	Fuel level	
14	Mirror adjustment	
15	Service brakes	
16	Backup alarm	

Pre- and Post-Trip Checklists

Weekly Post-trip Inspection Checklist

See the following table for procedures that should be performed weekly, post-trip. Place a check mark in the complete (**Comp.**) column to indicate a procedure has been performed.

Inspector		Date
Air Intake System		Comp.
1	Air intake restriction indicator	
2	Reset air restriction indicator if necessary	
Engine Compartment		Comp.
1	Fuel/water separator	
2	Steering components	
3	Serpentine belts	
4	Power steering fluid level	
5	Visible engine wiring	

Monthly Post-trip Inspection Checklists

See the following tables for procedures that should be performed monthly, post-trip. Place a check mark in the complete (**Comp.**) column to indicate a procedure has been performed.

Inspector		Date
Brake Components		Comp.
1	Brake system components	
2	Brake chambers	
3	Air brake lines	
4	Flex air hoses	
5	Brake linings and brake drums	
6	Brake lining thickness	
Saddle Tank Areas		Comp.
1	Drain air reservoirs (with automatic drain valves)	
2	Batteries	
Engine Compartment		Comp.
1	Hydraulic clutch reservoir	
2	Radiator and heater hoses	

Fluids Added

Use the following table to note any fluids that were added during the inspection and maintenance procedures.

Fluids Added During Inspection	
Fluid	Amount Added
Wheel Bearing Lubricant	
Engine Oil	
Power Steering Fluid	
Engine Coolant	
Windshield Washer Fluid	
Hydraulic Clutch Fluid (DOT 4 brake fluid)	

23

Pre- and Post-Trip Inspections and Maintenance

Daily Pretrip Inspection and Maintenance	23.1
Weekly Post-Trip Inspections and Maintenance	23.7
Monthly Post-Trip Inspections and Maintenance	23.9

Pre- and Post-Trip Inspections and Maintenance

Daily Pretrip Inspection and Maintenance

Complete the following inspection and maintenance procedures to ensure that vehicle components are in good working condition before each trip. A driver who is familiar with the vehicle and drives it regularly can perform the daily inspections, then add the weekly and monthly post-trip inspections as scheduled.

If the driver does not operate the vehicle on a consistent basis, all daily, weekly, and monthly inspection and maintenance procedures should be performed before the trip.

IMPORTANT: The pre- and post-trip checklists, inspections, and maintenance procedures detailed in this chapter are **not all-inclusive**. Refer to other component and body manufacturers' instructions for specific inspection and maintenance instructions, as well as local, state, and federal guidelines.

NOTE: If any system or component does not pass this inspection, it must be corrected before operating the vehicle. Whenever equipment requires adjustment, replacement, and/or repair, see the *Century Class Trucks Workshop Manual* for procedures and specifications.

Suspension and Slack Adjuster Inspection

Walk around the vehicle and visually inspect suspension and slack adjuster components.

1. Inspect the following suspension components for signs of structural damage, cracks, or wear.
 - springs
 - spring hangers
 - shocks
 - suspension arms
 - suspension brackets
 - axle seats
 - bushings
2. Inspect slack adjusters for signs of damage. See [Fig. 23.1](#), [Fig. 23.2](#), or [Fig. 23.3](#).

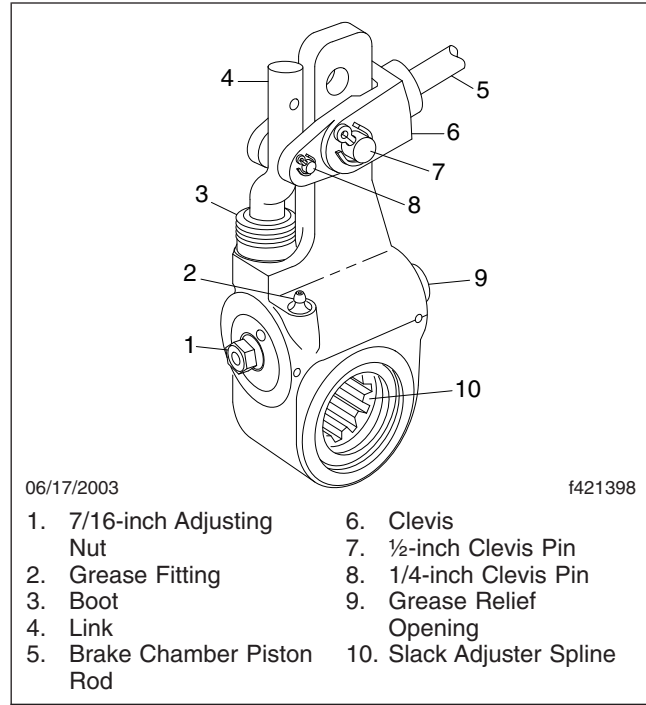

Fig. 23.1, Gunite Automatic Slack Adjuster

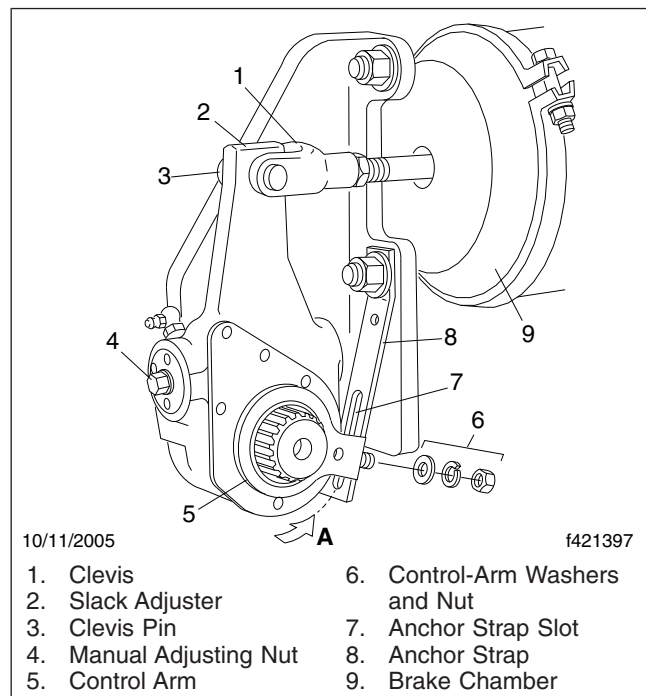

Fig. 23.2, Haldex Automatic Slack Adjuster

Pre- and Post-Trip Inspections and Maintenance

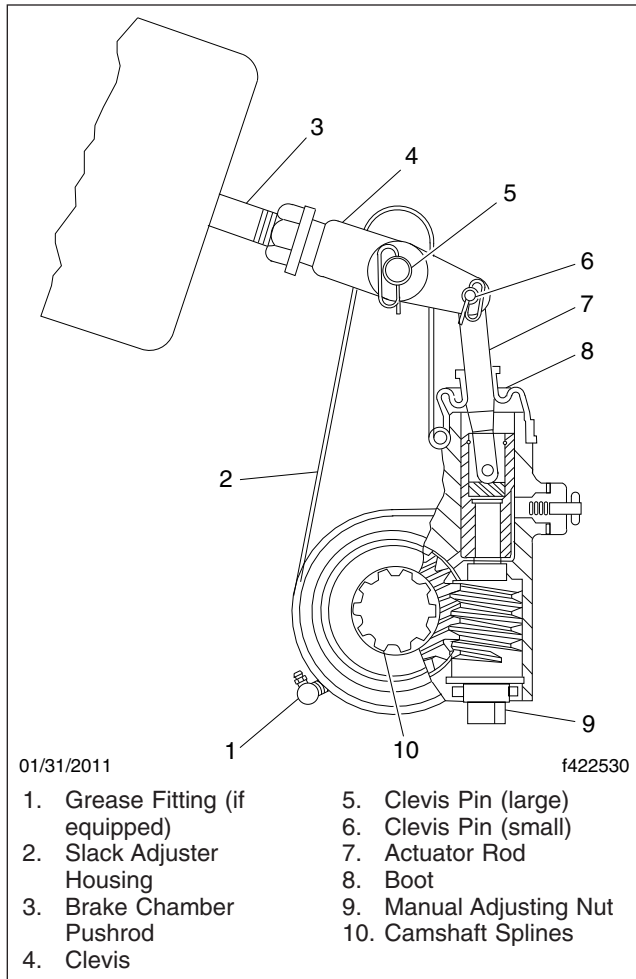

Fig. 23.3, Meritor Automatic Slack Adjuster

- Inspect slack adjuster boots, if equipped, for cuts or tears.
- Inspect anchor straps, if equipped, for damage.
- Look for worn clevis pins on brake chamber pushrods.
- Look for missing or damaged cotter pins on the clevis pins.
- Ensure chamber piston rods are in line with the slack adjusters.

Wheel and Tire Inspection

Walk around the vehicle and visually inspect each wheel and tire assembly.

1. Inspect each tire for the following:
 - valve stem caps on every tire, screwed on finger-tight
 - bulges, cracks, cuts, and penetrations
 - oil contamination (petroleum derivatives will soften the rubber and destroy the tire)
 - tread depth—if tread is less than 4/32 inch (3 mm) on any front tire, or less than 2/32 inch (1.5 mm) on any rear tire, replace the tire
 - debris lodged between dual tire sets
2. Check tire inflation.

For inflation pressures and maximum loads, see the tire manufacturer's guidelines. Inflate the tires to the applicable pressures if needed.

If a tire has been run flat or under-inflated, check the wheel and tire for damage before adding air.

Keep compressed air reservoirs and lines dry during tire inflation. Use well-maintained inline moisture traps and service them regularly.

WARNING

Do not operate the vehicle with underinflated or overinflated tires. Incorrect inflation can stress the tires and make the tires and rims more susceptible to damage, possibly leading to rim or tire failure and loss of vehicle control, resulting in serious personal injury or death.

NOTICE

A weekly pressure loss of 4 psi (28 kPa) or more in a tire may indicate damage. The tire should be inspected and, if necessary, repaired or replaced by a qualified tire service facility.

IMPORTANT: The load and cold inflation pressure must not exceed the rim or wheel manufacturer's recommendations, even though the tire may be approved for a higher load inflation. Consult the rim or wheel manufacturer for the correct tire inflation pressure for the vehicle load.

3. Examine each rim and wheel component.

Pre- and Post-Trip Inspections and Maintenance

- 3.1 Remove all dirt and debris from the assembly. Rust streaks or metal build-up around stud holes, or out-of-round or worn stud holes, may be caused by loose wheel nuts.

⚠ WARNING

Have any worn or damaged wheel components replaced by a qualified person using the wheel manufacturer's instructions and the wheel industry's standard safety precautions and equipment. Otherwise a vehicle or workshop accident could occur, possibly resulting in serious personal injury or death.

- 3.2 Inspect for broken, cracked, badly worn, bent, rusty, or sprung rings and rims.

NOTICE

Use the recommended torque values and follow the proper tightening sequence. Insufficient wheel nut torque can cause wheel shimmy, resulting in wheel damage, stud breakage, and extreme tire tread wear. Excessive wheel nut torque can break studs, damage threads, and crack discs in the stud hole area.

- 3.3 Make sure all wheel nuts are tightened. If tightening is necessary, use the tightening pattern in [Fig. 23.4](#) or [Fig. 23.5](#) to initially tighten the flange nuts to 50 to 100 lbf-ft (68 to 136 N·m). Then tighten the flange nuts to 450 to 500 lbf-ft (610 to 678 N·m).
4. Inspect the outboard side of all wheel hubs and the hub oil seal area on the inboard side of each wheel for signs of oil leakage. If any oil is found on wheel and tire or brake components, remove the vehicle from service until the leak has been fixed.

If needed, fill the hubs to the level indicated on the hub cap. See **Group 35** of the *Century Class Trucks Maintenance Manual* for recommended lubricants.
5. Check that mud flaps are undamaged and hang 10 inches (25.4 cm) or less from the ground.

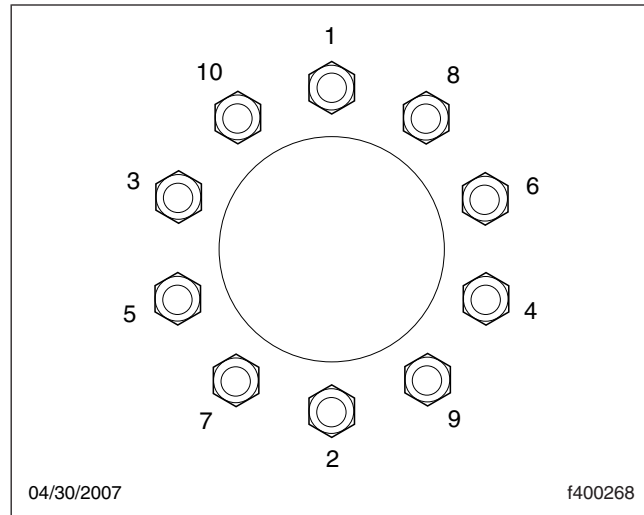

Fig. 23.4, Tightening Pattern, 10-Hole Wheels

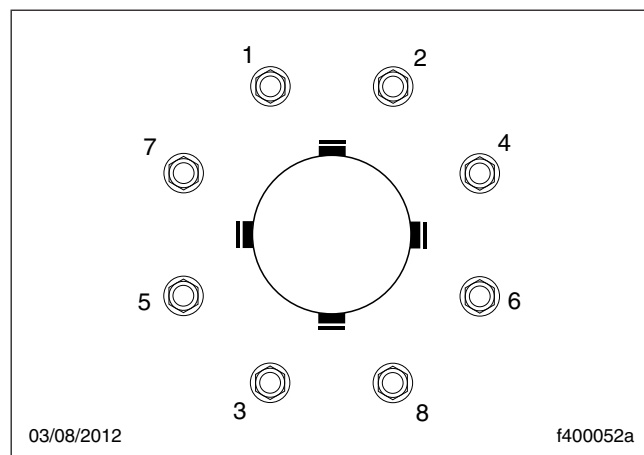

Fig. 23.5, Tightening Pattern, 8-Hole Wheels

Saddle Tank Area Inspections

⚠ WARNING

When draining the air reservoir, do not look into the air jets or direct them toward anyone. Dirt or sludge particles may be in the airstream and could cause injury.

NOTICE

If the water drained from the air reservoirs is cloudy or oily, it may indicate a problem with the compressor. If oil is allowed to contaminate the

Pre- and Post-Trip Inspections and Maintenance

air dryer, it will not remove the water from the air brake system, which could adversely affect braking.

1. Drain the brake system air reservoirs (reservoirs without automatic drain valves only).

WARNING

Never operate the engine with the fuel tank shut-off valves partially closed. This could damage the fuel pump, causing sudden loss of engine power, possibly resulting in serious personal injury due to reduced vehicle control.

2. Ensure fuel tanks are secured to their mounting brackets and that the mounting brackets are secured to the frame.

If equipped with fuel tank shutoff valves, be sure the valves are fully open.

3. Inspect visible frame rails for missing bolts, shiny areas, or rust streaks. Check all visible cross-members for damage or signs of looseness.
4. Inspect visible components of the exhaust system to ensure connections are tight.

Inspect upstream of the aftertreatment device (ATD), if equipped, for cracking or signs of leaks, such as soot trails. Inspect downstream of the ATD for signs of exhaust leaks, such as blistering or warping of nearby components.

NOTICE

Failure to maintain a sealed air intake system could allow the entry of dirt and contaminants into the engine. This could adversely affect engine performance and result in engine damage.

5. Inspect the air intake system for leaks or damage. Ensure the snorkel intake is free of debris, if equipped.

Push the reset button on the air intake restriction indicator located on the air cleaner, if equipped.

Forward Engine Compartment Inspection

Open the grille. See [Chapter 2](#) for instructions.

1. Check the ground underneath the engine for fuel, oil, or coolant leaks.

2. Check the engine oil level.

NOTICE

Operating the engine with the oil level below the minimum fill (or "add") mark or above the maximum fill (or "full") mark could result in engine damage.

- 2.1 Check the oil level with the vehicle parked on a level surface. See [Fig. 23.6](#). See the engine manufacturer's guidelines for engine shutdown time requirements prior to checking the oil level.

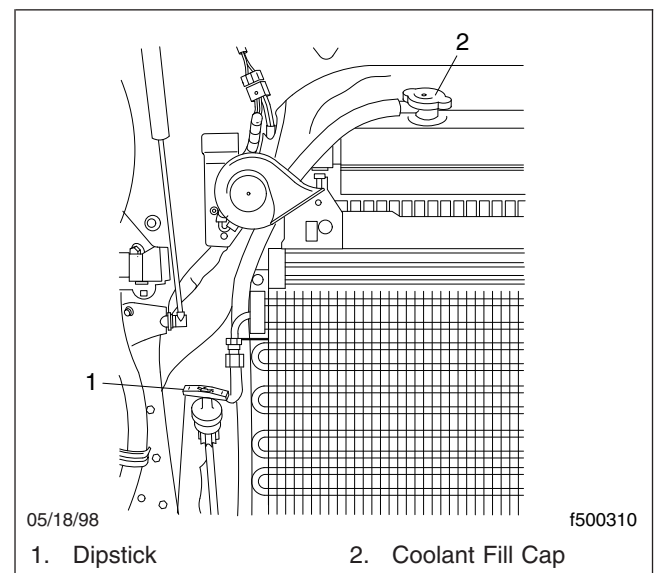

Fig. 23.6, Oil Level Checking

IMPORTANT: On engines that are equipped with an exhaust aftertreatment system (ATS), use engine oil with less than 1% sulfated ash.

- 2.2 If the oil level is at or below the minimum fill (or "add") mark on the dipstick, add enough oil to maintain the level between the minimum and maximum fill marks. See the engine operation manual for recommended lubricants.

NOTICE

Low coolant could result in engine overheating, which could cause engine damage.

Pre- and Post-Trip Inspections and Maintenance

IMPORTANT: The surge tank must be cool to check the coolant level.

3. Check the engine coolant level in the radiator surge tank. See **Fig. 23.6**.

NOTICE

Coolant must be filled to the full line of the surge tank. Low coolant could result in engine overheating, which could cause engine damage.

- 3.1 If the coolant is low, fill the surge tank to the full line with a 50/50 mixture of water and the type of antifreeze currently installed in your vehicle.
- 3.2 If the surge tank was empty, start the engine after refilling and check the level again when the engine is at operating temperature.

WARNING

Washer fluids may be flammable and poisonous. Do not expose washer fluid to an open flame or any burning material, such as a cigarette. Always comply with the washer fluid manufacturer's recommended safety precautions.

4. Check the windshield washer reservoir fluid level. See **Fig. 23.7**.

Cab Inspection

1. Push the reset button on the dash-mounted air intake restriction indicator, if equipped.
2. With the ignition switch in the OFF position, check the air-pressure warning system.
 - 2.1 If not previously drained, drain the air reservoirs using moderate brake applications until pressure in both reservoirs is less than 70 psi (483 kPa).
 - 2.2 Turn the ignition to the ON position. The ICU will complete a full gauge sweep and bulb check, and an audible warning will sound. Ensure the low air pressure lamp remains illuminated and an audible warning continues to sound after the gauge sweep is complete.
3. Check air governor cut-in and cut-out pressures.

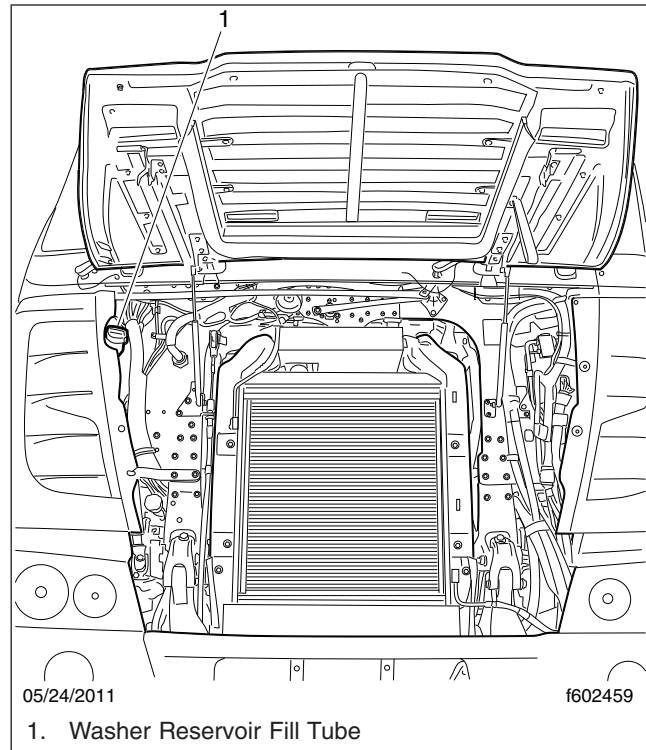

Fig. 23.7, Windshield Washer Reservoir Location (right-hand side location shown)

- 3.1 Start the engine and ensure the low air pressure lamp goes out and the buzzer silences when pressure reaches approximately 70 psi (483 kPa) in both air reservoirs.

The air governor should cut out at approximately 120 psi (827 kPa). For vehicles with an optional dryer reservoir module (DRM), the cut-out pressure is approximately 130 psi (896 kPa).
- 3.2 With the engine idling, apply the brake pedal several times. The air governor should cut in when pressure in the primary air reservoir (top air gauge) reaches approximately 100 psi (690 kPa).
4. Check air pressure build-up time.
 - 4.1 With the air system fully charged, make one full brake application and note the air pressure reading on the primary air gauge.

Pre- and Post-Trip Inspections and Maintenance

- 4.2 Further reduce air pressure using moderate brake applications, then run the engine at governed rpm.
 - 4.3 Note the time that the pressure reaches the previously noted reading on the primary air gauge, then note the time that the air pressure reaches cut-out pressure.
 - 4.4 If it takes longer than 30 seconds to reach cut-out pressure after the primary air gauge passes the previously noted pressure (noted after one full brake application), eliminate any leaks or replace the air compressor before operating the vehicle.
5. Check air leakage in the system.
 - 5.1 With the parking brake applied, the transmission out of gear, and the air system fully charged, release the service brakes and shut down the engine.
 - 5.2 Wait one minute and note the air pressure drop in psi (kPa) per minute from the primary air reservoir.
If the pressure drop exceeds the limits shown in [Table 23.1](#), eliminate any leaks before operating the vehicle.

Maximum Allowable Air Leakage		
Description	Pressure Drop: psi (kPa) Per Minute	
	Released	Applied
Truck or Tractor Only	2 (14)	3 (21)
Truck or Tractor w/Single Trailer	3 (21)	4 (28)
Truck or Tractor w/Two Trailers	5 (34)	6 (41)

Table 23.1, Maximum Allowable Air Leakage

6. Check the air pressure reserve.
With the engine still off, make one full brake application and observe the pressure drop on the primary air gauge. If pressure drops more than 25 psi (172 kPa), eliminate any leaks before operating the vehicle.

WARNING

When cleaning windshields and windows, always stand on the ground or on a secure ladder or platform. Use a long-handled window cleaner. Do not use the cab steps, tires, fenders, fuel tanks,

engine, or under-hood components to access the windshield or windows. Doing so could cause a fall and result in an injury.

7. Inspect the mirrors, window glass, and windshield for cracks or other damage.
8. Ensure that the horn, windshield wipers, and windshield washers are operating properly. These devices must be in good working order for safe vehicle operation.
9. Ensure the heater and defroster are operating properly.
10. Check the operation of all interior lights.
 - 10.1 Turn on the headlights and leave them on. Ensure all equipped gauge bulbs illuminate in the dash message center.
 - 10.2 Ensure all equipped driver control switches illuminate.
 - 10.3 Ensure both turn signal indicator bulbs illuminate in the dash message center when the turn signal switch is activated.
11. Check the operation of all exterior lights. See [Fig. 23.8](#).

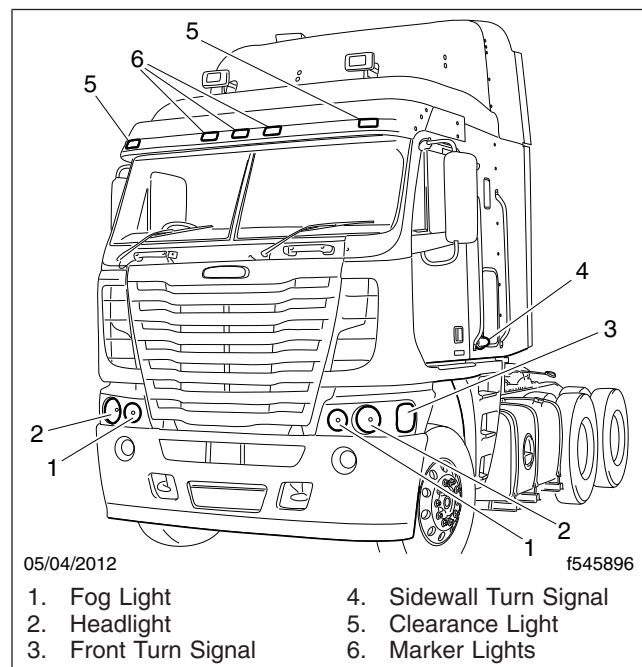

Fig. 23.8, Exterior Lights

Pre- and Post-Trip Inspections and Maintenance

- 11.1 Activate the high-beam headlights and hazard warning lights.
- 11.2 Exit the cab and check that all exterior lights and reflectors are clean and intact.
- 11.3 Check that the brake lights, taillights, headlights, turn signals, marker lights, identification lights, and clearance lights are working properly.

12. Inspect the seat belts and tether belts.

WARNING

Inspect and maintain seat belts. When any part of a seat belt system needs replacement, the entire seat belt must be replaced, both retractor and buckle side. Any time a vehicle is involved in an accident, and the seat belt system was in use, the entire vehicle seat belt system must be replaced before operating the vehicle. Do not attempt to modify the seat belt system; doing so could change the effectiveness of the system. Failure to replace worn or damaged seat belts, or making any modifications to the system, may result in personal injury or death.

- 12.1 Check the web for fraying, cuts, extreme dirt and dust, or for severe fading from exposure to sunlight, especially near the buckle latch plate and in the D-loop guide area.
- 12.2 Check operation of the buckle, latch, web retractor, and upper seat belt mount on the door pillar. Check all visible components for wear or damage.
- 12.3 Check the seat belt and tether belt connection points and tighten any that are loose.

WARNING

Never fill fuel tanks to more than 95 percent of their liquid capacity. This could make them more likely to rupture from impact, possibly causing fire and resulting in serious personal injury or death by burning.

Do not mix gasoline or alcohol with diesel fuel. This mixture could cause an explosion, possibly resulting in serious personal injury or death. Do not fill the fuel tanks in the presence of sparks,

open flames, or intense heat. These could ignite the fuel, possibly causing severe burns.

IMPORTANT: On engines that are equipped with an exhaust ATS, use ultralow-sulfur diesel (ULSD) with 15 ppm sulfur content or less.

13. Check the fuel level in the fuel tank(s). To keep condensation to a minimum, fuel tanks should be filled at the end of each day.
14. Adjust the rearview and down view mirrors as necessary.
15. Test the service brakes.
 - 15.1 With the engine running and air system fully charged, set the parking brake.
 - 15.2 Put the vehicle in the lowest gear and gently attempt to move it forward. The vehicle should not move.

If the vehicle moves, the parking brakes are not operating correctly and must be repaired before the vehicle is operated.
16. Test the backup alarm.
 - 16.1 Release the parking brake and put the transmission in reverse.
 - 16.2 Move the vehicle slightly backward to ensure that the backup alarm is operating correctly.

Weekly Post-Trip Inspections and Maintenance

Air Intake System Inspection

After resetting the air intake restriction indicator during the daily pretrip inspection, check the indicator again with the engine off.

1. Check an indicator with graduations to see if air restriction exceeds the value shown in [Table 23.2](#).

Check a go/no-go indicator without graduations to see if the colored bar shows through the clear window.

Pre- and Post-Trip Inspections and Maintenance

Air Intake Maximum Restriction Values: inH ₂ O (mmH ₂)		
Engine Make	Pre-EPA07 (ADR 80/02) Engines	EPA07 (ADR 80/03) Engines
Cummins	25 (635)	25 (635)
Detroit	20 (255)	22 (560)
Mercedes-Benz	22 (560)	22 (560)

Table 23.2, Air Intake Maximum Restriction Values

- If air restriction exceeds the maximum allowable value, operate the vehicle for one more day, making sure not to run the engine over rated rpm. Refer to the engine operation manual for more information on rated rpm for your engine.

If air restriction exceeds the maximum value again, replace the air cleaner. For instructions, refer to **Group 09** of the *Century Class Trucks Workshop Manual*.

Engine Compartment Inspection

Tilt the cab. See [Chapter 2](#) for instructions.

- Check for water in the fuel/water separator, if equipped.

IMPORTANT: When draining fluid from a fuel/water separator, drain the fluid into an appropriate container and dispose of it properly. Many jurisdictions now issue fines for draining fuel/water separators onto the ground.

- 1.1 Place a suitable container under the fuel/water separator.

NOTE: A hose may be used to direct water into the container. Use a hose with a ½-inch pipe thread on DAVCO models.

IMPORTANT: Water in the fuel/water separator will appear as beads. Drain the fuel/water separator only enough to remove the water. Stop draining fluid when fuel begins to drain out. If the fuel/water separator is drained of fuel, it will be necessary to prime the fuel system before the vehicle can be started again.

- 1.2 If the engine is equipped with a built-in water separator, loosen the drain valve, and allow the water to run out. Close the drain valve, taking care not to overtighten it.
- 1.3 *Alliance/Racor Models:* Turn the drain plug counterclockwise to open it. See [Fig. 23.9](#).

DAVCO Models: Remove the vent cap and open the drain. See [Fig. 23.10](#).

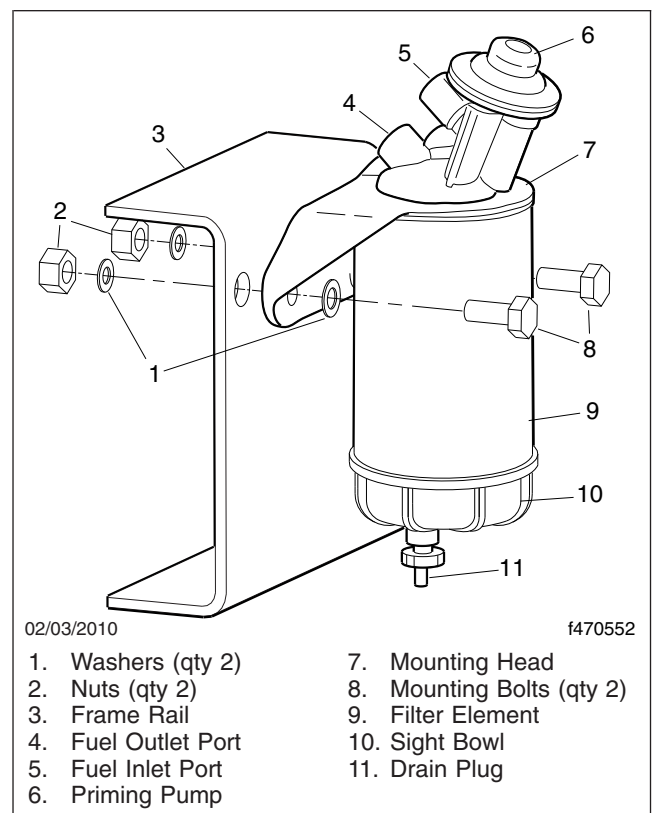

Fig. 23.9, Alliance Fuel/Water Separator Assembly and Installation

- 1.4 Stop draining fluid when fuel begins to drain out.
- Alliance/Racor Models:* Turn the drain plug clockwise to close it.

DAVCO Models: Close the drain valve. Install and hand-tighten the vent cap.

2. Inspect the steering components.

Pre- and Post-Trip Inspections and Maintenance

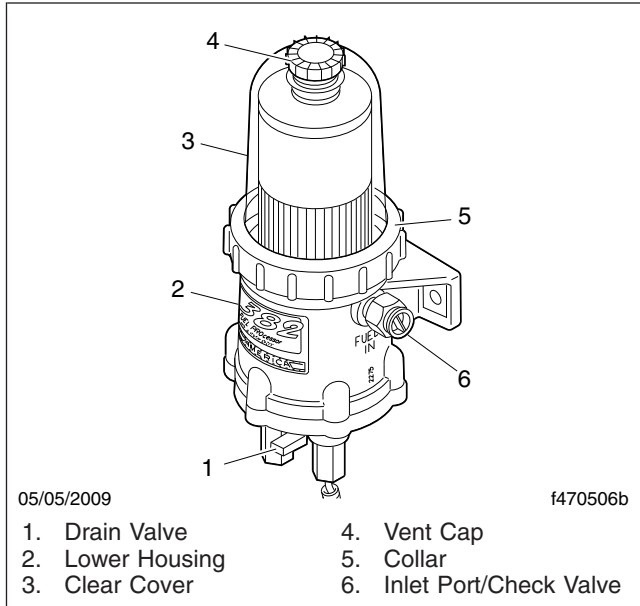

Fig. 23.10, DAVCO Fuel/Water Separator (Fuel Pro 382 shown)

2.1 Inspect tie rods, steering arms, and the drag link for signs of looseness (i.e., shiny spots or rust tracks). See **Fig. 23.11**.

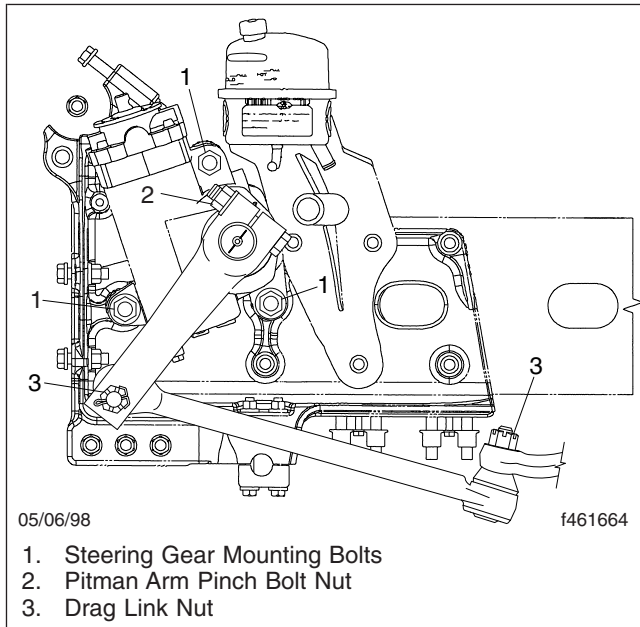

Fig. 23.11, Integral Steering Gear Fasteners

- 2.2 Check the steering gear mounting bolts and pitman arm nut, if equipped, for signs of looseness.
- 2.3 Check the drag link nuts for missing cotter pins.
- 2.4 Inspect the steering intermediate shaft and end yokes for excessive looseness or other damage.

NOTICE

Do not drive with a drive belt that is visibly worn or damaged. If it fails, the lack of coolant flow could rapidly cause damage to engine components.

- 3. Inspect the serpentine drive belts for signs of glazing, frayed edges, breaks, cracks, or oil contamination.
- 4. Check the power steering reservoir fluid level.
The power steering fluid level should be between the MIN COLD mark and the middle mark just above it. If needed, fill the reservoir with automatic transmission fluid that meets Dexron III or TES-389 specifications.
- 5. Inspect visible engine wiring for damage or looseness. Check for loose wiring, chafed insulation, and damaged or loose hold-down clamps.

Monthly Post-Trip Inspections and Maintenance

Brake Component Inspection

Walk around the vehicle and inspect brake system components for visible damage.

- 1. Inspect all visible brake system components for missing fasteners or signs of looseness, such as rust tracks.

NOTICE

If the external breather tube or breather cap is missing or incorrectly installed, road dirt and debris can adversely affect the operation of the brake chamber. Once inside of the chamber, dirt and debris can cause the internal parts of the chamber to deteriorate faster.

Pre- and Post-Trip Inspections and Maintenance

2. Inspect the exterior surfaces of brake chambers for damage. Make sure that breather holes are open and free of debris.

NOTE: Do not route air brake lines on top of anything likely to be stepped on.

3. Inspect air brake lines for dents, swelling, kinks, twisting, abrasion, and damage, especially near moving parts.
4. Inspect flex air lines for deterioration or signs of abrasion.
5. Inspect for cracked, worn, or oil-contaminated brake linings and brake drums (or rotors).
6. Check the thickness of the brake linings. Replace brake linings on all brake assemblies on the axle if any brake linings are worn to less than approximately 1/4 inch (6.4 mm) at the thinnest point.

Saddle Tank Area Inspection



When draining the air reservoir, do not look into the air jets or direct them toward anyone. Dirt or sludge particles may be in the airstream and could cause injury.

NOTICE

If the water drained from the air reservoirs is cloudy or oily, it may indicate a problem with the compressor. If oil is allowed to contaminate the air dryer, it will not remove the water from the air brake system, which could adversely affect braking.

1. Drain the brake system air reservoirs (reservoirs with automatic drain valves only).
2. Inspect the batteries.



Battery posts, terminals, and related accessories contain lead and lead compounds, chemicals known to the State of California to cause cancer and reproductive harm. To prevent possible personal injury, always wash your hands after handling battery parts and related accessories.

- 2.1 Remove the battery box cover and inspect all visible battery cables for loose wiring or damage.
- 2.2 Check that the battery hold-down is secure.

Engine Compartment Inspection

Tilt the cab. See [Chapter 2](#) for instructions.

1. Check the hydraulic clutch reservoir, if equipped. If necessary, add DOT 4 brake fluid.
2. Inspect the radiator and heater hoses, including the clamps and support brackets.
 - 2.1 Inspect the radiator and charge air cooler for damage and accumulated debris. Straighten bent or damaged fins to permit airflow across all areas of the cores.

NOTE: When traveling through areas of high insect concentration, it may be necessary to clean the exterior of the radiator or the charge air cooler core as often as every 200 miles (322 km).

- 2.2 Make sure the radiator inlet and outlet hoses are pliable and are not cracking or ballooning.
- 2.3 Make sure the heater hoses are pliable and are not cracking or ballooning.
- 2.4 Tighten hose clamps as necessary.

IMPORTANT: Do not overtighten hose clamps, as hose life can be adversely affected.

- 2.5 Ensure hose support brackets are securely fastened. Make sure hoses are not located near sources of wear, abrasion, or high heat.

IMPORTANT: When replacing hoses, install service-type knitted or braided yarn-reinforced neoprene hose. Extended-service-life silicone hoses may also be used. See the Alliance Parts Catalog at www.alliancebrandparts.com or contact your Freightliner dealer.

Index

Subject	Page
A	
ABTS Seat	7.5
Armrest Adjustment	7.6
Backrest Adjustment	7.6
Cushion Extension Adjustment	7.5
Isolator	7.5
Lumbar Adjustment	7.6
Seat Height Adjustment	7.6
Seat Tilt Control	7.6
Shoulder Belt Height Control	7.6
Track Adjustment	7.5
Adjustable Steering Column Controls	5.12
Adjusting Headlight Aim	19.1
Air Brake System	12.1
Automatic Slack Adjusters	12.3
Brake System Components	12.1
Brake System General Information	12.1
Brake System Operation	12.1
Air-Suspension Dump Valve	18.1

B	
Back-of-Cab Access	2.7
Accessing Back-of-Cab Area	2.7
Exiting the Back-of-Cab Area	2.8
Battery Access	3.1
Bostrom Seat	7.3
Backrest Recline	7.3
Bottom Cushion Tilt	7.3
Fore-and-Aft Seat Slide	7.3
Height Adjustment	7.4
Isolator	7.4
Lumbar Support	7.4

C	
Cab Access, Fixed Steps	2.1
Left Side Entry	2.1
Left Side Exit	2.2
Right Side Entry	2.3
Right Side Exit	2.3
Cab Access, Mobile Stairs	2.4
Left Side Entry	2.4
Left Side Exit	2.5
Mobile Stair Lock-Up Procedures	2.6
Right Side Entry	2.5
Right Side Exit	2.6

Subject	Page
Cab Amenities	8.1
Center Dash Panel	8.1
Lighting	8.1
Radio and CB	8.1
Storage Areas	8.1
Cab Climate Control Panel	6.1
Air Selection Knob	6.1
Bunk Override Switch	6.2
Fan Control Knob	6.1
Recirculation Switch	6.1
Temperature Control Knob	6.1
Cab Load Disconnect Switch	3.1
Cab Tilt System	2.9
Hydraulic Lockup	2.11
Returning the Cab to Operating Position	2.10
Tilting the Cab	2.9
Care of Chrome Parts	20.1
Care of Exterior Lights	20.2
Care of Fiberglass Parts	20.1
Checking Headlight Aim	19.1
Checklists	22.1
Daily Pretrip Inspection Checklists	22.1
Monthly Post-trip Inspection Checklists	22.2
Weekly Post-trip Inspection Checklist	22.2
Circuit Breaker/Relay Panel	3.1
Climate Controls	5.11
Cab Climate Control	5.11
Sleeper Climate Control	5.11
Clutch	14.4
Clutch General Information	14.4
Clutch Maintenance	14.6
Clutch Operation	14.5
Component Information Label	1.1
Cruise Control	5.7
Cruise at a particular speed	5.8
Disengage cruise control	5.8

D	
Daily Pretrip Inspection and Maintenance	23.1
Cab Inspection	23.5
Forward Engine Compartment Inspection	23.4
Saddle Tank Area Inspections	23.3
Suspension and Slack Adjuster Inspection	23.1
Wheel and Tire Inspection	23.2

Subject	Page	Subject	Page
Dashboard Care	20.1	Creep Mode	15.8
Dash-Mounted Brake Controls	5.8	Engine Overspeed Protection	15.9
Antilock Braking System	5.8	Engine Shutdown	15.7
Engine Brake Switch	5.9	Engine Start Up	15.6
Parking Brake Control Valve	5.9	Hill Start Aid	15.9
Trailer Air Supply Valve	5.9	Load-Based Shifting	15.10
Trailer Brake Lever	5.9	Low (L)	15.8
Differential Lock	16.1	Manual Mode (MAN)	15.7
Differential Lock Operation	16.1	Reverse	15.7
Differential Lock Switches	16.1	Shuttle Shifting	15.9
Door Locks and Handles	2.1	Skip Shifting	15.9
Driver Message Center	4.10	Eaton Fuller® Transmission, Operating Tips	14.1
ICU2M	4.17	Emergency Filter Replacement, DAVCO	21.1
ICU3	4.14	Emergency Kit, Optional	21.1
ICU4M	4.10	Emergency Starting With Jumper Cables	21.2
E			
Eaton Fuller AutoShift Transmission	15.10	Engine Brake	12.5
General Information, AutoShift Transmission	15.10	Engine Brake Operation	12.6
Operation, AutoShift Transmission	15.10	Engine Operation	9.2
Eaton Fuller Splitter and Range-Shift Transmissions	14.1	Cold-Weather Operation	9.3
Eaton Fuller 10-Speed Range-Shift Transmissions	14.4	Engine Break-In	9.2
Eaton Fuller 13-Speed Splitter and Range-Shift Transmissions	14.2	High-Altitude Operation	9.3
Eaton Fuller 18-Speed Splitter and Range-Shift Transmissions	14.3	Normal Operation	9.2
General Information, Range-Shift Transmissions	14.1	Safety and Environmental Considerations	9.2
General Information, Splitter Control	14.1	Engine Protection—Warning and Shutdown	10.1
Eaton Fuller UltraShift DM Transmission	15.1	Engine Shutdown	9.3
General Information, Ultrashift Transmission	15.1	Engine Starting	9.1
Operation, UltraShift Transmission	15.1	Cold-Weather Starting	9.2
Ultrashift Diagnostics	15.5	Starting After Extended Shutdown	9.2
Eaton Fuller UltraShift PLUS Transmission	15.6	Exhaust Aftertreatment System, Optional	11.1
Auto Neutral	15.9	ATS Warning Lamps	11.2
Auto Start Gear Selection and Override	15.9	Maintenance	11.3
Automatic Mode (AUTO)	15.7	Regeneration	11.1
Automatic Traction Control	15.9	EzyRider® Seat	7.4
Clutch Abuse Protection	15.8	Armrest Angle (optional armrests)	7.4
Coasting	15.10	Backrest Recline	7.4
		Bottom Cushion Angle	7.4
		Fore-and-Aft Slide Adjustment	7.4
		Height Adjustment	7.4
		Isolator	7.4
		Lumbar Support	7.5

Index

Subject	Page
F	
Fifth Wheel Coupling	17.1
Coupling, Fontaine or Holland Fifth Wheel	17.1
Coupling, Jost Fifth Wheel	17.3
Fifth Wheel Slide	17.5
Air Slide Operation	17.6
Fifth Wheel Uncoupling	17.4
Air-Actuated Uncoupling	17.4
Manual Uncoupling	17.4
Fifth Wheels, General Information	17.1
Air-Suspension Dump Valve	17.1
Fifth Wheel Lubrication	17.1
Fire Extinguisher	21.1
Fire in the Cab	21.6
In Case of a Cab Fire	21.6
Fluids Added	22.2
Freightliner High-Back Seat	7.2
Backrest Tilt	7.2
Bottom Cushion Extension	7.3
Fore/Aft Isolator	7.3
Fore/Aft Seat Slide	7.3
Front Cushion Height	7.3
Heater	7.3
Height Adjustment	7.2
Lumbar Support	7.2
Rear Cushion Height	7.3
Shock Absorber	7.3
Freightliner SmartShift Shift Control	15.1
H	
Hazard Warning Lights	21.1
Holland Trailer Couplings	18.1
General Information	18.1
Trailer Hookup	18.1
Trailer Release	18.1
Horn Controls	5.4
Air Horn	5.4
Electric Horn	5.4
I	
Ignition Switch and Key	5.1
Instrumentation Control Units	4.1
Audible Alerts	4.2
Ignition Sequence	4.1
Instruments	4.7
Air Intake Restriction Gauge	4.7

Subject	Page
Application Air Pressure Gauge	4.7
Coolant Temperature Gauge	4.8
Drive Axle Oil Temperature Gauges	4.8
Engine Oil Pressure Gauge	4.8
Engine Oil Temperature Gauge	4.8
Fuel Gauge	4.9
Primary and Secondary Air Pressure Gauges	4.9
Speedometer	4.9
Tachometer	4.9
Transmission Fluid Temperature Gauge	4.9
Turbocharger Boost Pressure Gauge	4.9
Voltmeter	4.9
Interaxle Lock	16.2
Interaxle Lock Operation	16.2
Interaxle Lock Switch	16.2
L	
Lighting Controls	5.2
Exterior Lighting Controls	5.2
Interior Lighting Controls	5.3
Low Voltage Disconnect Feature	3.1
M	
Meritor WABCO® Antilock Braking System	12.3
Automatic Traction Control	12.5
Trailer ABS Compatibility	12.4
Mirrors	8.1
Monthly Post-Trip Inspections and Maintenance	23.9
Brake Component Inspection	23.9
Engine Compartment Inspection	23.10
Saddle Tank Area Inspection	23.10
N	
National Seat	7.5
Backrest Recline	7.5
Bottom Cushion Extension	7.5
Fore-and-Aft Seat Slide	7.5
Height Adjustment	7.5
Isolator	7.5
Lumbar Support	7.5

Subject	Page	Subject	Page
Rear Cushion Adjustment	7.5	Suspension/Trailer Connection	
O		Controls	5.10
Opening the Grille	2.8	Air Suspension Dump	
Overhead Instrument Panel	4.19	Control Switch	5.10
P		Fifth Wheel Slide Control	
Periodic Inspections and		Switch	5.10
Maintenance, General		Trailer Auxiliary Switch	5.11
Information	22.1	T	
Power Takeoff (PTO) Governor	10.2	Towing	21.3
Powertrain Controls	5.5	Front Towing Hookup	21.4
Aftertreatment System		Rear Towing Hookup	21.5
Regen Switches	5.5	V	
Axle Switches	5.6	Velour Upholstery Cleaning	20.2
Engine Fan Switch	5.6	Chewing Gum or Wax	20.2
Hill Start Aid Override Switch	5.6	Grease and Oil-Based Stains	20.2
PTO Switch	5.7	Mildew	20.2
Transmission Controls	5.7	Sugar and Water-Based	
Preliminary Checks	19.1	Stains	20.2
Premier Trailer Couplings	18.2	Vinyl Upholstery Cleaning	20.1
General Information	18.2	Ball Point Ink	20.2
Trailer Hookup	18.2	Chewing Gum	20.1
Trailer Release	18.2	Miscellaneous	20.2
S		Nail Polish and Nail Polish	
Seat Belts and Tether Belts	7.6	Remover	20.2
Seat Belt Inspection	7.7	Ordinary Dirt	20.1
Seat Belt Operation	7.7	Paint, Shoe Heel Marks	20.1
Seat Controls	5.12	Shoe Polish	20.2
Seats, General Information	7.1	Sulfide Stains	20.2
Sleeper Amenities	8.2	Tars, Asphalts, and Creosote	20.1
Baggage Compartment		W	
Doors	8.2	Warning and Indicator Lights	4.3
Bunk Latches	8.2	Engine Protection System	4.3
Lighting	8.2	Weekly Post-Trip Inspections	
Power Outlets	8.2	and Maintenance	23.7
Vents	8.2	Air Intake System Inspection	23.7
Sleeper Climate Control Panel	6.2	Engine Compartment	
Fan Control Knob	6.2	Inspection	23.8
Temperature Control Knob	6.3	Windows	8.1
Sleeper Compartment		Windshield Wiper/Washer	
Restraints	7.9	Controls	5.10
Bunk Restraint Adjustment	7.9		
Bunk Restraint Operation	7.9		
Steering System General			
Information	13.1		
Steering Wheel Air Bag	7.10		
Inspection and Service	7.10		
Operation	7.10		